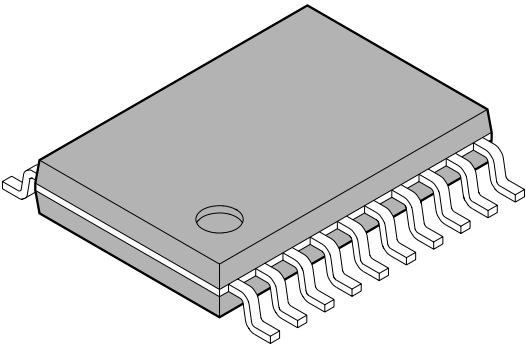

FPT-20P-M04

EIAJ code : SSOP020-P-0225-2

<p>20-pin plastic SSOP</p>  <p>(FPT-20P-M04)</p>	Lead pitch	0.65 mm	
	Lead shape	Gullwing	
	Sealing method	Plastic mold	
	Mounting height	1.20 mmMAX	

20-pin plastic SSOP  
(FPT-20P-M04)

\* : These dimensions do not include resin protrusion.

