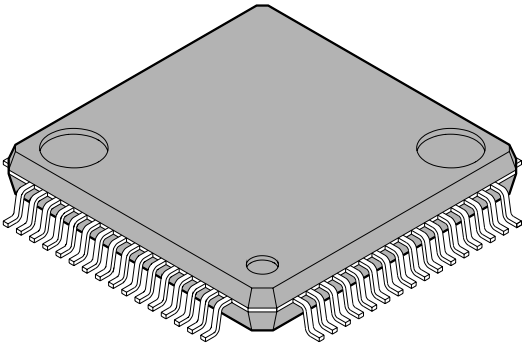

FPT-64P-M03

EIAJ code : *P-LQFP-0064-1010-0.50

<p>64-pin plastic LQFP</p>  <p>(FPT-64P-M03)</p>	Lead pitch	0.50 mm
	Package width × package length	10.0 × 10.0 mm
	Lead shape	Gullwing
	Sealing method	Plastic mold
	Mounting height	1.70 mm MAX
	Weight	0.32 g

64-pin plastic LQFP
(FPT-64P-M03)

*Pins width and pins thickness include plating thickness.

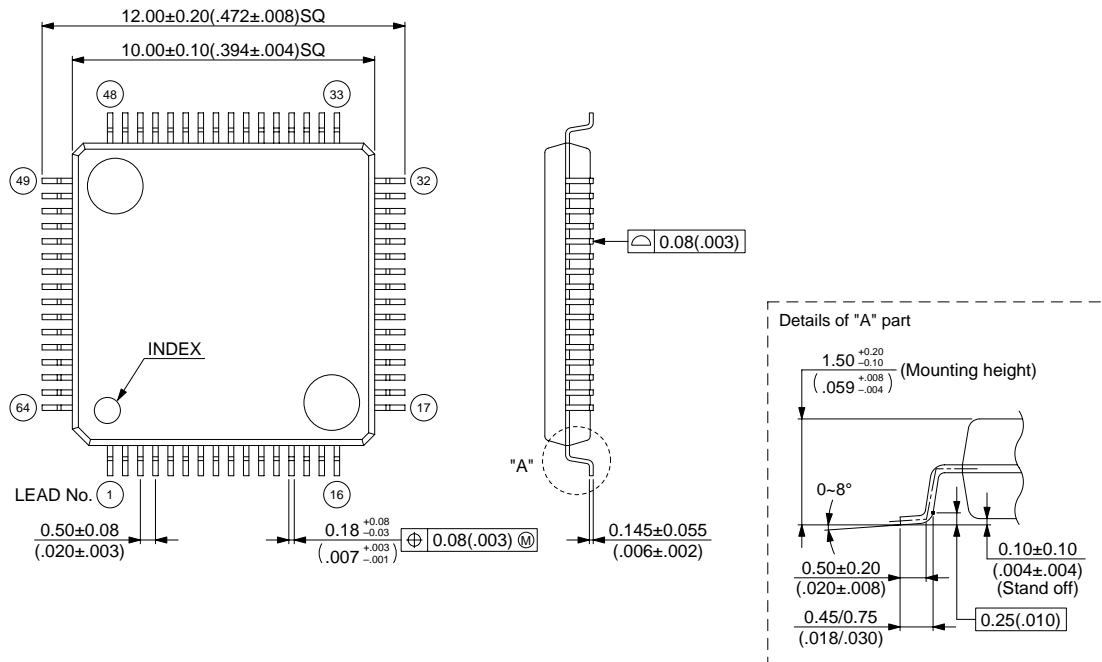

© 1998 FUJITSU LIMITED F64009S-3C-6

Dimensions in mm (inches).

The contents of this document are subject to change without notice. Customers are advised to consult with FUJITSU sales representatives before ordering. FUJITSU is unable to assume responsibility for infringement of any patent rights or other rights of third parties arising from the use of the information or package dimensions in this document.