

SHRINK SMALL OUTLINE L-LEADED PACKAGE 30 PIN PLASTIC

FPT-30P-M02

<p>30-pin plastic SSOP</p>  <p>(FPT-30P-M02)</p>	Lead pitch	0.65mm	
	Lead shape	Gullwing	
	Sealing method	Plastic mold	

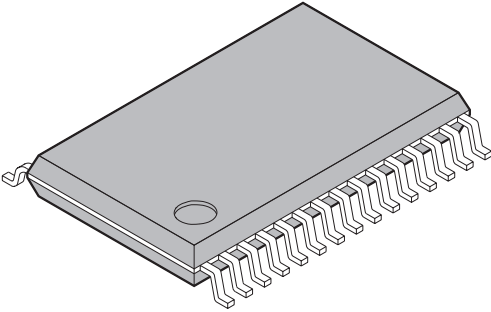