

PGA-208C-A04

EIAJ code : HPGA208-C-S17D-1

<p>208-pin ceramic PGA</p>  <p>(PGA-208C-A04)</p>	Lead pitch	100 mil
	Pin matrix	17
	Sealing method	Metal seal

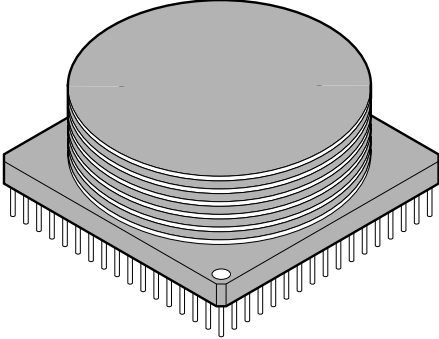