

1:6 PCI Clock Generator/ Fanout Buffer

The MPC905 is a six output clock generation device targeted to provide the clocks required in a 3.3V or 5.0V PCI environment. The device operates from a 3.3V supply and can interface to either a TTL input or an external crystal. The inputs to the device can be driven with 5.0V when the V_{CC} is at 3.3V. The outputs of the MPC905 meet all of the specifications of the PCI standard.

- Six Low Skew Outputs
- Synchronous Output Enables for Power Management
- Low Voltage Operation
- XTAL Oscillator Interface
- 16-Lead SOIC Package
- 5.0V Tolerant Enable Inputs

The MPC905 device is targeted for PCI bus or processor bus environments with up to 12 clock loads. Each of the six outputs on the MPC905 can drive two series terminated 50Ω transmission lines. This capability effectively makes the MPC905 a 1:12 fanout buffer.

The MPC905 offers two synchronous enable inputs to allow users flexibility in developing power management features for their designs. Both enable signals are active HIGH inputs. A logic '0' on the Enable1 will pull outputs 0 to 4 into the logic '0' state. A logic '1' on the Enable1 input will result in outputs 0 to 4 to be toggling. A logic '0' on Enable2 will cause output BLK5 to a logic '0' state, whereas a logic '1' on Enable2 will cause output BLK5 to toggle. The oscillator remains on.

The Enable2 input can be used to disable any high power device for system power savings during periods of inactivity. Both enable inputs are synchronized internal to the chip so that the output disabling will happen only when the outputs are already LOW. This feature guarantees no runt pulses will be generated during enabling and disabling.

MPC905

1:6 PCI CLOCK GENERATOR/ FANOUT BUFFER

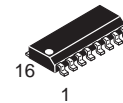

D SUFFIX
PLASTIC SOIC PACKAGE
CASE 751B-05

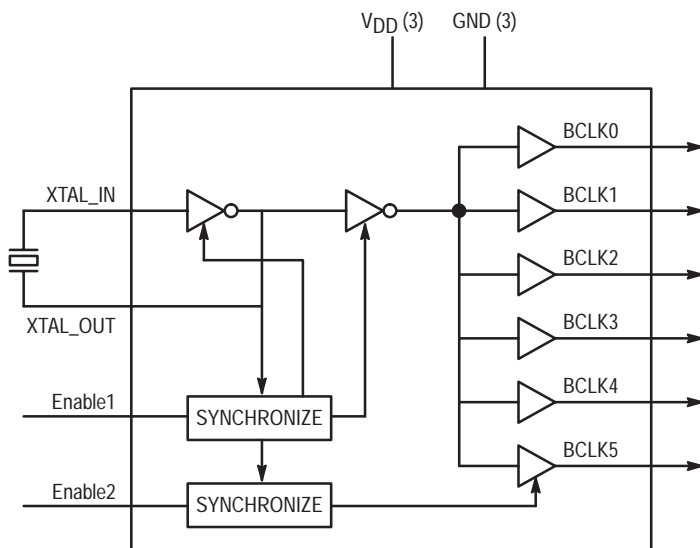

Pinout: 16-Lead Plastic Package (Top View)

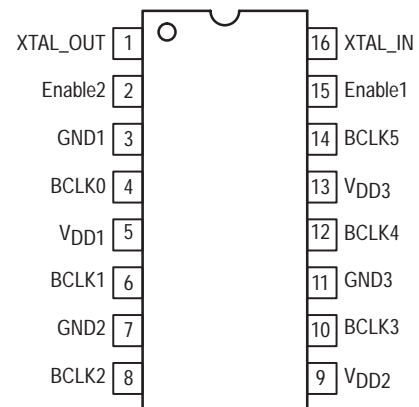

FUNCTION TABLE

ENABLE1	ENABLE2	Outputs 0 to 4	Output 5	OSC (On/Off)
0	0	Low	Low	ON
0	1	Low	Toggling	ON
1	0	Toggling	Low	ON
1	1	Toggling	Toggling	ON

ABSOLUTE MAXIMUM RATINGS*

Symbol	Parameter	Min	Max	Unit
V _{DD}	Supply Voltage	-0.5	4.6	V
V _{IN}	Input Voltage	-0.5	V _{CC} + 0.5	V
T _{oper}	Operating Temperature Range	0	+70	°C
T _{stg}	Storage Temperature Range	-65	+150	°C
T _{sol}	Soldering Temperature Range (10 Sec)		+260	°C
T _j	Junction Temperature Range		+125	°C
ESD	Static Discharge Voltage	1500		V
I _{Latch}	Latch Up Current	50		mA

* Absolute Maximum Ratings are those values beyond which damage to the device may occur. Functional operation should be restricted to the Recommended Operating Conditions.

RECOMMENDED OPERATING CONDITIONS

Symbol	Parameter	Min	Max	Unit
T _A	Ambient Temperature Range	0	70	°C
V _{CC}	Positive Supply Voltage (Functional Range)	3.0	3.6	V
t _{DCin}	T _{high} (at XTAL_IN Input) T _{low} (at XTAL_IN Input)	0.44T ¹ 0.44T ¹	0.56T ¹ 0.56T ¹	T = Period

1. When using External Source for reference, requirement to meet PCI clock duty cycle requirement on the output.

DC CHARACTERISTICS (T_A = 0–70°C; V_{DD} = 3.3V ±0.3V)

Symbol	Characteristic	Min	Typ	Max	Unit	Condition
V _{IH}	High Level Input Voltage	2.0		5.5 ²	V	
V _{IL}	Low Level Input Voltage			0.8	V	
V _{OH}	High Level Output Voltage	2.4			V	I _{OH} = -36mA ¹
V _{OL}	Low Level Output Voltage			0.4	V	I _{OL} = 36mA ¹
I _{IH}	Input High Current			2.5 ²	μA	
I _{IL}	Input Low Current			2.5	μA	
I _{CC}	Power Supply Current		DC 20 33MHz 37 66MHz 78	45 95	μA mA mA	
C _{IN}	Input Capacitance		XTAL_IN Others	9.0 4.5	pF	

1. The MPC905 can drive 50Ω transmission lines on the incident edge. Each output drives one 50Ω parallel terminated transmission line to V_{TT} = V_{CC}/2. Alternately, the device drives up to two 50Ω series terminated transmission lines per output.
2. XTAL_IN input will sink up to 10mA when driven to 5.5V. There are no reliability concerns associated with the condition. Note that the Enable1 input must be a logic HIGH. Do not take the Enable1 input to a logic LOW with >V_{CC} volts on the XTAL_IN input.

AC CHARACTERISTICS ($T_A = 0-70^{\circ}\text{C}$; $V_{DD} = 3.3\text{V} \pm 0.3\text{V}$)

Symbol	Characteristic	Min	Typ	Max	Unit	Condition
F_{max}	Maximum Operating Frequency Using External Crystal Using External Clock Source	– DC		50 100	MHz	
t_{pw}	Output Pulse Width HIGH (Above 2.0V) LOW (Below 0.8V) HIGH (Above 2.0V) LOW (Below 0.8V)	$0.40T^1$ $0.40T^1$ $0.45T^2$ $0.45T^2$		$0.60T^1$ $0.60T^1$ $0.55T^2$ $0.55T^2$		T = Periods
t_{per}	Output Period	T – 400ps				T = Desired Period
t_{os}	Output-to-Output Skew Rising Edges Falling Edges			400 500	ps	
t_r, t_f	Rise/Fall Times (Slew Rate)	1		4	V/ns	Series Terminated Transmission Lines
t_{EN}	Enable Time Enable1 Enable2			5 4	ms Cycles	
t_{DIS}	Disable Time Enable1 Enable2			4 4	Cycles	
A_{osc}	XTAL_IN to XTAL_OUT Oscillator Gain	6			db	
Phase	Loop Phase Shift Modulo $360^{\circ} +$	30			Degrees	

- Assuming input duty cycle specs from Recommended Operating Conditions table are met.
- Assuming external crystal or 50% duty cycle external reference is used.

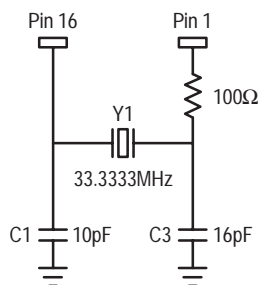

Figure 1. Crystal Oscillator Interface
(Fundamental)

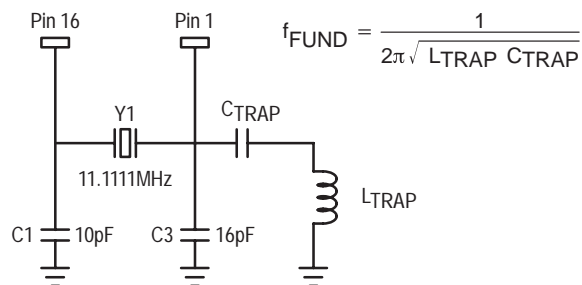

Figure 2. Crystal Oscillator Interface
(3rd Overtone)

Table 1. Crystal Specifications

Parameter	Value
Crystal Cut	Fundamental AT Cut
Resonance	Parallel Resonance*
Frequency Tolerance	$\pm 75\text{ppm}$ at 25°C
Frequency/Temperature Stability	$\pm 150\text{ppm}$ 0 to 70°C
Operating Range	0 to 70°C
Shunt Capacitance	5–7pF
Equivalent Series Resistance (ESR)	50 to 80Ω
Correlation Drive Level	$100\mu\text{W}$
Aging	5ppm/Yr (First 3 Years)

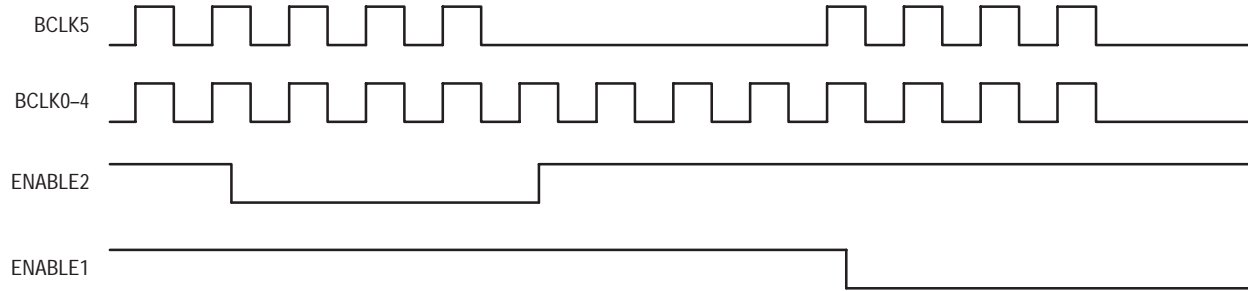

Figure 3. Enable Timing Diagram

APPLICATIONS INFORMATION

Driving Transmission Lines

The MPC905 clock driver was designed to drive high speed signals in a terminated transmission line environment. To provide the optimum flexibility to the user the output drivers were designed to exhibit the lowest impedance possible. With an output impedance of approximately 10Ω the drivers can drive either parallel or series terminated transmission lines. For more information on transmission lines the reader is referred to application note AN1091 in the Timing Solutions brochure (BR1333/D).

In most high performance clock networks point-to-point distribution of signals is the method of choice. In a point-to-point scheme either series terminated or parallel terminated transmission lines can be used. The parallel technique terminates the signal at the end of the line with a 50Ω resistance to VCC/2. This technique draws a fairly high level of DC current and thus only a single terminated line can be driven by each output of the MPC905 clock driver. For the series terminated case however there is no DC current draw, thus the outputs can drive multiple series terminated lines. Figure 4 illustrates an output driving a single series terminated line vs two series terminated lines in parallel. When taken to its extreme the fanout of the MPC905 clock driver is effectively doubled due to its capability to drive multiple lines.

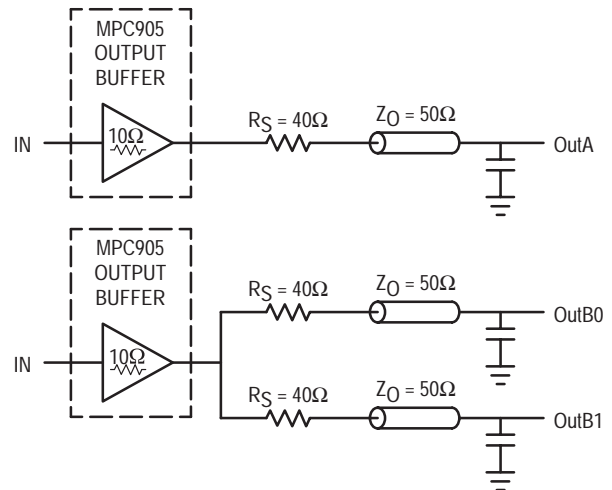

Figure 4. Single versus Dual Transmission Lines

The waveform plots of Figure 5 show the simulation results of an output driving a single line vs two lines. In both cases the drive capability of the MPC905 output buffers is more than sufficient to drive 50Ω transmission lines on the incident edge. Note from the delay measurements in the simulations a delta of only 43ps exists between the two differently loaded outputs. The output waveform in Figure 5

shows a step in the waveform, this step is caused by the impedance mismatch seen looking into the driver. The parallel combination of the 40Ω series resistor plus the output impedance does not match the parallel combination of the line impedances. The voltage wave launched down the two lines will equal:

$$V_L = V_S \left(\frac{Z_0}{R_S + R_o + Z_0} \right) = 3.0 \left(\frac{25}{55} \right) = 1.36V$$

At the load end the voltage will double, due to the near unity reflection coefficient, to 2.73V. It will then increment towards the quiescent 3.0V in steps separated by one round trip delay (in this case 4.0ns).

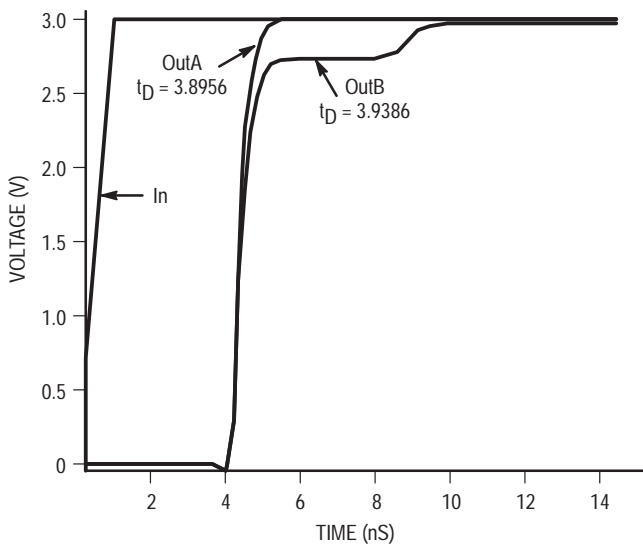

Figure 5. Single versus Dual Waveforms

Since this step is well above the threshold region it will not cause any false clock triggering, however designers may be uncomfortable with unwanted reflections on the line. To better match the impedances when driving multiple lines the situation in Figure 6 should be used. In this case the series terminating resistors are reduced such that when the parallel combination is added to the output buffer impedance the line impedance is perfectly matched.

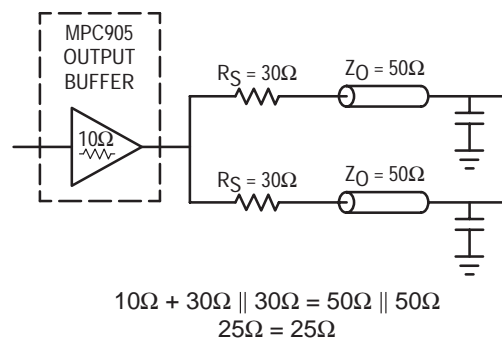
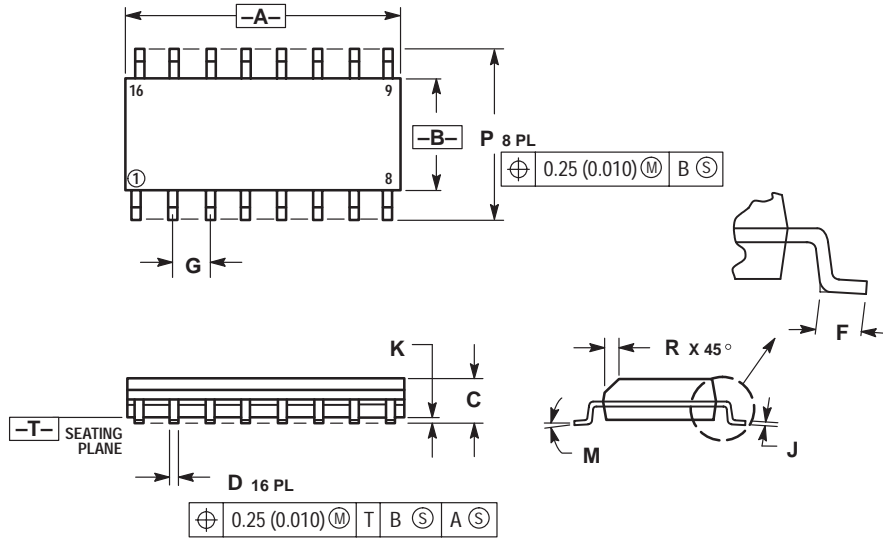

Figure 6. Optimized Dual Line Termination

SPICE level output buffer models are available for engineers who want to simulate their specific interconnect schemes. In addition IV characteristics are in the process of being generated to support the other board level simulators in general use.

OUTLINE DIMENSIONS

D SUFFIX
 PLASTIC SOIC PACKAGE
 CASE 751B-05
 ISSUE J



- NOTES:
1. DIMENSIONING AND TOLERANCING PER ANSI Y14.5M, 1982.
 2. CONTROLLING DIMENSION: MILLIMETER.
 3. DIMENSIONS A AND B DO NOT INCLUDE MOLD PROTRUSION.
 4. MAXIMUM MOLD PROTRUSION 0.15 (0.006) PER SIDE.
 5. DIMENSION D DOES NOT INCLUDE DAMBAR PROTRUSION. ALLOWABLE DAMBAR PROTRUSION SHALL BE 0.127 (0.005) TOTAL IN EXCESS OF THE D DIMENSION AT MAXIMUM MATERIAL CONDITION.

DIM	MILLIMETERS		INCHES	
	MIN	MAX	MIN	MAX
A	9.80	10.00	0.386	0.393
B	3.80	4.00	0.150	0.157
C	1.35	1.75	0.054	0.068
D	0.35	0.49	0.014	0.019
F	0.40	1.25	0.016	0.049
G	1.27 BSC		0.050 BSC	
J	0.19	0.25	0.008	0.009
K	0.10	0.25	0.004	0.009
M	0°	7°	0°	7°
P	5.80	6.20	0.229	0.244
R	0.25	0.50	0.010	0.019

NOTES

Motorola reserves the right to make changes without further notice to any products herein. Motorola makes no warranty, representation or guarantee regarding the suitability of its products for any particular purpose, nor does Motorola assume any liability arising out of the application or use of any product or circuit, and specifically disclaims any and all liability, including without limitation consequential or incidental damages. "Typical" parameters which may be provided in Motorola data sheets and/or specifications can and do vary in different applications and actual performance may vary over time. All operating parameters, including "Typicals" must be validated for each customer application by customer's technical experts. Motorola does not convey any license under its patent rights nor the rights of others. Motorola products are not designed, intended, or authorized for use as components in systems intended for surgical implant into the body, or other applications intended to support or sustain life, or for any other application in which the failure of the Motorola product could create a situation where personal injury or death may occur. Should Buyer purchase or use Motorola products for any such unintended or unauthorized application, Buyer shall indemnify and hold Motorola and its officers, employees, subsidiaries, affiliates, and distributors harmless against all claims, costs, damages, and expenses, and reasonable attorney fees arising out of, directly or indirectly, any claim of personal injury or death associated with such unintended or unauthorized use, even if such claim alleges that Motorola was negligent regarding the design or manufacture of the part. Motorola and  are registered trademarks of Motorola, Inc. Motorola, Inc. is an Equal Opportunity/Affirmative Action Employer.

How to reach us:

USA/EUROPE/Locations Not Listed: Motorola Literature Distribution;
P.O. Box 5405, Denver, Colorado 80217. 1-303-675-2140 or 1-800-441-2447

JAPAN: Motorola Japan Ltd.; SPS, Technical Information Center, 3-20-1,
Minami-Azabu, Minato-ku, Tokyo 106-8573 Japan. 81-3-3440-3569

Technical Information Center: 1-800-521-6274

ASIA/PACIFIC: Motorola Semiconductors H.K. Ltd.; Silicon Harbour Centre,
2, Dai King Street, Tai Po Industrial Estate, Tai Po, N.T., Hong Kong.
852-26668334

HOME PAGE: <http://www.motorola.com/semiconductors/>

**MOTOROLA****MPC905/D**