

# **$\pm 2g$ Acceleration Sensing Module Based on a $\pm 40g$ Integrated Accelerometer**

by: Arnaud Delpoux  
Application Engineer, Toulouse, France  
and  
Brandon Loggins  
Application Engineer, Phoenix, USA

## **INTRODUCTION**

Micromachined accelerometers, with built-in signal conditioning and calibration are widely used in automotive safety devices such as airbag modules. Automotive applications for accelerometers also include comfort features such as active suspension. For such an application, a  $\pm 2g$  accelerometer is required. But most accelerometers

offered today that are able to provide sufficient sensitivity are expensive and/or unavailable in production volumes. With the circuitry described herein, the accelerometer can be used for sensing acceleration in the range of  $\pm 2g$ , with performance in line with the technical requirements of this application.

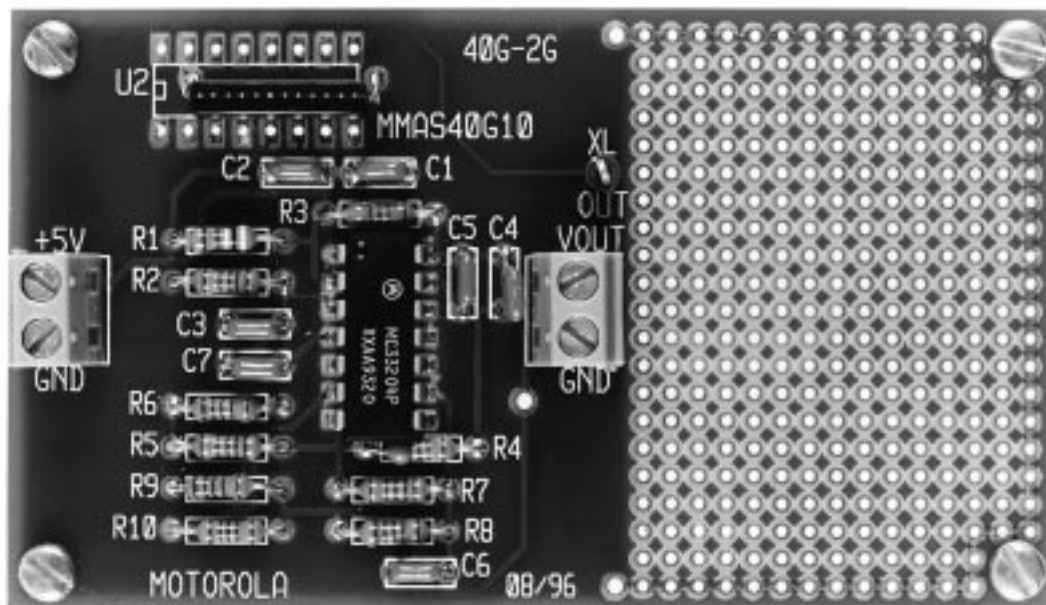

Figure 1. 40G-2G  $\pm 2g$  Sensing Module Evaluation Board

EVALUATION BOARD DESCRIPTION

The information required to use evaluation board “40G–2G” follows and a discussion of the design appears in the Design Considerations section.

Function

The evaluation board shown in Figure 1, when supplied with an accelerometer, provides a  $\pm 2g$  full scale acceleration measurement.

The output is an analog signal. It nominally supplies 2.1 volts at zero g and has a sensitivity of 1000 mV/g. It is easily interfaced with a microcontroller’s A/D input.

A through-hole area is provided on the PCB for the designer to add other circuitry as needed.

Electrical Characteristics

The following electrical characteristics are included as a guide to operation.

Characteristics	Symbol	Min	Typ	Max	Units
Supply Voltage	$V_{CC}$	4.75	5.0	5.25	Volts
Supply Current	$I_O$	—	7.0	—	mA
Acceleration Range	G	-2.0	—	+2.0	g
Zero G Output	$V_{Off}$	2.0	2.1	2.2	Volts
Sensitivity	$\Delta V/\Delta G$	850	1000	1150	mV/g
Low Cutoff Frequency	—	0.8	0.9	1.0	Hz
High Cutoff Frequency	—	4.0	5.0	6.0	Hz
Operating Temperature	$T_a$	-40	—	+85	$^{\circ}C$

Table 1. Electrical Characteristics

Frequency Response

Below is the simulated typical output frequency response using the devices listed in the parts list below. The system provides a gain of 25 over a 5 Hz bandwidth.

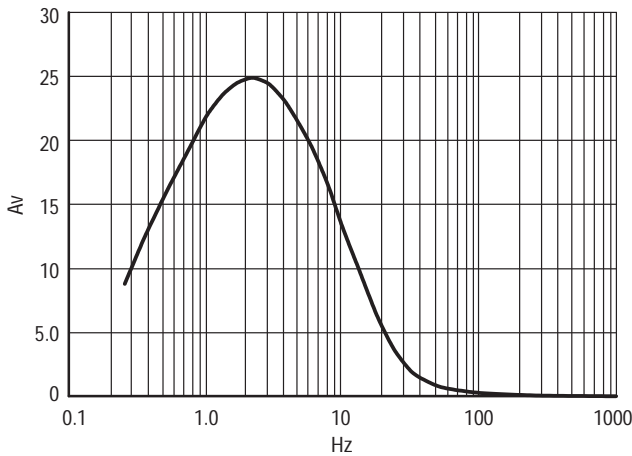

Figure 2.  $\pm 2g$  Biquad Filter with Additional Gain Stage Frequency Response

Evaluation Board Content

Board contents are described in the parts list shown in Table 2. A schematic and silk screen plot are shown in Figures 4 and 5.

Designator	Qty.	Description	Value/Part Number
R1	1	1/4 Watt Resistor	90.9 K
R2, R8	2	1/4 Watt Resistor	162 K
R5, R6, R7, R9, R10	5	1/4 Watt Resistor	11 K
R3, R4	2	1/4 Watt Resistor	432 K
C1–C6	6	Ceramic Capacitor	0.1 $\mu F$
U1	1	Quad Rail-to-Rail Op Amp	MC33204P
U2	1	40g Accelerometer	PMMA2000 Series

Table 2. Parts List

DESIGN CONSIDERATIONS

Using a 40g accelerometer to measure  $\pm 2g$  of acceleration can be tricky. Motorola’s accelerometer provides a wide bandwidth of 400 Hz for acceleration sensing. In many low g applications, such as active suspension, the bandwidth requirements are considerably lower. Limiting the bandwidth of the accelerometer can reduce noise. After reducing the bandwidth, gain can be applied to provide higher sensitivity for low g acceleration measurements.

The design challenge is how to bandpass filter the accelerometer’s output with gain using a few low cost components. To accommodate the accelerometer’s wide dynamic range, since the supply voltage is limited to 5 volts, it is necessary to use rail to rail operational amplifiers, such as Motorola’s MC33204P.

In this design, the output signal passes through a biquad filter stage, then through an additional low-pass gain stage to provide  $\pm 2g$  sensing capability. The biquad filter, shown in Figure 3, with some gain, is a good choice for bandpass filtering the accelerometer output when a high quotient factor, Q, is desired. The gain is set by  $R_g$  and  $R_b$  with the high cutoff frequency being set by  $R_b$  and  $C_1$ . The low cutoff frequency is set by  $R_f$  and  $C_2$ .

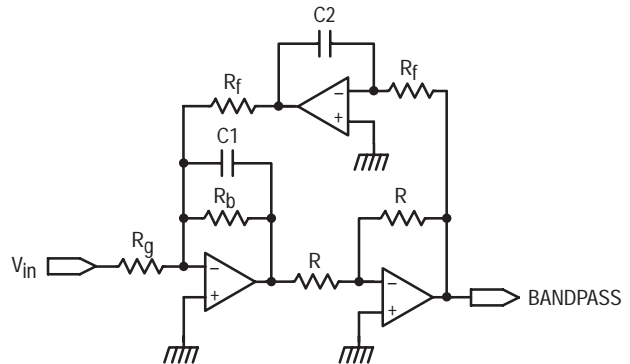

Figure 3. Biquad Active Filter



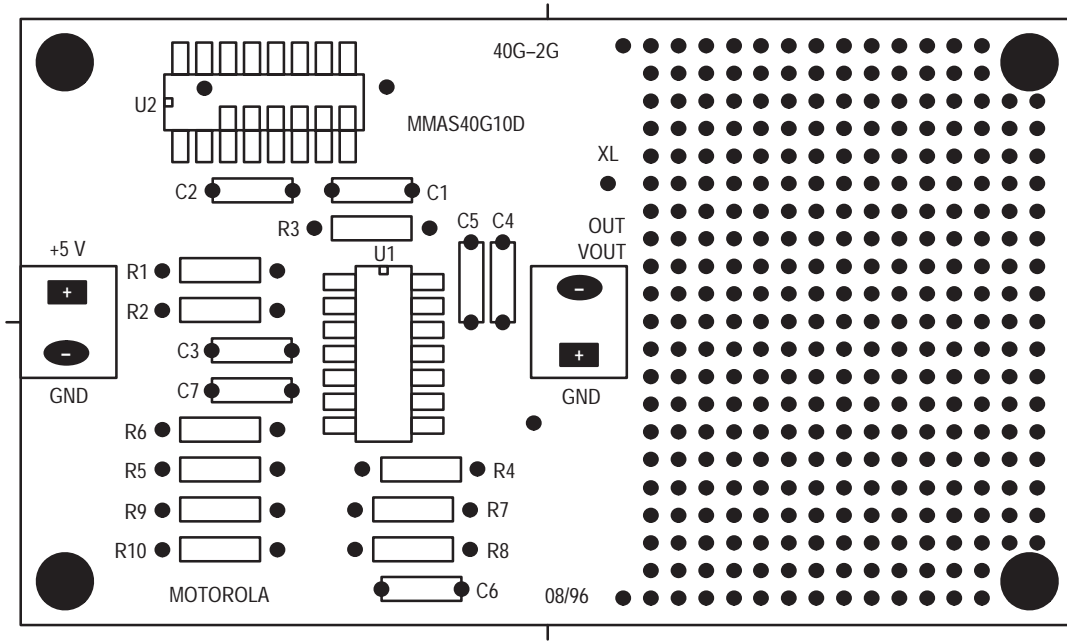



Figure 5. Silk Screen

Motorola reserves the right to make changes without further notice to any products herein. Motorola makes no warranty, representation or guarantee regarding the suitability of its products for any particular purpose, nor does Motorola assume any liability arising out of the application or use of any product or circuit, and specifically disclaims any and all liability, including without limitation consequential or incidental damages. "Typical" parameters which may be provided in Motorola data sheets and/or specifications can and do vary in different applications and actual performance may vary over time. All operating parameters, including "Typicals" must be validated for each customer application by customer's technical experts. Motorola does not convey any license under its patent rights nor the rights of others. Motorola products are not designed, intended, or authorized for use as components in systems intended for surgical implant into the body, or other applications intended to support or sustain life, or for any other application in which the failure of the Motorola product could create a situation where personal injury or death may occur. Should Buyer purchase or use Motorola products for any such unintended or unauthorized application, Buyer shall indemnify and hold Motorola and its officers, employees, subsidiaries, affiliates, and distributors harmless against all claims, costs, damages, and expenses, and reasonable attorney fees arising out of, directly or indirectly, any claim of personal injury or death associated with such unintended or unauthorized use, even if such claim alleges that Motorola was negligent regarding the design or manufacture of the part. Motorola and  are registered trademarks of Motorola, Inc. Motorola, Inc. is an Equal Opportunity/Affirmative Action Employer.

Mfax is a trademark of Motorola, Inc.

**How to reach us:**

**USA/EUROPE/Locations Not Listed:** Motorola Literature Distribution; P.O. Box 5405, Denver, Colorado 80217. 1-303-675-2140 or 1-800-441-2447

**JAPAN:** Nippon Motorola Ltd.; SPD, Strategic Planning Office, 141, 4-32-1 Nishi-Gotanda, Shinagawa-ku, Tokyo, Japan. 81-3-5487-8488

**Customer Focus Center: 1-800-521-6274**

**Mfax™:** RMFAX0@email.sps.mot.com – TOUCHTONE 1-602-244-6609  
 Motorola Fax Back System – US & Canada ONLY 1-800-774-1848  
 –http://sps.motorola.com/mfax/

**ASIA/PACIFIC:** Motorola Semiconductors H.K. Ltd.; 8B Tai Ping Industrial Park, 51 Ting Kok Road, Tai Po, N.T., Hong Kong. 852-26629298

**HOME PAGE:** <http://motorola.com/sps/>

