

# AN1105

## A Digital Pressure Gauge Using the Motorola MPX700 Series Differential Pressure Sensor

Prepared by: Anthony J. Caristi

### INTRODUCTION

This application note describes a solid state digital pressure gauge which is composed of the Motorola MPX series transducer, instrumentation amplifier, A/D converter, and LCD readout. Differential, gauge, and vacuum pressure readings from 0 to 100 PSI with resolution of 1 PSI are possible using the MPX700 sensor. The circuit is also capable of measuring and displaying pressures as low as 1 PSI full scale, and resolution as fine as of 0.01 PSI, by using a more sensitive MPX series pressure transducer and full display capability of the A/D converter.

The Motorola MPX series of pressure transducers is a family of piezoresistive transducers which exhibits a very linear and accurate output voltage relationship that is directly proportional to the applied pressure. The sensor consists of an etched silicon diaphragm upon which a single piezoresistive element is implanted. The resistor senses the stress placed upon the silicon diaphragm by external pressure, and produces a linear output voltage which is proportional to the applied pressure. The output voltage/pressure relationship is ratiometric with the supply voltage feeding the sensor.

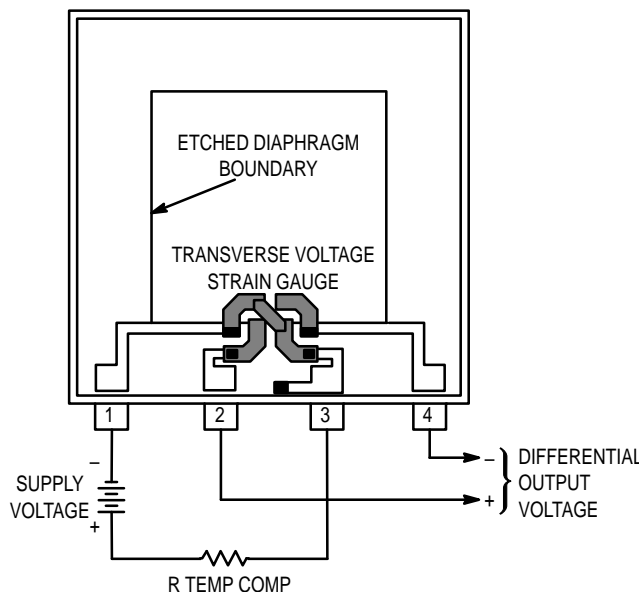

**Figure 1. Sensor Construction Showing Electrical Connections**

The pressure sensor is available as a differential gauge device in a pressure side ported, vacuum side ported, or differential configuration. The following describes an REV 1

application using the MPX700DP differential sensor to measure and display gauge pressure, vacuum (negative pressure), or differential pressure.

### BASIC STRUCTURE

Figure 1 illustrates the top view of the pressure sensor silicon chip, showing the strain-gauge resistor diagonally placed on the edge of the diaphragm. Voltage is applied across pins 1 and 3, while the taps that sense the voltage differential transversely across the pressure sensitive resistor are connected to terminals 2 and 4. An external series resistor is used to provide temperature compensation while reducing the voltage impressed upon the sensor to within its rated value.

### OPERATION

Recommended voltage drive is 3 Vdc, and should not exceed 6 volts under any operating condition. The differential voltage output of the sensor, appearing between terminals 2 and 4, will be positive when the pressure applied to the "pressure" side of the sensor is greater than the pressure applied to the "vacuum" side. Nominal full scale span of the transducer is 60 millivolts when driven by a 3 volt constant voltage source.

When zero pressure is applied to the sensor there will be some output voltage, called zero pressure offset. For the MPX700 sensor this voltage is guaranteed to be within the range of zero to 35 millivolts. The zero pressure offset output voltage is easily nulled out by a suitable instrumentation amplifier. The output voltage of the sensor will vary in a linear manner with applied pressure. Figure 2 illustrates output voltage versus pressure differential applied to the sensor, when driven by a 3 volt source.

### TEMPERATURE COMPENSATION

As illustrated in Figure 2, the output voltage of the sensor will be affected by the temperature of the device. Temperature compensation may easily be accomplished by one of several methods. A full discussion of these methods is covered in Motorola application note AN840.

The simplest method of temperature compensation, placing a resistance (R19 and R20) in series with the sensor driving voltage, is utilized in the schematic diagram illustrated in Figure 3. This provides good results over a temperature span of 0 to 80°C, yielding a 0.5% full scale span compensated device. Since the desired bridge driving voltage is about 3 volts, placing the temperature compensating resistor in series with the bridge circuit has the additional advantage of reducing the power supply voltage, 15 volts, to the desired 3 volt level.

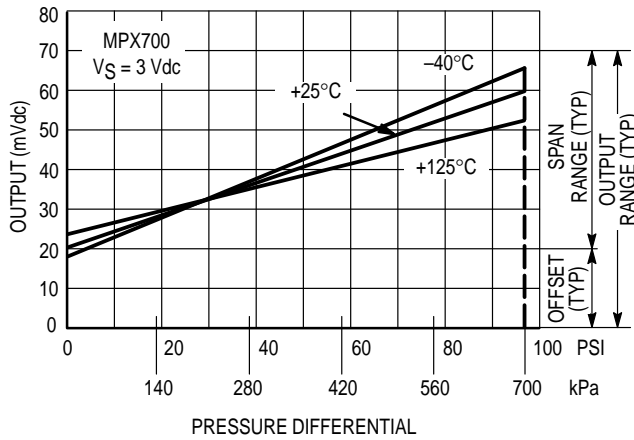

Figure 2. Output versus Pressure Differential

Note that the 15 volt power source must be held to within a tight tolerance, since the output voltage of the transducer is ratiometric with the the supply voltage. In most applications an ordinary fixed 15 volt regulator chip can be used to provide the required stable supply voltage.

The series method of compensation requires a series resistor which is equal to 3.577 times the bridge input resistance at 25 degrees Celsius. The range of transducer resistance is between 400 and 550 ohms, so the compensating network will be 1431 to 1967 ohms. If a temperature compensated span of greater than plus or minus 0.5% is satisfactory or the operating temperature range of the

circuit is less than 80 degrees Celsius, one value of compensating resistance can be used for any sensor resistance over the range of 400 and 550 ohms.

In the circuit of Figure 3 the temperature compensating network is composed of two resistors to allow the quiescent voltage of the sensor at pins 2 and 4 to be near the center level (2.5 volts) of the analog and digital circuit that follows.

### SENSOR AMPLIFIER

An amplifier is used to convert the low level differential output of the transducer, 60 millivolts at 100 PSI, to a useful level that can drive subsequent circuitry. Additionally, the amplifier must provide means to null out the DC offset output voltage of the transducer when zero pressure is applied. The circuit illustrated in Figure 3 uses three sections of a common op-amp chip, LM324N, for this purpose. The high input impedance of operational amplifiers IC1A and IC1B ensures that the circuit does not load the basic transducer.

The gain of the instrumentation amplifier is adjusted by means of potentiometer R6 to allow full scale calibration at 100 PSI applied pressure. Using the circuit constants indicated in Figure 3, the gain of the amplifier can be expressed as

$$A = 2(1 + 100K/R)$$

where A = circuit gain

R = the total resistance composed of R6 plus R7  
 100K = the circuit value represented by R8, R9, R10 and R12.

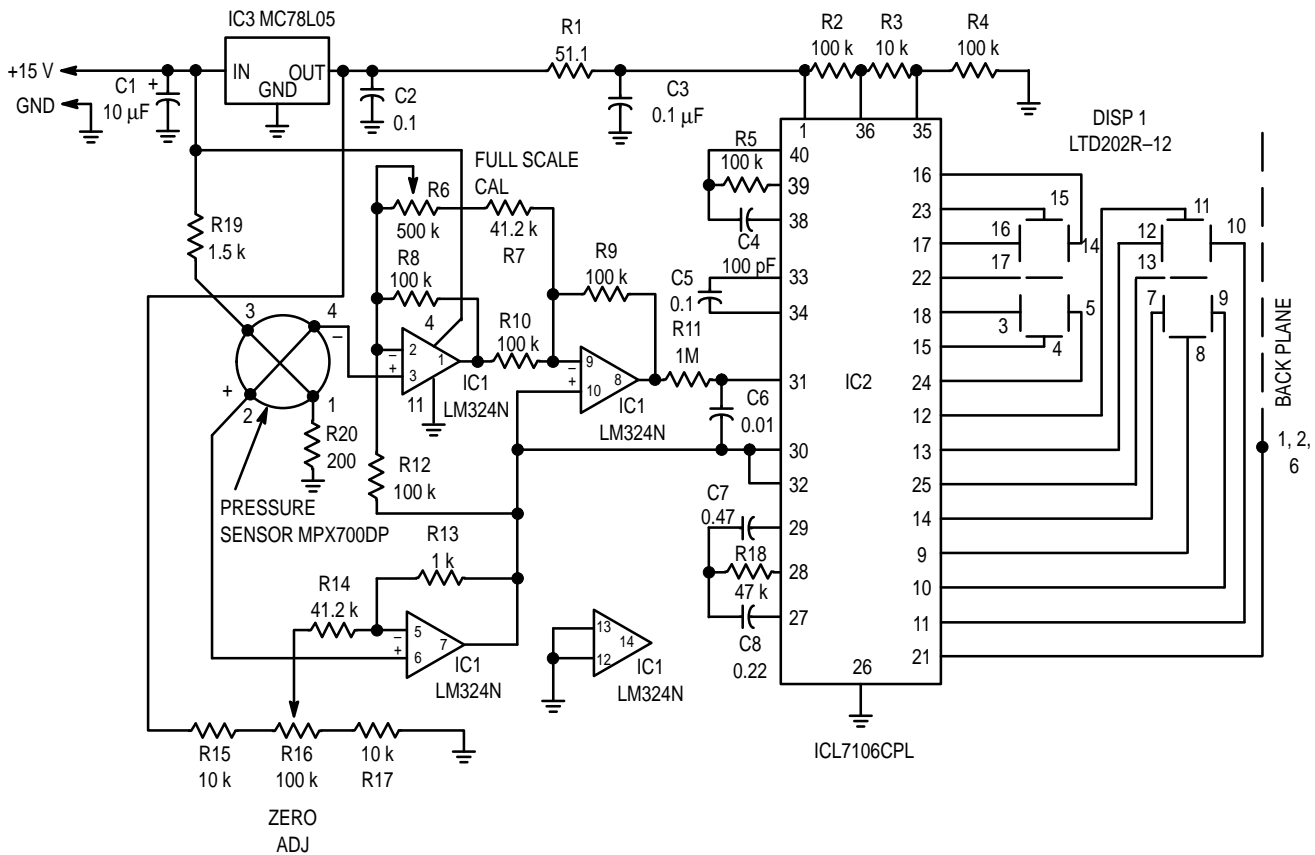

Figure 3. Schematic Diagram of Digital Pressure Gauge

As can be seen by the gain equation, the minimum value of gain is 2 when R is infinite. The amplifier is capable of providing a gain of 100 or more by adjustment of R6, and R7, but in this application the required gain is within the range of about 2.6 to 5.3 to accommodate the tolerance of the full scale span of the sensor.

A voltage divider composed of R15, R16, and R17 provides an adjustable voltage which is fed to the inverting input of IC1B. This voltage, attenuated by the gain of less than 1 of IC1B, is fed to the analog to digital converter chip to negate the effect of the offset voltage produced by the sensor and allows the display of the circuit to read 00 when no pressure is applied. The differential output of the instrumentation amplifier appears between pins 7 and 8 of IC1. This is fed to the analog to digital converter, IC2, to provide a digital readout of the pressure difference impressed upon the transducer.

### A/D CONVERTER

The circuit employs a high performance 3 1/2 digit A/D converter chip (IC2) which contains all the necessary active devices to convert the differential analog output voltage of the instrumentation amplifier to digital form. A pair of LCD digits is directly driven without multiplexing.

Included in IC2 are seven segment decoders, display drivers, backplane frequency generator, reference, and clock. The chip is capable of driving a 3 1/2 digit LCD non-multiplexed display. In this application the least and most significant digits are not used, but if greater range and/or resolution is desired the unused output terminals of the chip can be wired to drive 1 1/2 additional digits.

Full scale output of IC2 (2000 counts) is attained when the analog differential input voltage fed to pins 30 and 31 is equal to twice the reference voltage applied to pins 35 and 36, the differential reference input terminals. In this application the voltage divider composed of R2, R3, and R4, driven by the on-board 5 volt regulator, provides an arbitrary reference

voltage of 238 millivolts. Since the maximum desired digital display occurs at 1000 counts (half of A/D converter full scale capability) for a display of 00 at 100 PSI, the maximum analog input voltage to IC2 will be 238 millivolts. Thus, nominal amplifier circuit gain must be 238/60, or about 4. The two least significant digits of input pressures exceeding 100 PSI will be displayed by the readout.

IC2 responds to both positive and negative analog input voltages, and generates a polarity bit at pin 20. If desired, the circuit can be used to measure both positive and negative differential pressures, with the polarity output bit at pin 20 used to activate a minus sign indicator for negative pressures.

The circuit of Figure 4 employs only two digits of the possible 3 1/2 digit capability of IC2. By substituting a 3 1/2 digit LCD display, the resolution of the pressure reading is increased by a factor of ten. Additionally, any input pressure of 100 PSI or greater will result in the most significant digit, "1", being displayed. Figure 4 illustrates the connections between the A/D converter and the optional 3 1/2 digit LCD display.

### CIRCUIT ASSEMBLY

The terminals of the pressure sensor should be carefully formed to allow insertion into the PC board. Observe the location of pin 1 of the sensor, which is identified by a small notch. Use suitable hardware to mount the unit, being careful not to over tighten the screws and damage the plastic housing. To ensure circuit stability, use metal film resistors throughout the amplifier circuit. The only exception to this are the resistors associated with the A/D converter, R5, R11, and R18, which can be ordinary carbon types.

It is recommended to use sockets for IC1 and IC2.

A small identifier notch is located on the front of the display to identify the location of pin 1, similar to that of a DIP IC chip. This component is constructed of glass and must be handled carefully to avoid breakage.

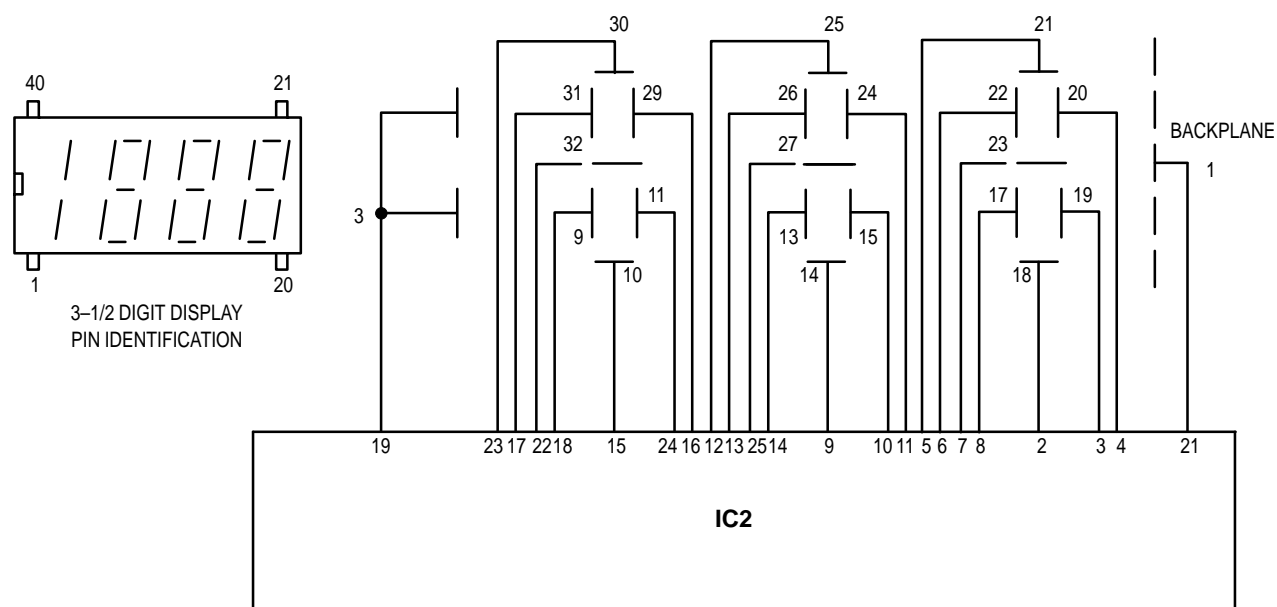

Figure 4. IC2 Driving Optional 3-1/2 Digit LCD Display

## PRESSURE CONNECTIONS

For gauge pressure measurements, the port which is closest to pin 4 of the sensor (identified as P1 in Figure 5) is to be used, with the other port left open to the atmosphere. For vacuum measurements, use port P2, with the opposite port open to the atmosphere.

When the unit is to be used for differential pressure measurements, both ports are used. Positive pressure readings will be obtained when the pressure applied to the high pressure side, P1, is greater than that applied to the low pressure side P2. Should the pressures be opposite the display will still read the difference in pressure, and the A/D converter will output a polarity bit at pin 20 of the chip.

Hoses should be attached to the sensor using a suitable clamp. 100 PSI is a substantial pressure and any hose which is not secured properly can suddenly disconnect.

## CALIBRATION

Calibration of the circuit consists of adjustment of the zero set and span adjust potentiometers, R16 and R6 respectively. A pressure source of up to 100 PSI and accurate pressure gauge is required. Figure 6 illustrates the test setup. Since the output voltage of the sensor is dependent upon the magnitude

of the power supply voltage, calibration of the circuit must be performed with the circuit being driven by a regulated 15 volt supply. Any variation in the supply voltage will cause a proportional error in calibration. With the circuit operating and no pressure applied to the sensor, adjust R16 for a display of 00. Note that the display will read upscale when R16 is set to either side of zero.

Connect the sensor to the pressure source as indicated in Figure 6. Use a reference pressure gauge of known accuracy, and adjust the pressure to 100 PSI. The pressure sensor is capable of withstanding pressures up to 300 PSI without damage.

Adjust R6 for a display of 00, indicating 100 PSI. Since the A/D converter is capable of displaying readings greater than 100, adjustment of R6 is easily set between a display of 99 and 01.

Remove the pressure from the sensor and recheck the setting of the zero set potentiometer. Readjust if necessary for a display of 00. Check the pressure display at 100 PSI. This completes calibration of the circuit.

The digital pressure gauge may be checked over its range by applying any pressure between 0 and 100 PSI and comparing the display to the reference gauge. Note that pressures above 100 PSI will be indicated, but with reduced accuracy.

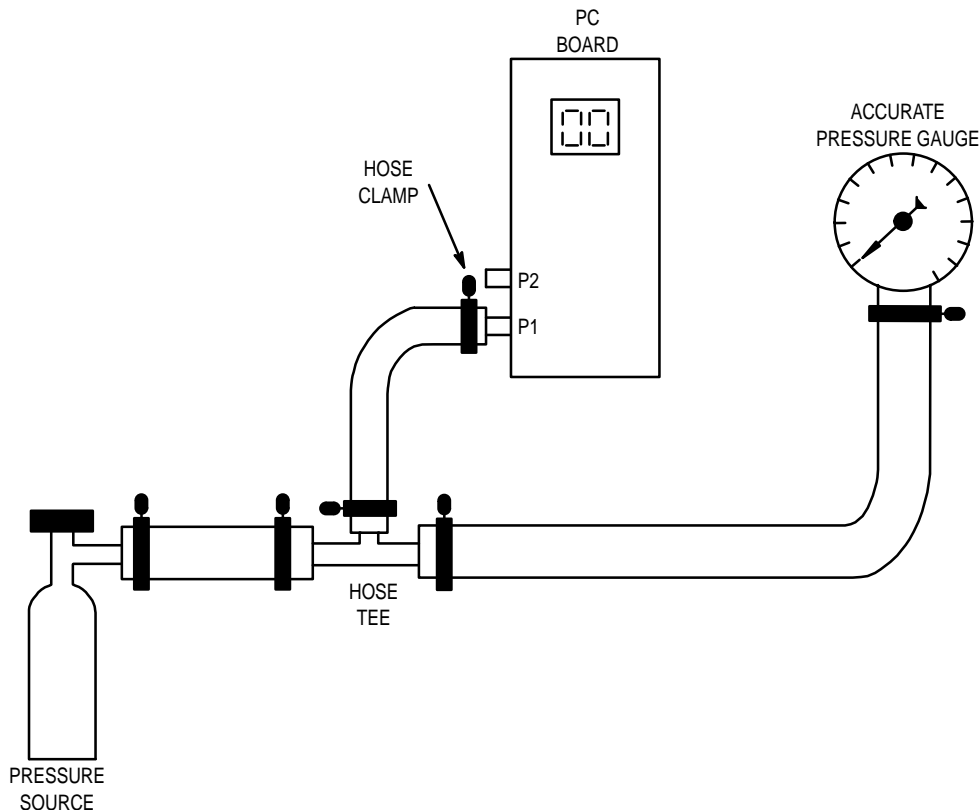

Figure 5. Setup to Calibrate Circuit Against a Known Accurate Pressure Gauge

Table 1. Parts List by Component Values and Part Numbers

| Designators              | Quantity | Description                                 | Rating         | Tolerance | Manufact.       | Part Number |
|--------------------------|----------|---|----------------|-----------|-----------------|-------------|
| C1                       | 1        | 25 volt electrolytic capacitor              | 10 $\mu$ Fd    |           |                 |             |
| C2, C3, C5               | 3        | 50 volt ceramic disc capacitor              | 0.1 $\mu$ Fd   |           |                 |             |
| C4                       | 1        | 50 volt ceramic disc capacitor              | 100 pF         |           |                 |             |
| C6                       | 1        | 50 volt ceramic disc capacitor              | 0.01 $\mu$ Fd  |           |                 |             |
| C7                       | 1        | 50 volt ceramic disc capacitor              | 0.47 $\mu$ Fd  |           |                 |             |
| C8                       | 1        | 50 volt ceramic disc capacitor              | 0.22 $\mu$ F   |           |                 |             |
| DISP                     | 1        | 2 digit LCD readout                         |                |           | Amperex         | LTD202R-12  |
| (optional) DISP          | 1        | 3 1/2 digit LCD readout                     |                |           | Amperex         | LTD221R-12  |
| IC1                      | 1        | Quad operational amplifier                  |                |           | Harris Teledyne | ICL7106CPL  |
| IC2                      |          | A/D converter                               |                |           |                 |             |
| IC3                      | 1        | 100 mA fixed regulator                      | 5 volt         |           | Motorola        | MC78L05     |
| R1                       | 1        | 1/4 watt metal film resistor                | 51.1 $\Omega$  | 1%        |                 |             |
| R2, R4, R8, R9, R10, R12 | 6        | 1/4 watt metal film resistor                | 100 K          | 1%        |                 |             |
| R3, R15, R17             | 3        | 1/4 watt metal film resistor                | 10 K           | 1%        |                 |             |
| R7, R14                  | 2        | 1/4 watt metal film resistor                | 41.2 K         | 1%        |                 |             |
| R13                      | 1        | 1/4 watt metal film resistor                | 1 K            | 1%        |                 |             |
| R19                      | 1        | 1/4 watt metal film resistor                | 1.5 K          | 1%        |                 |             |
| R20                      | 1        | 1/4 watt metal film resistor                | 200 $\Omega$   | %         |                 |             |
| R5                       | 1        | 1/4 watt carbon resistor                    | 100 K          | 5%        |                 |             |
| R11                      | 1        | 1/4 watt carbon resistor                    | 1 meg $\Omega$ | 5%        |                 |             |
| R18                      | 1        | 1/4 watt carbon resistor                    | 47 K           | 5%        |                 |             |
| R6                       | 1        | 0.3 watt cermet potentiometer,<br>PC mount  | 500 K          |           |                 |             |
| R16                      | 1        | 0.3 watt cermet potentiometer,<br>PC mount  | 100 K          |           |                 |             |
| Sensor                   | 1        | 0-100 psi, uncompensated<br>pressure sensor |                |           | Motorola        | MPX700DP    |

Motorola reserves the right to make changes without further notice to any products herein. Motorola makes no warranty, representation or guarantee regarding the suitability of its products for any particular purpose, nor does Motorola assume any liability arising out of the application or use of any product or circuit, and specifically disclaims any and all liability, including without limitation consequential or incidental damages. "Typical" parameters which may be provided in Motorola data sheets and/or specifications can and do vary in different applications and actual performance may vary over time. All operating parameters, including "Typicals" must be validated for each customer application by customer's technical experts. Motorola does not convey any license under its patent rights nor the rights of others. Motorola products are not designed, intended, or authorized for use as components in systems intended for surgical implant into the body, or other applications intended to support or sustain life, or for any other application in which the failure of the Motorola product could create a situation where personal injury or death may occur. Should Buyer purchase or use Motorola products for any such unintended or unauthorized application, Buyer shall indemnify and hold Motorola and its officers, employees, subsidiaries, affiliates, and distributors harmless against all claims, costs, damages, and expenses, and reasonable attorney fees arising out of, directly or indirectly, any claim of personal injury or death associated with such unintended or unauthorized use, even if such claim alleges that Motorola was negligent regarding the design or manufacture of the part. Motorola and  are registered trademarks of Motorola, Inc. Motorola, Inc. is an Equal Opportunity/Affirmative Action Employer.

Mfax is a trademark of Motorola, Inc.

**How to reach us:**

**USA/EUROPE/Locations Not Listed:** Motorola Literature Distribution;  
P.O. Box 5405, Denver, Colorado 80217. 303-675-2140 or 1-800-441-2447

**JAPAN:** Nippon Motorola Ltd.; Tatsumi-SPD-JLDC, 6F Seibu-Butsuryu-Center,  
3-14-2 Tatsumi Koto-Ku, Tokyo 135, Japan. 81-3-3521-8315

**Mfax™:** RMFAX0@email.sps.mot.com – TOUCHTONE 602-244-6609  
– US & Canada ONLY 1-800-774-1848

**ASIA/PACIFIC:** Motorola Semiconductors H.K. Ltd.; 8B Tai Ping Industrial Park,  
51 Ting Kok Road, Tai Po, N.T., Hong Kong. 852-26629298

**INTERNET:** <http://motorola.com/sps>

**MOTOROLA**