

AN1525

The A-B-C's of Signal-Conditioning Amplifier Design for Sensor Applications

Prepared by: Eric Jacobsen and Jeff Baum
Sensor Applications Engineering
Motorola Signal Products Division
Phoenix, AZ

INTRODUCTION

Although fully signal-conditioned, calibrated, and temperature compensated monolithic sensor IC's are commercially available today, there are many applications where the flexibility of designing custom signal-conditioning is of great benefit. Perhaps the need for a versatile low-level sensor output is best illustrated by considering two particular cases that frequently occur: (1) the user is in a prototyping phase of development and needs the ability to make changes rapidly to the overall transfer function of the combined sensor/amplifier subsystem, (2) the specific desired transfer function does not exist in a fully signal-conditioned, precision-trimmed sensor product (e.g., a signal-conditioned device is precision trimmed over a different pressure range than that of the application of interest). In such cases, it is obvious that there will always be a need for low-level, nonsignal-conditioned sensors. Given this need, there is also a need for sensor interface amplifier circuits that can signal condition the "raw" sensor output to a usable level. These circuits should also be user friendly, simple, and cost effective.

Today's unamplified solid-state sensors typically have an output voltage of tens of millivolts (Motorola's basic 10 kPa pressure sensor, MPX10, has a typical full-scale output of 58 mV, when powered with a 5 V supply). Therefore, a gain stage is needed to obtain a signal large enough for additional processing. This additional processing may include digitization by a microcontroller's analog to digital (A/D) converter, input to a comparator, etc. Although the signal-conditioning circuits described here are applicable to low-level, differential-voltage output sensors in general, the focus of this paper will be on interfacing pressure sensors to amplifier circuits.

This paper presents a basic two operational-amplifier signal-conditioning circuit that provides the desired characteristics of an instrumentation amplifier interface:

- High input impedance
- Low output impedance
- Differential to single-ended conversion of the pressure sensor signal
- High gain capability

For this two op-amp circuit, additional modifications to the circuit allow (1) gain adjustment without compromising common mode rejection and (2) both positive and negative dc level shifts of the zero pressure offset. Varying the gain and offset is desirable since full-scale span and zero pressure offset voltages of pressure sensors will vary somewhat from unit to unit. Thus, a variable gain is desirable to fine tune the sensor's full-scale span, and a positive or negative dc level shift (offset adjustment) of the pressure sensor signal is needed to translate the pressure sensor's signal-conditioned output span to a specific level (e.g., within the high and low reference voltages of an A/D converter).

For the two op-amp gain stage, this paper will present the derivation of the transfer function and simplified transfer function for pressure sensor applications, the derivation and explanation of the gain stage with a gain adjust feature, and the derivation and explanation of the gain stage with the dc level shift modification.

Adding another amplifier stage provides an alternative method of creating a negative dc voltage level shift. This stage is cascaded with the output from the two op-amp stage (*Note:* gain of the two op-amp stage will be reduced due to additional gain provided by the second amplifier stage). For this three op-amp stage, the derivation of the transfer function, simplified transfer function, and the explanation of the negative dc level shift feature will be presented.

GENERAL NOTE ON OFFSET ADJUSTMENT

Pressure sensor interface circuits may require either a positive or a negative dc level shift to adjust the zero pressure offset voltage. As described above, if the signal-conditioned pressure sensor voltage is input to an A/D, the sensor's output dynamic range must be positioned within the high and low reference voltages of the A/D; i.e., the zero pressure offset voltage must be greater than (or equal to) the low reference voltage and the full-scale pressure voltage must be less than (or equal to) the high reference voltage (see Figure 1). Otherwise, voltages above the high reference will be digitally converted as 255 decimal (for 8-bit A/D), and voltages below the low reference will be converted as 0. This creates a nonlinearity in the analog-to-digital conversion.

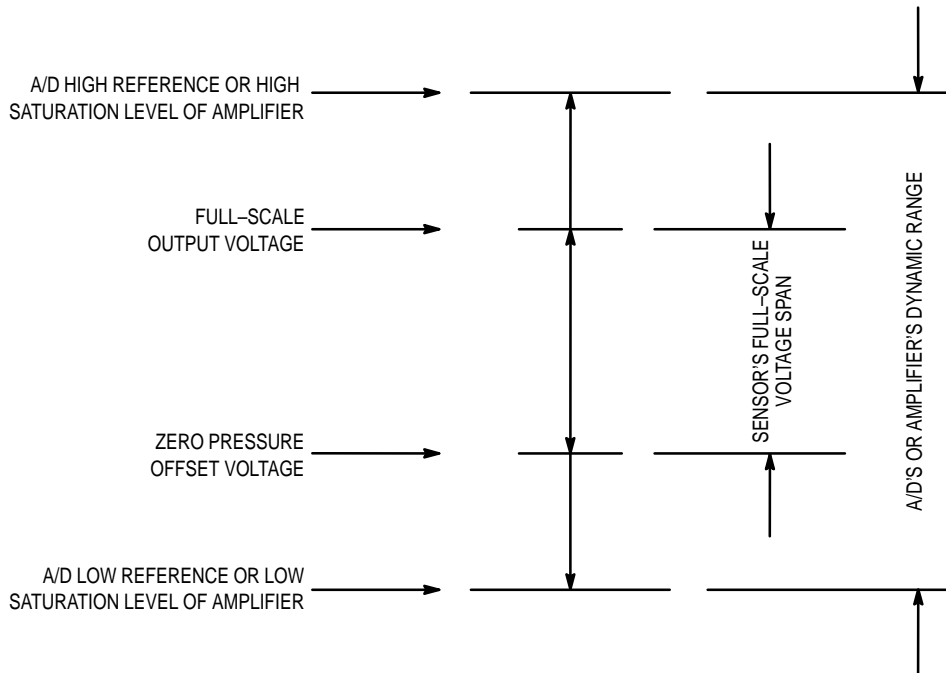

Figure 1. Positioning the Sensor's Full-Scale Span within the A/D's or Amplifier's Dynamic Range

A similar requirement that warrants the use of a dc level shift is the prevention of the pressure sensor's voltage from extending into the saturation regions of the operational amplifiers. This also would cause a nonlinearity in the sensor output measurements. For example, if an op-amp powered with a single-ended 5 V supply saturates near the low rail of the supply at 0.2 V, a positive dc level shift may be required to position the zero pressure offset voltage at or above 0.2 V. Likewise, if the same op-amp saturates near the high rail of the supply at 4.8 V, a negative dc level shift may be required to position the full-scale pressure voltage at or below 4.8 V. It should be obvious that if the gain of the amplifiers is too large, the span may be too large to be positioned within the 4.6 V window (regardless of ability to level shift dc offset). In such a case, the gain must be decreased to reduce the span.

THE TWO OP-AMP GAIN STAGE TRANSFER FUNCTION

The transfer function of the two op-amp signal-conditioning stage, shown in Figure 2, can be determined using nodal analysis at nodes 1 and 2. The analysis can be simplified by calculating the transfer function for each of the signals with the other two signals grounded (set to zero), and then employing superposition to realize the overall transfer function. As shown in Figure 2, V_{IN2} and V_{IN1} are the differential amplifier input signals (with $V_{IN2} > V_{IN1}$), and V_{REF} is the positive dc level adjust point. For a sensor with a small zero pressure offset and operational amplifiers powered from a single-ended supply, it may be necessary to add a positive dc level shift to keep the operational amplifiers from saturating near zero volts.

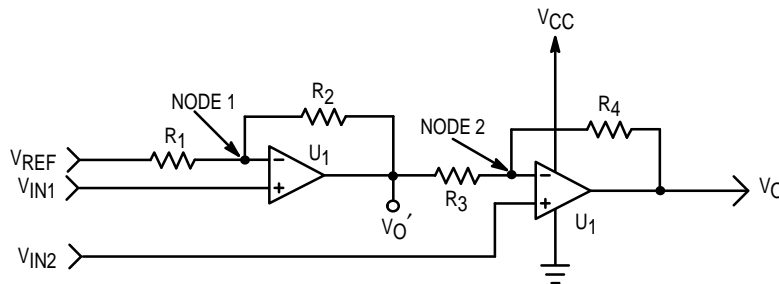

Figure 2. The Two Operational-Amplifier Gain Stage

First, the transfer function for V_{IN1} is determined by grounding V_{REF} and V_{IN2} at node 1:

$$\frac{V_{IN1}}{R_1} = \frac{V_{O'} - V_{IN1}}{R_2} \quad (1)$$

and at node 2:

$$\frac{V_{O'}}{R_3} = -\frac{V_O}{R_4} \quad (2)$$

By solving Equations (1) and (2) for $V_{O'}$ and equating the results, Equation (3) is established:

$$\left(\frac{R_2}{R_1} + 1\right) V_{IN1} = -\frac{R_3}{R_4} V_{O3} \quad (3)$$

Solving for V_{O1} yields

$$V_{O1} = -\frac{R_4}{R_3} \left(\frac{R_2}{R_1} + 1\right) V_{IN1} \quad (4)$$

where V_{O1} represents the part of V_O that V_{IN1} contributes.

To determine the transfer function for V_{IN2} , V_{IN1} and V_{REF} are grounded, and a similar analysis is used, yielding

$$V_{O2} = \left(\frac{R_4}{R_3} + 1\right) V_{IN2} \quad (5)$$

where V_{O2} represents the part of V_O that V_{IN2} contributes.

Finally, to calculate the transfer function between V_O and V_{REF} , V_{IN1} and V_{IN2} are grounded to obtain the following transfer function:

$$V_{OREF} = \frac{R_4 R_2}{R_3 R_1} V_{REF} \quad (6)$$

where V_{OREF} represents the part of V_O that V_{REF} contributes.

Using superposition for the contributions of V_{IN1} , V_{IN2} , and V_{REF} gives the overall transfer function for the signal-conditioning stage.

$$V_O = V_{O1} + V_{O2} + V_{OREF}$$

$$V_O = -\frac{R_4}{R_3} \left(\frac{R_2}{R_1} + 1\right) V_{IN1} + \left(\frac{R_4}{R_3} + 1\right) V_{IN2} + \frac{R_4 R_2}{R_3 R_1} V_{REF} \quad (7)$$

Equation (7) is the general transfer function for the signal-conditioning stage. However, the general form is not only cumbersome, but also if no care is taken to match certain resistance ratios, poor common mode rejection results. A simplified form of this equation that provides good common mode rejection is shown in the next section.

APPLICATION TO PRESSURE SENSOR CIRCUITS

The previous section showed the derivation of the general transfer function for the two op-amp signal-conditioning circuit. The simplified form of this transfer function, as applied to a pressure sensor application, is derived in this section.

For pressure sensors, V_{IN1} and V_{IN2} are referred to as S^- and S^+ , respectively. The simplification is obtained by setting

$$\frac{R_4}{R_3} = \frac{R_1}{R_2}$$

Through this simplification, Equation (7) simplifies to

$$V_O = \left(\frac{R_4}{R_3} + 1\right) (S^+ - S^-) + V_{REF} \quad (8)$$

By examining Equation (8), the differential gain of the signal-conditioning stage is:

$$G = \frac{R_4}{R_3} + 1 \quad (9)$$

Also, since the differential voltage between S^+ and S^- is the pressure sensor's actual differential output voltage (V_{SENSOR}), the following equation is obtained for V_O :

$$V_O = \left(\frac{R_4}{R_3} + 1\right) V_{SENSOR} + V_{REF} \quad (10)$$

Finally, the term V_{REF} is the positive offset voltage added to the amplified sensor output voltage. V_{REF} can only be positive when using a positive single-ended supply. This offset (dc level shift) allows the user to adjust the absolute range that the sensor voltage spans. For example, if the gain established by R_4 and R_3 creates a span of four volts and this signal swing is superimposed upon a dc level shift (offset) of 0.5 volts, then a signal range from 0.5 V to 4.5 V results.

V_{REF} is typically adjusted by a resistor divider as shown in Figure 3. A few design constraints are required when designing the resistor divider to set the voltage at V_{REF} .

- To establish a stable positive dc level shift (V_{REF}), V_{CC} should be regulated; otherwise, V_{REF} will vary as V_{CC} varies.
- When "looking" into the resistor divider from R_1 , the effective resistance of the parallel combination of the resistors, R_{REF1} and R_{REF2} , should be at least an order of magnitude smaller than R_1 's resistance. If the resistance of the parallel combination is not small in comparison to R_1 , R_1 's value will be significantly affected by the parallel combination's resistance. This effect on R_1 will consequently affect the amplifier's gain and reduce the common mode rejection.

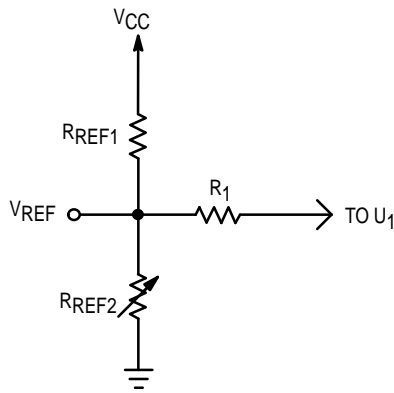

Figure 3. A Resistor Divider to Create VREF

THE TWO OP-AMP GAIN STAGE WITH VARIABLE GAIN

Varying the gain of the two op-amp stage is desirable for fine-tuning the sensor's signal-conditioned output span. However, to adjust the gain in the two op-amp gain circuit in Figure 2 and to simultaneously preserve the common mode rejection, two resistors must be adjusted. To adjust the gain, it is more desirable to change one resistor. By adding an additional feedback resistor, R_G , the gain can be adjusted with this one resistor while preserving the common mode rejection. Figure 4 shows the two op-amp gain stage with the added resistor, R_G .

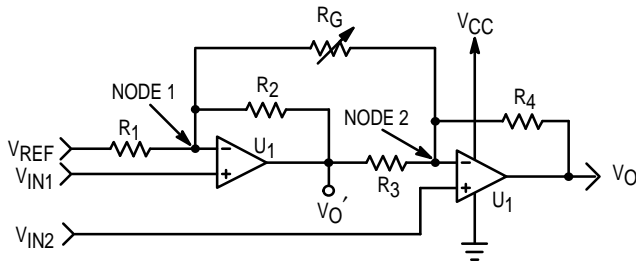

Figure 4. Two Operational-Amplifier Gain Stage with Variable Gain

As with the two op-amp gain stage, nodal analysis and superposition are used to derive the general transfer function for the variable gain stage.

$$\begin{aligned}
 V_O = & \left(\frac{R_4}{R_3} + \frac{R_4}{R_G} + \frac{R_2 R_4}{R_3 R_G} + 1 \right) V_{IN2} \\
 & - \left(\frac{R_4}{R_3} + \frac{R_4}{R_G} + \frac{R_2 R_4}{R_3 R_G} + \frac{R_2 R_4}{R_1 R_3} \right) V_{IN1} \\
 & + \left(\frac{R_2 R_4}{R_1 R_3} \right) V_{REF} \quad (11)
 \end{aligned}$$

This general transfer function also is quite cumbersome and is susceptible to producing poor common mode rejection

without additional constraints on the resistor values. To obtain good common mode rejection, use a similar simplification as before; that is, set

$$R_1 = R_4$$

and

$$R_2 = R_3$$

Defining the voltage differential between V_{IN2} and V_{IN1} as V_{SENSOR} , the simplified transfer function is

$$V_O = \left(\frac{R_4}{R_3} + \frac{2R_4}{R_G} + 1 \right) (V_{SENSOR}) + V_{REF} \quad (12)$$

Thus, the gain is

$$G = \frac{R_4}{R_3} + \frac{2R_4}{R_G} + 1 \quad (13)$$

and V_{REF} is the positive dc level shift (offset).

Use the following guidelines when determining the value for R_G :

- By examining the gain equation, R_G 's resistance should be comparable to R_4 's resistance. This will allow fine tuning of the gain established by R_4 and R_3 . If R_G is too large (e.g., R_G approaches ∞), it will have a negligible effect on the gain. If R_G is too small (e.g., R_G approaches zero), the R_G term will dominate the gain expression, thus prohibiting fine adjustment of the gain established via the ratio of R_4 and R_3 .
- Use a potentiometer for R_G that has a resistance range on the order of R_4 (perhaps with a maximum resistance equal to the value of R_4). If a fixed resistor is preferable to a potentiometer, use the potentiometer to adjust the gain, measure the potentiometer's resistance, and replace the potentiometer with the closest 1% resistor value.
- To maintain good common mode rejection while varying the gain, R_G should be the only resistor that is varied. R_G equally modifies both of the resistor ratios which need to be well-matched for good common mode rejection, thus preserving the common mode rejection.

THE TWO OP-AMP GAIN STAGE WITH VARIABLE GAIN AND NEGATIVE DC LEVEL SHIFT

The last two op-amp circuits both incorporate positive dc level shift capability. Recall that a positive dc level shift is required to keep the operational amplifiers from saturating near the low rail of the supply or to keep the zero pressure offset above (or equal to) the low reference voltage of an A/D. This two op-amp stage incorporates an additional resistor, R_{OFF} , to provide a negative dc level shift. A negative dc level shift is useful when the zero pressure offset voltage of the sensor is too high. In this case, the user may be required to level shift the zero pressure offset voltage down (toward zero volts). Now, for a specified amount of gain, the full-scale pressure output voltage does not saturate the amplifier at the high rail of the voltage supply, nor is it greater than the A/D's high reference voltage. Figure 5 shows the schematic for this amplifier circuit.

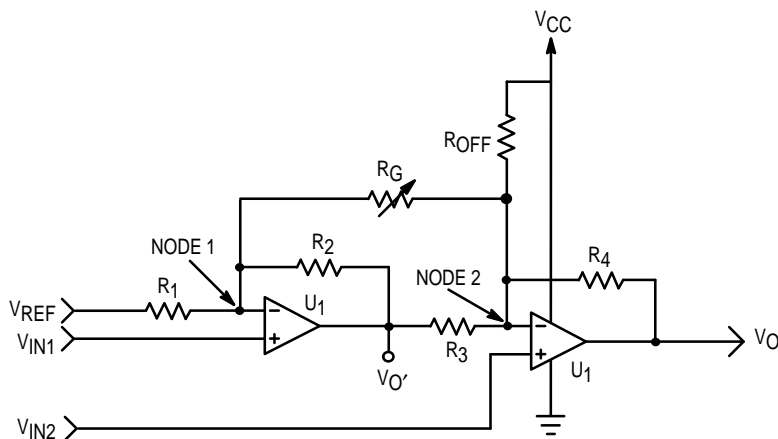

Figure 5. Two Op–Amp Signal–Conditioning Stage with Variable Gain and Negative Dc Level Shift Adjust

To derive the general transfer function, nodal analysis and superposition are used:

$$V_O = \left(\frac{R_4}{R_3} + \frac{R_4}{R_G} + \frac{R_2 R_4}{R_3 R_G} + 1 \right) V_{IN2} - \left(\frac{R_4}{R_3} + \frac{R_4}{R_G} + \frac{R_2 R_4}{R_1 R_3} + \frac{R_2 R_4}{R_3 R_G} \right) V_{IN1} + \left(\frac{R_2 R_4}{R_1 R_3} \right) V_{REF} + \frac{R_4}{R_{OFF}} (V_{IN2} - V_{CC}) \quad (14)$$

As before, defining the sensor's differential output as V_{SENSOR} , defining V_{IN2} as S^+ for pressure sensor applications, and using the simplification that

$$R_1 = R_4$$

and

$$R_2 = R_3$$

obtains the following simplified transfer function:

$$V_O = \left(\frac{R_4}{R_3} + \frac{2R_4}{R_G} + 1 \right) (V_{SENSOR}) + V_{REF} + \frac{R_4}{R_{OFF}} (S^+ - V_{CC}) \quad (15)$$

The gain is

$$G = \frac{R_4}{R_3} + \frac{2R_4}{R_G} + 1 \quad (16)$$

To adjust the gain, refer to the guidelines presented in the section on Two Op–Amp Gain Stage with Variable Gain.

V_{REF} is the positive dc level shift, and the negative dc level shift is:

$$V_{-shift} = \frac{R_4}{R_{OFF}} (S^+ - V_{CC}) \quad (17)$$

The following guidelines will help design the circuitry for the negative dc voltage level shift:

- To establish a stable negative dc level shift, V_{CC} should be regulated; otherwise, the amount of negative level shift will vary as V_{CC} varies.
- R_{OFF} should be the only resistor varied to adjust the negative level shift. Varying R_4 will change the gain of the two op–amp circuit and reduce the common mode rejection.
- To determine the value of R_{OFF} :
 - Determine the amount of negative dc level shifting required (defined here as V_{-shift}).
 - R_4 already should have been determined to set the gain for the desired signal–conditioned sensor output.
 - Although V_{-shift} is dependent on S^+ , S^+ changes only slightly over the entire pressure range. With Motorola's MPX10 powered at a 5 V supply, S^+ will have a value of approximately 2.51 V at zero pressure and will increase as high as 2.53 V at full–scale pressure. This error over the full–scale pressure span of the device is negligible when considering that many applications use an 8–bit A/D converter to segment the pressure range. Using an 8–bit A/D, the 20 mV (0.02 V) error corresponds to only 1 bit of error over the entire pressure range (1 bit / 255 bits \times 100% = 0.4% error).
 - R_{OFF} is then calculated by the following equation:

$$R_{OFF} = \frac{S^+ - V_{CC}}{V_{-shift}} R_4 \quad (18)$$

An alternative to using this equation is to use a potentiometer for R_{OFF} that has a resistance range on the order of R_4 (perhaps 1 to 5 times the value of R_4). Use the potentiometer to fine tune the negative dc level shift, while monitoring the zero pressure offset output voltage, V_O . As before, if a fixed resistor is preferable, then measure the potentiometer's resistance and replace the potentiometer with the closest 1% resistor value.

Important note: The common mode rejection of this amplifier topology will be low and perhaps unacceptable in some applications. (A SPICE model of this amplifier topology showed the common mode rejection to be 28 dB.) However, this circuit is presented as a solution for applications where only two operational amplifiers are available and the common mode rejection is not critical when considering the required

AN1525

system performance. Adding a third op-amp to the circuit for the negative dc level shifting capability (as shown in the next section) is a solution that provides good common mode rejection, but at the expense of adding an additional op-amp.

THE THREE OP-AMP GAIN STAGE FOR NEGATIVE DC LEVEL SHIFTING

This circuit adds a third op-amp to the output of the two op-amp gain block (see Figure 6). This op-amp has a dual function in the overall amplifier circuit:

- Its non-inverting configuration provides gain via the ratio of R_6 and R_5 .
- It has negative dc voltage level shifting capability typically created by a resistor divider at V_{-shift} , as discussed in the section on Application to Pressure Sensor Circuits. Although this configuration requires a third op-amp for the negative dc level shift, it has no intrinsic error nor low common mode rejection associated with the negative level shift (as does the previous two op-amp stage). Depending on the application's accuracy requirement, this may be a more desirable configuration for providing the negative dc level shift.

First, use the same simplifications as before; that is, set

$$R_1 = R_4$$

and

$$R_2 = R_3$$

Defining the voltage differential between V_{IN2} and V_{IN1} as V_{SENSOR} , the simplified transfer function is

$$V_O = \left[1 + \frac{R_6}{R_5} \right] \left[\left(\frac{R_4}{R_3} + \frac{2R_4}{R_G} + 1 \right) (V_{SENSOR}) + V_{REF} \right] - \frac{R_6}{R_5} V_{-shift} \quad (20)$$

The gain is

$$G = \left[1 + \frac{R_6}{R_5} \right] \left[\frac{R_4}{R_3} + \frac{2R_4}{R_G} + 1 \right] \quad (21)$$

V_{REF} is the positive dc level shift (offset), and V_{-shift} is the negative dc level shift.

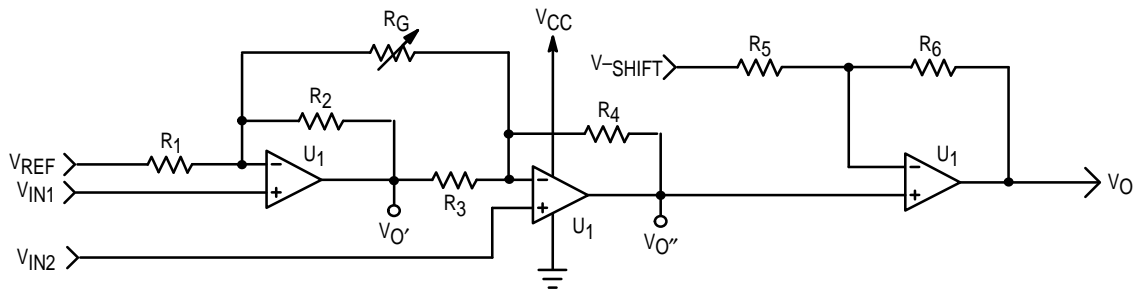

Figure 6. Three Op-Amp Gain Stage with Variable Gain and Negative Dc Level Shift

The transfer function for this stage will be similar to the chosen two op-amp gain stage configuration (either the fixed gain with positive dc level shift circuit or the variable gain with positive dc level shift circuit) with additional terms for the negative level shift and gain. As an example, the variable-gain two op-amp gain circuit is used here. All of the design considerations and explanations for the variable gain two op-amp circuit apply.

The transfer function may be derived with nodal analysis and superposition.

$$V_O = \left[1 + \frac{R_6}{R_5} \right] \left[\left(\frac{R_4}{R_3} + \frac{R_4}{R_G} + \frac{R_2 R_4}{R_3 R_G} + 1 \right) V_{IN2} - \left(\frac{R_4}{R_3} + \frac{R_4}{R_G} + \frac{R_2 R_4}{R_3 R_G} + \frac{R_2 R_4}{R_1 R_3} \right) V_{IN1} + \left(\frac{R_2 R_4}{R_1 R_3} \right) V_{REF} \right] - \frac{R_6}{R_5} V_{-shift} \quad (19)$$

The preceding simplifications have been performed in the previous sections, but by examining Equation 20, notice that the third op-amp's gain term also amplifies the positive and negative dc voltage level shifts, V_{REF} and V_{-shift} . If R_6 and R_5 are chosen to make an arbitrary contribution to the overall system gain, designing an appropriate amount of positive and negative dc level shift can be difficult. To simplify the transfer function, set $R_5 = R_6$, and the following equation for V_O results:

$$V_O = 2 \left[\left(\frac{R_4}{R_3} + \frac{2R_4}{R_G} + 1 \right) (V_{SENSOR}) + V_{REF} \right] - V_{-shift} \quad (22)$$

Now the third op-amp's contribution to the overall system gain is a factor of two. When designing the overall system gain and the positive dc level shift, use the following guidelines:

- Since the third op-amp contributes a gain of two to the overall system, design the gain that the two op-amp circuit contributes to the system to be one-half the desired system gain. The gain term for the two op-amp circuit is:

$$G = \frac{R_4}{R_3} + \frac{2R_4}{R_G} + 1$$

which is the same as presented in Equation 16.

- Similarly, since the third op-amp also amplifies V_{REF} by two (refer to Equation 22), the resistor divider that creates V_{REF} should be designed to provide one-half the desired positive dc voltage level shift needed for the final output. When designing the voltage divider for V_{REF} , use the same design constraints as were given in the section on Application to Pressure Sensor Circuits.

With the above simplification of $R_5 = R_6$, the negative dc level shift, V_{-shift} , which is also created by a voltage divider, is now amplified by a factor of unity. When designing the voltage divider, use the same design constraints as were presented in the section on Application to Pressure Sensor Circuits.

CONCLUSION

The amplifier circuits discussed in this paper apply to pressure sensor applications, but the amplifier circuits can be interfaced to low-level, differential-voltage output sensors, in general. All of the circuits exhibit the desired instrumentation amplifier characteristics of high input impedance, low output impedance, high gain capability, and differential to single-ended conversion of the sensor signal. Each amplifier circuit provides positive dc level shift capability, while the last two circuit topologies presented are also able to provide a negative dc voltage level shift. This enables the user to position the sensor's dynamic output within a specified range (e.g., within the high and low references of an A/D converter). Also detailed is a method of using an additional feedback resistor to adjust easily the differential voltage gain, while not sacrificing common mode rejection. Combining the appropriate sensor device and amplifier interface circuit provides sensor users with a versatile system solution for applications in which the ideal fully single-conditioned sensor does not exist or in which such signal flexibility is warranted.

Motorola reserves the right to make changes without further notice to any products herein. Motorola makes no warranty, representation or guarantee regarding the suitability of its products for any particular purpose, nor does Motorola assume any liability arising out of the application or use of any product or circuit, and specifically disclaims any and all liability, including without limitation consequential or incidental damages. "Typical" parameters which may be provided in Motorola data sheets and/or specifications can and do vary in different applications and actual performance may vary over time. All operating parameters, including "Typicals" must be validated for each customer application by customer's technical experts. Motorola does not convey any license under its patent rights nor the rights of others. Motorola products are not designed, intended, or authorized for use as components in systems intended for surgical implant into the body, or other applications intended to support or sustain life, or for any other application in which the failure of the Motorola product could create a situation where personal injury or death may occur. Should Buyer purchase or use Motorola products for any such unintended or unauthorized application, Buyer shall indemnify and hold Motorola and its officers, employees, subsidiaries, affiliates, and distributors harmless against all claims, costs, damages, and expenses, and reasonable attorney fees arising out of, directly or indirectly, any claim of personal injury or death associated with such unintended or unauthorized use, even if such claim alleges that Motorola was negligent regarding the design or manufacture of the part. Motorola and  are registered trademarks of Motorola, Inc. Motorola, Inc. is an Equal Opportunity/Affirmative Action Employer.

Mfax is a trademark of Motorola, Inc.

How to reach us:

USA/EUROPE/Locations Not Listed: Motorola Literature Distribution;
P.O. Box 5405, Denver, Colorado 80217. 303-675-2140 or 1-800-441-2447

JAPAN: Nippon Motorola Ltd.; Tatsumi-SPD-JLDC, 6F Seibu-Butsuryu-Center,
3-14-2 Tatsumi Koto-Ku, Tokyo 135, Japan. 81-3-3521-8315

Mfax™: RMFAX0@email.sps.mot.com – TOUCHTONE 602-244-6609
– US & Canada ONLY 1-800-774-1848

ASIA/PACIFIC: Motorola Semiconductors H.K. Ltd.; 8B Tai Ping Industrial Park,
51 Ting Kok Road, Tai Po, N.T., Hong Kong. 852-26629298

INTERNET: <http://motorola.com/sps>

