

AN1611

Impact and Tilt Measurement Using Accelerometer

Prepared by: C.S. Chua
Sensor Application Engineering
Singapore, A/P

INTRODUCTION

This application note describes the concept of measuring impact and tilt of an object using an accelerometer, microcontroller hardware/software and a liquid crystal display. Due to the wide frequency response of the accelerometer from d.c. to 400Hz, the device is able to measure both the static acceleration from the Earth's gravity and the shock or vibration from an impact. This design uses a 40G accelerometer (Motorola P/N: MMA2200W) yields a minimum acceleration range of -40G to +40G.

CONCEPT OF TILT MEASUREMENT

To measure the tilt or orientation of an object, the accelerometer must be able to respond to d.c. force. This is not possible

for technology like piezoelectric which does not have any d.c. response. As shown in Figure 1, the accelerometer should be mounted in such a way that the axis of sensitivity is parallel to the surface of the Earth. In this way, the output of the accelerometer will vary from -1.0g to +1.0g when the angle θ is tilted from -90° to +90°. The relationship is shown by the equation below:

$$V_{OUT} = V_{off} + \left(\frac{\Delta V}{\Delta G} \times 1.0G \times \sin \theta \right)$$

where:

- V_{OUT} = Output of accelerometer
- V_{off} = Zero accelerometer
- $\Delta V/\Delta G$ = Sensitivity
- 1.0G = Earth's gravity
- θ = Tilt angle

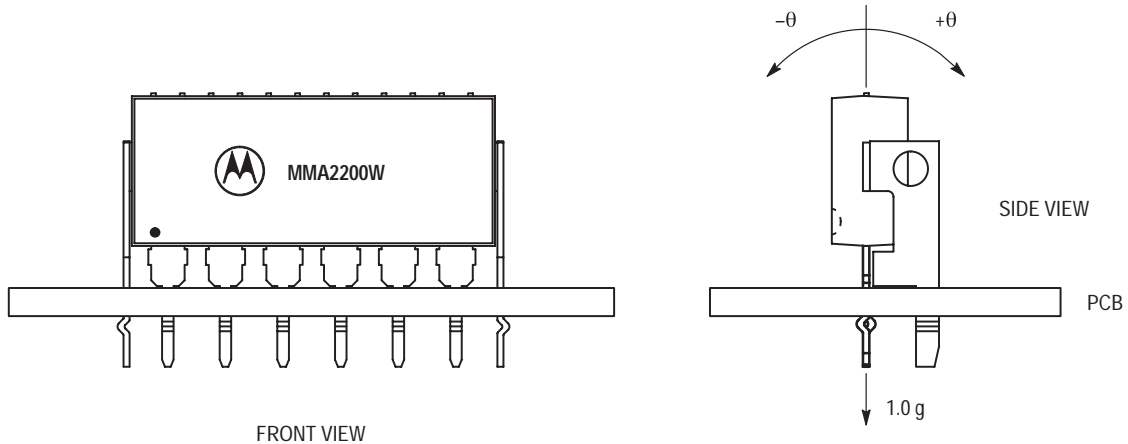

Figure 1. Orientation of Accelerometer

To measure this small changes (i.e. less than 1g over the full span of 40g) in tilt measurement, many sampling data are taken for averaging to eliminate the high frequency component because a tilt information is basically consisting of low frequency component in the order of a few hertz or less. Otherwise, an external low pass filter may be necessary to filter off the a.c. component in order to extract the dc

component. In this design, the resolution is 0.5g due to the limitation of the 8-bit analog-to-digital converter which yields 19.6 mV/step. This is approximately equal to 0.5g as the sensitivity of MMA2200W is 40 mV/g. However, in the presence of an impact, the signal must be processed in a different way as the tilt measurement because peak impact information is a high frequency component.

AN1611

To measure the tilt angle using the equation, we must first solve the sine function. In 'C' language programming, we could use the `asin()` function available in the libraries. However in assembly language, it could be solved via a look-up table or Trigonometric series given by the equation below.

$$\theta = \sin^{-1} \chi = \chi + \frac{\chi^3}{6} + \frac{1 \times 3 \chi^5}{2 \times 4 \times 5} + \frac{1 \times 3 \times 5 \chi^7}{2 \times 4 \times 6 \times 7} + \dots$$

Alternatively, for tilt angle less than 10°, the following

approximation can be used where θ is in radian.

$$\sin \theta = \theta$$

CONCEPT OF IMPACT MEASUREMENT

During an impact, the accelerometer will measure the deceleration experienced by the object from dc to 400Hz. Normally, the peak impact pulse is in the order of a few miniseconds. Figure 2 shows a typical crash waveform of a toy car having a stiff bumper.

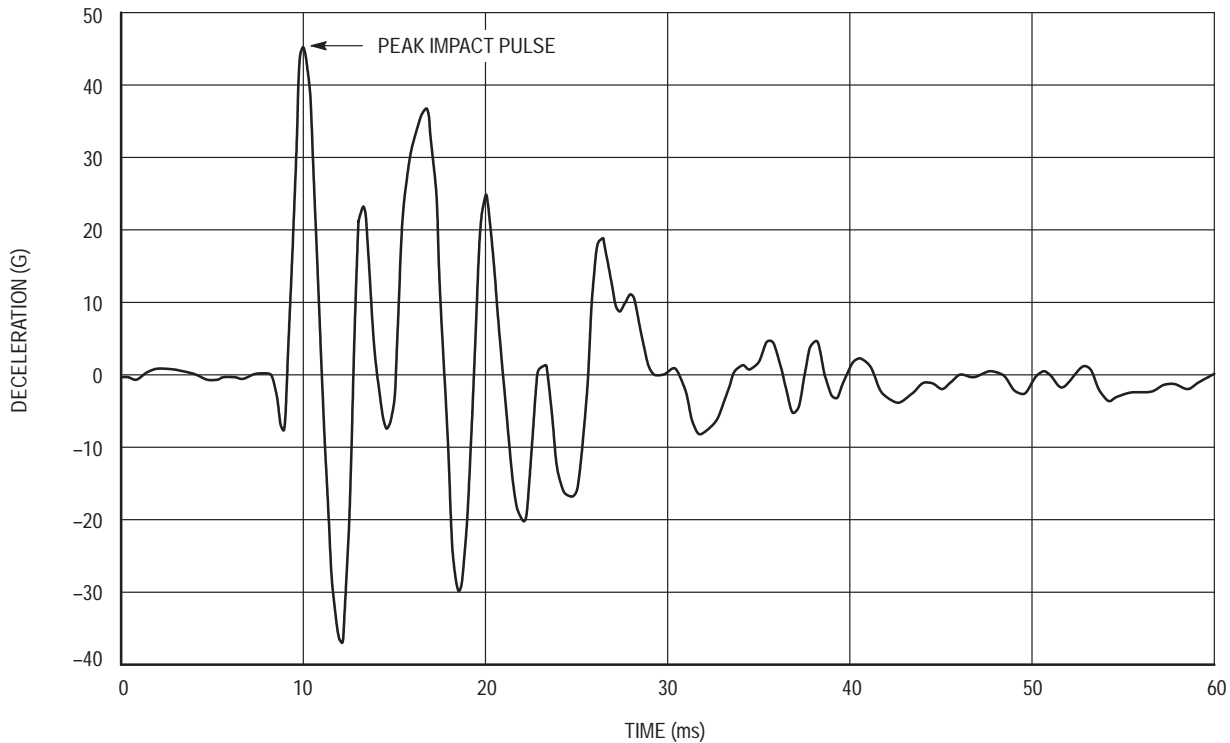

Figure 2. Typical Crash Pattern

To detect the peak of this signal, the sampling rate must be at least twice the signal frequency according to Nyquist Sampling Criterion. From the graph, the signal frequency is approximated to be 300Hz. This implies that the sampling rate must be at least 600Hz. In this design, 32 samples are taken for averaging to eliminate the random noise of the accelerometer. The total time taken for acquire 32 samples and averaging is about 650 μ s which corresponds to 1.5 kHz of sampling frequency. Typically, the accelerometer sampling time is in the order of 500 μ s.

In this design, the vehicle deceleration is measured and compared against a pre-set thresholds of 7g to determine if an LED is required to turn on or not. At the same time, the peak deceleration is display on the LCD for 3 seconds. Presently, most of the airbag system executes a crash discrimination

once the threshold is exceeded. The software routine would then monitor the accelerometer to determine the severity of the crash and the need to deploy bags and/or seat belt pretensioners. The algorithm varies from design to design and is typically set to above certain energy threshold before it calls for a bag deployment. For instance, some design makes use of the equation below which integrates acceleration into velocity signal or jerk of the driver over a period of time. Many other parameters (e.g. change in energy of the vehicle) may also be used at the same time because one parameter is good for one type of crash while the other are good for other types of crashes.

$$\Delta V = \int_0^{T1} a(t) dt$$

HARDWARE DESCRIPTION AND OPERATION

Since MMA2200W is fully signal-conditioned by its internal op-amp and temperature compensation, the output of the accelerometer can be directly interfaced with an analog-to-digital (A/D) converter for digitization. A filter consists of one RC network should be added if the connection between the output of the accelerometer and the A/D converter is a long track or cable. This stray capacitance may change the position of the internal pole which would drive the output amplifier of the accelerometer into oscillation or instability. In this design, the cut-off frequency is chosen to be 15.9 kHz which also acts as an anti-alias filter for the A/D converter. The 3dB frequency can be approximated by the following equation.

$$f_{-3dB} = \frac{1}{2\pi RC}$$

Referring to the schematic, Figure 3, the MMA2200W accelerometer is connected to PORT D bit 5 and the output of the amplifier is connected to PORT D bit 6 of the microcontroller. This port is an input to the on-chip 8-bit analog-to-digital (A/D) converter. Typically, the accelerometer provides a signal output to the microprocessor of approximately 0.3 Vdc at -55g to 4.7 Vdc at +55g of acceleration. However, Motorola only guarantees the accuracy within $\pm 40g$ range. Using the same reference voltage for the A/D converter and accelerometer minimizes the number of additional components, but does sacrifice resolution. The resolution is defined by the following:

$$\text{count} = \frac{V_{\text{out}}}{5} \times 255$$

The count at 0g = $[2.5/5] \times 255 \approx 128$

The count at +25g = $[3.5/5] \times 255 \approx 179$

The count at -25g = $[1.5/5] \times 255 \approx 77$

Therefore the resolution 0.5g/count

The output of the accelerometer is ratiometric to the voltage applied to it. The accelerometer and the reference voltages are connected to a common supply; this yields a system that is ratiometric. By nature of this ratiometric system, variations in the voltage of the power supplied to the system will have no effect on the system accuracy.

The liquid crystal display (LCD) is directly driven from I/O ports A, B, and C on the microcontroller. The operation of a

LCD requires that the data and backplane (BP) pins must be driven by an alternating signal. This function is provided by a software routine that toggles the data and backplane at approximately a 30 Hz rate. Other than the LCD, one light emitting diode (LED) are connected to the pulse length converter (PLM) of the microcontroller. This LED will lights up for 3 seconds when an impact greater or equal to 7g is detected.

The microcontroller section of the system requires certain support hardware to allow it to function. The MC34064P-5 provides an undervoltage sense function which is used to reset the microprocessor at system power-up. The 4 MHz crystal provides the external portion of the oscillator function for clocking the microcontroller and provides a stable base for time bases functions, for instance calculation of pulse rate.

SOFTWARE DESCRIPTION

Upon power-up the system, the LCD will display CAL for approximately 4 seconds. During this period, the output of the accelerometer are sampled and averaged to obtain the zero offset voltage or zero acceleration. This value will be saved in the RAM which is used by the equation below to calculate the impact in term of g-force. One point to note is that the accelerometer should remain stationary during the zero calibration.

$$\text{Impact} = [\text{count} - \text{count}_{\text{offset}}] \times \text{resolution}$$

In this software program, the output of the accelerometer is calculated every 650 μ s. During an impact, the peak deceleration is measured and displayed on the LCD for 3 seconds before resetting it to zero. In the mean time, if a higher impact is detected, the value on the LCD will be updated accordingly.

However, when a low g is detected (e.g. 1.0g), the value will not be displayed. Instead, more samples will be taken for further averaging to eliminate the random noise and high frequency component. Due to the fact that tilting is a low g and low frequency signal, large number of sampling is preferred to avoid unstable display. Moreover, the display value is not hold for 3 seconds as in the case of an impact.

Figure 4 is a flowchart for the program that controls the system.

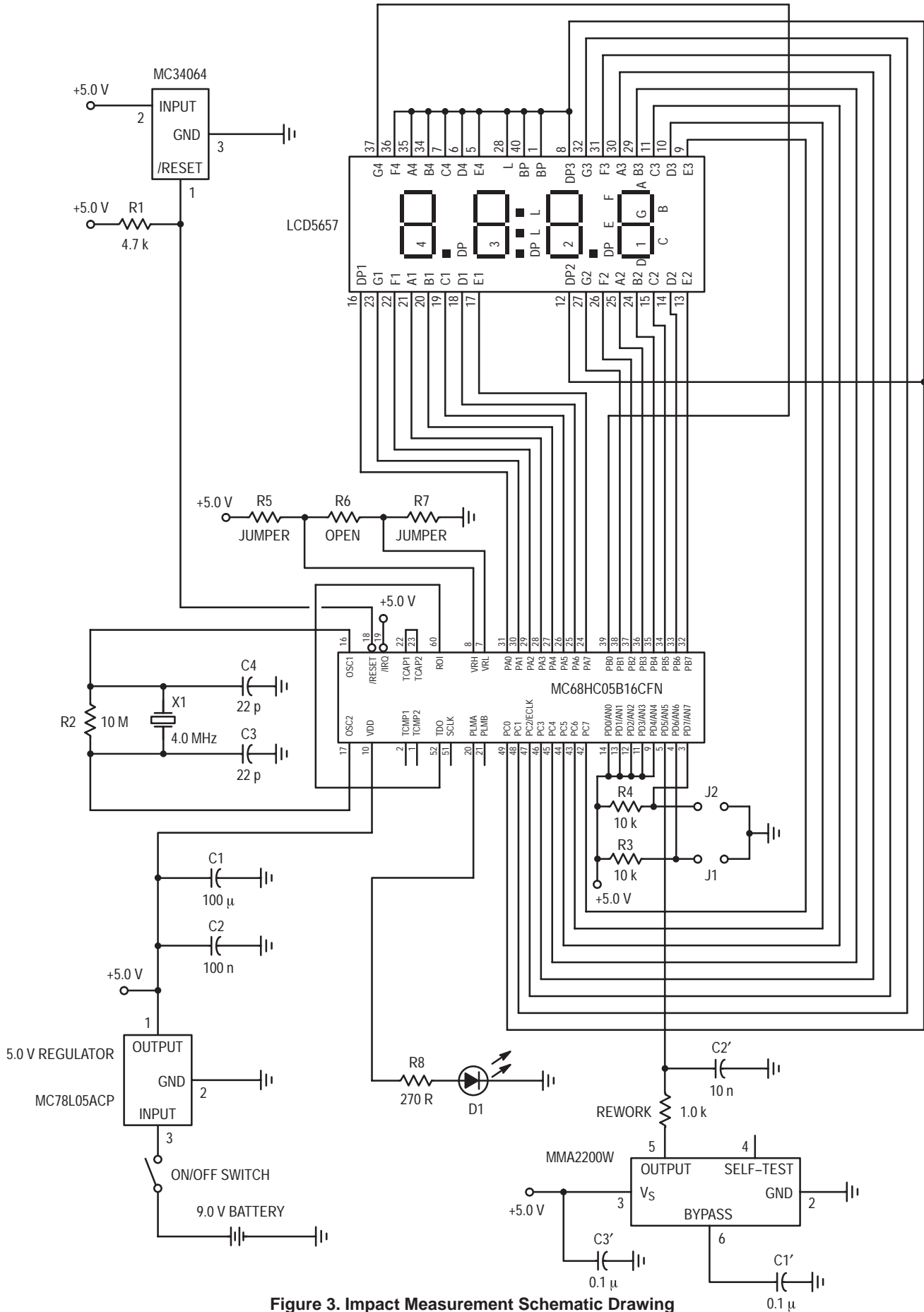

Figure 3. Impact Measurement Schematic Drawing

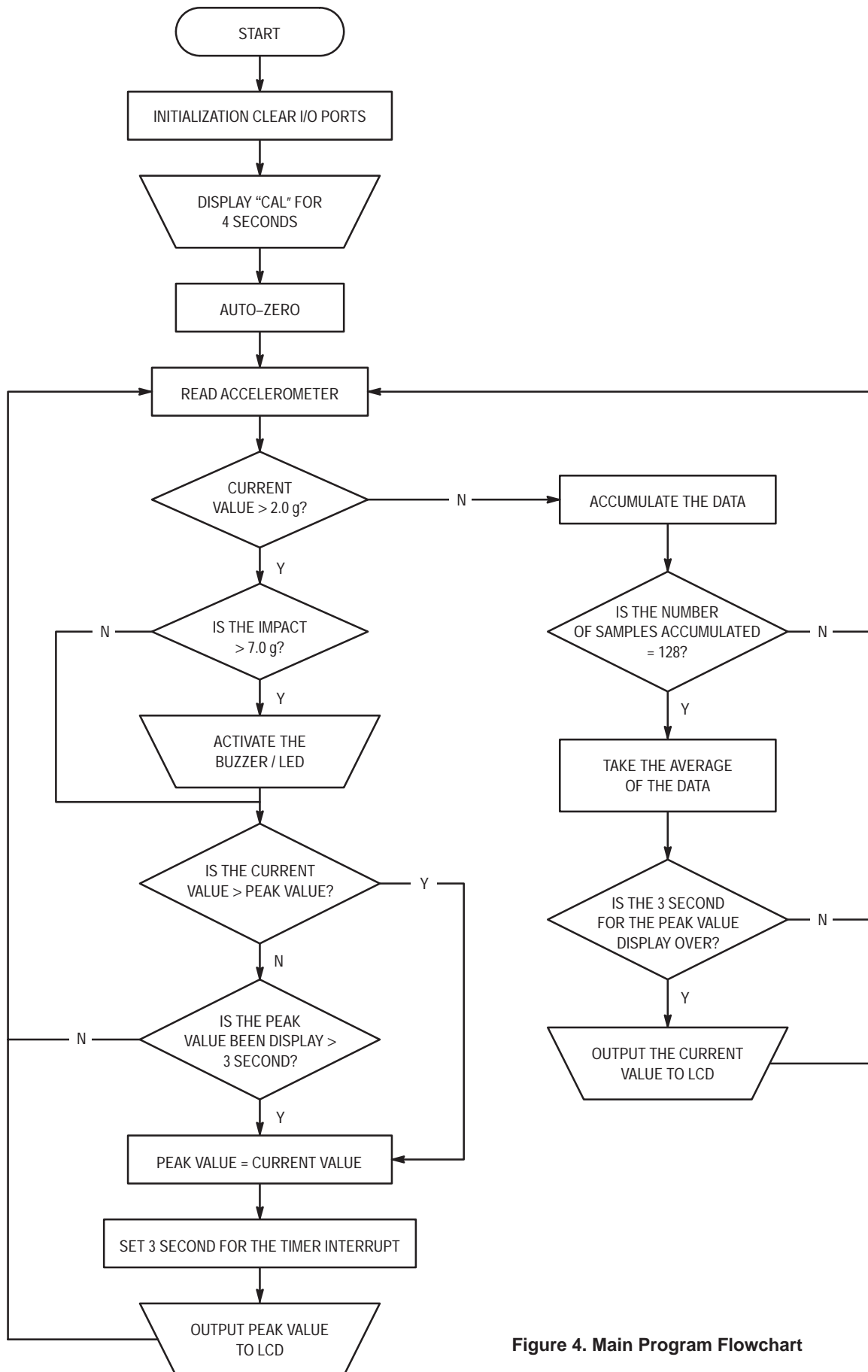

Figure 4. Main Program Flowchart

SOFTWARE SOURCE/ASSEMBLY PROGRAM CODE

```

*****
*
*           Accelerometer Demo Car Version 2.0
*
* The following code is written for MC68HC705B16 using MMDS05 software
* Version 1.01
* CASM05 - Command line assembler Version 3.04
* P & E Microcomputer Systems, Inc.
*
*           Written by : C.S. Chua
*           29 August 1996
*
*           Copyright Motorola Electronics Pte Ltd 1996
*           All rights Reserved
*
* This software is the property of Motorola Electronics Pte Ltd.
*
* Any usage or redistribution of this software without the express
* written consent of Motorola is strictly prohibited.
*
* Motorola reserves the right to make changes without notice to any
* products herein to improve reliability, function, or design. Motorola
* does not assume liability arising out of the application or use of any
* product or circuit described herein, neither does it convey license
* under its patents rights nor the rights of others. Motorola products are
* not designed, intended or authorised for use as component in systems
* intended to support or sustain life or for any other application in
* which the failure of the Motorola product could create a situation
* a situation where personal injury or death may occur. Should the buyer
* shall indemnify and hold Motorola products for any such unintended or
* unauthorised application, buyer shall indemnify and hold Motorola and
* its officers, employees, subsidiaries, affiliates, and distributors
* harmless against all claims, costs, damages, expenses and reasonable
* attorney fees arising out of, directly or indirectly, any claim of
* personal injury or death associated with such unintended or unauthorised
* use, even if such claim alleges that Motorola was negligent regarding
* the design or manufacture of the part.
*
* Motorola and the Motorola logo are registered trademarks of Motorola Inc.*
*
* Motorola Inc. is an equal opportunity/affirmative action employer.
*
*****
*****
*
*           Software Description
*
* This software is used to read the output of the accelerometer MMA2200W
* and display it to a LCD as gravity force. It ranges from -55g to +55g
* with 0g as zero acceleration or constant velocity. The resolution is
* 0.5g.
*
* The program will read from the accelerometer and hold the maximum
* deceleration value for about 3.0 seconds before resetting. At the same
* time, the buzzer/LED is activated if the impact is more than 7.0g.
* However, if the maximum deceleration changes before 3.0 seconds, it
* will update the display using the new value. Note that positive value
* implies deceleration whereas negative value implies acceleration
*
*****
*****
*
*           Initialisation
*
*****
PORTA      EQU      $00      ; Last digit
PORTB      EQU      $01      ; Second digit (and negative sign)
PORTC      EQU      $02      ; First digit (and decimal point)
ADDATA     EQU      $08      ; ADC Data
ADSTAT     EQU      $09      ; ADC Status
PLMA       EQU      $0A      ; Pulse Length Modulator (Output to Buzzer)
MISC       EQU      $0C      ; Miscellaneous Register (slow/fast mode)
TCONTROL   EQU      $12      ; Timer control register
TSTATUS    EQU      $13      ; Timer Status Register
OCMPH11    EQU      $16      ; Output Compare Register 1 High Byte

```

```

OCMPLO1 EQU $17 ; Output Compare Register 1 Low Byte
TCNTHI EQU $18 ; Timer Count Register High Byte
TCNTLO EQU $19 ; Timer Count Register Low Byte
OCMPHI2 EQU $1E ; Output Compare Register 2 High Byte
OCMPLO2 EQU $1F ; Output Compare Register 2 Low Byte
*****
* ;
* User-defined RAM ;
* ;
*****
SIGN EQU $54 ; Acceleration (-) or deceleration (+)
PRESHI2 EQU $55 ; MSB of accumulated acceleration
PRESHI EQU $56
PRESLO EQU $57 ; LSB of accumulated acceleration
PTEMPHI EQU $58 ; Acceleration High Byte (Temp storage)
PTEMPLO EQU $59 ; Acceleration Low Byte (Temp storage)
ACCHI EQU $5A ; Temp storage of acc value (High byte)
ACCLO EQU $5B ; (Low byte)
ADCOUNTER EQU $5C ; Sampling Counter
AVERAGE_H EQU $5D ; MSB of the accumulated data of low g
AVERAGE_M EQU $5E
AVERAGE_L EQU $5F ; LSB of the accumulated data of low g
SHIFT_CNT EQU $60 ; Counter for shifting the accumulated data
AVE_CNT1 EQU $61 ; Number of samples in the accumulated data
AVE_CNT2 EQU $75
TEMPCNTHI EQU $62 ; Temp storage for Timer count register
TEMPCNTLO EQU $63 ; Temp storage for Timer count register
DECHI EQU $64 ; Decimal digit high byte
DECLLO EQU $65 ; Decimal digit low byte
DCOFFSETHI EQU $66 ; DC offset of the output (high byte)
DCOFFSETLO EQU $67 ; DC offset of the output (low byte)
MAXACC EQU $68 ; Maximum acceleration
TEMPHI EQU $69
TEMPLO EQU $6A
TEMP1 EQU $6B ; Temporary location for ACC during delay
TEMP2 EQU $6C ; Temporary location for ACC during ISR
DIV_LO EQU $6D ; No of sampling (low byte)
DIV_HI EQU $6E ; No of sampling (high byte)
NO_SHIFT EQU $6F ; No of right shift to get average value
ZERO_ACC EQU $70 ; Zero acceleration in no of ADC steps
HOLD_CNT EQU $71 ; Hold time counter
HOLD_DONE EQU $72 ; Hold time up flag
START_TIME EQU $73 ; Start of count down flag
RSHIFT EQU $74 ; No of shifting required for division
ORG $300 ; ROM space 0300 to 3DFE (15,104 bytes)
DB $FC ; Display "0"
DB $30 ; Display "1"
DB $DA ; Display "2"
DB $7A ; Display "3"
DB $36 ; Display "4"
DB $6E ; Display "5"
DB $EE ; Display "6"
DB $38 ; Display "7"
DB $FE ; Display "8"
DB $7E ; Display "9"
HUNDREDHI DB $00 ; High byte of hundreds
HUNDREDLO DB $64 ; Low byte of hundreds
TENHI DB $00 ; High byte of tens
TENLO DB $0A ; Low byte of tens
*****
* ;
* Program starts here upon hard reset *
* ;
*****
RESET CLR PORTC ; Port C = 0
CLR PORTB ; Port B = 0
CLR PORTA ; Port A = 0
LDA #$FF
STA $06 ; Port C as output
STA $05 ; Port B as output
STA $04 ; Port A as output
LDA TSTATUS ; Dummy read the timer status register
CLR OCMPII2 ; so as to clear the OCF
CLR OCMPII1
LDA OCMPII2
JSR COMPRGT
CLR START_TIME

```

AN1611

```

LDA    #$40          ; Enable the output compare interrupt
STA    TCONTROL
CLI    ; Interrupt begins here
LDA    #$CC          ; Port C = 1100 1100 Letter "C"
STA    PORTC
LDA    #$BE          ; Port B = 1011 1110 Letter "A"
STA    PORTB
LDA    #$C4          ; Port A = 1100 0100 Letter "I"
STA    PORTA
LDA    #16
IDLE   JSR    DLY20    ; Idling for a while (16*0.125 = 2 sec)
DECA   ; for the zero offset to stabilize
BNE    IDLE         ; before perform auto-zero
LDA    #$00          ; Sample the data 32,768 times and take
STA    DIV_LO        ; the average 8000 H = 32,768
LDA    #$80          ; Right shift of 15 equivalent to divide
STA    DIV_HI        ; by 32,768
LDA    #!15         ; Overall sampling time = 1.033 s)
STA    NO_SHIFT
JSR    READAD       ; Zero acceleration calibration
LDX    #5           ; Calculate the zero offset
LDA    PTEMPLO      ; DC offset = PTEMPLO * 5
STA    ZERO_ACC
MUL
STA    DCOFFSETLO   ; Save the zero offset in the RAM
TXA
STA    DCOFFSETHI
CLR    HOLD_CNT
LDA    #$10         ; Sample the data 16 times and take
STA    DIV_LO        ; the average 0100 H = 16
LDA    #$00         ; Right shift of 4 equivalent to divide
STA    DIV_HI        ; by 16
LDA    #$4          ; Overall sampling time = 650 us
STA    NO_SHIFT
LDA    ZERO_ACC     ; Display 0.0g at the start
STA    MAXACC
JSR    ADTOLCD
CLR    START_TIME
CLR    AVE_CNT1
CLR    AVE_CNT2
CLR    SHIFT_CNT
CLR    AVERAGE_L
CLR    AVERAGE_M
CLR    AVERAGE_H
REPEAT JSR    READAD   ; Read acceleration from ADC
LDA    ZERO_ACC
ADD    #$04
CMP    PTEMPLO
BLO    CRASH        ; If the acceleration < 2.0g
LDA    PTEMPLO      ; Accumulate the averaged results
ADD    AVERAGE_L    ; for 128 times and take the averaging
STA    AVERAGE_L    ; again to achieve more stable
CLR    AVERAGE_L    ; reading at low g
ADC    AVERAGE_M
STA    AVERAGE_M
CLR    AVERAGE_M
ADC    AVERAGE_H
STA    AVERAGE_H
LDA    #$01
ADD    AVE_CNT1
STA    AVE_CNT1
CLR    AVE_CNT1
ADC    AVE_CNT2
STA    AVE_CNT2
CMP    #$04
BNE    REPEAT
LDA    AVE_CNT1
CMP    #$00
BNE    REPEAT
SHIFTING INC    SHIFT_CNT ; Take the average of the 128 samples
LSR    AVERAGE_H
ROR    AVERAGE_M
ROR    AVERAGE_L
LDA    SHIFT_CNT
CMP    #$0A
BLO    SHIFTING
LDA    AVERAGE_L

```



```

        STA     PTEMPLO
        LDA     HOLD_CNT      ; Check if the hold time of crash data
        CMP     #$00         ; is up
        BNE     NON-CRASH
        LDA     PTEMPLO      ; If yes, display the current acceleration
        STA     MAXACC       ; value
        JSR     ADTOLCD
        BRA     NON-CRASH
CRASH   LDA     ZERO_ACC
        ADD     #$0E         ; If the crash is more than 7g
        CMP     PTEMPLO      ; 7g = 0E H * 0.5
        BHS     NO_INFLATE
        LDA     #$FF        ; activate the LED
        STA     PLMA
NO_INFLATE JSR     MAXVALUE   ; Display the peak acceleration
        JSR     ADTOLCD
NON-CRASH CLR     SHIFT_CNT
        CLR     AVE_CNT1
        CLR     AVE_CNT2
        CLR     AVERAGE_L
        CLR     AVERAGE_M
        CLR     AVERAGE_H
        BRA     REPEAT      ; Repeat the whole process
*****
*                               *
*      Delay Subroutine         *
*      (162 * 0.7725 ms = 0.125 sec) *
*                               *
*****
DLY20   STA     TEMP1
        LDA     #!162       ; 1 unit = 0.7725 ms
OUTLP   CLRX
INNRLP  DECX
        BNE     INNRLP
        DECA
        BNE     OUTLP
        LDA     TEMP1
        RTS
*****
*                               *
*      Reading the ADC data X times *
*      and take the average       *
*      X is defined by DIV_HI and DIV_LO *
*                               *
*****
READAD  LDA     #$25
        STA     ADSTAT      ; AD status = 25H
        CLR     PRESHI2
        CLR     PRESHI      ; Clear the memory
        CLR     PRESLO
        CLRX
        CLR     ADCOUNTER
LOOP128 TXA
        CMP     #$FF
        BEQ     INC_COUNT
        BRA     CONT
INC_COUNT INC     ADCOUNTER
CONT    LDA     ADCOUNTER    ; If ADCOUNTER = X
        CMP     DIV_HI      ; Clear bit = 0
        BEQ     CHECK_X     ; Branch to END100
        BRA     ENDREAD
CHECK_X TXA
        CMP     DIV_LO
        BEQ     END128
ENDREAD BRCLR   7,ADSTAT,ENDREAD ; Halt here till AD read is finished
        LDA     ADDATA      ; Read the AD register
        ADD     PRESLO      ; PRES = PRES + ADDATA
        STA     PRESLO
        CLRA
        ADC     PRESHI
        STA     PRESHI
        CLRA
        ADC     PRESHI2
        STA     PRESHI2
        INCX                ; Increase the AD counter by 1
        BRA     LOOP128     ; Branch to Loop128
END128 CLR     RSHIFT      ; Reset the right shift counter

```

AN1611

```

DIVIDE      INC      RSHIFT          ; Increase the right counter
            LSR      PRESHI2
            ROR      PRESHI          ; Right shift the high byte
            ROR      PRESLO          ; Right shift the low byte
            LDA      RSHIFT
            CMP      NO_SHIFT        ; If the right shift counter >= NO_SHIFT
            BHS      ENDDIVIDE      ; End the shifting
            JMP      DIVIDE          ; otherwise continue the shifting
ENDDIVIDE   LDA      PRESLO
            STA      PTEMPLO
            RTS

*****
*
*      Timer service interrupt
*      Alternates the Port data and
*      backplane of LCD
*
*****
TIMERCOMP   STA      TEMP2           ; Push Accumulator
            COM      PORTC          ; Port C = - (Port C)
            COM      PORTB          ; Port B = - (Port B)
            COM      PORTA          ; Port A = - (Port A)
            LDA      START_TIME     ; Start to count down the hold time
            CMP      #$FF           ; if START_TIME = FF
            BNE      SKIP_TIME
            JSR      CHECK_HOLD
SKIP_TIME   BSR      COMPRGT        ; Branch to subroutine compare register
            LDA      TEMP2          ; Pop Accumulator
            RTI

*****
*
*      Check whether the hold time
*      of crash impact is due
*
*****
CHECK_HOLD  DEC      HOLD_CNT
            LDA      HOLD_CNT
            CMP      #$00           ; Is the hold time up?
            BNE      NOT_YET
            LDA      #$00           ; If yes,
            STA      PLMA           ; stop buzzer
            LDA      #$FF           ; Set HOLD_DONE to FF indicate that the
            STA      HOLD_DONE      ; hold time is up
            CLR      START_TIME     ; Stop the counting down of hold time
NOT_YET     RTS

*****
*
*      Subroutine reset
*      the timer compare register
*
*****
COMPRGT     LDA      TCNTHI         ; Read Timer count register
            STA      TEMPTCNTHI     ; and store it in the RAM
            LDA      TCNTLO
            STA      TEMPTCNTLO
            ADD      #$4C           ; Add 1D4C H = 7500 periods
            STA      TEMPTCNTLO     ; with the current timer count
            LDA      TEMPTCNTHI     ; 1 period = 2 us
            ADC      #$1D
            STA      TEMPTCNTHI     ; Save the next count to the register
            STA      OCMPHI1
            LDA      TSTATUS        ; Clear the output compare flag
            LDA      TEMPTCNTLO     ; by access the timer status register
            STA      OCMPL01        ; and then access the output compare
            RTS                     ; register

*****
*
*      Determine which is the next
*      acceleration value to be display
*
*****
MAXVALUE    LDA      PTEMPLO
            CMP      MAXACC         ; Compare the current acceleration with
            BLS      OLDMAX         ; the memory, branch if it is <= maxacc
            BRA      NEWMAX1
OLDMAX      LDA      HOLD_DONE      ; Decrease the Holdtime when
            CMP      #$FF           ; the maximum value remain unchanged

```

```

        BEQ     NEWMAX1      ; Branch if the Holdtime is due
        LDA     MAXACC       ; otherwise use the current value
        BRA     NEWMAX2
NEWMAX1  LDA     #$C8        ; Hold time = 200 * 15 ms = 3 sec
        STA     HOLD_CNT    ; Reload the hold time for the next
        CLR     HOLD_DONE   ; maximum value
        LDA     #$FF
        STA     START_TIME  ; Start to count down the hold time
        LDA     PTEMPLO     ; Take the current value as maximum
NEWMAX2  STA     MAXACC
        RTS

*****
*
*   This subroutine is to convert
*   the AD data to the LCD
*   Save the data to be diplayed
*   in MAXACC
*
*****
ADTOLCD  SEI             ; Disable the Timer Interrupt !!
        LDA     #$00       ; Load 0000 into the memory
        STA     DECHI
        LDA     #$00
        STA     DECLO
        LDA     MAXACC
        LDX     #5
        MUL             ; Acceleration = AD x 5
        ADD     DECLO     ; Acceleration is stored as DECHI
        STA     DECLO     ; and DECLO
        STA     ACCLO     ; Temporary storage
        LDA     #$00     ; Assume positive deceleration
        STA     SIGN     ; "00" positive ; "01" negative
        CLRA
        TXA
        ADC     DECHI
        STA     DECHI
        STA     ACCHI     ; Temporary storage
        LDA     DECLO
        SUB     DCOFFSETLO ; Deceleration = Dec - DC offset
        STA     DECLO
        LDA     DECHI
        SBC     DCOFFSETHI
        STA     DECHI
        BCS     NEGATIVE  ; Branch if the result is negative
        BRA     SEARCH
NEGATIVE  LDA     DCOFFSETLO ; Acceleration = DC offset - Dec
        SUB     ACCLO
        STA     DECLO
        LDA     DCOFFSETHI
        SBC     ACCHI
        STA     DECHI
        LDA     #$01     ; Assign a negative sign
        STA     SIGN
SEARCH   CLRX             ; Start the search for hundred digit
LOOP100  LDA     DECLO     ; Acceleration = Acceleration - 100
        SUB     HUNDREDLO
        STA     DECLO
        LDA     DECHI
        SBC     HUNDREDHI
        STA     DECHI
        INCX             ; X = X + 1
        BCC     LOOP100  ; if acceleration >= 100, continue the
        DECX             ; loop100, otherwise X = X - 1
        LDA     DECLO     ; Acceleration = Acceleration + 100
        ADD     HUNDREDLO
        STA     DECLO
        LDA     DECHI
        ADC     HUNDREDHI
        STA     DECHI
        TXA             ; Check if the MSD is zero
        AND     #$FF
        BEQ     NOZERO    ; If MSD is zero, branch to NOZERO
        LDA     $0300,X   ; Output the first second digit
        STA     PORTC
        BRA     STARTTEN
NOZERO   LDA     #$00     ; Display blank if MSD is zero
        STA     PORTC

```

AN1611

```
STARTTEN    CLRX                ; Start to search for ten digit
LOOP10     LDA    DECLO          ; acceleration = acceleration - 10
          SUB    TENLO
          STA    DECLO
          LDA    DECHI
          SBC    TENHI
          STA    DECHI
          INCX
          BCC    LOOP10         ; if acceleration >= 10 continue the
          DECF                ; loop, otherwise end
          LDA    DECLO          ; acceleration = acceleration + 10
          ADD    TENLO
          STA    DECLO
          LDA    DECHI
          ADC    TENHI
          STA    DECHI
          LDA    $0300,X        ; Output the last second digit
          EOR    SIGN          ; Display the sign
          STA    PORTB
          CLRX                ; Start to search for the last digit
          LDA    DECLO          ; declo = declo - 1
          TAX
          LDA    $0300,X        ; Output the last digit
          EOR    #$01          ; Add a decimal point in the display
          STA    PORTA
          CLI                  ; Enable Interrupt again !
          RTS

*****
*
*   This subroutine provides services   *
*   for those unintended interrupts   *
*
*****
SWI        RTI                ; Software interrupt return
IRQ        RTI                ; Hardware interrupt
TIMERCAP   RTI                ; Timer input capture
TIMERROV   RTI                ; Timer overflow
SCI        RTI                ; Serial communication Interface
          ; Interrupt
          ORG    $3FF2        ; For 68HC05B16, the vector location
          FDB    SCI          ; starts at 3FF2
          FDB    TIMERROV     ; For 68HC05B5, the address starts
          FDB    TIMERCMP     ; 1FF2
          FDB    TIMERCAP
          FDB    IRQ
          FDB    SWI
          FDB    RESET
```

NOTES

NOTES

NOTES

Mfax is a trademark of Motorola, Inc.

Motorola reserves the right to make changes without further notice to any products herein. Motorola makes no warranty, representation or guarantee regarding the suitability of its products for any particular purpose, nor does Motorola assume any liability arising out of the application or use of any product or circuit, and specifically disclaims any and all liability, including without limitation consequential or incidental damages. "Typical" parameters which may be provided in Motorola data sheets and/or specifications can and do vary in different applications and actual performance may vary over time. All operating parameters, including "Typicals" must be validated for each customer application by customer's technical experts. Motorola does not convey any license under its patent rights nor the rights of others. Motorola products are not designed, intended, or authorized for use as components in systems intended for surgical implant into the body, or other applications intended to support or sustain life, or for any other application in which the failure of the Motorola product could create a situation where personal injury or death may occur. Should Buyer purchase or use Motorola products for any such unintended or unauthorized application, Buyer shall indemnify and hold Motorola and its officers, employees, subsidiaries, affiliates, and distributors harmless against all claims, costs, damages, and expenses, and reasonable attorney fees arising out of, directly or indirectly, any claim of personal injury or death associated with such unintended or unauthorized use, even if such claim alleges that Motorola was negligent regarding the design or manufacture of the part. Motorola and  are registered trademarks of Motorola, Inc. Motorola, Inc. is an Equal Opportunity/Affirmative Action Employer.

How to reach us:

USA/EUROPE/Locations Not Listed: Motorola Literature Distribution; P.O. Box 5405, Denver, Colorado 80217.
1-303-675-2140 or 1-800-441-2447

JAPAN: Motorola Japan Ltd.; SPS, Technical Information Center, 3-20-1, Minami-Azabu, Minato-ku, Tokyo 106-8573 Japan.
81-3-3440-3569

ASIA/PACIFIC: Motorola Semiconductors H.K. Ltd.; Silicon Harbour Centre, 2 Dai King Street, Tai Po Industrial Estate, Tai Po, N.T., Hong Kong. 852-26668334

Customer Focus Center: 1-800-521-6274

Mfax™: RMFAX0@email.sps.mot.com – TOUCHTONE 1-602-244-6609
Motorola Fax Back System – US & Canada ONLY 1-800-774-1848
– http://sps.motorola.com/mfax/

HOME PAGE: <http://motorola.com/sps/>

