

ASB205 — MPX5000 Series Sensor Module

Prepared by: Bill Lucas and Warren Schultz

A plug-in module that is part of a systems development tool set for pressure sensors is presented here. It provides an analog signal from an MPX5000 series sensor to a Motorola Sensor Development Controller, or can be used stand alone to provide power and signal connections to the sensor.

PLUG-IN MODULE DESCRIPTION

A summary of information for using systems development plug-in module ASB205 includes the schematic in Figure 2, connector pinout in Figure 3, a pin by pin description of functionality, specs in Tables 1–3, and a parts list in Table 4. Figure 4 in the Applications section provides a quick reference for making connections. A discussion of the design appears under the heading Design Considerations.

Function

The plug-in module shown in Figure 1 is designed to supply pressure and temperature inputs to a sensor development controller. The sensor output is filtered and buffered with a unity gain rail to rail amplifier. If desired, jumpers on the board allow direct connection of the sensor output to the controller. Connections are made through a DB-9 connector, which allows this board to be plugged directly into its controller. If physical separation is desired, a standard 9 wire straight-through serial cable can be inserted between the two boards. Alternately, connections for 5 volts, ground, and the output signal can be made through screw terminals at the top of the board. A socket for sensor connections makes changing from one pressure range to another relatively easy.

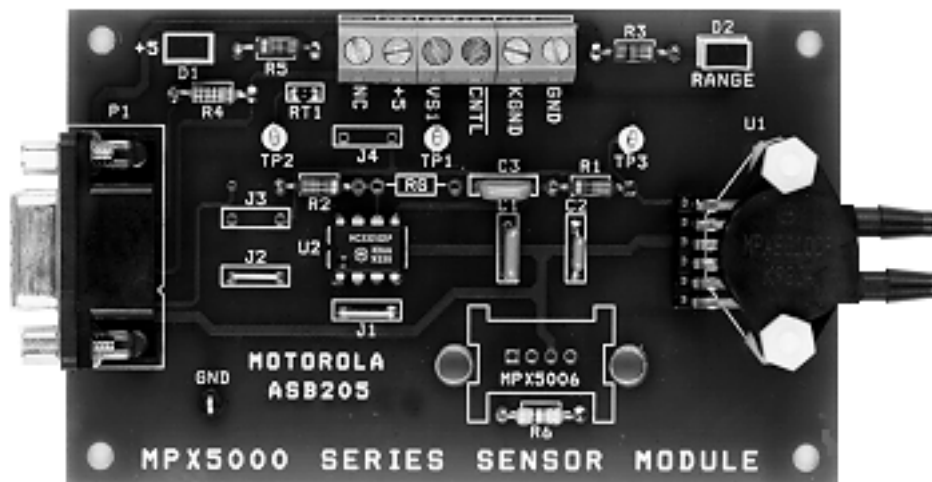

Figure 1. ASB205 — MPX5000 Series Sensor Module

AN1653

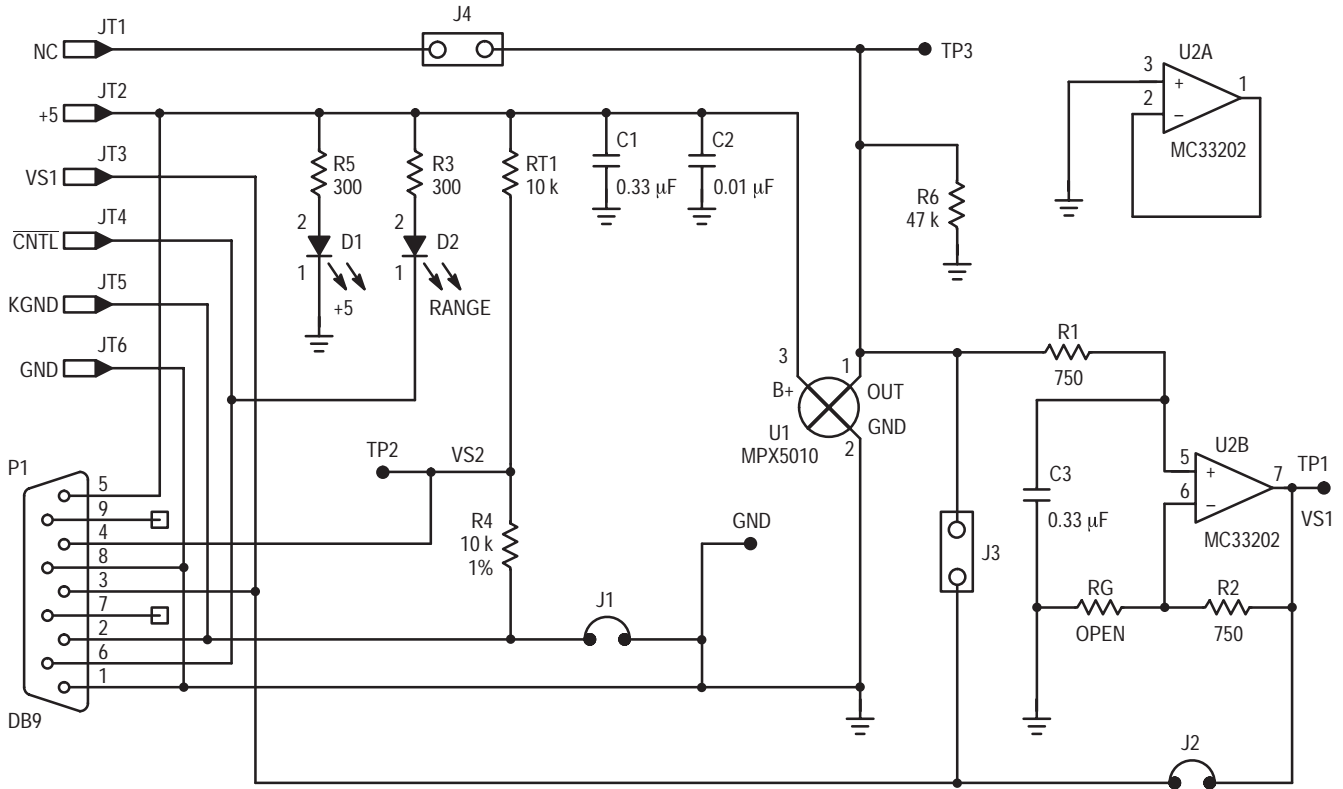

Figure 2. Schematic

Electrical Characteristics

The electrical characteristics in Tables 1, 2, & 3, apply to operation at 25 degrees Celsius, and unless otherwise

specified a +5 volt input of 5.00 volts. The values in Tables 2 and 3 are nominal values.

Table 1. Electrical Characteristics

Characteristic	Symbol	Min	Typ	Max	Units
DC Supply Voltage	+5	4.75	5.0	5.25	Volts
Pressure Sensor Output Voltage	VS1	—	—	—	mV
— Zero Pressure	—	—	200	—	mV
— Full Scale	—	—	4.7	—	Volts
Temp Sensor Output Voltage	VS2	—	2.5	—	Volts
Quiescent Current	I _{CC}	—	25	—	mA

Table 2. Output Characteristics (VS1)

Sensor	Full Scale Pressure (kPa)	Sensitivity (mV/kPa)	Zero Pressure Offset (Volts)	Full Scale Output Voltage (Volts)	Full Scale Span (Volts)
MPX5006*	6	750	.2	4.7	4.5
MPX5010*	10	450	.2	4.7	4.5
MPX5050	50	90	.2	4.7	4.5
MPX5100*	100	45	.2	4.7	4.5
MPX5700*	700	6.43	.2	4.7	4.5
MPX5999	1000	4.5	.2	4.7	4.5

*Included with ASB205 kit

Table 3. VS2 Versus Temperature

Temperature °C	R _T Ohms	VS2 Volts	Temperature °C	R _T Ohms	VS2 Volts
0	32773	1.17	40	5323	3.26
5	25456	1.41	45	4365	3.48
10	19932	1.67	50	3599	3.68
15	15725	1.94	55	2983	3.85
20	12497	2.22	60	2486	4.00
25	10000	2.50	65	2082	4.14
30	8055	2.77	70	1753	4.25
35	6528	3.03	75	1482	4.35

Content

Board contents are described by the following parts list and the schematic in Figure 2. A pin by pin circuit description follows in the next section.

Table 4. Parts List

Item	Quantity	Reference	Part
1	2	C1,C3	.33 μ F Ceramic
2	1	C2	.01 μ F Ceramic
3	2	D1	LED (RED)
4	1	D2	LED (RED)
5	4	TP1,TP2,TP3,GND	Test Point
6	6	JT1–JT6	Screw Terminal
7	2	J1,J2	Jumper–Wire
8	1	P1	DB9 Connector
9	2	RT1	10K Thermistor
10	1	R4	10K 1%
11	2	R2,R1	750
12	2	R5,R3	300
13	1	R6	47K
14	1	U1	MPX5010
15	1	U2	MC33202

Pin by Pin Description

Inputs and outputs are grouped into two connectors. A DB–9 connector provides a plug–in feature. If this connector is used, no other connections are necessary. Alternately,

power, ground, and sensor output connections can be made through screw terminals at the top of the board. The screw terminals and the DB–9 are wired in parallel. DB–9 connector pinouts are shown in Figure 3.

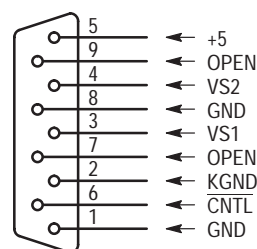

Figure 3. DB–9 Pinout

DB–9 Connector

+5:

5 volt power is supplied through pin 5 on the DB–9 connector.

GND:

The ground connection is on pin one. It connects the sensor's analog ground to the controller's digital ground.

KGND:

An additional ground connection, labeled KGND, is made on pin 2. As shipped, KGND is tied to GND via jumper J1. If J1 is opened, KGND provides a separate return for the temperature sensor. This feature can be helpful if a cable is used between the sensor module and its controller.

AN1653

VS1:

The pressure sensor output signal, VS1, is on pin 3. This is the sensor's output, filtered and then buffered with a unity gain amplifier. If direct connection to the sensor's output is preferred, it will appear on this pin when Jumper J2 is open, and a wire is soldered into Jumper J3.

VS2:

A temperature dependent output signal is supplied on pin 4. It is supplied from a thermistor that has a nominal output voltage of 2.5 volts at 25 degrees C. This thermistor sees a temperature rise due to power dissipation on the board, and typically reads several degrees higher than ambient in still air.

CNTL:

A control signal is supplied on pin 6. It is normally high, and switches low to light the RANGE light when the sensor's full scale pressure is exceeded. With code modifications, the pressure at which this transition occurs can be changed, and the signal used to control an external device.

Board Code:

A board code that lets the controller know that this is an MPX5000 series module is supplied with a ground on pin 8 and an open on pin 7.

Pin 9:

There is no connection made to Pin 9 on this board. However, power supply voltage B+ will be present on this pin when plugged into a Motorola Sensor Development Controller.

Screw Terminals

Connections for +5, VS1, CNTL, \overline{KGND} , & GND are wired in parallel with the DB-9 connector. As shipped, KGND and GND are tied together with Jumper J1. A no connect terminal labeled, NC, is tied to Jumper J4 which is open. If a wire is placed in J4, this terminal is then connected to the sensor output.

Test Points TP1–TP3, & GND

Test points TP1, TP2, & TP3 provide access to output signals. TP1 is connected to the filtered and buffered pressure sensor output signal. TP2 is connected to the thermistor output signal, and TP3 is connected to sensor's output. A test point for ground is also provided.

Indicator Lights

+5:

The +5 light is provided to indicate the presence of 5 volt power.

RANGE:

The RANGE indicator light turns on when the sensor's full scale pressure range is exceeded.

APPLICATION EXAMPLE

An application example shown in Figure 4 illustrates system connections to an ASB200 control board and a pressure source. This arrangement can be run stand alone, or the ASB200 can be connected to an MMDS or MMEVS system for code development. The two boards are designed such that the DB-9 connectors plug into each other. Once they are plugged in it is only a matter of connecting a power supply and a pressure source to get a system up and running. If physical separation between the sensor location and the controller is desired, a standard 9 wire straight-through serial cable can be used between the two boards.

Measuring different pressure ranges is facilitated by using a socket for the sensor that is supplied on the board. Pads for an MPX5006 are also provided. To use the MPX5006, it is necessary to have the 6 pin socket empty, snap in the MPX5006, and then solder its leads to the pads that are provided. The correct orientation is with its marking facing the front of the board.

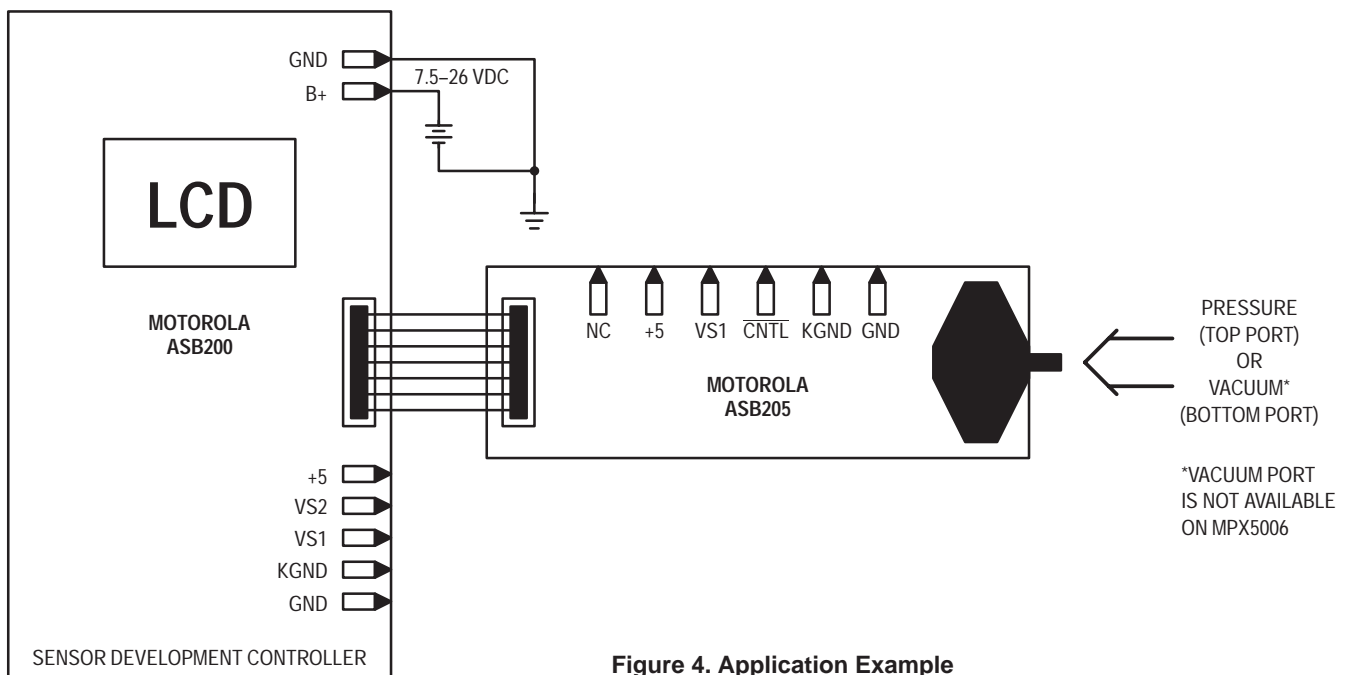

Figure 4. Application Example

DESIGN CONSIDERATIONS

MPX5000 sensors are plug and play devices in most applications, particularly when connected to a micro-controller with an 8 bit A/D converter. Although micro's with 8-bit A/D's are most common, higher resolution A/D's, such as the one on the 68HC705JP7 in this tool set, are becoming increasingly popular. With these higher resolution A/D's, the noise that is inherent to piezo-resistive bridges becomes a design consideration. For that reason, the sensor's output is filtered with a single pole filter, and then buffered with a unity gain buffer. An MC33202 rail to rail operational amplifier was chosen for its ability to drive cable

capacitance, in the event that a cable is used between the plug-in module and controller. For applications where the sensor and micro-controller are on the same board, an MC33502 is a better choice, due to its lower offset voltage.

CONCLUSION

The ASB205 plug-in module is part of a systems development tool set for pressure sensors. It provides pressure and temperature input signals to a Motorola Sensor Development Controller, or can be used stand alone to provide power and signal connections to MPX5000 series sensors.

NOTES

NOTES

Motorola reserves the right to make changes without further notice to any products herein. Motorola makes no warranty, representation or guarantee regarding the suitability of its products for any particular purpose, nor does Motorola assume any liability arising out of the application or use of any product or circuit, and specifically disclaims any and all liability, including without limitation consequential or incidental damages. "Typical" parameters which may be provided in Motorola data sheets and/or specifications can and do vary in different applications and actual performance may vary over time. All operating parameters, including "Typicals" must be validated for each customer application by customer's technical experts. Motorola does not convey any license under its patent rights nor the rights of others. Motorola products are not designed, intended, or authorized for use as components in systems intended for surgical implant into the body, or other applications intended to support or sustain life, or for any other application in which the failure of the Motorola product could create a situation where personal injury or death may occur. Should Buyer purchase or use Motorola products for any such unintended or unauthorized application, Buyer shall indemnify and hold Motorola and its officers, employees, subsidiaries, affiliates, and distributors harmless against all claims, costs, damages, and expenses, and reasonable attorney fees arising out of, directly or indirectly, any claim of personal injury or death associated with such unintended or unauthorized use, even if such claim alleges that Motorola was negligent regarding the design or manufacture of the part. Motorola and  are registered trademarks of Motorola, Inc. Motorola, Inc. is an Equal Opportunity/Affirmative Action Employer.

Mfax is a trademark of Motorola, Inc.

How to reach us:

USA/EUROPE/Locations Not Listed: Motorola Literature Distribution;
P.O. Box 5405, Denver, Colorado 80217. 1-303-675-2140 or 1-800-441-2447

JAPAN: Nippon Motorola Ltd.; SPD, Strategic Planning Office, 141,
4-32-1 Nishi-Gotanda, Shinagawa-ku, Tokyo, Japan. 81-3-5487-8488

Customer Focus Center: 1-800-521-6274

Mfax™: RMFAX0@email.sps.mot.com – TOUCHTONE 1-602-244-6609
Motorola Fax Back System – US & Canada ONLY 1-800-774-1848
– http://sps.motorola.com/mfax/

ASIA/PACIFIC: Motorola Semiconductors H.K. Ltd.; 8B Tai Ping Industrial Park,
51 Ting Kok Road, Tai Po, N.T., Hong Kong. 852-26629298

HOME PAGE: <http://motorola.com/sps/>



MOTOROLA

