

M68EML08GP32

EMULATION MODULE
USER'S MANUAL

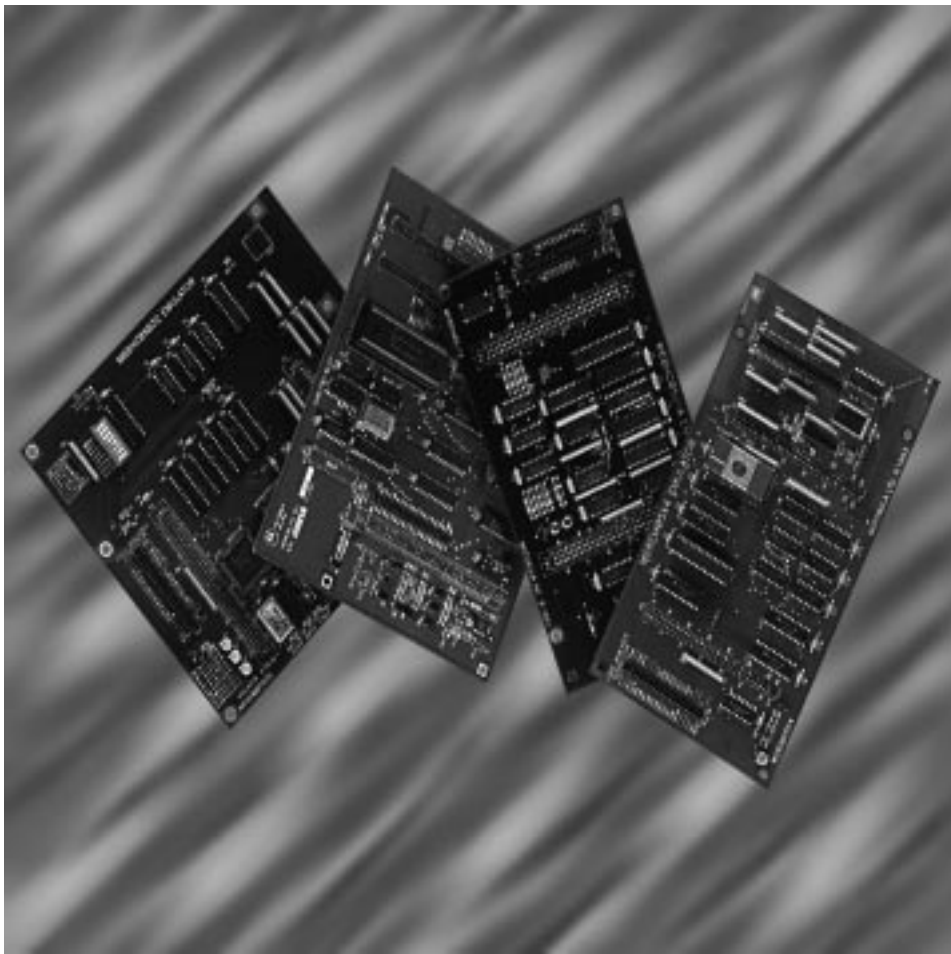

MOTOROLA

Motorola reserves the right to make changes without further notice to any products herein to improve reliability, function or design. Motorola does not assume any liability arising out of the application or use of any product or circuit described herein; neither does it convey any license under its patent rights nor the rights of others. Motorola products are not designed, intended, or authorized for use as components in systems intended for surgical implant into the body, or other applications intended to support or sustain life, or for any other application in which the failure of the Motorola product could create a situation where personal injury or death may occur. Should Buyer purchase or use Motorola products for any such unintended or unauthorized application, Buyer shall indemnify and hold Motorola and its officers, employees, subsidiaries, affiliates, and distributors harmless against all claims, costs, damages, and expenses, and reasonable attorney fees arising out of, directly or indirectly, any claim of personal injury or death associated with such unintended or unauthorized use, even if such claim alleges that Motorola was negligent regarding the design or manufacture of the part.

List of Sections

Section 1. General Description	9
Section 2. Configuration and Operation	15
Section 3. Connector Information	21
Section 4. Schematics	31
Index	49

List of Sections

Table of Contents

Section 1. General Description

1.1	Contents	9
1.2	Introduction.....	9
1.3	Development Systems.....	10
1.3.1	Motorola Modular Development System (MMDS).....	10
1.3.2	Motorola Modular Evaluation System (MMEVS).....	11
1.4	EM Layout	12
1.5	Specifications	13

Section 2. Configuration and Operation

2.1	Contents	15
2.2	Introduction.....	15
2.3	System Limitations	16
2.4	Setting Jumper Headers	16
2.4.1	Clock Source Header (P3)	17
2.4.2	Factory Test Select Header (P5)	18
2.4.3	Factory Test Select Header (P8)	18
2.5	Remaining System Installation.....	19

Section 3. Connector Information

3.1	Contents	21
3.2	Introduction.....	21
3.3	Logic Analyzer Connector (P1)	22
3.4	Target Connectors (P6 and P7).....	25
3.5	Target Cable Assembly.....	30

Section 4. Schematics

Index

Table of Contents

List of Figures and Tables

Figure	Title	Page
1-1	M68EML08GP32 Emulator Module	12
2-1	Jumper Header P3	17
2-2	Jumper Header P5	18
2-3	Jumper Header P8	18
3-1	Logic Analyzer Connector P1 Pin Assignments	22
3-2	Target Connectors P6 and P7 Pin Assignments	25
3-3	Target Cable Assembly	30

Table	Title	Page
1-1	M68EML08GP32 Specifications	13
2-1	Jumper Headers	16
3-1	Logic Analyzer Connector P1 Signal Descriptions	23
3-2	Target Connectors P6 Signal Descriptions	26
3-3	Target Connectors P7 Signal Descriptions	28

List of Fiqes and Tables

Section 1. General Description

1.1 Contents

1.2	Introduction.	9
1.3	Development Systems.	10
1.3.1	Motorola Modular Development System (MMDS).	10
1.3.2	Motorola Modular Evaluation System (MMEVS).	11
1.4	EM Layout	12
1.5	Specifications	13

1.2 Introduction

This user's manual explains connection, configuration, and operation information specific to the M68EML08GP32 emulator module (GP32EM). The GP32EM allows emulations and debugging of target systems based on these microcontroller units (MCUs):

- MC68HC908GP20 (GP20)
- MC68HC908GP32 (GP32)
- MC68HC908JL3 (JL3)

The GP32EM is a low-voltage emulator operating in the range +2.0 to +5.0 Vdc.

This section describes Motorola's two development systems that use the GP32EM, and it explains the GP32EM's layout.

1.3 Development Systems

The GP32EM can be part of two Motorola development systems:

- M68MMDS0508 modular development system (MMDS)
- M68MMEVS0508 evaluation system (MMEVS)

1.3.1 Motorola Modular Development System (MMDS)

The MMDS is an emulator system that provides a bus state analyzer and real-time memory windows. The unit's integrated design environment includes an editor, an assembler, user interface, and source-level debugger.

A complete MMDS consists of:

- Station module — The metal MMDS enclosure containing the control board and the internal power supply
- Emulator module (EM) — A separately purchased printed circuit board that enables system functionality for a specific set of MCUs
- Two logic clip cable assemblies — Twisted-pair cables that connect the station module to the target system, a test fixture, a clock, an oscillator, or any other circuitry useful for evaluation or analysis. One end of each cable assembly has a molded connector, which fits into station-module pod A or pod B. Leads at the other end of each cable terminate in female probe tips. Ball clips come with the cable assemblies.
- 9-lead RS-232 serial cable — Cable that connects the station module to the host computer RS-232 port
- 9- to 25-pin adapter — A molded assembly that connects the 9-pin cable to a 25-pin serial port
- System software — Software on 3-1/2 inch diskettes
- MMDS documentation — *MMDS Operations Manual*, Motorola document order number MMDS0508OM/D; a system software manual, included with the P&E Microcomputer System, Inc.'s MMDS0508 software package; and the appropriate emulator user's manual

MMDS baud rates are selected by the user at 2400, 4800, 9600, 19,200, 38,400, or 57,600.

As mentioned, the GP32EM gives the MMDS the ability to emulate target systems based on MC68HC908GP20, MC68HC908GP32, and MC68HC908JL3 MCUs. By substituting a different EM, MMDS can be enabled to emulate target systems based on a different MCU. (A local Motorola representative can explain all the EMs available.)

1.3.2 Motorola Modular Evaluation System (MMEVS)

An MMEVS is an economical, two-board tool for designing, debugging, and evaluating target systems based on MC68HC05 or MC68HC08 MCUs.

A complete MMEVS consists of:

- Platform board (PFB) — The bottom board, which supports the emulator module; has connectors for power and for a terminal or host computer
- Emulator module (EM) — A separately purchased printed circuit board that enables system functionality for a specific set of MCUs; fits onto the PFB
- RS-232 serial cable — A separately purchased cable that connects the PFB to the host computer RS-232 port
- System software — Software on 3-1/2 inch diskettes
- MMEVS documentation — *MMEVS Operations Manual*, Motorola document order number MMEVSOM/D, and the appropriate emulator user's manual

An MMEVS features automatic selection of the communication baud rate from these choices: 2400, 4800, 9600, 19,200, 38,400, or 57,600.

With a GP32EM, the MMEVS emulates target systems based on MC68HC908GP20, MC68HC908GP32, and MC68HC908JL3 MCUs. By substituting a different EM, the MMEVS can be enabled to emulate target systems based on a different MCU. (A local Motorola representative can explain all the EMs available.)

Section 2. Configuration and Operation explains how to configure and use the GP32EM as part of an MMDS or MMEVS system.

1.4 EM Layout

Figure 1-1 shows the layout of the GP32EM.

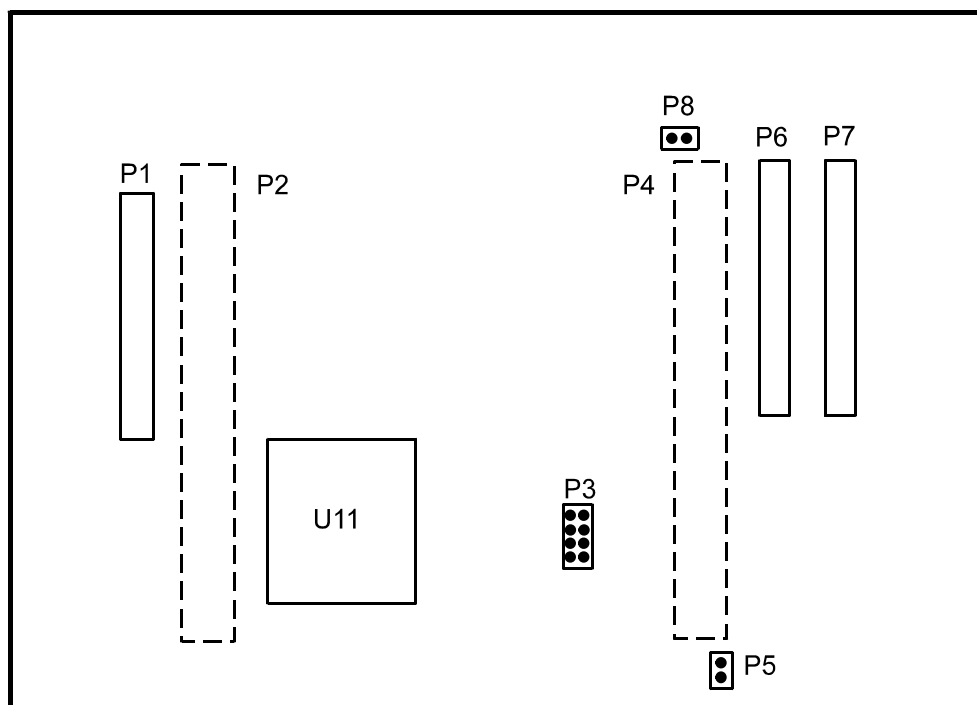

Figure 1-1. M68EML08GP32 Emulator Module

The main elements of the GP32EM are:

- Connector P1 — Permits connection to a logic analyzer
- DIN connectors P2 and P4 — Connect the EM to the MMDS control board or the MMEVS platform board
- Jumper header P3 — Selects the MCU clock source
- Connector P5 — For factory use only
- Connectors P6 and P7 — Customer-specific interfaces to the target system
- Connector P8 — To connect a 20-k Ω pullup resistor between V_{DDAD} to V_{DD}

The GP32EM requires these user-supplied cables for connection to other components of a development system:

- An 80-lead target cable and target head adapter to connect the target system to connectors P6 and P7

1.5 Specifications

Table 1-1 lists GP32EM specifications.

Table 1-1. M68EML08GP32 Specifications

Characteristics	Specifications
MCU extension I/O ports	HCMOS compatible
Operating temperature	0° to +40°C
Storage temperature	–40° to +85°C
Relative humidity	0 to 90%, non-condensing
Power requirements	+5 Vdc and +12 Vdc (charge pump), provided from the MMDS control board or MMEVS platform board
Dimensions	8 x 6.5 inches; 230 x 165 mm
Weight	10.4 ounces; 295 g

Section 2. Configuration and Operation

2.1 Contents

2.2	Introduction	15
2.3	System Limitations	16
2.4	Setting Jumper Headers	16
2.4.1	Clock Source Header (P3)	17
2.4.2	Factory Test Select Header (P5)	18
2.4.3	Factory Test Select Header (P8)	18
2.5	Remaining System Installation	19

2.2 Introduction

This section explains configuration and operation of the M68EML08GP32 (GP32EM) when it is installed in an MMDS (Motorola modular development system) or MMEVS (Motorola modular evaluation system). For other parts of system installation or configuration, see the MMDS or MMEVS hardware manuals.

NOTE: *A GP32EM already installed in an MMDS station module can be reconfigured. To do so, switch off station-module power, then follow the guidance in this section. Similarly, GP32EM that is already installed on the MMEVS platform board can be reconfigured, provided that platform-board power is disconnected.*

CAUTION: *Be sure to switch off or disconnect power when reconfiguring an installed EM. Reconfiguring EM jumper headers with the power on can damage system circuits.*

ESD CAUTION: Ordinary amounts of static electricity from clothing or the work environment can damage or degrade electronic devices and equipment. For example, the electronic components installed on printed circuit boards are extremely sensitive to electrostatic discharge (ESD). Wear a ground wrist strap whenever handling any printed circuit board. This strap provides a conductive path for safely discharging static electricity to ground.

2.3 System Limitations

To use the ADC (analog-to-digital converter) when emulating JL3, bit 4 of ADICLK at address \$3E must be set. It is cleared out of reset. Otherwise, the ADC will run on a clock four times faster.

2.4 Setting Jumper Headers

The GP32EM has two jumper headers. **Table 2-1** contains a summary of settings for these headers. **2.4.1 Clock Source Header (P3)** and **2.4.2 Factory Test Select Header (P5)** give additional information about each jumper header.

Table 2-1. Jumper Headers



Jumper Header	Type	Description
P3		<p>Jumper between pins 1 and 2; selects an external clock source for the MCU EXTAL input signal from target head connectors</p> <p>Jumper between pins 3 and 4; selects the onboard 32.768-kHz crystal oscillator</p> <p>Jumper between pins 5 and 6 (factory default); selects the clock signal from the MMDS control board or MMEVS platform board</p> <p>Jumper between pins 7 and 8; selects an on-board 32 MHz clock signal</p>
P5		<p>Factory use only; should be left open</p>

Table 2-1. Jumper Headers (Continued)

Jumper Header	Type	Description
P8	<p>1 2</p> 	<p>Jumper installed (factory default); on-board V_{DD} is selected as the source for V_{DDAD}.</p> <p>No jumper installed; V_{DDAD} is supplied from the target system.</p>

2.4.1 Clock Source Header (P3)

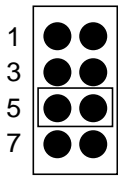
Jumper header P3 in **Figure 2-1** determines the clock signal source. The factory configuration (the fabricated jumper between pins 5 and 6) selects the clock signal from the MMDS control board or MMEVS platform board. You must use the system software to select the appropriate clock frequency.

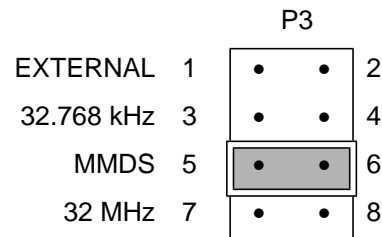

Figure 2-1. Jumper Header P3

Alternately, three other clock signal sources can be selected, as shown in **Figure 2-1**.

- To select the target system as the clock source, install the fabricated jumper between pins 1 and 2. Ensure that the clock source (OSC1) is connected to the EM through the target cable, connector P6 pin 3.
- To select the on-board 32.768-kHz crystal oscillator, install the fabricated jumper between pins 3 and 4.
- To select an on-board 32-MHz clock signal as the clock source, install the fabricated jumper between pins 7 and 8.

NOTE: *Only one jumper should be inserted on jumper header P3 at a time. Inserting multiple jumpers in P3 might damage the GP32EM.*

2.4.2 Factory Test Select Header (P5)

Jumper header P5 is for factory test use only and should be used only by Motorola factory personnel.

If the factory setting is changed, proper operation of the system cannot be guaranteed. **Figure 2-2** shows the default factory jumper header configuration, which has no fabricated jumper installed on jumper header P5 between pins 1 and 2.

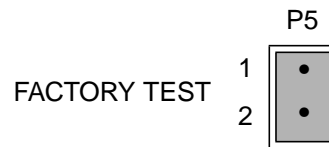

Figure 2-2. Jumper Header P5

2.4.3 Factory Test Select Header (P8)

Use jumper header P8 to select the power source for the MCU internal analog-to-digital (ADC) module

Install a jumper on jumper header P8 (factory default) when V_{DDAD} is not supplied from the target system. This allows use of the ADC module in the MC68HC908GP32 or MC68HC908GP20 MCUs when there is no target system V_{DDAD} power.

Remove the jumper on jumper header P8 when V_{DDAD} is provided by target system and an MC68HC908GP32 or MC68HC908GP20 MCU is being used.

Because V_{DD} and V_{DDAD} are connected internally in the MC68HC08JL3 MCU, the jumper on P8 must be installed when emulating JL3.

Alternately, remo

ve the jumper from P8 and connect an external power supply to P8 pin 1.

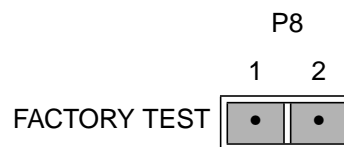

Figure 2-3. Jumper Header P8

2.5 Remaining System Installation

When all jumper headers are configured, follow these steps to complete the GP32EM installation:

- To install the GP32EM in an MMDS station module, remove the entire top half of the station-module enclosure. Fit together EM connectors P1 and P2 (on the bottom of the board) and control-board connectors P1 and P2. Snap the corners of the EM onto the plastic standoffs.
- To install the GP32EM on an MMEVS platform board, fit together EM connectors P1 and P2 (on the bottom of the board) and platform-board connectors P3 and P4. Snap the corners of the EM onto the plastic standoffs.
- Copy the personality files from the provided diskette to the directory that contains the debugging software. The personality files for the GP32EM are:
 - 00455Vxx.MEM — Personality file for MC68HC908GP32 MCU
 - 0GP20Vxx.MEM — Personality file for MC68HC908GP20 MCU
 - 0JL3Vxx.MEM — Personality file for MC68HC908JL3 MCU

At this point, make any system cable connections and restore power. For instructions, consult the MMDS or MMEVS operations manuals.

Section 3. Connector Information

3.1 Contents

3.2	Introduction.	21
3.3	Logic Analyzer Connector (P1)	22
3.4	Target Connectors (P6 and P7).	25
3.5	Target Cable Assembly.	30

3.2 Introduction

This section consists of pin assignments and signal descriptions for M68EML08GP32 target and logic analyzer connectors.

3.3 Logic Analyzer Connector (P1)

Connector P1 is the GP32EM logic analyzer connector.

Figure 3-1 shows the pin assignments for connector P1. **Table 3-1** gives the signal descriptions.

		P1			
GND	1	• •	2	GND	
AD7	3	• •	4	GND	
AD6	5	• •	6	LA13	
AD5	7	• •	8	LA12	
AD4	9	• •	10	LA11	
AD3	11	• •	12	LA10	
AD2	13	• •	14	LA9	
AD1	15	• •	16	LA8	
AD0	17	• •	18	LA7	
$\overline{\text{LIR}}$	19	• •	20	LA6	
R/W	21	• •	22	LA5	
GND	23	• •	24	LA4	
PHI2	25	• •	26	LA3	
LBOX	27	• •	28	LA2	
$\overline{\text{BREAK}}$	29	• •	30	LA1	
GND	31	• •	32	LA0	
GND	33	• •	34	GND	
GND	35	• •	36	GND	
$\overline{\text{IRQ}}$	37	• •	38	$\overline{\text{RESET}}$	
V_{DD}	39	• •	40	GND	

Figure 3-1. Logic Analyzer Connector P1 Pin Assignments

**Table 3-1. Logic Analyzer Connector P1
Signal Descriptions**

Pin	Mnemonic	Signal
1, 2	GND	GROUND
3	AD7	Data bus bit 7 — MCU bidirectional data bus
4	GND	GROUND
5	AD6	Data bus bit 6 — MCU bidirectional data bus
6	LA13	Address bus bit 13 — MCU output address bus
7	AD5	Data bus bit 5 — MCU bidirectional data bus
8	LA12	Address bus bit 12 — MCU output address bus
9	AD4	Data bus bit 4 — MCU bidirectional data bus
10	LA11	Address bus bit 11 — MCU output address bus
11	AD3	Data bus bit 3 — MCU bidirectional data bus
12	LA10	Address bus bit 10 — MCU output address bus
13	AD2	Data bus bit 2 — MCU bidirectional data bus
14	LA9	Address bus bit 9 — MCU output address bus
15	AD1	Data bus bit 1 — MCU bidirectional data bus
16	LA8	Address bus bit 8 — MCU output address bus
17	AD0	Data bus bit 0 — MCU bidirectional data bus
18	LA7	Address bus bit 7 — MCU output address bus
19	$\overline{\text{LIR}}$	Load instruction register — Active-low output signal, asserted when an instruction starts
20	LA6	Address bus bit 6 — MCU output address bus
21	R/W	Read/Write — Output signal that indicates the direction of data transfer
22	LA5	Address bus bit 5 — MCU output address bus
23	GND	GROUND
24	LA4	Address bus bit 4 — MCU output address bus
25	PHI2	PHI2 clock — Internally generated output clock signal used as a timing reference
26	LA3	Address bus bit 3 — MCU output address bus

**Table 3-1. Logic Analyzer Connector P1
Signal Descriptions (Continued)**

Pin	Mnemonic	Signal
27	LBOX	Last bus cycle — Input signal that the emulator asserts to indicate that the target system MCU is in the last bus cycle of an instruction
28	LA2	Address bus bit 2 — MCU output address bus
29	$\overline{\text{BREAK}}$	$\overline{\text{BREAK}}$ — Active low signal that the EM asserts to stop the target system MCU from running user code
30	LA1	Address bus bit 1 — MCU output address bus
31	GND	GROUND
32	LA0	Address bus bit 0 — MCU output address bus
38	$\overline{\text{RESET}}$	$\overline{\text{RESET}}$ — Active-low bidirectional signal for starting an EVS reset
37	GND	GROUND
39	V _{DD}	+5 Vdc power — Input voltage (+5 Vdc @ 1 A (max)) used by the EM logic circuits
40	GND	GROUND
31	GND	GROUND

3.4 Target Connectors (P6 and P7)

GP32EM has two target connectors: P6 and P7, each a 2-row by-20-pin connector.

Figure 3-1, **Table 3-2**, and **Table 3-3** give the pin assignments and signal descriptions for these connectors.

P6				P7			
V _{SS}	1	• •	2 PTC1	$\overline{\text{RESET}}$	1	• •	2 PTC0
NC	3	• •	4 V _{SS}	OSC1	3	• •	4 PTC2
V _{SS}	5	• •	6 PTC4	NC	5	• •	6 PTC3
PTA7	7	• •	8 RESERVED	RESERVED	7	• •	8 PTC5
PTA6 (GP32)	9	• •	10 NC	V _{SS}	9	• •	10 PTC6
PTA4	11	• •	12 NC	PTA5	11	• •	12 NC
PTA2	13	• •	14 NC	PTA3	13	• •	14 V _{SS}
PTA0	15	• •	16 NC	PTA1	15	• •	16 NC
V _{DDAD}	17	• •	18 NC	V _{SSAD}	17	• •	18 NC
V _{SS}	19	• •	20 NC	PTB7	19	• •	20 NC
PTA6 (JL3)	21	• •	22 PTB5	NC	21	• •	22 PTB6
NC	23	• •	24 V _{SS}	NC	23	• •	24 PTB4
NC	25	• •	26 PTB2	NC	25	• •	26 PTB3
NC	27	• •	28 PTB0	V _{SS}	27	• •	28 PTB1
NC	29	• •	30 PTD6 (GP32)	NC	29	• •	30 PTD7 (GP32)
NC	31	• •	32 PTD5	PTD6 (JL3)	31	• •	32 V _{SS}
NC	33	• •	34 V _{DD}	PTD7 (JL3)	33	• •	34 PTD4
PTE1	35	• •	36 PTD3	PTE0	35	• •	36 V _{SS}
PTD0	37	• •	38 V _{SS}	$\overline{\text{IRQ}}$	37	• •	38 V _{SS}
PTD2	39	• •	40 V _{SS}	PTD1	39	• •	40 V _{SS}

Figure 3-2. Target Connectors P6 and P7 Pin Assignments

Table 3-2. Target Connectors P6 Signal Descriptions

Pin	Mnemonic	Signal
1	V_{SS}	EM GROUND — Ground signal of the EM board
2	PTC1	PORT C (bit 1) — General-purpose I/O lines controlled by software via data direction and data registers
3	NC	No connect
4, 5	V_{SS}	EM GROUND — Ground signal of the EM board
6	PTC4	PORT C (bit 4) — General-purpose I/O lines controlled by software via data direction and data registers
7	PTA7	PORT A (bit 7) — General-purpose I/O lines controlled by software via data direction and data registers
8	RESERVED	Reserved
9	PTA6 (GP32)	PORT A (bit 6) — General-purpose I/O lines controlled by software via data direction and data registers
10	NC	No connect
11	PTA4	PORT A (bit 4) — General-purpose I/O lines controlled by software via data direction and data registers
12	NC	No connect
13	PTA2	PORT A (bit 2) — General-purpose I/O lines controlled by software via data direction and data registers
14	NC	No connect
15	PTA0	PORT A (bit 0) — General-purpose I/O lines controlled by software via data direction and data registers
16	NC	No connect
17	V_{DDAD}	Analog-to-digital input voltage — ADC input voltage. Use the same voltage level as V_{DD} .
18	NC	No connect
19	V_{SS}	EM GROUND — Ground signal of the EM board
20	NC	No connect
21	PTA6 (JL3)	PORT A (bit 6) — General-purpose I/O lines controlled by software via data direction and data registers
22	PTB5	PORT B (bit 5) — General-purpose I/O lines controlled by software via data direction and data registers
23	NC	No connect

Table 3-2. Target Connectors P6 Signal Descriptions (Continued)

Pin	Mnemonic	Signal
24	V _{SS}	EM GROUND – Ground signal of the EM board.
25	NC	No connect
26	PTB2	PORT B (bit 2) — General-purpose I/O lines controlled by software via data direction and data registers
27	NC	No connect
28	PTB0	PORT B (bit 0) — General-purpose I/O lines controlled by software via data direction and data registers
29	NC	No connect
30	PTD6 (GP32)	PORT D (bit 6) — General-purpose I/O lines controlled by software via data direction and data registers
31	NC	No connect
32	PTD5	PORT D (bit 5) — General-purpose I/O lines controlled by software via data direction and data registers
33	NC	No connect
34	V _{DD}	MMDS +5 V — Used for factory testing
35	PTE1	PORT E (bit 1) — General-purpose I/O lines controlled by software via data direction and data registers
36	PTD3	PORT D (bit 3) — General-purpose I/O lines controlled by software via data direction and data registers
37	PTD0	PORT D (bit 0) — General-purpose I/O lines controlled by software via data direction and data registers
38	V _{SS}	EM GROUND — Ground signal of the EM board
39	PTD2	PORT D (bit 2) — General-purpose I/O lines controlled by software via data direction and data registers
40	V _{SS}	EM GROUND — Ground signal of the EM board

Table 3-3. Target Connectors P7 Signal Descriptions

Pin	Mnemonic	Signal
1	$\overline{\text{RESET}}$	$\overline{\text{RESET}}$ — Active-low bidirectional control line that initializes the MCU
2	PTC0	PORT C (bit 0) — General-purpose I/O lines controlled by software via data direction and data registers
3	OSC1	OSCILLATOR — Crystal oscillator amplifier input signal
4	PTC2	PORT C (bit 2) — General-purpose I/O lines controlled by software via data direction and data registers
5	NC	No connect
6	PTC3	PORT C (bit 3) — General-purpose I/O lines controlled by software via data direction and data registers
7	RESERVED	Reserved
8	PTC5	PORT C (bit 5) — General-purpose I/O lines controlled by software via data direction and data registers
9	VSS	EM GROUND — Ground signal of the EM board
10	PTC6	PORT C (bit 6) — General-purpose I/O lines controlled by software via data direction and data registers
11	PTA5	PORT A (bit 5) — General-purpose I/O lines controlled by software via data direction and data registers
12	NC	No connect
13	PTA3	PORT A (bit 3) — General-purpose I/O lines controlled by software via data direction and data registers
14	V_{SS}	EM GROUND — Ground signal of the EM board
15	PTA1	PORT A (bit 1) — General-purpose I/O lines controlled by software via data direction and data registers
16	NC	No connect
17	V_{SSAD}	ANALOG-TO-DIGITAL GROUND — ADC ground
18	NC	No connect
19	PTB7	PORT B (bit 7) — General-purpose I/O lines controlled by software via data direction and data registers
20, 21	NC	No connect
22	PTB6	PORT B (bit 6) — General-purpose I/O lines controlled by software via data direction and data registers

Table 3-3. Target Connectors P7 Signal Descriptions (Continued)

Pin	Mnemonic	Signal
23	NC	No connect
24	PTB4	PORT B (bit 4) — General-purpose I/O lines controlled by software via data direction and data registers
25	NC	No connect
26	PTB3	PORT B (bit 3) — General-purpose I/O lines controlled by software via data direction and data registers
27	V _{SS}	EM GROUND — Ground signal of the EM board
28	PTB1	PORT B (bit 1) — General-purpose I/O lines controlled by software via data direction and data registers
29	NC	No connect
30	PTD7 (GP32)	PORT D (bit 7) — General-purpose I/O lines controlled by software via data direction and data registers
31	PTD6 (JL3)	PORT D (bit 6) — General-purpose I/O lines controlled by software via data direction and data registers
32	V _{SS}	EM GROUND — Ground signal of the EM board
33	PTD7 (JL3)	PORT D (bit 7) — General-purpose I/O lines controlled by software via data direction and data registers
34	PTD4 (JL3)	PORT D (bit 4) — General-purpose I/O lines controlled by software via data direction and data registers
35	PTE0	PORT E (bit 0) — General-purpose I/O lines controlled by software via data direction and data registers
36	V _{SS}	EM GROUND — Ground signal of the EM board
37	$\overline{\text{IRQ}}$	INTERRUPT REQUEST — Active-low input line for requesting MCU asynchronous non-maskable interrupt
38	V _{SS}	EM GROUND — Ground signal of the EM board
39	PTD1	PORT D (bit 1) — General-purpose I/O lines controlled by software via data direction and data registers
40	V _{SS}	EM GROUND — Ground signal of the EM board

3.5 Target Cable Assembly

To connect the GP32EM to a target system, a separately purchased target cable assembly is needed, plus the appropriate target head and target-head/adaptor package.

Figure 3-3 shows how one end of the flex cable plugs into the GP32EM module, and it also shows how the target head connects into the target system.

If the GP32EM is installed in the MMDS station module, run the flex cable through the slit in the station-module enclosure.

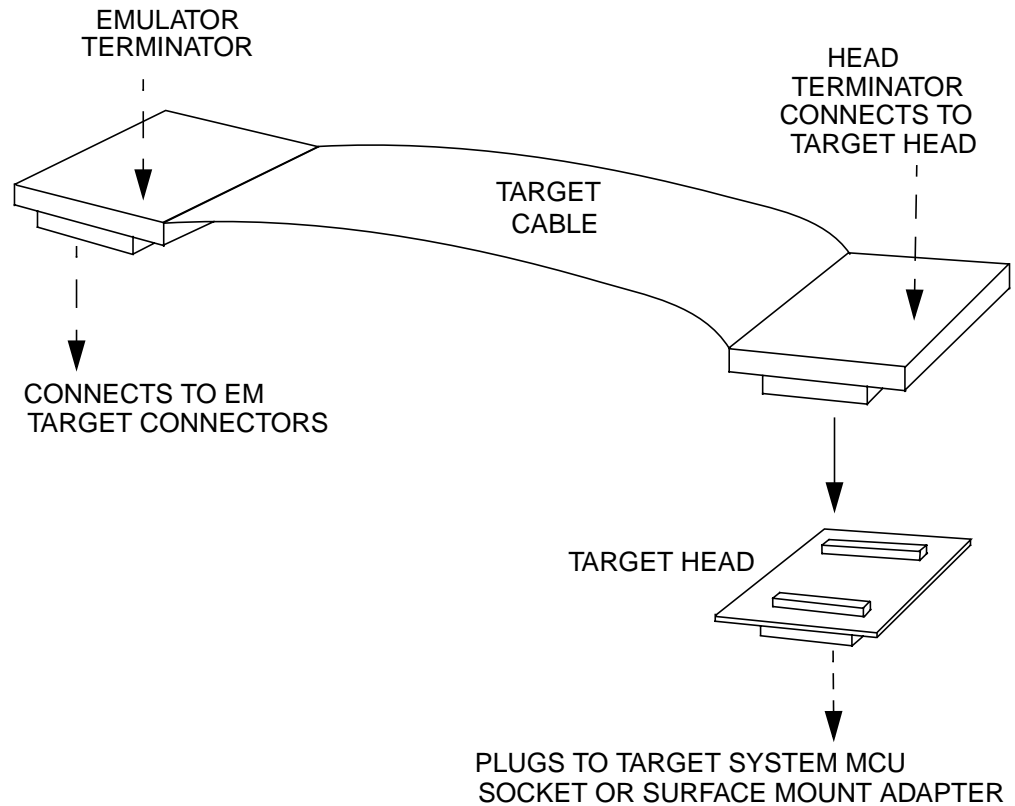

Figure 3-3. Target Cable Assembly

Section 4. Schematics

This chapter contains the M68EML08GP32 emulator module schematic diagrams.

These schematic diagrams are for reference only and may deviate slightly from the circuits on the GP32EM.

ode)

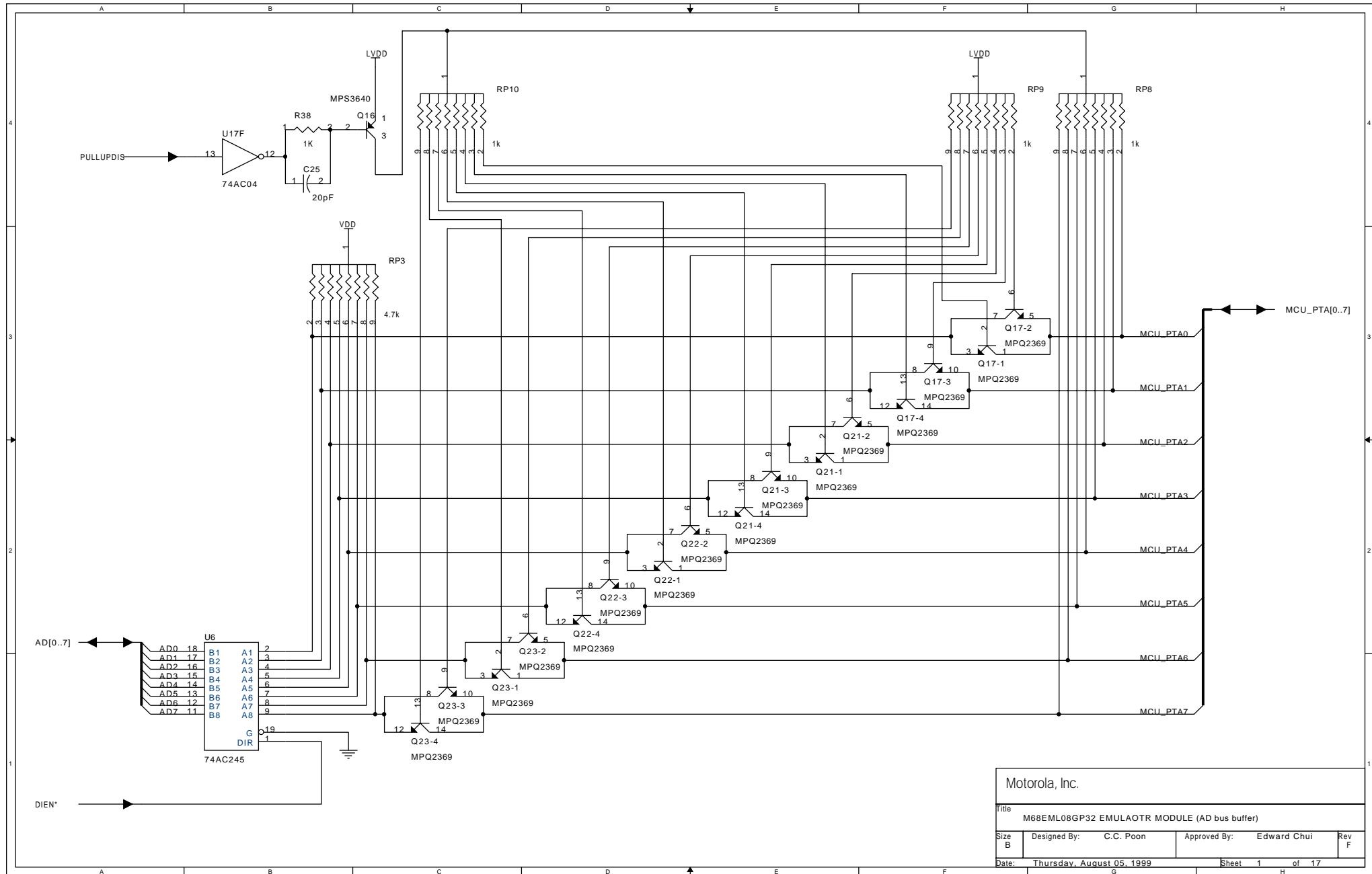

Motorola, Inc.				
Title M68EML08GP32 EMULAOTR MODULE (AD bus buffer)				
Size B	Designed By: C.C. Poon	Approved By: Edward Chui	Rev F	
Date: Thursday, August 05, 1999		Sheet 1 of 17		

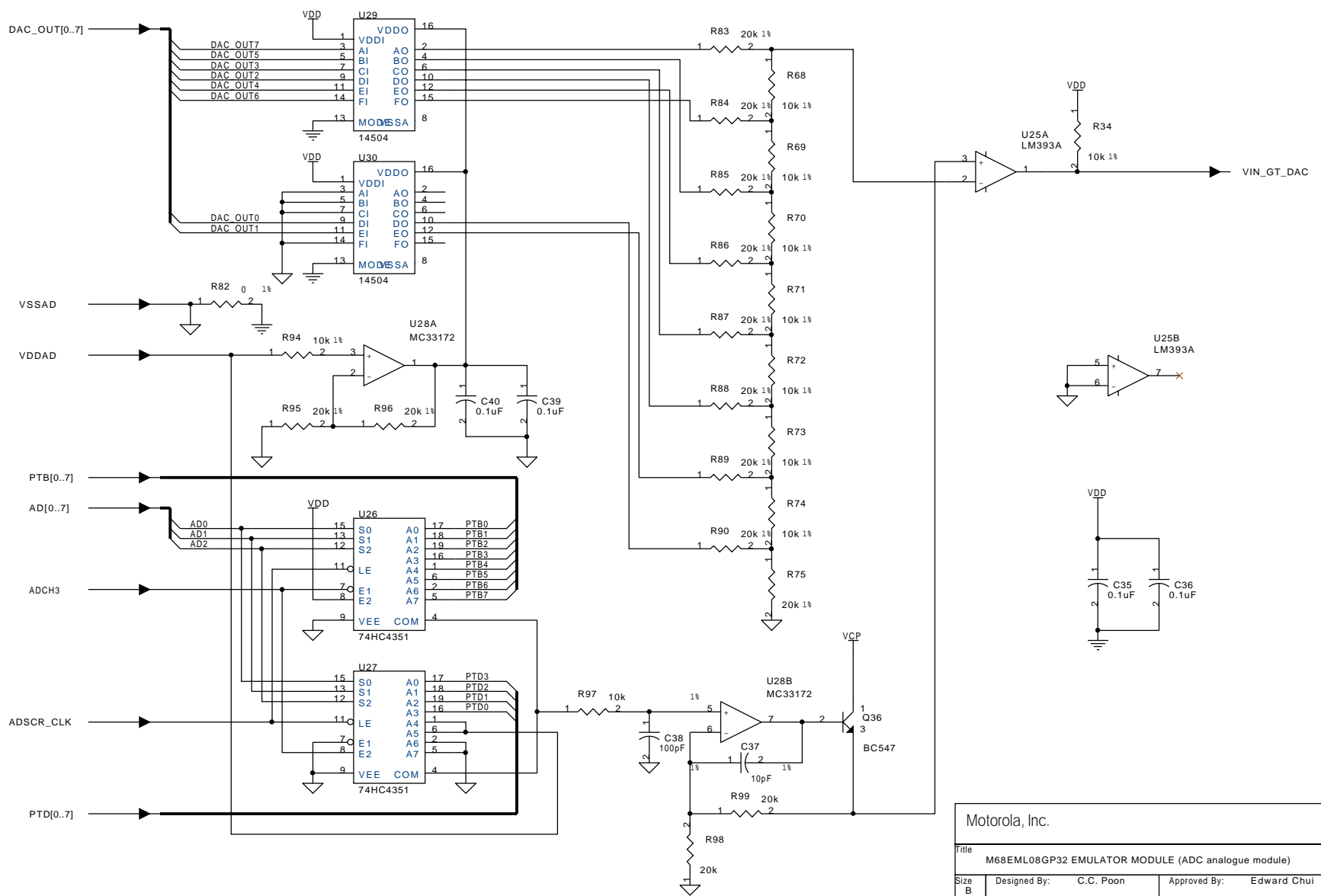

Motorola, Inc.			
Title M68EML08GP32 EMULATOR MODULE (ADC analogue module)			
Size B	Designed By: C.C. Poon	Approved By: Edward Chui	Rev F
Date: Thursday, August 12, 1999		Sheet 2 of 17	

ode)

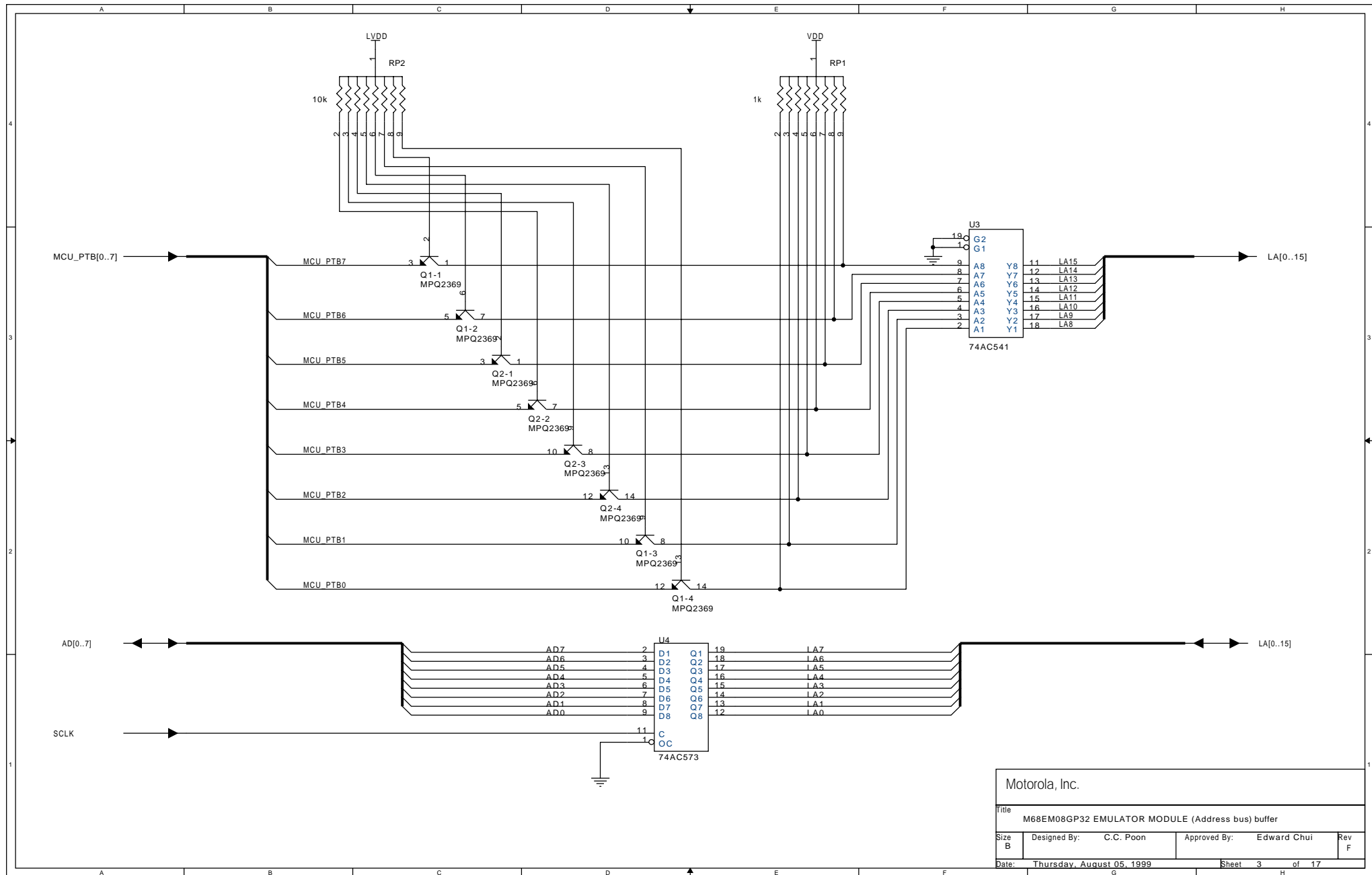

Motorola, Inc.			
Title M68EM08GP32 EMULATOR MODULE (Address bus) buffer			
Size B	Designed By: C.C. Poon	Approved By: Edward Chui	Rev F
Date: Thursday, August 05, 1999		Sheet 3 of 17	

ode)

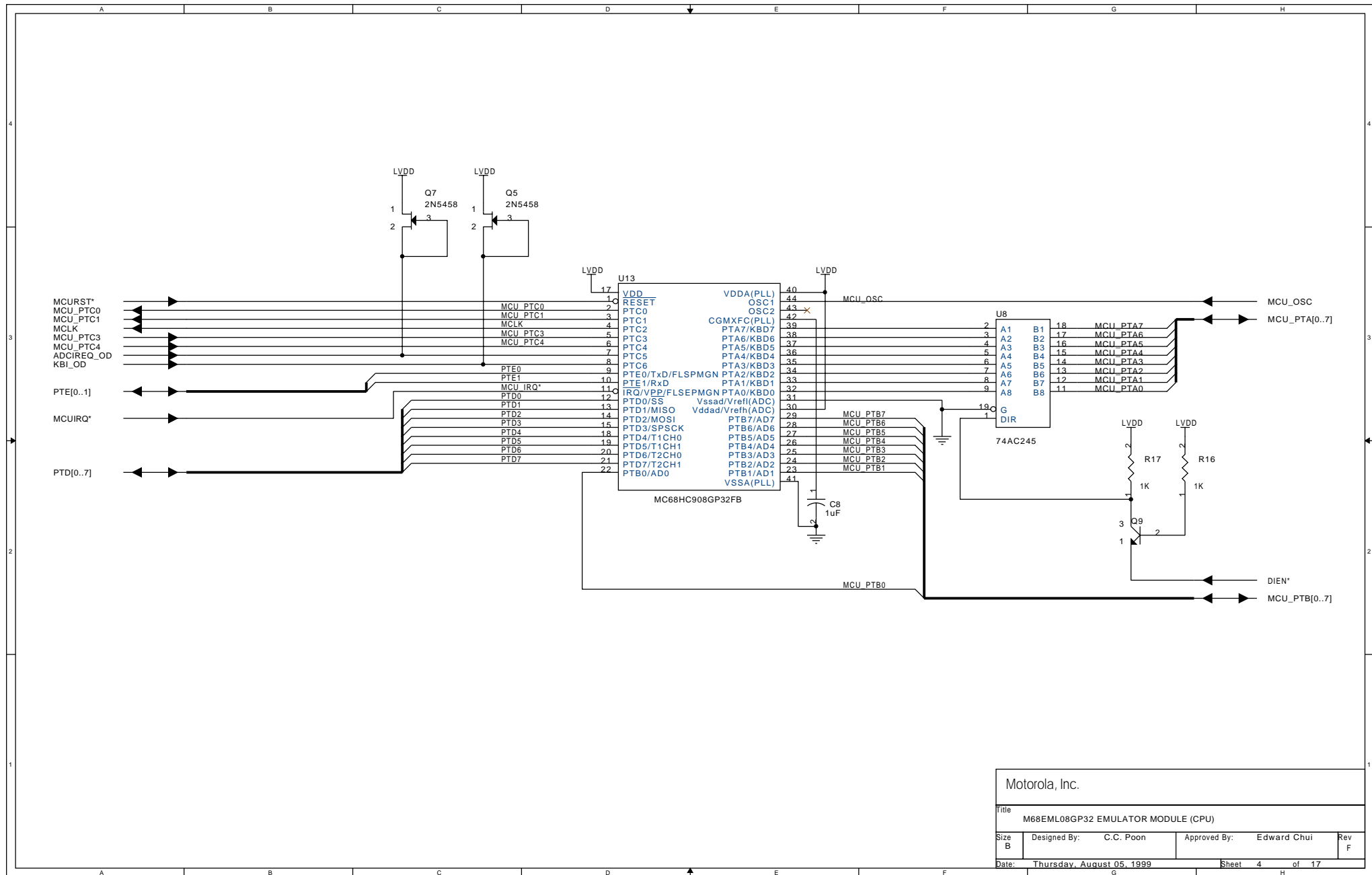

Motorola, Inc.				
Title M68EML08GP32 EMULATOR MODULE (CPU)				
Size B	Designed By: C.C. Poon	Approved By: Edward Chui	Rev F	
Date: Thursday, August 05, 1999	Sheet 4 of 17			

ode)

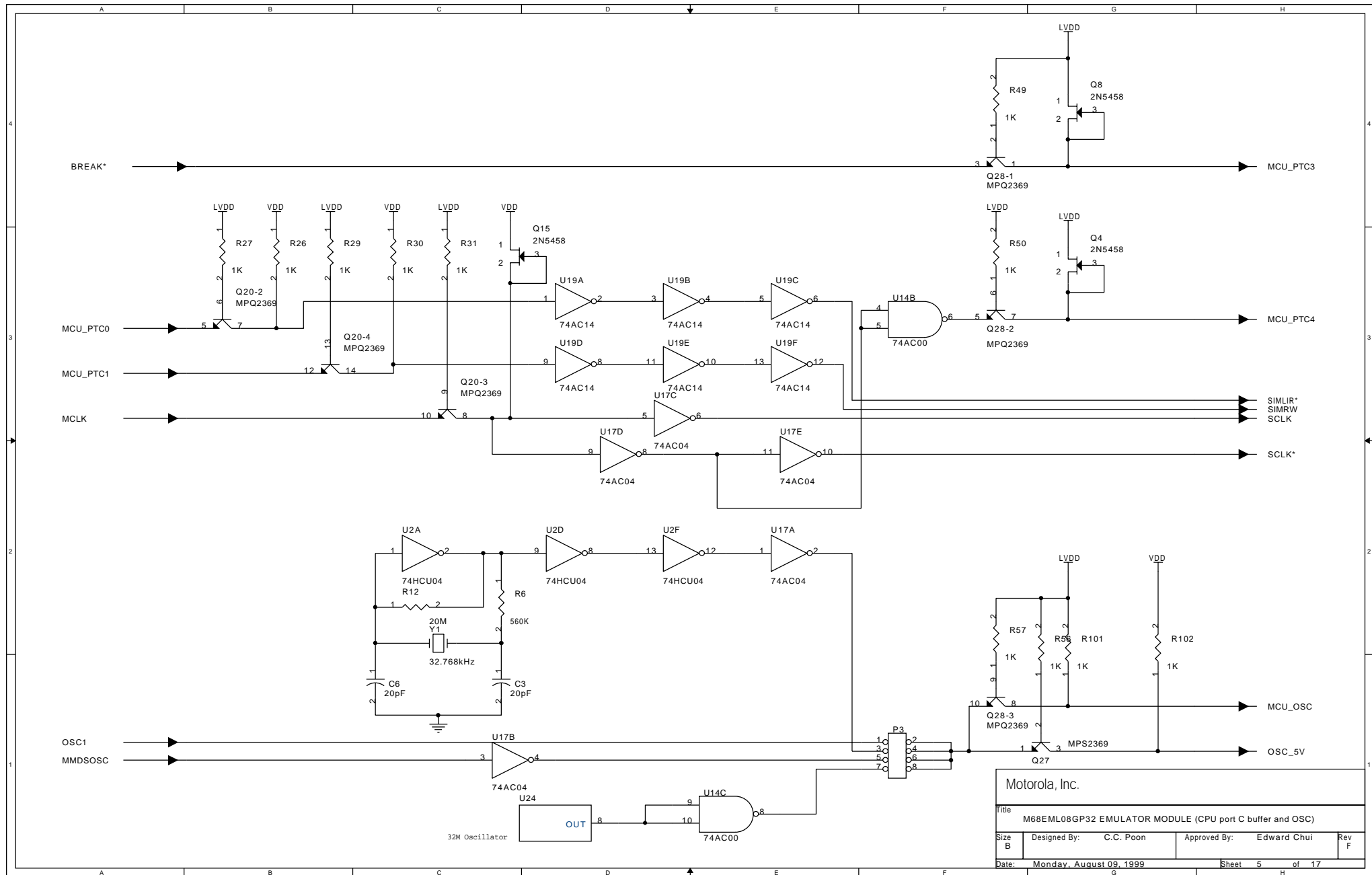

Motorola, Inc.

Title			
M68EML08GP32 EMULATOR MODULE (CPU port C buffer and OSC)			
Size B	Designed By: C.C. Poon	Approved By: Edward Chui	Rev F
Date: Monday, August 09, 1999		Sheet 5 of 17	

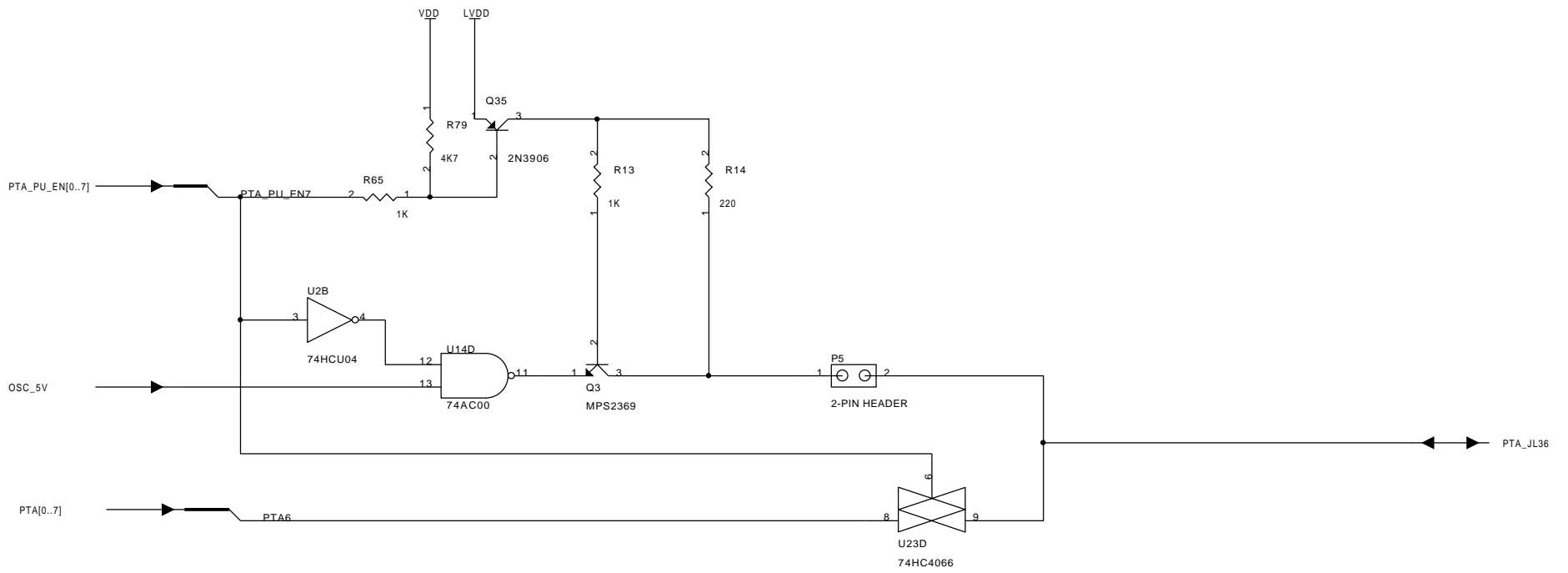

Motorola, Inc.				
Title M68EML08GP32 EMULAOTR MODULE (JL3 PORT A EMULATION)				
Size B	Designed By: C.C. Poon	Approved By: Edward Chui	Rev F	
Date: Thursday, August 05, 1999	Sheet 6		of 17	

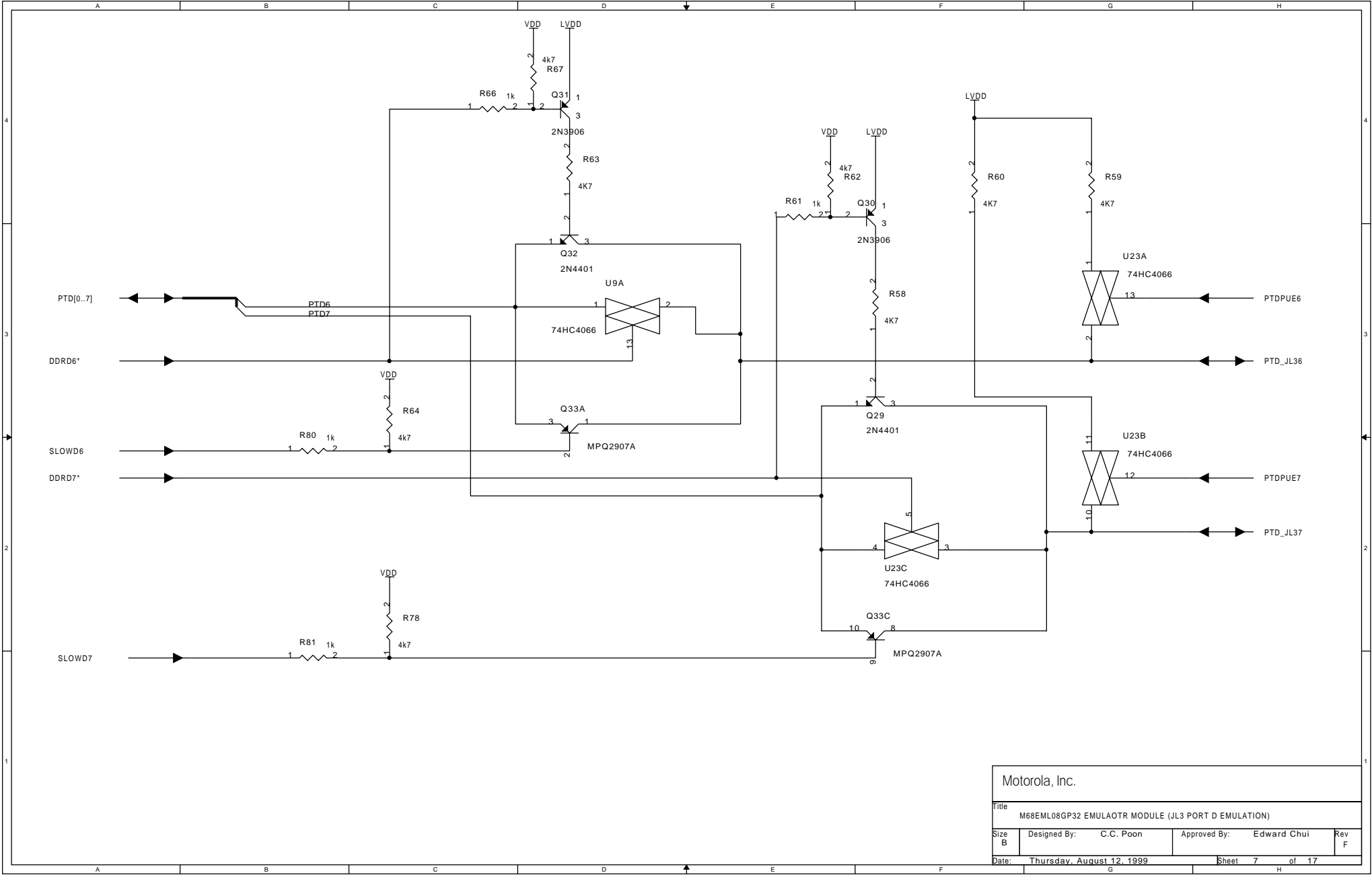

Motorola, Inc.				
Title M68EML08GP32 EMULAOTR MODULE (JL3 PORT D EMULATION)				
Size B	Designed By: C.C. Poon	Approved By: Edward Chui	Rev F	
Date: Thursday, August 12, 1999			Sheet 7 of 17	

ode)

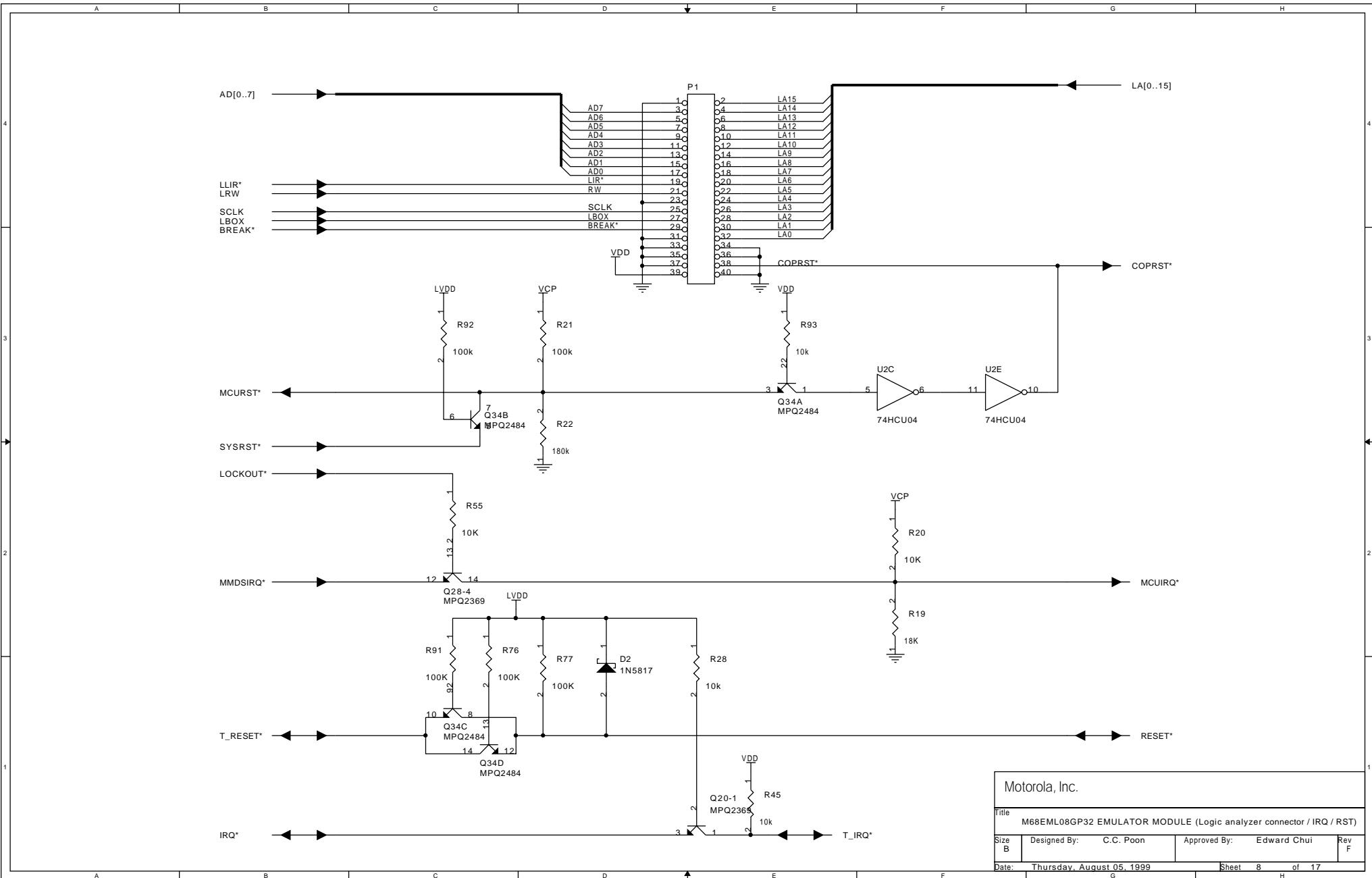

Motorola, Inc.				
Title M68EML08GP32 EMULATOR MODULE (Logic analyzer connector / IRQ / RST)				
Size B	Designed By: C.C. Poon	Approved By: Edward Chui	Rev F	
Date: Thursday, August 05, 1999		Sheet 8 of 17		

ode)

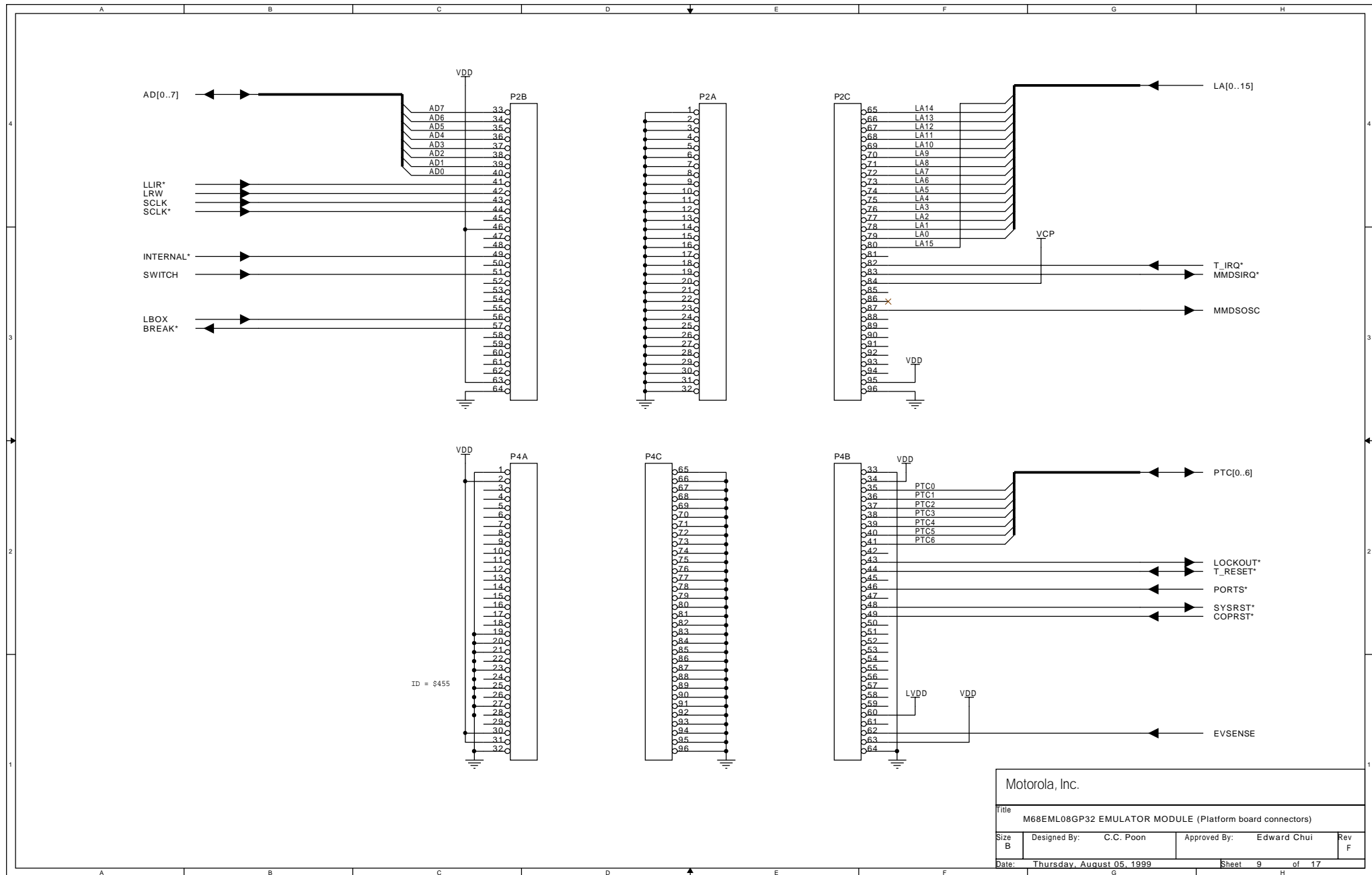

Motorola, Inc.			
Title M68EML08GP32 EMULATOR MODULE (Platform board connectors)			
Size B	Designed By: C.C. Poon	Approved By: Edward Chui	Rev F
Date: Thursday, August 05, 1999	Sheet 9 of 17		

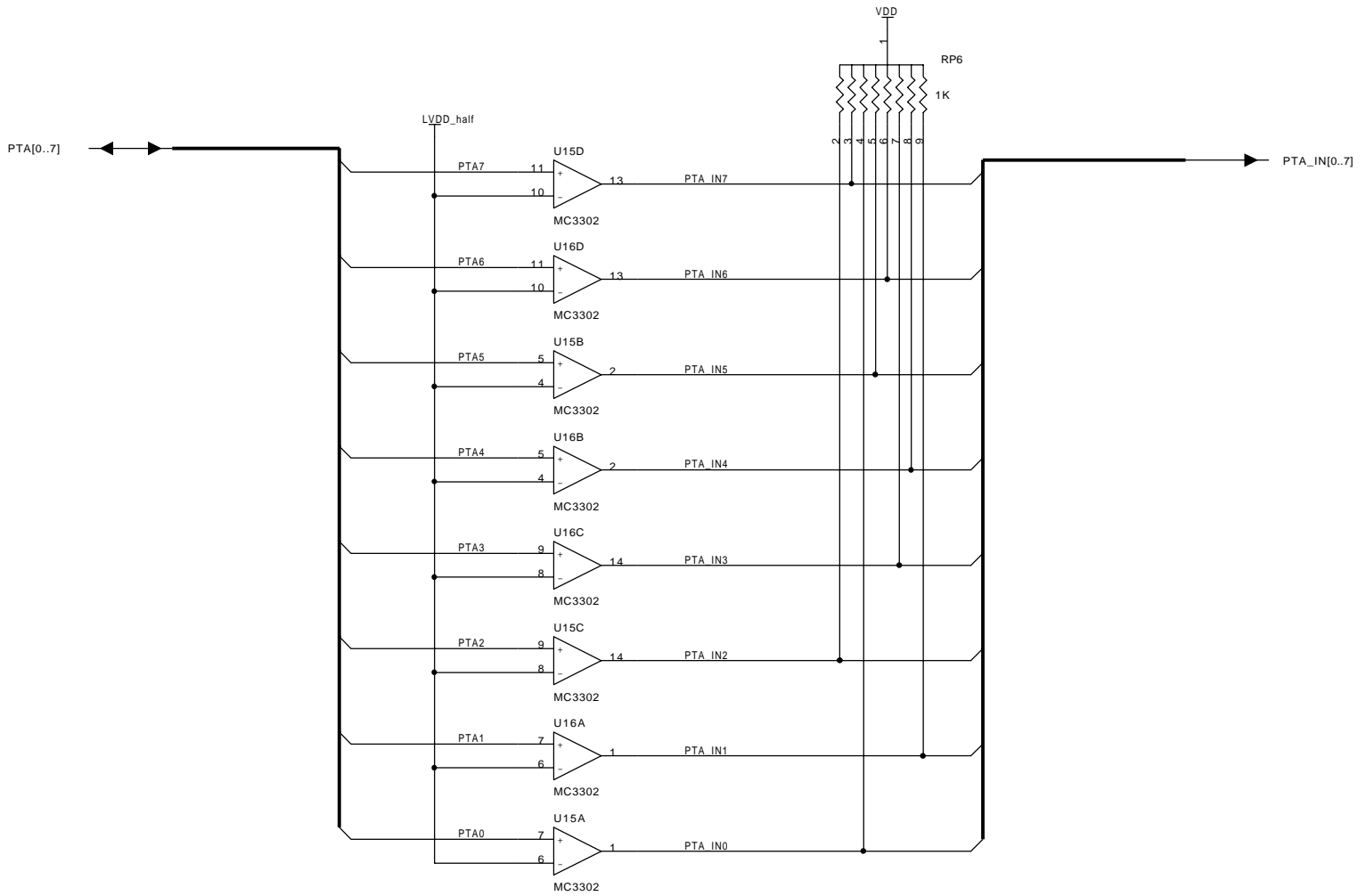

Motorola, Inc.			
Title M68EML08GP32 EMULATOR MODULE (Port A input comparator)			
Size B	Designed By: C.C. Poon	Approved By: Edward Chui	Rev F
Date: Thursday, August 05, 1999	Sheet 10 of 17		

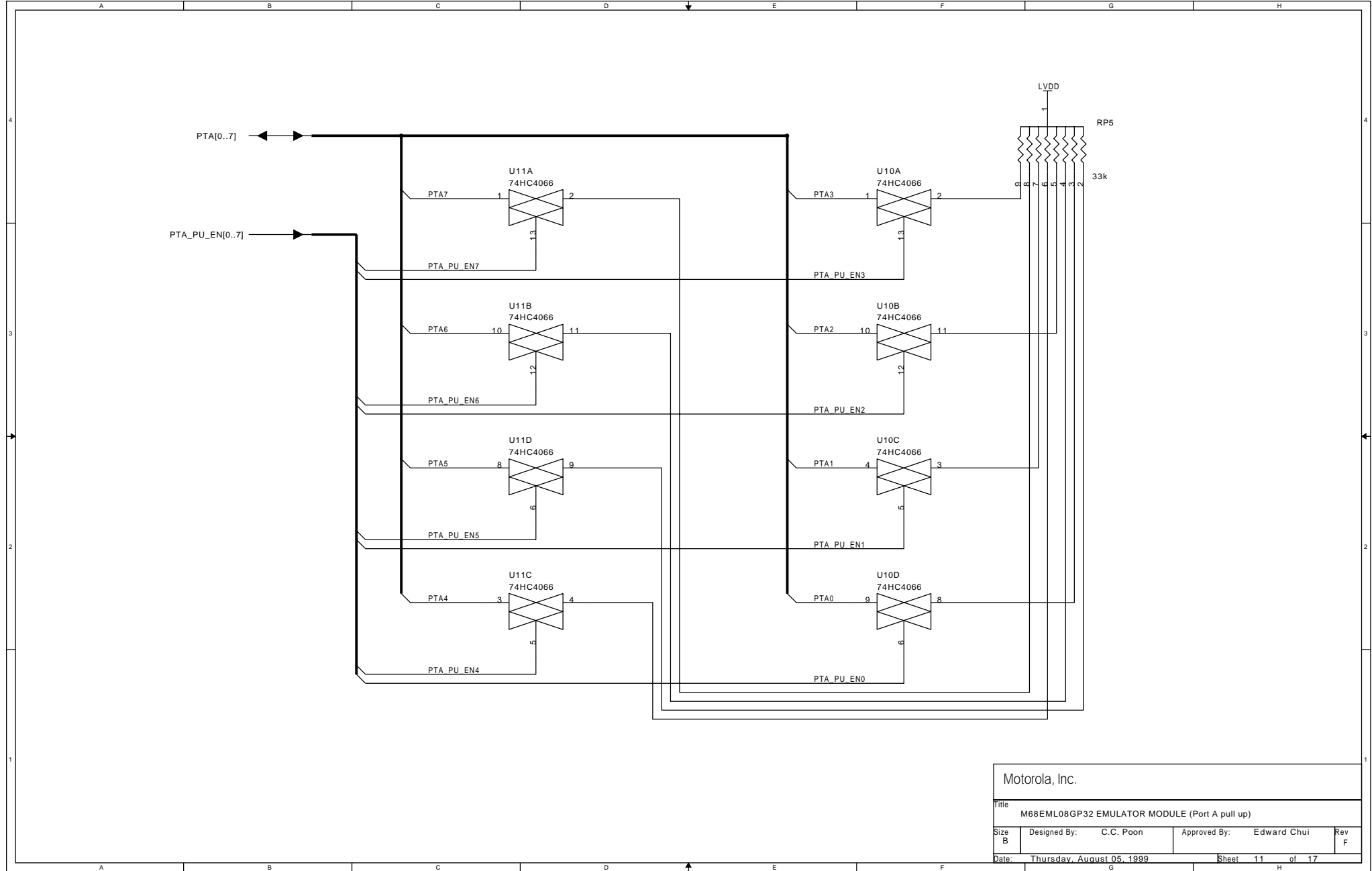

Motorola, Inc.				
Title M68EML08GP32 EMULATOR MODULE (Port A pull up)				
Size B	Designed By: C.C. Poon	Approved By: Edward Chui	Rev F	
Date: Thursday, August 05, 1999	Sheet 11 of 17			

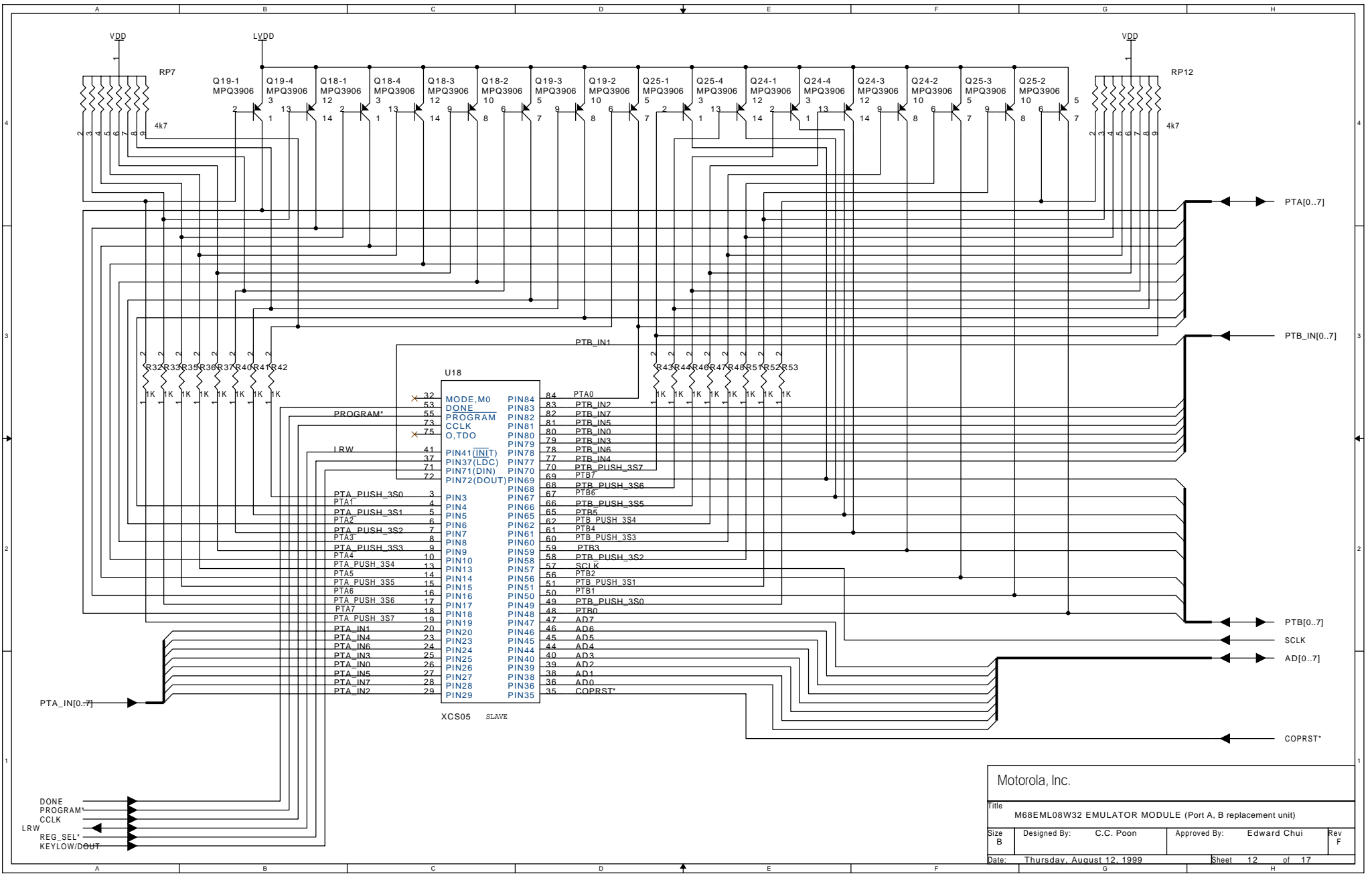

Motorola, Inc.				
Title M68EML08W32 EMULATOR MODULE (Port A, B replacement unit)				
Size B	Designed By: C.C. Poon	Approved By: Edward Chui	Rev F	
Date: Thursday, August 12, 1999	Sheet 12 of 17			

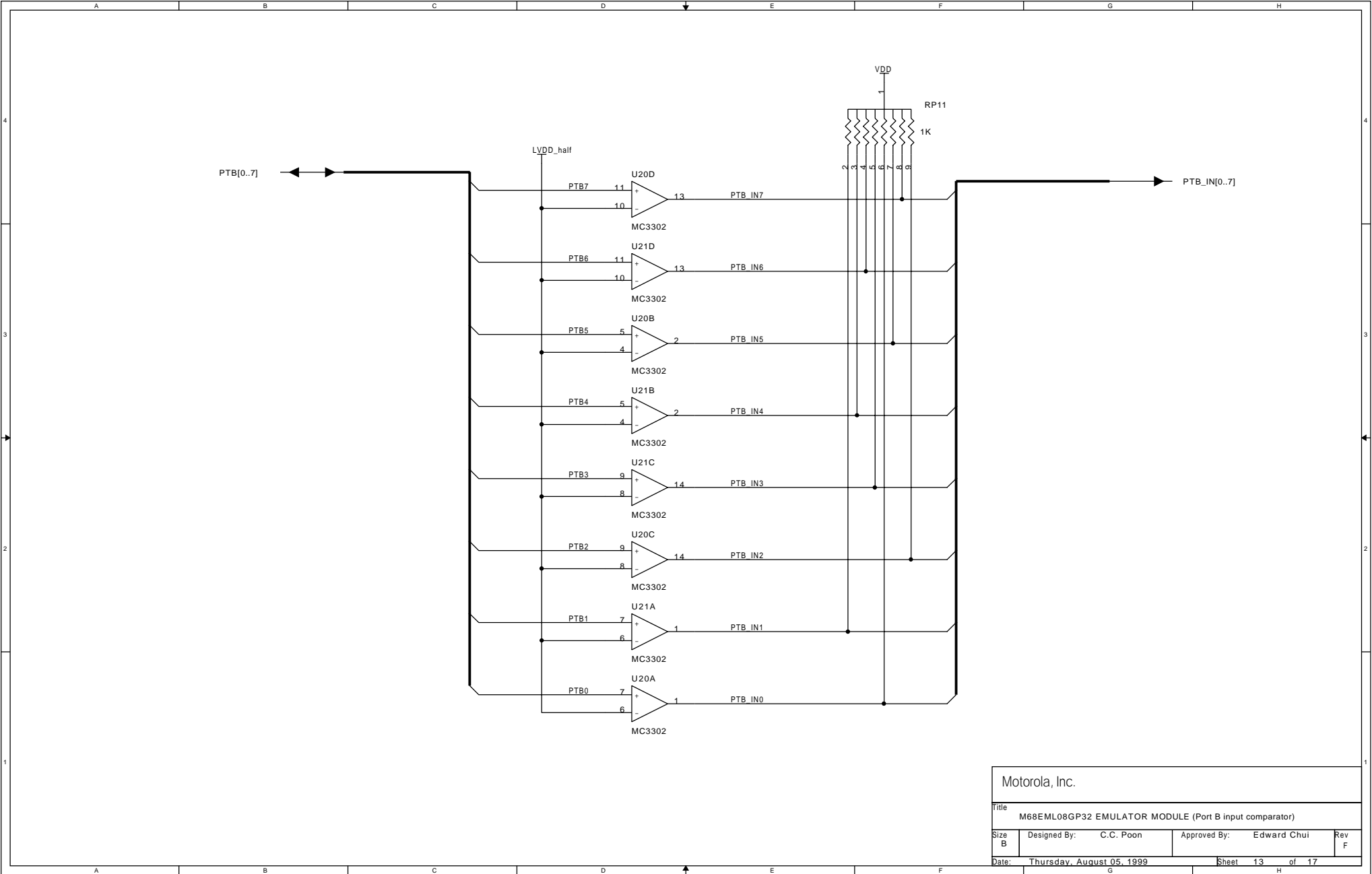

Motorola, Inc.			
Title M68EML08GP32 EMULATOR MODULE (Port B input comparator)			
Size B	Designed By: C.C. Poon	Approved By: Edward Chui	Rev F
Date: Thursday, August 05, 1999	Sheet 13 of 17		

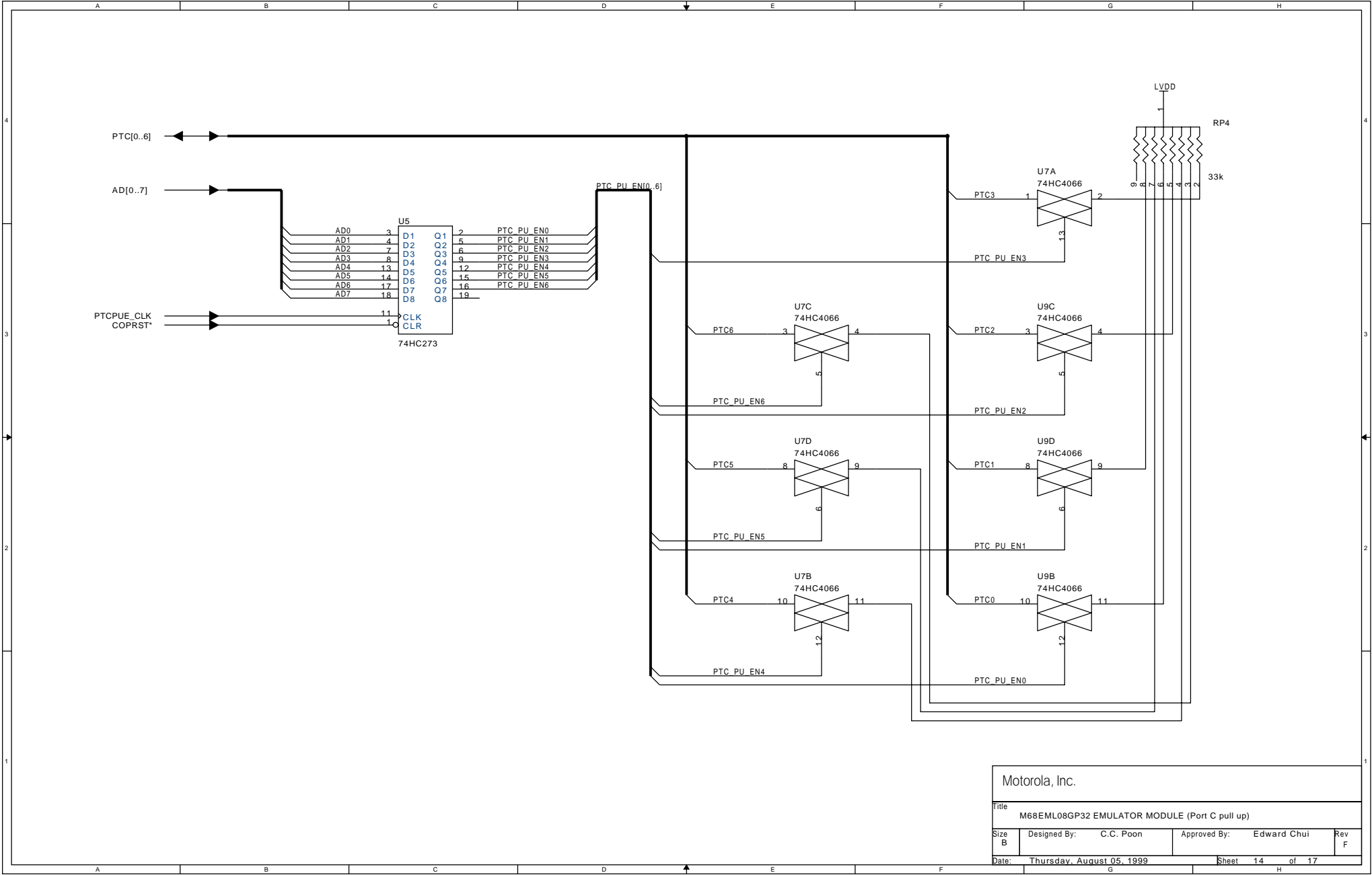

Motorola, Inc.			
Title M68EML08GP32 EMULATOR MODULE (Port C pull up)			
Size B	Designed By: C.C. Poon	Approved By: Edward Chui	Rev F
Date: Thursday, August 05, 1999	Sheet 14 of 17		

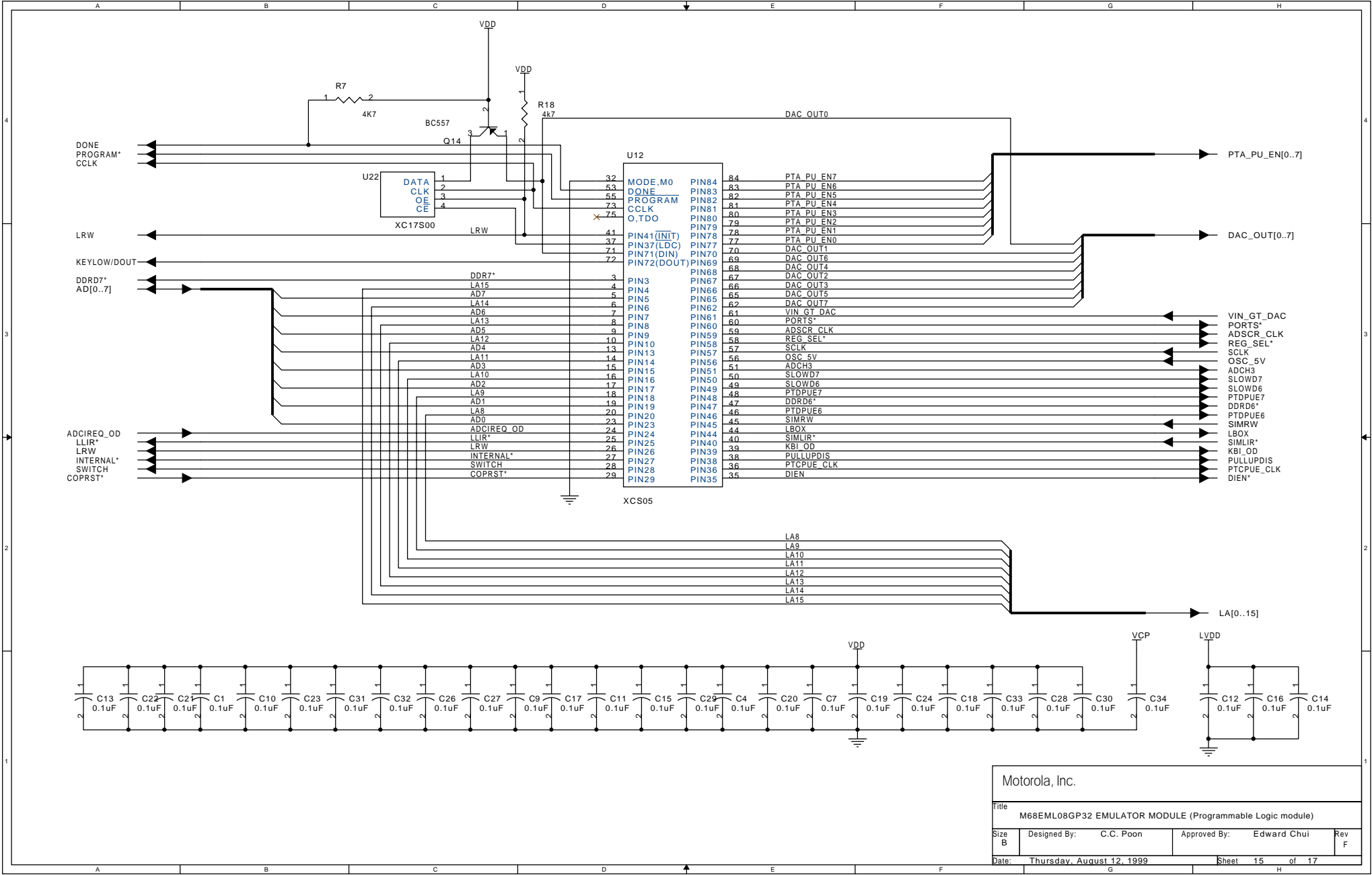

ode)

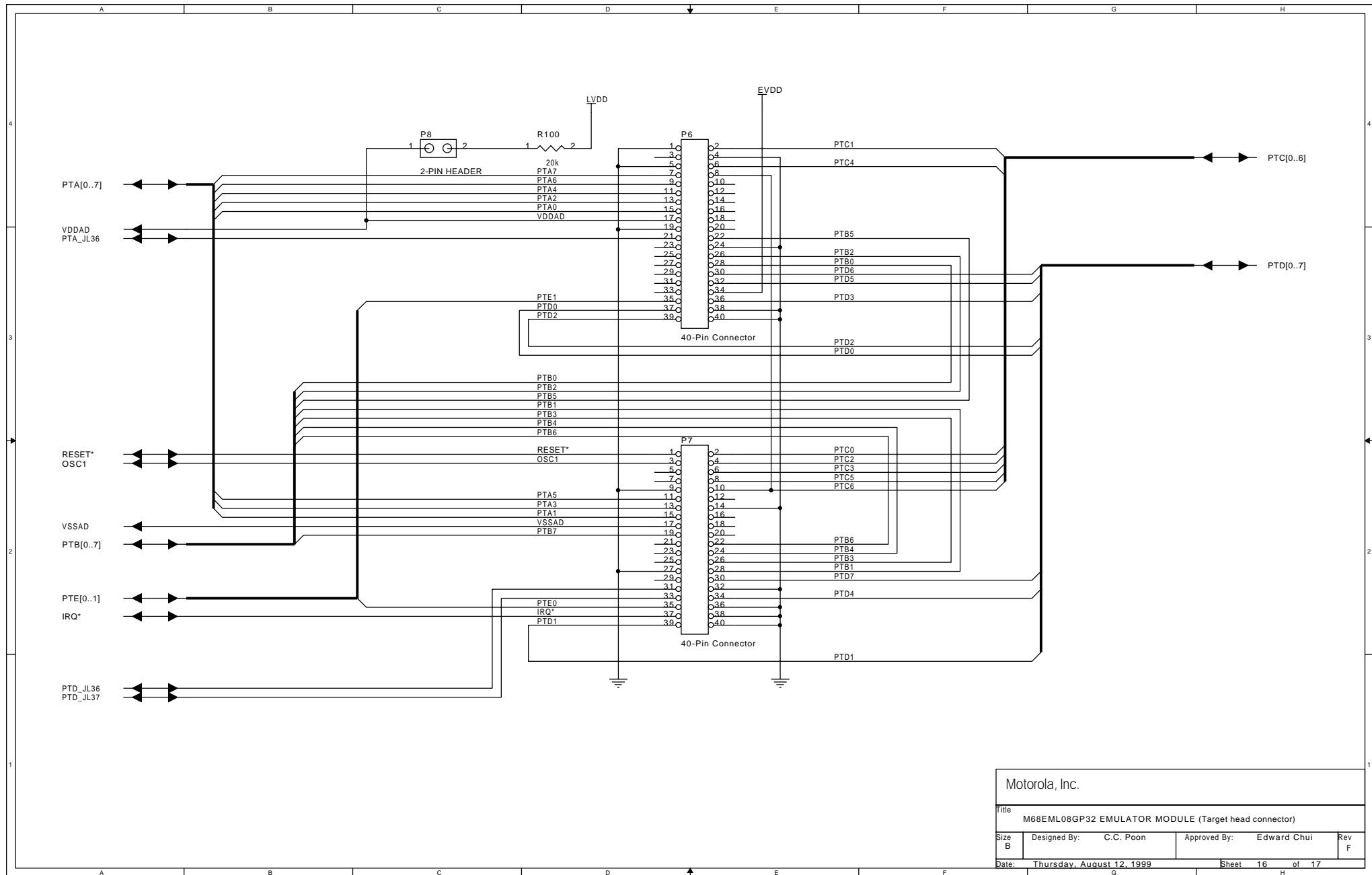

Motorola, Inc.			
Title M68EML08GP32 EMULATOR MODULE (Target head connector)			
Size B	Designed By: C.C. Poon	Approved By: Edward Chui	Rev F
Date: Thursday, August 12, 1999		Sheet 16 of 17	

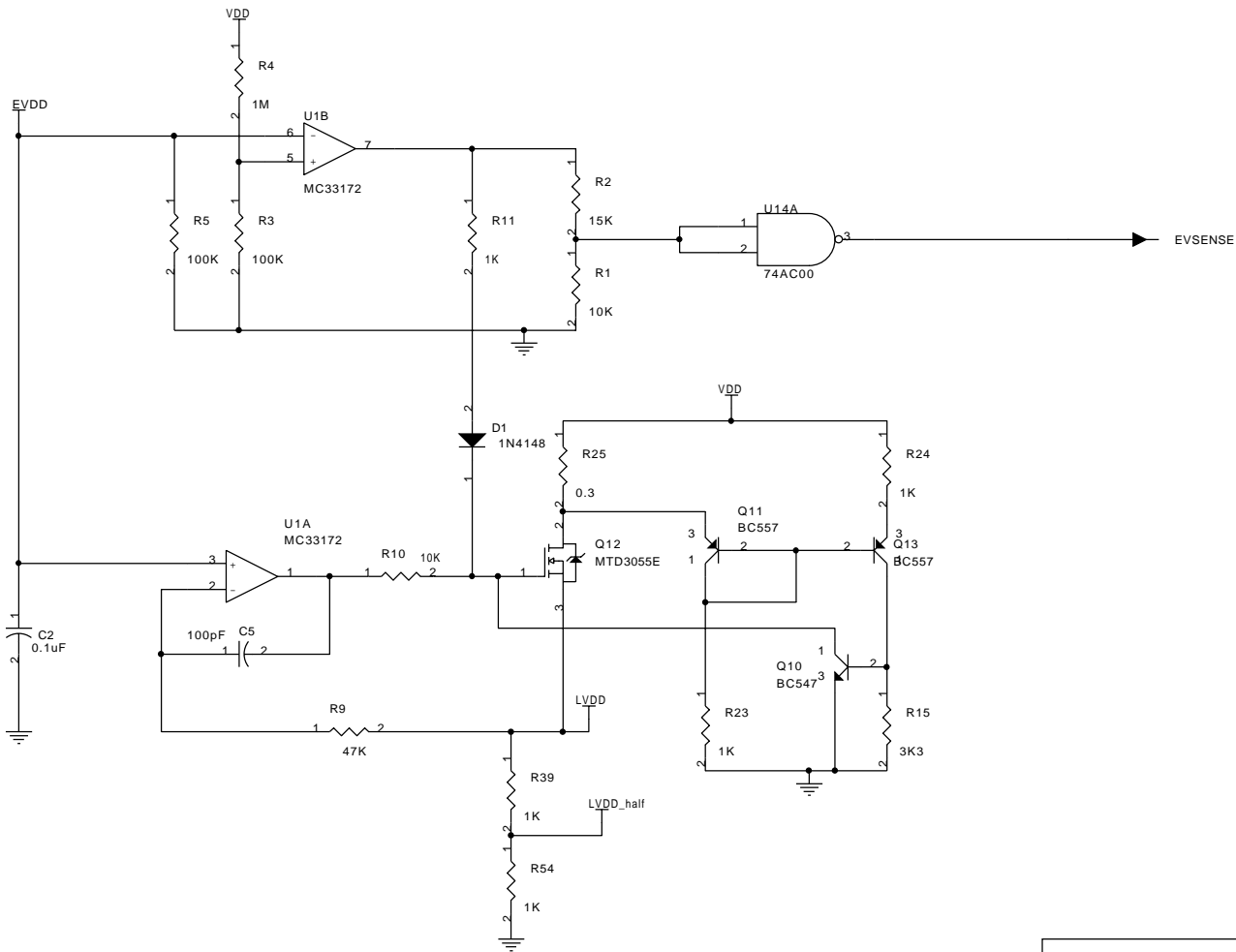

Motorola, Inc.				
Title M68EML08GP32 EMULATOR MODULE (Voltage regulator)				
Size B	Designed By: C.C. Poon	Approved By: Edward Chui	Rev F	
Date: Thursday, August 05, 1999	Sheet 17 of 17			

Index

C

cable assembly, target	30
configuration and operation	15
connector pin assignments	
logic analyzer (P1)	22
target (P5, P6)	25
connector signal descriptions	
target (P5)	26

E

EM layout	12
---------------------	----

I

installation, remaining system	19
--	----

J

Jumper header	
P3	16
jumper header	
positions	16
setting	16

M

MCU	
emulated	9
MMDS0508 (HC0508 Motorola Modular Development System)	
configuration and operation	15
MMDS0508 (HC0508 Motorola Modular Development System)	
description	10
MMEVS, description	11

P

pin assignments	
logic analyzer (P1)	22
target connectors (P5, P6).....	25

S

schematics.....	31
specifications.....	13
system components	
MMDS	10
MMEVS	10

Motorola reserves the right to make changes without further notice to any products herein. Motorola makes no warranty, representation or guarantee regarding the suitability of its products for any particular purpose, nor does Motorola assume any liability arising out of the application or use of any product or circuit, and specifically disclaims any and all liability, including without limitation consequential or incidental damages. "Typical" parameters which may be provided in Motorola data sheets and/or specifications can and do vary in different applications and actual performance may vary over time. All operating parameters, including "Typicals" must be validated for each customer application by customer's technical experts. Motorola does not convey any license under its patent rights nor the rights of others. Motorola products are not designed, intended, or authorized for use as components in systems intended for surgical implant into the body, or other applications intended to support or sustain life, or for any other application in which the failure of the Motorola product could create a situation where personal injury or death may occur. Should Buyer purchase or use Motorola products for any such unintended or unauthorized application, Buyer shall indemnify and hold Motorola and its officers, employees, subsidiaries, affiliates, and distributors harmless against all claims, costs, damages, and expenses, and reasonable attorney fees arising out of, directly or indirectly, any claim of personal injury or death associated with such unintended or unauthorized use, even if such claim alleges that Motorola was negligent regarding the design or manufacture of the part. Motorola and  are registered trademarks of Motorola, Inc. Motorola, Inc. is an Equal Opportunity/Affirmative Action Employer.

How to reach us:

USA/EUROPE/Locations Not Listed: Motorola Literature Distribution, P.O. Box 5405, Denver, Colorado 80217, 1-303-675-2140 or 1-800-441-2447. Customer Focus Center, 1-800-521-6274

JAPAN: Motorola Japan Ltd.; SPS, Technical Information Center, 3-20-1, Minami-Azabu, Minato-ku, Tokyo, 106-8573 Japan. 81-3-3440-8573

ASIA/PACIFIC: Motorola Semiconductors H.K. Ltd.; Silicon Harbour Centre, 2 Dai King Street, Tai Po Industrial Estate, Tai Po, N.T., Hong Kong. 852-26668334

Mfax™, Motorola Fax Back System: RMFAX0@email.sps.mot.com; <http://sps.motorola.com/mfax/>;
TOUCHTONE, 1-602-244-6609; US and Canada ONLY, 1-800-774-1848

HOME PAGE: <http://motorola.com/sps/>



MOTOROLA

© Motorola, Inc., 1999

EML08GP32UM/D