

# 68HC908JL/JK FAMILY

The Motorola 68HC908JL and 68HC908JK families provide designers with highly integrated cost-effective 8-bit FLASH microcontroller (MCU) solutions. The 68HC908JL and the 68HC908JK builds on the success of the 68HC05 family by offering a code compatible migration path to higher performance FLASH MCUs.

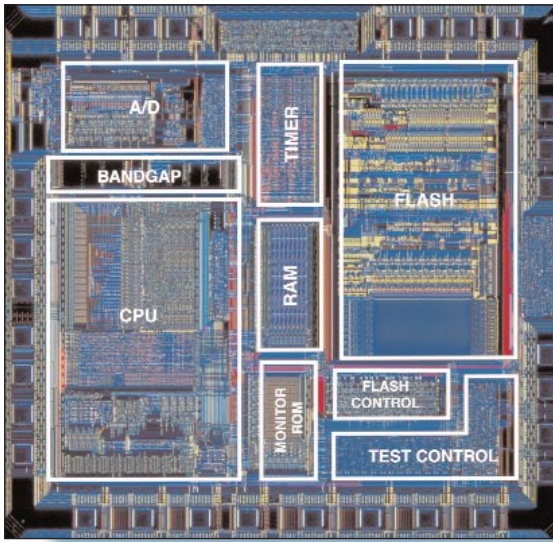

## Features

- In-system programmable FLASH memory
  - 68HC908JK1: 1536 bytes
  - 68HC908JL3/JK3: 4096 bytes
- FLASHwire technology – a single wire interface for in-circuit programming which does not require high voltage for mode entry
- Selectable FLASH security feature
- 128 bytes of user RAM
- 5 V nominal operating voltage
- 3 V low-power operating voltage
- High-performance 68HC08 CPU core
  - Code compatible with 68HC05
  - 8.0 MHz internal operating frequency at 5.0 V
- Peripheral modules
  - Computer Operating Properly (COP) watchdog
  - JK Family: 10-channel 8-bit analog-to-digital converter
  - JL Family: 12-channel 8-bit analog-to-digital converter
  - Dual-channel, 16-bit timer with input capture, output compare, and PWM modes
- Memory-mapped I/O registers
- Up to 23 bi-directional input/output (I/O) lines (JL family has 23 I/O; JK family has 15 I/O), including:
  - 10 mA sink/source capability on all I/O pins
  - 25 mA sink capability on two I/O pins
  - Software programmable pullups on nine I/O pins
  - Keyboard scan with selectable interrupts on seven I/O pins
  - Direct LED drives on ten I/O pins
- Internal pullups to  $V_{DD}$  on RESET and IRQ pins for reduced system cost
- Vectored interrupts
  - Selectable sensitivity on external interrupt (edge- and level-sensitive or edge-sensitive only)
  - External interrupt mask bit and acknowledge bit
- Illegal address reset
- Illegal opcode reset
- Low Voltage Inhibit with selectable trip points
- Multiple clock options
  - Crystal oscillator
  - Ceramic resonator
  - External clock
  - RC oscillator (68HRC908JL/JK)
- Bi-directional RESET pin
- Power-saving Stop and Wait modes
- Hyper-text linked databooks: MC68HC08JL3/H (ROM) and MC68HC908JL3/H (FLASH)
- Cost effective, full-featured development tools that support programming, in-circuit debug, simulation, and in-circuit emulation
- Package options
  - 68HC908JK: 20-pin DIP and 20-pin SOIC packages
  - 68HC908JL: 20-pin DIP and 28-pin SOIC packages

# 68HC908JL/JK

FAMILY

## DEVICE ORDERING INFORMATION

Production Order Part Number	Sample Order Part Number	Package Type	Oscillator Option	FLASH Size	Temperature Range
MC68HC908JL3CP	KMC908JL3CP	28 DIP	XTAL	4K	-40 to +85C
MC68HC908JL3CDW	KMC908JL3CDW	28 SOIC	XTAL	4K	-40 to +85C
MC68HC908JL3MP	NA	28 DIP	XTAL	4K	-40 to +125C
MC68HC908JL3MDW	NA	28 SOIC	XTAL	4K	-40 to +125C
MC68HRC908JL3CP	KMCR908JL3CP	28 DIP	RC	4K	-40 to +85C
MC68HRC908JL3CDW	KMCR908JL3CDW	28 SOIC	RC	4K	-40 to +85C
MC68HRC908JL3MP	NA	28 DIP	RC	4K	-40 to +125C
MC68HRC908JL3MDW	NA	28 SOIC	RC	4K	-40 to +125C
MC68HC908JK3CP	KMC908JK3CP	20 DIP	XTAL	4K	-40 to +85C
MC68HC908JK3CDW	KMC908JK3CDW	20 SOIC	XTAL	4K	-40 to +85C
MC68HC908JK3MP	NA	20 DIP	XTAL	4K	-40 to +125C
MC68HC908JK3MDW	NA	20 SOIC	XTAL	4K	-40 to +125C
MC68HRC908JK3CP	KMCR908JK3CP	20 DIP	RC	4K	-40 to +85C
MC68HRC908JK3CDW	KMCR908JK3CDW	20 SOIC	RC	4K	-40 to +85C
MC68HRC908JK3MP	NA	20 DIP	RC	4K	-40 to +125C
MC68HRC908JK3MDW	NA	20 SOIC	RC	4K	-40 to +125C
MC68HC908JK1CP*	KMC908JK1CP*	20 DIP	XTAL	1.5K	-40 to +85C
MC68HC908JK1CDW*	KMC908JK1CDW*	20 SOIC	XTAL	1.5K	-40 to +85C
MC68HRC908JK1CP*	KMCR908JK1CP*	20 DIP	RC	1.5K	-40 to +85C
MC68HRC908JK1CDW*	KMCR908JK1CDW*	20 SOIC	RC	1.5K	-40 to +85C

\* Available Q1 '00

## Application Notes

- AN1222/D Arithmetic Waveform Synthesis with 68HC05/68HC08 MCUs
- AN1221/D Hamming Error Control Coding Techniques with the 68HC08 MCU
- AN1219/D M68HC08 Integer Math Routines
- AN1218/D 68HC05 to 68HC08 Optimization
- AN-HK-33/H In-circuit programming of FLASH memory in the 68HC908JL3

## Comprehensive Development Support

Broad third party software and hardware support – see our web site at <http://www.mcu.motsp.com>

## EASY TO ORDER KITS

RESALE\*

M68ICS08JL	JL and JK Programmer/in-circuit debug kit	\$295
KITMMEVS08JL	Cost-effective real-time in-circuit emulator kit	\$1450
KITMMDS08JL	High performance real-time in-circuit emulator kit	\$3950

## INDIVIDUAL DEVELOPMENT TOOL COMPONENTS

RESALE\*

M68MMDS0508	High performance emulator	\$2950
M68MMPFB0508	MMEVS platform board	\$395
M68EML08GP32	Emulation module daughter board	\$495
M68CBL05C	Low noise flex-cable	\$120
M68TC08JK3P20	20-pin DIP target head adapter	\$50
M68TC08JL3P28	28-pin DIP target head adapter	\$50
M68DIP20SOIC	20-pin SOIC-DW target head adapter	\$35
M68DIP28SOIC	28-pin SOIC-DW target head adapter	\$35

\*All prices are manufacturer's suggested US resale.

©1999 Motorola, Inc. All rights reserved. Motorola is a registered trademark, and DigitalDNA and the DigitalDNA logo are trademarks of Motorola, Inc. All other trademarks are the property of their respective companies.

This product incorporates SuperFlash® technology licensed from SST.

 **DigitalDNA™**  
from Motorola