



**MOTOROLA**

Semiconductor Products Sector  
Technical Information

68HC908JL3MSE1

## Mask Set Errata 1

# 68H(R)C908JL3/JK3/JK1 8-Bit Microcontroller Unit

### INTRODUCTION

---

This mask set errata provides information pertaining to the glitch on timer buffered PWM output applicable to these 68H(R)C908JL3/JK3/JK1 MCU mask set devices:

- 2J88Y

### MCU DEVICE MASK SET IDENTIFICATION

---

The mask set is identified by a 5-character code consisting of a version number, a letter, two numerical digits, and a letter, for example 0XJ66D. Slight variations to the mask set identification code may result in an altered version number, for example 1XJ66D.

### MCU DEVICE DATE CODES

---

Device markings indicate the week of manufacture and the mask set used. The date is coded as four numerical digits where the first two digits indicate the year and the last two digits indicate the work week. For instance, the date code "9115" indicates the 15th week of the year 1991.

### MCU DEVICE PART NUMBER PREFIXES

---

Some MCU samples and devices are marked with an SC or XC prefix. An SC prefix denotes special/custom device. An XC prefix denotes that the device is tested but is not fully characterized or qualified over the full range of normal manufacturing process variations. After full characterization and qualification, devices will be marked with the MC prefix.

*When contacting a Motorola representative for assistance, please have the MCU device mask set and date code information available.*

Specifications and information herein are subject to change without notice.

## GLITCH ON TIMER BUFFERED PWM OUTPUT

In timer buffered PWM operation, when a timer overflow (TOF) event or an output compare (OC) event coincides with a write to either pair of the timer channel registers (TCHxH/L), the duty cycle at the PWM output glitches to 0% or 100% momentarily, then returns to proper operation.

To avoid the glitches when changing the PWM duty cycle, do not write to either pair of the timer channel registers at the TOF or OC.

For example, in the TOF interrupt service routine: If the OC occurs near the last TOF, write to the timer channel registers after the OC; if the OC occurs near the next TOF, write to the timer channel registers before the OC. A write to the channel register high byte (TCHxH) should immediately followed by a write to the low byte (TCHxL) to avoid TOF or OC occurring between the writes. Instruction cycle times must be included when making timing calculations.

The figure below shows a typical timer buffered PWM output waveform, indicating the TOF and OC events.

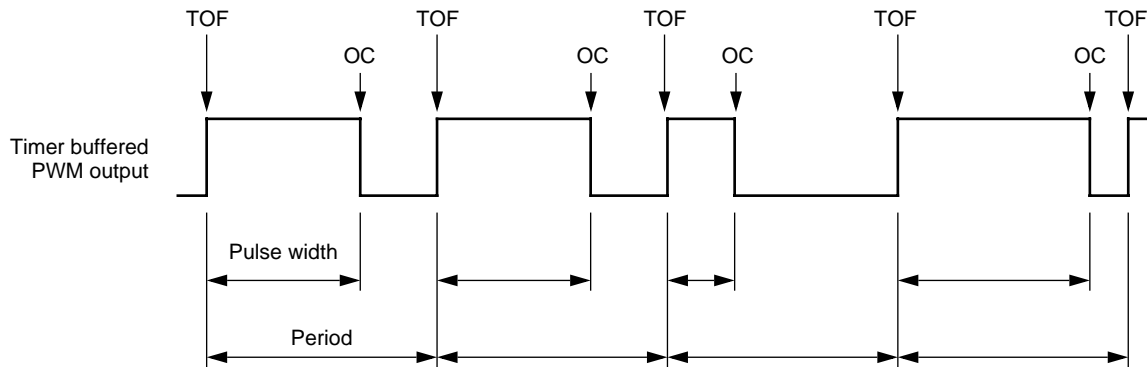

### NOTES:

Do not write to either pair of timer channel registers at:  
TOF (timer overflow), or  
OC (timer output compare) edges.

In buffered PWM, the pulse width is defined by the last written pair of timer channel registers.

Each pair of timer channel registers consist of a high byte register (TCHxH) and a low byte register (TCHxL).

Motorola reserves the right to make changes without further notice to any products herein. Motorola makes no warranty, representation or guarantee regarding the suitability of its products for any particular purpose, nor does Motorola assume any liability arising out of the application or use of any product or circuit, and specifically disclaims any and all liability, including without limitation consequential or incidental damages. "Typical" parameters which may be provided in Motorola data sheets and/or specifications can and do vary in different applications and actual performance may vary over time. All operating parameters, including "Typicals" must be validated for each customer application by customer's technical experts. Motorola does not convey any license under its patent rights nor the rights of others. Motorola products are not designed, intended, or authorized for use as components in systems intended for surgical implant into the body, or other applications intended to support or sustain life, or for any other application in which the failure of the Motorola product could create a situation where personal injury or death may occur. Should Buyer purchase or use Motorola products for any such unintended or unauthorized application, Buyer shall indemnify and hold Motorola and its officers, employees, subsidiaries, affiliates, and distributors harmless against all claims, costs, damages, and expenses, and reasonable attorney fees arising out of, directly or indirectly, any claim of personal injury or death associated with such unintended or unauthorized use, even if such claim alleges that Motorola was negligent regarding the design or manufacture of the part. Motorola and  are registered trademarks of Motorola, Inc. Motorola, Inc. is an Equal Opportunity/Affirmative Action Employer.

Additional mask set erratas can be found on the World Wide Web at <http://mcu.motps.com/documentation>



