

MOTOROLA

Automotive Selector Guide

Quarter 1, 2000

<http://sps.motorola.com/automotive>

Product information for:

8-Bit 68HC05, 68HC08, and 68HC11

16-Bit 68HC12 and 68HC16

32-Bit 683XX and Power PC

Automotive SMARTMOS™

Automotive Sensors

 **Digital DNA™**
from Motorola

- Visit <http://www.pemicro.com/ics08> for FREE windows-based development software, including simulators, assemblers, and debuggers for Motorola's HC08 Family of microcontrollers.
- Visit <http://www.mcu.motsp.com> to view Motorola's offering in technical support, including development tools, documentation, new searchable FAQ's, and freeware.
- Visit <http://www.mot-sps.com/products/microcontrollers/software> for information on Motorola OSEK products, including documentation, order information, and product support.
- In addition to the web downloadable development software, Motorola offers these 68HC908JL3/JK3 Development Kits:
 - M68ICS08JL Low-Cost Development Kit
 - KITMMEVS08JL Real-Time In-Circuit Emulator Kit
 - KITMMDS08JL High-Performance Emulator Kit

WHAT'S NEW!

Section	Description
Front Page	Addition of URL's and What's New Section
68HC05 Family	Upgrade of XC68HC05JJ6 to MC qualification status
	Upgrade of XC68HC05JP6 to MC qualification status
	Upgrade of XC68HC705P6A to MC qualification status
	Upgrade of XC68HC05V12 to MC qualification status
68HC08 Family	Addition of three new FLASH devices: MC68HC908JL3, MC68HC908JK3 and MC68HC908GP32
	Upgrade of XC68HC908AZ60 to MC qualification status
68HC12 Family	Removal of PC68HC12D60 device (project on hold until further notice)
	Upgrade of PC68HC912BC32 to XC qualification status
Schematics	Replacement of the Instrument Cluster System Example with a Body Controller Switching Example
	Revision of the Automotive Door System Example
	Replacement of the Engine Control System Example with a Gasoline Control System Example
Nomenclature	Addition of Device Numbering System for microcontrollers and pressure sensors

68HC05 Family (Sheet 1 of 3)

Device	ROM (Bytes)	RAM (Bytes)	OTP (Bytes)	EEPROM (Bytes)	Timer	I/O	Serial	MUX	A/D	PWM	COP	Pkg Option	Oper. Voltage (V)	Oper. Freq. (MHz)	Temp.	OTP	Avail.	Comments	Documentation
MC68HC705B16	—	352	14.8K	256	16-Bit 2 I/C, 2 O/C	32	SCI See comment	—	8-CH 8-Bit	2-CH 8-Bit	Y	52 PLCC(FN) 64 QFP(FU)	3.3, 5.0	—	C, V, M	—	Now	705B32 as OTP for SDIP	MC68HC05B6/D
MC68HC05B6	5.8K	176	—	256	16-Bit 2 I/C, 2 O/C	32	SCI See comment	—	8-CH 8-Bit	2-CH 8-Bit	Y	56 SDIP(B) 52 PLCC(FN) 64 QFP(FU)	3.3, 5.0	2.1	C, V, M	705B16 705B32	Now	SCI has synchronous master SPI like capability	MC68HC05B6/D
MC68HC05B8	7K	176	—	256	16-Bit 2 I/C, 2 O/C	32	SCI See comment	—	8-CH 8-Bit	2-CH 8-Bit	Y	56 SDIP(B) 52 PLCC(FN) 64 QFP(FU)	3.3, 5.0	2.1	C, V	705B16 705B32	Now	SCI has synchronous master SPI like capability	MC68HC05B6/D
MC68HC05B16	14.75K	352	—	256	16-Bit 2 I/C, 2 O/C	32	SCI See comment	—	8-CH 8-Bit	2-CH 8-Bit	Y	56 SDIP(B) 52 PLCC(FN) 64 QFP(FU)	3.3, 5.0	2.1	C, V, M	705B16 See comment	Now	SCI has synchronous master SPI like capability	MC68HC05B6/D
XC68HC705B32	—	528	32K	256	16-Bit 2 I/C, 2 O/C	32	SCI See comment	—	8-CH 8-Bit	2-CH 8-Bit	Y	56 SDIP(B) 52 PLCC(FN) 64 QFP(FU)	3.3, 5.0	—	C	—	Limited	SCI has synchronous master SPI like capability	MC68HC05B6/D
XC68HC05B32	30.5K	528	—	256	16-Bit 2 I/C, 2 O/C	32	SCI See comment	—	8-CH 8-Bit	2-CH 8-Bit	Y	56 SDIP(B) 52 PLCC(FN) 64 QFP(FU)	3.3, 5.0	2.1	See comments	705B32	Limited	SCI has synchronous master SPI like capability 0–70°C temp. only for SDIP; –40 to +85 for PLCC/QFP	MC68HC05B6/D
MC68HC705C8A	—	304	8K	—	16-Bit 1 I/C, 1 O/C	31	SCI & SPI	—	—	—	Y	40 DIP(P) 42 SDIP(B) 44 PLCC(FN) 44 QFP(FB)	3.3, 5.0	—	C, V, M	—	Now	High-speed option available, order as MC68HSC705C8A	MC68HC705C8A/D
MC68HC05C4A	4K	176	—	—	16-Bit 1 I/C, 1 O/C	31	SCI & SPI	—	—	—	Y	40 DIP(P) 42 SDIP(B) 44 PLCC(FN) 44 QFP(FB)	3.0, 5.0	2.1	C, V, M	705C8A	Now	High-speed select on RVU header, low-voltage 2.4V to 3.6V @ 1MHz, bus available	HC05C4AGRS/D
MC68HC05C8A	8K	176	—	—	16-Bit 1 I/C, 1 O/C	31	SCI & SPI	—	—	—	Y	40 DIP(P) 42 SDIP(B) 44 PLCC(FN) 44 QFP(FB)	3.3, 5.0	2.1	C, V, M	705C8A	Now	High-speed select on RVU header, low-voltage 2.4V to 3.6V @ 1MHz, bus available	HC05C8AGRS/D
MC68HC705C9A	—	352	16K	—	16-Bit 1 I/C, 1 O/C	31	SCI & SPI	—	—	—	Y	40 DIP(P) 42 SDIP(B) 44 PLCC(FN) 44 QFP(FB)	3.3, 5.0	—	C	—	Now	'A' features	HC705C9AGRS/D
MC68HC05C9A	16K	352	—	—	16-Bit 1 I/C, 1 O/C	31	SCI & SPI	—	—	—	Y	40 DIP(P) 42 SDIP(B) 44 PLCC(FN) 44 QFP(FB)	3.0, 5.0	2.1	C, V, M	705C9A	Now	High speed available, see RVU header	HC05C9AGRS/D
MC68HC705E6	—	128	6K	160	16 Bit 1 I/C, 2 O/C MFT, RTI	36	—	—	4-CH 8-Bit	—	Y	28 SOIC(DW) 44 QFP(FB)	—	—	C	—	Now	Keyboard interrupt, LVI	MC68HC05E6/D

68HC05 Family (Sheet 2 of 3)

Device	ROM (Bytes)	RAM (Bytes)	OTP (Bytes)	EEPROM (Bytes)	Timer	I/O	Serial	MUX	A/D	PWM	COP	Pkg Option	Oper. Voltage (V)	Oper. Freq. (MHz)	Temp.	OTP	Avail.	Comments	Documentation
MC68HC05E6	5.9K	128	—	WR160	16-Bit 1I/C, 1O/C MFT, RTI	36	—	—	4-CH 8-Bit	—	Y	28SOIC(DW) 44QFP(FB)	—	2.1	C	705E6	Now	Keyboard interrupt, LVI	MC68HC05E6/D
MC68HC05E16	15.9K	352	—	320	16-Bit 2I/C, 2O/C MFT, RTI	47+2	I ² C	—	2-CH 8-Bit	—	Y	64 QFP(FU) 44 QFP(FB) 56 SDIP(B)	—	2.1	C	Contact factory	Now	PLL, RTI, keyboard interrupt	MC68HC05E16/D
XC68HC705E24	—	352	23.5K	320	16-Bit 2I/C, 2O/C MFT, RTI	47+2	I ² C	—	2-CH 8-Bit	—	Y	64 QFP(FU) 44 QFP(FB)	—	—	C	—	Now		Contact sales
XC68HC705H12	—	256	12K	256	2x 16-Bit 2 I/C, 2O/C	32	SPI SCI	—	4-CH 8-Bit	8-CH 8-Bit	Y	52 PLCC(FN)	5.0	—	C	—	Now	Power drivers for two major and four minor gauges	HC05H12GRS/D
XC68HC05H12	12K	256	—	256	2x 16-Bit 2 I/C, 2O/C	32	SPI SCI	—	4-CH 8-Bit	8-CH 8-Bit	Y	52 PLCC	5.0	2.1	C	705H12	Now	Power drivers for two major and four minor gauges	HC05H12GRS/D
MC68HC705J1A	—	64	1.2K	—	MFT, RTI	14	—	—	—	—	Y	20 DIP(P) 20 SOIC(DW)	3.3, 5.0	—	C, V	—	Now	RC option now available, see comments	MC68HC705J1A/D
MC68HC05J1A	1.2K	64	—	—	MFT, RTI	14	—	—	—	—	Y	20 DIP(P) 20 SOIC(DW)	2.0, 3.3, 5.0	2.1	C, V	705J1A	Now	Keyboard scan, mask selectable pulldowns/interrupt on I/O low voltage 1.8V	MC68HC05J1A/D MC68HC05J1AAD/D
XC68HC705JJ7	—	224	6K+ 64 Bit PEP	—	16-Bit 1I/C, 1O/C MFT, RTI	14	SIOP	—	4-CH 12-Bit	—	Y	20 DIP(P) 20 SOIC(DW)	3.3, 5.0	—	C	—	Now		HC705JJ7GRS/D
MC68HC05JJ6	6K	224	—	—	16-Bit 1I/C, 1O/C MFT, RTI	14	SIOP	—	4-CH 12-Bit	—	Y	20 DIP(P) 20 SOIC(DW)	3.3, 5.0	2.1	C	705JJ7	Now		HC05JJ6GRS/D
MC68HC705JP7	—	224	6K+ 64 Bit PEP	—	16-Bit 1I/C, 1O/C MFT, RTI	22	SIOP	—	4-CH 12-Bit	—	Y	28 DIP(P) 28 SOIC(DW)	3.3, 5.0	—	C	—	Now		HC705JJ7GRS/D
XC68HC05JP6	6K	224	—	—	16-Bit 1I/C, 1O/C MFT, RTI	22	SIOP	—	4-CH 12-Bit	—	Y	28 DIP(P) 28 SOIC(DW)	3.3, 5.0	2.1	C	705JP7	Now		HC05JJ6GRS/D
MC68HC05K0	0.5K	32	—	—	MFT, RTI	10	—	—	—	—	Y	16 DIP(P) 16 SOIC(DW)	2.1, 3.0, 3.3, 5.0	2.1	C	705K1 805K3	Now	Low voltage 1.8V high-speed option, see RVU header	MC68HC05K1/D
XC68HC805K3	—	64	920 EEPROM	920 + 16 PEEP	MFT, RTI	10	—	—	—	—	Y	16 DIP(P) 16 SOIC(DW)	3.3,5.0	—	C	—	Now	FLASH-like emulator	HC805K3GRS/D
MC68HC05K3	0.9K	64	—	16 PEEP	MFT, RTI	10	—	—	—	—	Y	16 DIP(P) 16 SOIC(DW) 20 SSOP(SD)	3.3,5.0	2.1	C	805K3	Now	Personality EEPROM RTI, keyboard scan Low power 2.5V 0.7V @ 0.5 MHz bus	MC68HC05K3/D
MC68HC705KJ1	—	64	1.2K	—	MFT, RTI	10	—	—	—	—	Y	16 DIP(P) 16 SOIC(DW) 16 Cerdip(S)	3.3,5.0	—	C	—	Now	Very low cost OTP, windowed ceramic DIP package available (S)	MC68HC705KJ1/D

68HC05 Family (Sheet 3 of 3)

Device	ROM (Bytes)	RAM (Bytes)	OTP (Bytes)	EEPROM (Bytes)	Timer	I/O	Serial	MUX	A/D	PWM	COP	Pkg Option	Oper. Voltage (V)	Oper. Freq. (MHz)	Temp.	OTP	Avail.	Comments	Documentation
MC68HC05P1A	2K	128	—	—	16-Bit 1 I/C, 1 O/C	21	—	—	—	—	Y	28 DIP(P) 28 SOIC(DW)	3.3, 5.0	2.1	C, V	705P6A	Now	Keyboard inter- rupts, pullups, high -current drive, no ROM Security	HC05P1AGRS/D
MC68HC705P6A	—	176	4.5K	—	16-Bit 1 I/C, 1 O/C	21	SIOP	—	4-CH 8-Bit	—	Y	28 DIP(P) 28 SOIC(DW)	3.3, 5.0	—	C	—	Now	Umbrella OTP for P1A, P4A, and P9A	HC705P6AGRS/D
MC68HC05P6	4.5K	176	—	—	16-Bit 1 I/C, 1 O/C	21	SIOP	—	4-CH 8-Bit	—	Y	28 DIP(P) 28 SOIC(DW)	3.3, 5.0	2.1	C, V, M	705P6A	Now		MC68HC05P6/D MC68HC05P6AD/D
XC68HC805P18	—	192	—	8K +128	16 Bit 1 I/C, 1 O/C	20	SIOP	—	4-CH 8-Bit	—	Y	28 DIP(P) 28 SOIC(DW)	—	—	C, V, M	—	Now		HC805P18GRS/D
XC68HC05P18	8K	192	—	128	16 Bit 1 I/C, 1 O/C	20	SIOP	—	4-CH 8-Bit	—	Y	28 DIP(P) 28 SOIC(DW)	5.0	21	C, V, M	805P18	Now		HC05P18GRS/D
MC68HC805PV8	—	192	8K EEPROM	128	15-Bit 16-bit 2i/C, 2O/C	20	—	—	6-CH 8-Bit	1	Y	28 SOIC(DW)	—	—	—	—	4Q 98	4.2 MHz high speed available	Contact sales
PC68HC05PV8	8K	192	—	128	15-Bit 16-bit 2i/C, 2O/C	20	—	—	6-CH 8-Bit	1	Y	28 SOIC(DW)	—	2.1	—	805PV8	1Q 99		Contact sales
XC68HC705V8	—	512	12K	128	16-Bit	22	SPI	J1850	16-CH 8-Bit	1-CH 6-Bit	Y	56 SDIP(B) 68 PLCC(FN) 64 QFP(FU)	—	—	—	N/A	Now	System chip volt- age regulator and transceiver	HC705V8GRS/D
XC68HC05V7	10K	386	—	128	16-Bit	22	SPI	J1850	16-CH 8-Bit	1-CH 6-Bit	Y	56 SDIP(B) 68 PLCC(FN)	—	2.1	—	705V8	Now	System chip volt- age regulator and transceiver	HC05V7GRS/D
XC68HC705V12	—	384	12K	256	16-Bit 1 I/C, 1 O/C 8-bit, RTI	23	SPI	J1850	5 CH 8-Bit	2-CH 6-Bit	Y	68 PLCC (FN)	—	—	C, V, M	—	Now	Bridge drivers for 6 gauges: 4 minor – 180° 2 major – 360°	HC705V12GRS/D
MC68HC05V12	12k	384	—	256	16-Bit 1 I/C, 1 O/C 8-bit, RTI	23	SPI	J1850	5 CH 8-Bit	2-CH 6-Bit	Y	68 PLCC (FN)	—	—	C, V, M	705V12	Now	Bridge drivers for 6 gauges: 4 minor – 180° 2 major – 360°	HC05V12GRS/D
XC68HC705X4	—	176	4K	—	16-Bit 1I/C, 1O/C	16	—	CAN	—	—	Y	28 SOIC(DW)	—	2.1	C, V, M	—	Now	2MHz bus speed only	MC68HC05X4/D
MC68HC05X4	4K	176	—	—	16-Bit 1I/C, 1O/C MFI, RTI	16	—	CAN	—	—	Y	28 SOIC(DW)	5.0	2.1	C	705X4 (limited)	Now	2MHz bus speed only	MC68HC05X4/D
MC68HC705X32	—	528	32K	256	16-Bit 2I/C, 2O/C	32	SCI	CAN	8-CH 8-Bit	2-CH 8-Bit	Y	64 QFP(FU)	—	—	C, V, M	—	Now	4MHz bus speed available	MC68HC05X16/D
MC68HC05X16	14.75K	352	—	256	16-Bit 2I/C, 2O/C	32	SCI	CAN	8-CH 8-Bit	2-CH 8-Bit	Y	64 QFP(FU)	—	2.1	C, V, M	705X32	Now	2MHz bus speed only	MC68HC05X16/D
MC68HC05X32	—	528	32K	256	16-Bit 2I/C, 2O/C	32	SCI	CAN	8-CH 8-Bit	2-CH 8-Bit	Y	64 QFP(FU)	5.0	2.1	C, V, M	—	Now	4MHz bus speed available	MC68HC05X16/D

68HC05 Reference Manual

M68HC05AG/AD
M68HC05TB/D

Applications Guide
Understanding Small Microcontrollers Text Book

68HC08 Family

68HC08 Family

Device	ROM (Bytes)	RAM (Bytes)	OTP (Bytes)	EEPROM (Bytes)	Timer	I/O	Serial	MUX	A/D	PWM	COP	Pkg Option	Oper. Voltage (V)	Oper. Freq. (MHz)	Temp.	OTP	Avail.	Comments	Documentation
XC68HC908AS60	—	2K	60K FLASH	1K	6-CH	40/46	SCI SPI	J1850 (VPW)	15-CH 8-Bit	—	Y	52 PLCC(FN) 64 QFP(FU)	—	—	C	—	Now	On-chip charge pump for FLASH memory	Contact sales
XC68HC08AS20	20K	768	—	512	6-CH	40/46	SCI SPI	J1850 (VPW)	15-CH 8-Bit	—	Y	52 PLCC(FN)	5.0	8.0 Max.	C	908AS60	Now		MC68HC08AS20/D
XC68HC08AS32	32K	1024	—	512	6-CH	40/46	SCI SPI	J1850	8-CH 8-Bit	—	Y	52 PLCC(FN)	5.0	8.0 Max.	C, V	908AS60	Now		MC68HC08AS32/D
MC68HC908AZ60	—	2K	60K FLASH	1K	6-CH + 2-CH 16-Bit, 8 I/C, O/C, OR PWM	48	SCI SPI	CAN 2.0a/2.0b	15-CH 8-Bit	—	Y	64 QFP(FU)	5.0	8.0 Max.	C, V, M	—	Now	On-chip charge pump for FLASH memory	HC908AZ60GRS/D
XC68HC08AZ32	32K	1K	—	512	4-CH + 2-CH 16-Bit, I/C, O/C, OR PWM	48	SCI SPI	CAN 2.0a/2.0b	8-CH 8-Bit	—	Y	64 QFP(FU) 100 QFP(FU)	5.0	8.0 Max.	C, M, V	908AZ60	Now		HC08AZ32TS/D
XC68HC08AZ60	60K	2K	—	1K	6-CH + 2-CH 16-Bit, 8 I/C, O/C, OR PWM	48	SCI SPI	CAN 2.0a/2.0b	15-CH 8-Bit	—	Y	64 QFP(FU)	—	—	V	908AZ60	Now		Contact sales
XC68HC908GP20	—	512	20K FLASH	—	DUAL 16-Bit 2-CH IC, OC, or PWM	33	SCI SPI	—	8-CH 8-Bit	—	Y	40 DIP(P) 44 QFP(FB)	3.0, 5.0	8.0 Max.	C	—	Now		MC68HC908GP20/D
MC68HC908GP32	—	512	32K FLASH	—	Dual 2-CH 16-Bit IC, OC, or PWM	33	SCI SPI	—	8-CH 8-Bit	See Timer	Y	40 DIP(P) 44 QFP(FB) 42 SDIP(B)	3.0, 5.0	8.0 Max.	C	—	Now	32 kHz PLL, time-base module, low-voltage inhibit with selectable trip points	MC68HC908GP32/H
MC68HC908JL3	—	128	4K FLASH	—	2-CH 16 Bit IC, OC, or PWM	23	—	—	12-CH 8-Bit	See Timer	Y	28 DIP(P) 28 SOIC(DW)	3.0, 5.0	8.0 Max.	C	—	Now	RC oscillator option, LVR with selectable trip points, 6 pin LED drive	MC68HC08JL3/H
MC68HC908JK3	—	128	4K FLASH	—	2-CH 16 Bit IC, OC, or PWM	15	—	—	10-CH 8-Bit	See Timer	Y	20 DIP(P) 20 SOIC(DW)	3.0, 5.0	8.0 Max.	C	—	Now	RC oscillator option, LVR with selectable trip points, 6 pin LED drive	MC68HC08JL3/H
XC68HC708MP16	—	512	16	—	2-CH, 16-Bit	4-CH, 16-Bit	44	—	SPI SCI	—	Y	64 QFP(FU)	—	—	C	—	Now	PWM for 3 phase motor control	HC708MP16GRS/D
PC68HC908RK2	—	128	2K FLASH	—	2-CH, 16-Bit	14	—	—	—	—	Y	20 SOIC(DW) 20 SSOP(SD)	1.8 to 3.6	4.0 Max.	C	—	Now	Low power embedded FLASH routine	MC68HC908RK2/D
PC68HC908RFRK2	—	128	2K FLASH	—	1-CH, 16-Bit	12	—	—	—	—	Y	32 LQFP(FA)	1.8 to 3.6	4.0 Max.	C	—	Now	RF transmitter integrated	Contact sales

68HC08 Reference Manual

CPU08RM/AD
TIM08RM/AD

CPU Reference Manual
Timer Reference Manual

68HC11 Family (Sheet 1 of 2)

Device	ROM (Bytes)	RAM (Bytes)	OTP (Bytes)	EEPROM (Bytes)	Timer	I/O S. C.	I/O EXP	Serial	A/D	PWM	Package Options	Temp.	OTP	Maximum Bus Speed (MHz)	Comments	Documentation
MC68HC11D0	—	192	—	—	16-bit, 3/4IC, 4/5OC, RTI, pulse accumulator, watchdog	32	16	SPI SCI	—	—	40 PDIP 44 QFP 44 PLCC	C, V, M	—	3	64K external address bus, low-voltage version available	MC68HC11D3/D
MC68HC711D3	—	192	4K	—	16-bit, 3/4IC, 4/5OC, RTI, pulse accumulator, watchdog	32	16	SPI SCI	—	—	40 PDIP 44 PLCC 44 QFP 44 CLCC	C, V, M	—	3	64K external address bus, 3MHz, C temperature	MC68HC711D3/D
MC68HC11D3	4K	192	—	—	16-bit, 3/4IC, 4/5OC, RTI, pulse accumulator, watchdog	32	16	SPI SCI	—	—	40 PDIP 44 QFP 44 PLCC	C, V, M	711D3	3	64K external address bus	MC68HC11D3/D
MC68HC811E2	—	256	—	2048	16-bit, 3IC, 4OC, RTI, pulse accumulator	38	32	SPI SCI	8-CH 8-Bit	—	52 PLCC 52 LQFP	C, V, M	—	2	Secure device available, EEPROM block protect	MC68HC11E/D
MC68HC711E9	—	512	12K	512	16-bit, 3/4IC, 4/5OC, RTI, pulse accumulator	38	22	SPI SCI	8-CH 8-Bit	—	52 PLCC 52 CLCC 64 QFP	C, V, M	—	3	EEPROM block protect 4MHz available contact factory	MC68HC11E/D
MC68HC11E0	—	512	—	—	16-bit, 3/4IC, 4/5OC, RTI, pulse accumulator	38	22	SPI SCI	8-CH 8-Bit	—	52 PLCC 64 QFP 52 LQFP	C, V, M	711E9	3	Low-voltage parts available, 2MHz, -20 to 70°C	MC68HC11E/D
MC68HC11E1	—	512	—	512	16-bit, 3/4IC, 4/5OC, RTI, pulse accumulator	22	22	SPI SCI	8-CH 8-Bit	—	52 PLCC 64 QFP 52 LQFP	C, V, M	711E9	3	Low-voltage parts available, 2MHz, -20 to 70°C	MC68HC11E/D
MC68HC11E9	12K	512	—	512	16-bit, 3/4IC, 4/5OC, RTI, pulse accumulator	38	22	SPI SCI	8-CH 8-Bit	—	52 PLCC 64 QFP 52 LQFP	C, V, M	711E9	3	Low-voltage parts available, 2MHz, -20 to 70°C 4MHz available contact factor	MC68HC11E/D
MC68HC711E20	—	768	20K	512	16-bit, 3/4IC, 4/5OC, RTI, pulse accumulator	38	22	SPI SCI+	8-CH 8-Bit	—	52 PLCC 64 QFP 52 CLCC	C, V, M	—	4	4MHz available contact factory	MC68HC11E/D
MC68HC11E20	20K	768	—	512	16-bit, 3/4IC, 4/5OC, RTI, pulse accumulator	38	22	SPI SCI+	8-CH 8-Bit	—	52 PLCC 64 QFP 52 CLCC	C, V, M	711E20	3	4MHz available contact factory	MC68HC11E/D
MC68HC11F1	—	1K	—	512	16-bit, 3/4IC, 4/5OC, WDOG, RTI, pulse accumulator	30	30	SPI SCI	8-CH 8-Bit	—	68 PLCC 80 LQFP	C, V, M	—	5	64K external address bus, 4 programmable chip selects, 4MHz non-mux address/data bus, low-voltage version	MC68HC11F1/D
MC68HC11FC0	—	1K	—	—	6-bit, 3/4IC, 4/5OC, WDOG, RTI, pulse accumulator	—	30	SPI SCI	—	—	80 LQFP 64 QFP	0-70 °C	—	5, 6	64K external address bus, 4 programmable chip selects, extra pair of power/GND pins	MC68HC11FTS/D
MC68HC11K0	—	768	—	—	16-bit, 3/4IC, 4/5OC, RTI, pulse accumulator	62	37	SPI SCI+	8-CH 8-Bit	4-CH 8-Bit or 2-CH 16-Bit	84 PLCC 80 QFP	C, V, M	—	3, 5	5MHz non-mux bus, extended memory map, 4 chip selects.	MC68HC11K4/D

68HC11 Family (Sheet 2 of 2)

Device	ROM (Bytes)	RAM (Bytes)	OTP (Bytes)	EEPROM (Bytes)	Timer	I/O S. C.	I/O EXP	Serial	A/D	PWM	Package Options	Temp.	OTP	Maximum Bus Speed (MHz)	Comments	Documentation
MC68HC11K1	—	768	—	640	16-bit, 3/4IC, 4/5OC, RTI, pulse accumulator	62	37	SPI SCI+	8-CH 8-Bit	4-CH 8-Bit or 2-CH 16-Bit	84 PLCC 80 QFP	C, V, M	—	5	5MHz non-mux bus, extended memory map, 4 chip selects	MC68HC11K4/D
MC68HC711K4	—	768	24K	640	16-bit, 3/4IC, 4/5OC, RTI, pulse accumulator	62	37	SPI SCI+	8-CH 8-Bit	4-CH 8-Bit or 2-CH 16-Bit	84 PLCC 80 QFP	C, V, M	—	4, 5	4MHz non-mux bus, extended memory map, 4 chip selects	MC68HC11K4/D
MC68HC11K4	24K	768	—	640	16-bit, 3/4IC, 4/5OC, RTI, pulse accumulator	62	37	SPI SCI+	8-CH 8-Bit	4-CH 8-Bit or 2-CH 16-Bit	84 PLCC 80 QFP	C, V, M	711K4 (limited)	5	5MHz non-mux bus, extended memory map, 4 chip selects	MC68HC11K4/D
MC68HC711KS2	—	1K	32K	640	16-bit, 3/4IC, 4/5OC, RTI, pulse accumulator	51	26	SPI+ SCI+	8-CH 8-Bit	4-CH 8-Bit or 2-CH 16-Bit	68 PLCC 80 LQFP	C, V, M	—	4	4MHz non-mux bus, no MMU, no chip selects, low-power mode, security option available	MC68HC11K/D
MC68HC11KS2	32K	1K	—	640	16-bit, 3/4IC, 4/5OC, RTI, pulse accumulator	51	26	SPI+ SCI+	8-CH 8-Bit	4-CH 8-Bit or 2-CH 16-Bit	68 PLCC 80 LQFP	C, V, M	711KS2	4	4MHz non-mux bus, no MMU, no chip selects, low-power mode, security option available	MC68HC11K/D
MC68HC11KW1	—	768	—	640	16-bit, 3/4IC, 4/5OC, RTI, pulse accumulator	80	55	SPI+ SCI+	10-CH 10-Bit	4-CH 8-BIT	100 LQFP	C	—	4	4MHz non-mux bus, 2 extra timers, 4 chip selects, extended memory map	MC68HC11KW1/D
MC68HC711P2	—	1K	32K	640	16-bit, 3/4IC, 4/5OC, RTI, pulse accumulator	62	37	Triple SPI SCI	8-CH 8-Bit	4-CH 8-Bit	84 PLCC	C	qQ	4	64K external address bus, M1-bus interface, PLL clock circuitry	MC68HC11P2/D
MC68HC11P2	32K	1K	—	640	16-bit, 3/4IC, 4/5OC, RTI, pulse accumulator	62	37	Triple SPI SCI	8-CH 8-Bit	4-CH 8-Bit or 2-CH 16-Bit	84 PLCC	C	711P2 (limited)	4	64K external address bus, M1-bus interface, PLL clock circuitry	MC68HC11P2/D

68HC11 Reference Manual

68HC12 Family

Device	ROM (Bytes)	RAM (Bytes)	OTP (Bytes)	EEPROM (Bytes)	Timer	I/O S. C.	I/O EXP	Serial	MUX	A/D	PWM	Package Options	Temp.	OTP	Maximum Bus Speed (MHz)	Comments	Documentation
MC68HC812A4	—	1K	—	4K	8-CH, 16-bit	Up to 91		2 SCI 1 SPI	—	8-CH 8-Bit	—	112 LQFP 100 LQFP	C	—	8 5	PLL non-muxed bus, BDM	MC68HC812A4TS/D
XC68HC912B32	—	1K	32K FLASH	768	8-CH, 16-bit	Up to 63		1 SCI 1 SPI	J1850	8-CH 8-Bit	4-CH 8-Bit or 2-CH 16-Bit	80 QFP	C	—	8	Limited availability until 4Q99, J1850 muxed bus, BDM	MC68HC912B32/D
XC68HC912BC32	—	1K	32K FLASH	768	8-CH, 16-bit	Up to 63		1 SCI 1 SPI	CAN 2.0a CAN 2.0b	8-CH 10-Bit	4-CH 8-Bit or 2-CH 16-Bit	80 QFP	C	—	8	Limited availability until 4Q99, MSCAN module on board, BDM	MC68HC912B32TS/D
PC68HC12BC32	32K	1K	—	768	8-CH, 16-bit	Up to 64		1 SCI 1 SPI	CAN 2.0b	8-CH 8-Bit	4-CH 8-Bit	80 QFP	C, V, M ⁽¹⁾	HC912BC32	8		Contact sales
XC68HC912D60	—	2K	60K FLASH	1K	8-CH, 16-bit buffered input captures (ECT)	Up to 66, plus up to 18 input only lines		2 SCI 1 SPI	CAN 2.0b	2 x 8-CH 10-Bit ⁽²⁾	4-CH 8-Bit or 2-CH 16-Bit	80 QFP ⁽²⁾ 112 LQFP	C, V, M ⁽¹⁾	—	8	Limited availability until 4Q99, PLL, MSCAN module on board, BDM	MC68HC912D60/D
XC68HC912DG128	—	8K	128K FLASH	2K	8-CH, 16-bit buffered input captures (ECT)	Up to 68, plus up to 18 input only lines		2 SCI 1 SPI	2 X CAN 2.0b	2 x 8-CH 10-Bit	4-CH 8-Bit or 2-CH 16-Bit	112 LQFP	C	—	8	Limited availability until 4Q99, PLL, MSCAN module on board, BDM	MC68HC912DG128/D
XC68HC12DG128	128K	8K	—	2K	8-CH, 16-bit buffered input captures (ECT)	Up to 68, plus up to 18 input only lines		2 SCI 1 SPI	2 X CAN 2.0b	2 x 8-CH 10-Bit	4-CH 8-Bit or 2-CH 16-Bit	112 LQFP	C	HC912DG128	8		Contact sales

1. M temperature range limited to single-chip mode
2. 1 x 8-CH 10-bit ATD in 80 QFP option

68HC12 Reference Manual

68HC12 Reference Manual CPU12RM/AD

68HC16 Family

68HC16 Family

Device	ROM (Bytes)	RAM (Bytes)	FLASH (Kbytes)	Device Integration	Timers	Serial Communication	Analog	Package Options	Operating Voltage (V)	Operating Frequency (MHz)	Temperature	OTP	Documentation
XC68HC916Y1	0	2K+2K	48 + 2	SCIM	GPT+TPU	MCCI	ADC	160 QFP	5.0	16	C	—	MC68HC16Y1UM/AD
MC68HC16Y1	48K	2K	0	SCIM	GPT+TPU	MCCI	ADC	160 QFP	5.0	16	C, V, M	HC916Y1	MC68HC16Y1UM/AD
MC68HC916Y3	0	4K	96+4	SCIM2	GPT+TPU2	QSM MCCI	ADC	160 QFP	5.0	16	C	—	MC68HC16Y3PP/D (MC68HC16Y3/916Y3UM/AD on web only)
MC68HC16Y3	96K	4K	0	SCIM2	GPT+TPU2	QSM MCCI	ADC	160 QFP	5.0	16	C, V, M	HC916Y3	MC68HC16Y3PP/D (MC68HC16Y3/916Y3UM/AD on web only)
MC68HC916Y5	0	4K	160	SLIM+ACS	TPU2+CTM3	RSPI MCCI	QADC	160 QFP	5.0	20	C, V	—	Contact sales
MC68HC16Y5	160K	4K	0	SLIM+ACS	TPU2+CTM3	RSPI MCCI	QADC	160 QFP	5.0	20	C, V	HC916Y5	Contact sales
MC68HC16Z3	8K	4K	0	SIM	GPT	QSM	ADC	132 PQFP 144 LQFP	5.0	16, 20, 25	C, V, M	—	MC68HC16ZUM/AD

68HC16 Reference Manuals

CPU16RM/AD	68HC16 CPU Reference Manual
SIMRM/AD	System Integration Module Reference Manual
TPURM/AD	TPU Reference Manual
GPTRM/AD	General-Purpose Timer Reference Manual
QSMRM/AD	Queued Serial Module Reference Manual
ADCRM/AD	Analog-to-Digital Reference Manual
CTMRM/D	Configurable Timer Reference Manual
MCCIRM/AD	Multi-Channel Communication Interface Reference Manual
SCIMRM/AD	Single-Chip Integration Module Reference Manual

683XX Family

Device	ROM (Kbytes)	RAM (Bytes)	FLASH (Kbytes)	Device Integration	Timer	Serial	A/D	PWM	I/O	COP	Operating Voltage	Temperature	Operating Frequency	Package Options	Comments	Documentation
MC68332	0	2K	0	SIM	TPU	QSM	—	—	—	—	5.0	C, V, M	16, 20, 25	132 PQFP 144 LQFP		MC68332TS/D MC68332UM/AD MC68331/32EC/D
MC68336	0	4K+3.5K	0	SIM	TPU CTM4	QSM	QADC	—	—	—	5.0	V, M	20, 25	160 QFP		MC68336/376PP/D MC68336/376UM/AD
MC68376	8	4K+3.5K	0	SIM	TPU CTM4	QSM TOUCAN	QADC	—	—	—	5.0	V, M	20, 25	160 QFP		MC68336/376PP/D MC68336/376UM/AD

683xx Reference Manuals

CPU32RM/AD	683xx CPU32 Reference Manual
SIMRM/AD	System Integration Module Reference Manual
TPURM/AD	TPU Reference Manual
GPTRM/AD	General-Purpose Timer Reference Manual
QSMRM/AD	Queued Serial Module Reference Manual
ADCRM/AD	Analog-to-Digital Reference Manual
CTMRM/D	Configurable Timer Reference Manual

Power PC Family

Device	ROM (Kbytes)	RAM (Bytes)	FLASH (Kbytes)	Device Integration	Timer	Serial	MUX	A/D	PWM	Operating Voltage	Temperature	Operating Frequency	Package Options	Comments	Documentation
MPC555	0	26K + 6K for TPUs	448K	USIU	50 channel timer system: 2 TPU2 + MIOS1	QSMCM (2 SCI + QSPI) + 2 TouCAN	—	2 QADC2 (10-bit A/D with 64 result registers on each)	—	3.3 Vdc for core, 5.0 Vdc for FLASH	C, V, M	40MHz	272 PBGA	Power PC core with FPU	MPC555PP/D MPC555UM/W RCPURM/AD
MPC509	0	28 K	0	SIU	16-bit PIT, 32-bit decrementer, 64-bit timebase	—	—	—	—	3.3 Vdc ± 0.3 Vdc	M	25 MHz	144 QFP	4K instruction cache, double precision FPU, IEEE 754 compliant, 12 chip selects, 2 low-power modes	RCPURM/AD SIURM/AD MPC509TS/D MPC509UM/AD

Automotive SMARTMOS (Sheet 1 of 2)

Device	Package	Description	Status	Switches ⁽¹⁾	Interface	$V_{BDSS}/R_{DSON}^{(2)}/I_{Load}$	H Bridge	Driver	Bus Physical Interface	Timer	Comments	Documentation
High-Side Drivers												
MC33091AD/P	8SO/8P	High-side TMOS driver	MC	—	—	—	—	High-side TMOS driver	—	—		MC33091A/D
MC33143DW	24SOWB	Dual high-side switch	MC	Dual high side	Parallel	10V/0.2 Ω /2.0A	—	—	—	—		MC33143/D
MC33198D	8SO	High-side TMOS driver	MC	—	—	—	—	High-side TMOS driver	—	—		Contact sales
MC33285D	8SO	Dual high-side TMOS driver	MC	—	Parallel	—	—	Dual high-side TMOS driver	—	—	PWM capability	Contact sales
MC33286DW/DH	SO20WB/HSOP20	Dual high-side switch (Gemini) (R_{DSON} : 35 m Ω) lamps	XC/PC	Dual high side	Parallel	40V/35m Ω /3A–6A	—	—	—	—	Resistive loads/motor control with diagnostics	Contact sales
MC33288DH	HSOP20	Dual high-side switch (R_{DSON} : 25 m Ω) flasher	MC	Dual high side	Parallel	40V/25m Ω /5A–10A	—	—	—	—	Resistive loads/motor control with diagnostics and current recopy function	Contact sales
MC33289DW	SO20WB	Dual high-side switch (R_{DSON} : 40 m Ω) solenoids	PC	Dual high side	Parallel	40V/40m Ω /3A–6A	—	—	—	—	Inductive loads with diagnostics	Contact sales
MC33486DH	HSOP20	Dual high-side switch for H bridge (R_{DSON} : 15 m Ω) motors	PC	Dual high side	Parallel	40V/15m Ω /10A–20A	H bridge	—	—	—	Motor control with diagnostics and current recopy function	Contact sales
Low-Side Drivers												
MC33287DW	SO20WB	Contact monitoring + dual low-side protected driver	MC	Dual low side	Parallel	65V/1.40 Ω /0.5A	—	—	—	—	Contact monitoring	Contact sales
MC33291DW	24SOWB	Basic octal serial switch (Boss)	MC	8 low-side switches	SPI	65V/1 Ω /0.5A	—	—	—	—	Serial control with diagnostics	MC33291/D
MC33293AT/TV	15-pin SIP	Dual low-side driver (R_{DSON} : 0.25 Ω)	MC	Quad low side	Parallel	80V/0.25 Ω /1.0A	—	—	—	—		MC33293/D
MC33298DW/P	24SOWB/20DIP	Octal serial switch with serial peripheral interface I/O	MC	8 low-side switches	SPI	75V/0.45 Ω /1.0A	—	—	—	—	Serial control with diagnostics	MC33298/D
MC33385DH	HSOP20	Quad low-side driver	MC	Quad low side	Parallel	50V/0.25 Ω /2.0A	—	—	—	—	SPI diagnostics	Contact sales
Multiplexed Transceivers												
MC33199DW	14SO	ISO9141 serial link driver (has K&L lines)	MC	—	—	—	—	—	ISO9141 serial link XSCVR	—	K&L lines (at 200 Kbps)	MC33199/D
MC33290D/P	8SO/8P	ISO9141 serial link interface (K line)	MC	—	—	—	—	—	ISO9141 serial link XSCR	—	K line only — OBD II compatible	MC33290/D
MC33388D	14SO	CAN physical interface	XC	—	—	—	—	—	CAN low-speed tolerant physical interface (125Kbps)	—	CAN differential bus driver	Contact sales

Automotive SMARTMOS (Sheet 2 of 2)

Device	Package	Description	Status	Switches ⁽¹⁾	Interface	$V_{BDSS}/R_{DSON}^{(2)}/I_{Load}$	H Bridge	Driver	Bus Physical Interface	Timer	Comments	Documentation
Multiplexed Transceivers (Continued)												
MC33389DH/DW	HSOP20/SO28WB	SBC-CAN system basis chip	PC	—	SPI	—	—	—	CAN low-speed tolerant physical interface (125Kbps)	—	System basis chip with CAN XSCVR, 2 V-regulators, reset, IRQ	Contact sales
MC33390D	8SO	J1850 serial link transceiver	MC	—	—	—	—	—	J1850 serial link XSCVR	—	GM/Chrysler J1850 Class B	MC33390/D
MC33790	16SOIC	2-channel DSI physical interface for bus masters	XC	—	—	—	—	—	—	—	Physical interface for DSI master nodes	Contact sales
Motor Driver/Controller												
MC33186DH1R2	HSOP20	150-mΩ H-bridge driver	MC	—	—	40V/0.15Ω	H bridge	—	—	—	—	Contact sales
MC33192DW	16SOWB	Stepper motor controller	MC	—	MI bus	—	Stepper motor controller	—	—	—	Mechatronics connector package	MC33192/D
MC33393TM		Stepper motor controller with RAM, ROM, EEPROM, and HC05 core	PC	H-bridge	MI bus	—	Stepper motor controller	—	—	16 bit	Mechatronics connector On-chip oscillator	Contact sales
Alternator/Voltage Regulators												
MC33092ADW	SO20WB	Alternator regulator —GM/9si	MC	—	—	—	—	—	—	—	9si alternator voltage regulator	MC33092/D
MC33099DW	SO20WB	Alternator regulator —GM/9si	PC	—	—	—	—	—	—	—	9si alternator voltage regulator	Contact sales
Automotive Accessory Controls												
MC33187D/P	8SO/8P	Long duration automotive timer	MC	—	—	—	—	—	—	Long duration timer	—	Contact sales
MC33193D/P	8SO/8P	Automotive direction indicator	MC	—	—	—	—	—	—	—	Direction indicator	MC33193/D
MC33197AD/P	8SO/8P	Automotive wash/wiper timer	MC	—	—	—	—	—	—	Wash wiper timer	—	MC33197/D
RF Transmitters/Receivers												
MC33490	16 TSSOP	PLL tuned UHF transmitter (ASK modulation)	MC	—	—	—	—	—	—	—	—	Contact sales
MC33491	14 TSSOP	PLL tuned UHF transmitter (ASK and FSK modulation)	MC	—	—	—	—	—	—	—	—	Contact sales
MC33590	32 LQFP	PLL tuned UHF AM receiver	MC	—	—	—	—	—	—	—	—	Contact sales
MC33690	SO20WB	Standalone TAG reader (with integrated voltage regulator and ISO9141)	MC	—	—	—	—	—	—	—	—	Contact sales

1. Protection of FET switches which may include: short circuit, current limit, over temperature, over voltage, reverse battery, and loss of ground protection

2. R_{DSON} at $T_A = 25\text{ }^\circ\text{C}$ (all)

Sensors/Components

Pressure Sensors

Device	Maximum Pressure Rating	Full Scale Span Voltage (Typical)	Sensitivity (mV/kPa)	Accuracy	Package	Samples	Documentation
MPX4100A	105	4.59	54	± 1.8	6-pin unibody package	Available now	MPX4100A/D
MPXA4100A	105	4.59	54	± 1.8	8-pin, surface mount, small outline package (SOP)	Available now	MPX4100A/D
MPXA4101A	102	4.59	54	± 1.8	8-pin, surface mount, small outline package (SOP)	Available now	MPX4101A/D
MPX4101A	102	4.59	54	± 1.8	6-pin unibody package	Available now	MPX4101A/D
MPX4105A	105	4.59	51	± 1.8	6-pin unibody package	Available now	MPX4105A/D
MPX4115A	115	4.59	45.9	± 1.5	6-pin unibody package	Available now	MPX4115A/D
MPXS4115	115	4.59	45.9	± 1.5	8-pin surface mount package	Available now	MPX4115A/D
MPXA4115	115	4.59	45.9	± 1.5	8-pin, surface mount, small outline package (SOP)	Available now	MPX4115A/D
MPX4200A	200	4.5	25.5	± 1.5	6-pin unibody package	Available now	MPX4200/D
MPX4250A	250	4.6	20	± 1.5	6-pin unibody package	Available now	MPX4250A/D
MPX5010	10	4.5	450	± 5.0	6-pin unibody package	Available now	MPX5010/D
MPXV5010	10	4.5	450	± 5.0	8-pin, small outline package, through-hole or surface mount	Available now	MPX5010/D
MPX5100	100	4.5	4.5	± 2.5	6-pin unibody package	Available now	MPX5100/D
MPX5700	700	4.5	6.4	± 2.5	6-pin unibody package	Available now	MPX5700/D
MPX5999	1000	4.5	4.5	± 2.5	6-pin unibody package	Available now	MPX5999D/D

Distributed Systems Interface Components

Device	Package	Description	Status	Bus Physical Interface	Comments	Documentation
MC68HC55	16 SOIC	2-channel SPI to DSI protocol converter for bus masters	XC	—	Turns any MCU into a DSI master	Contact sales
MC33790	16 SOIC	2-channel DSI physical interface for bus masters	XC	—	Physical interface for DSI master nodes	Contact sales

Automotive Door System

Automotive Door System Example

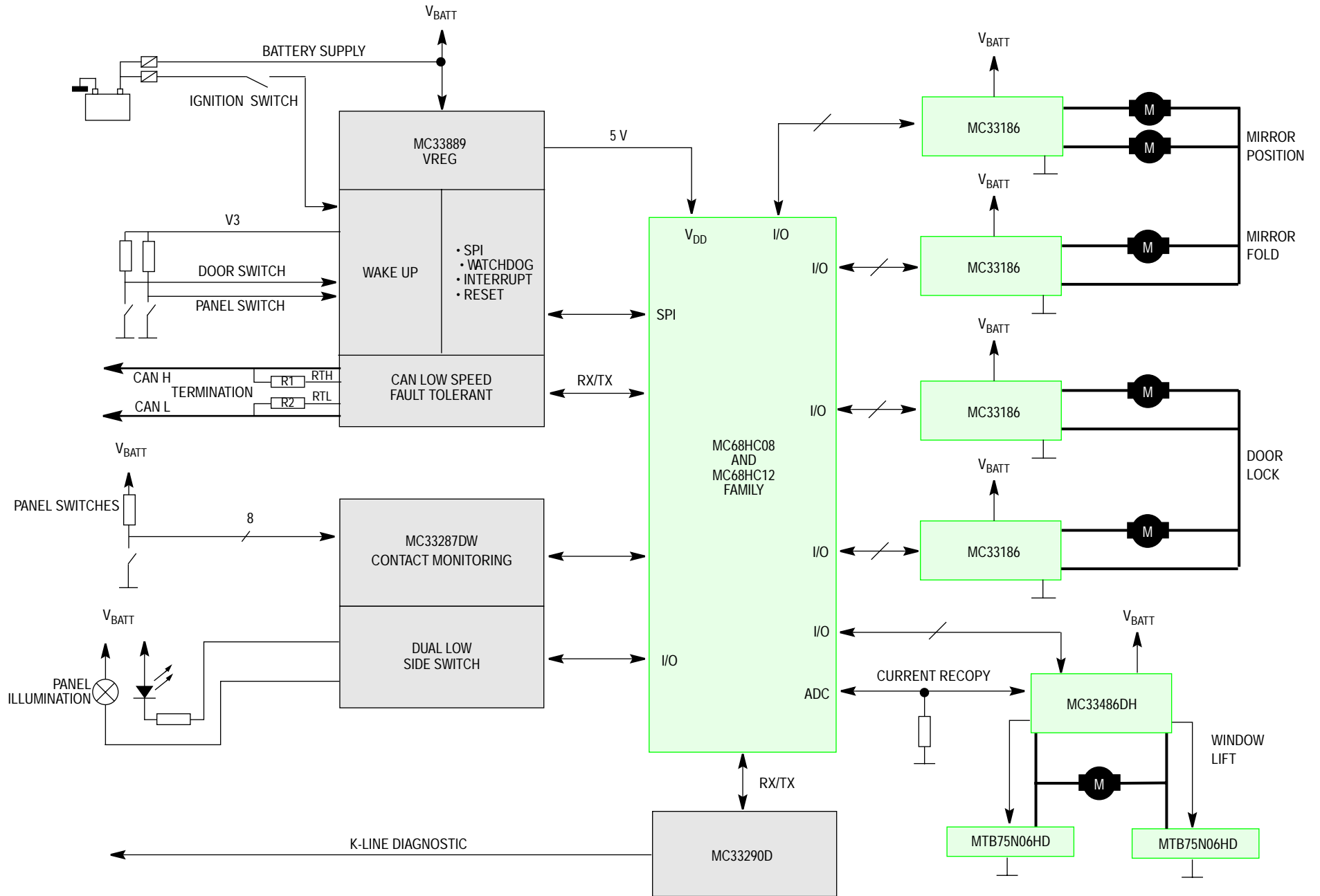

Body Controller Switching Unit Example

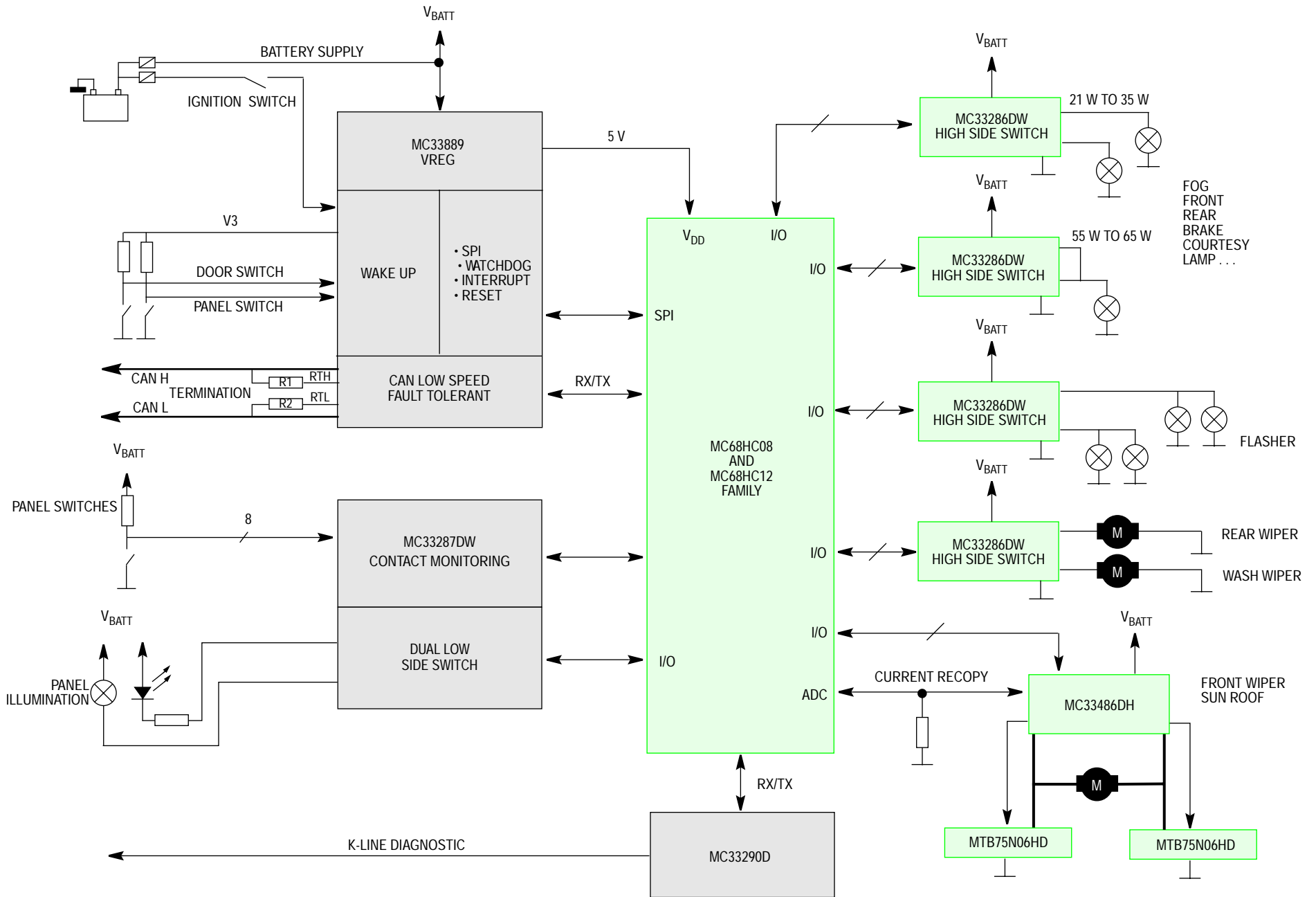

Intelligent Switches Unit

Gasoline Control System Example

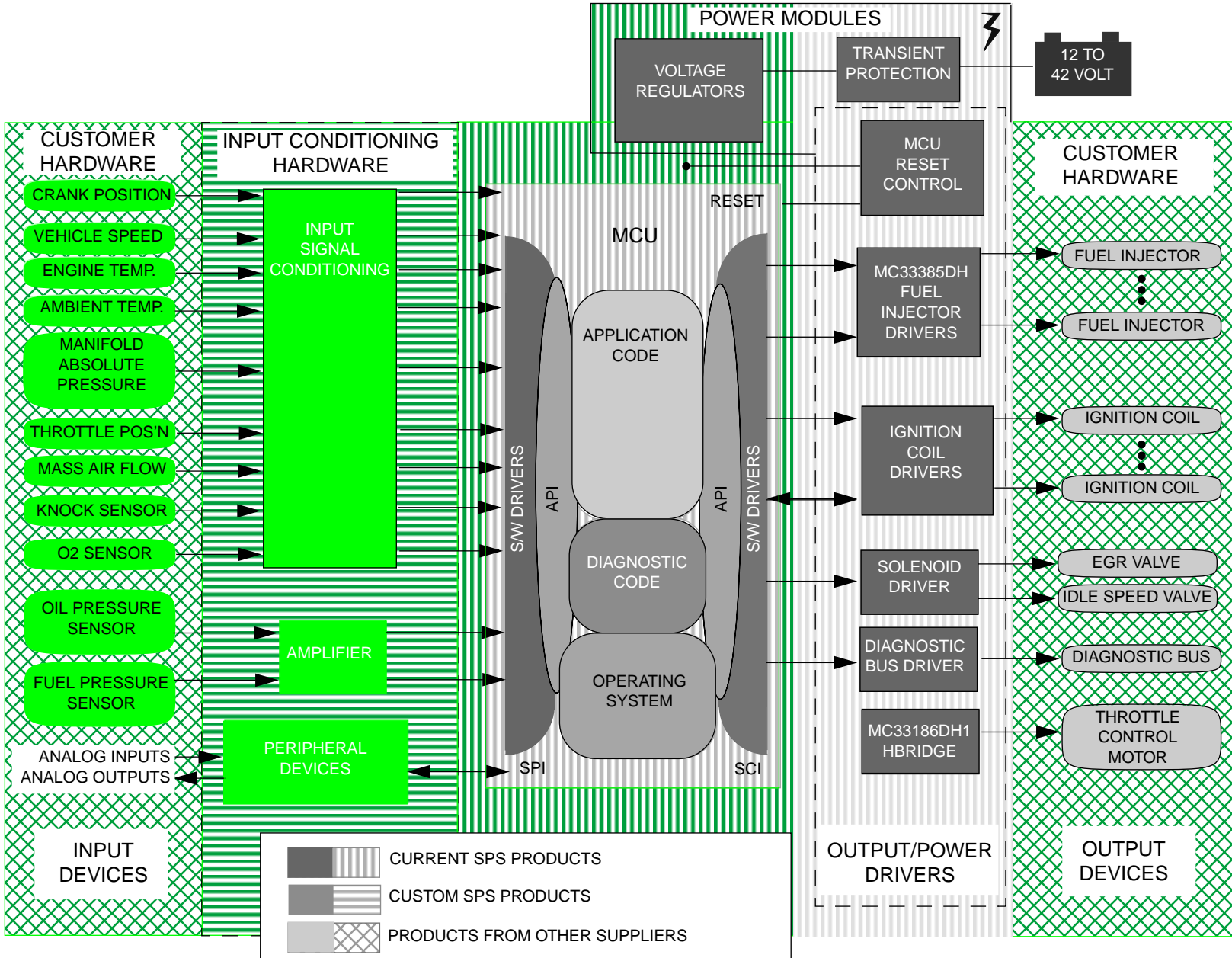

RKE Transmitter/Receiver System Example

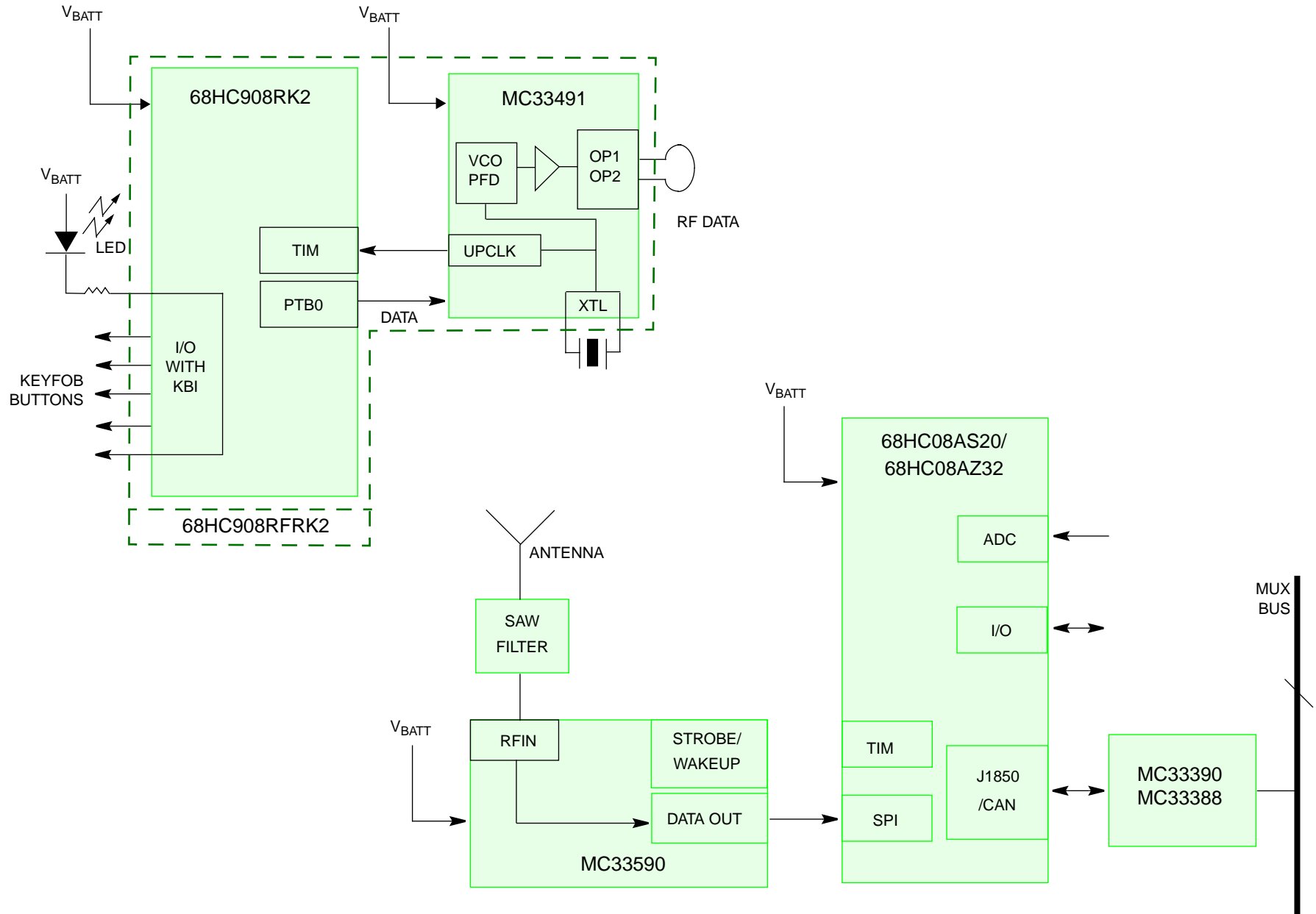

DSI Architecture

DSI Architecture Example

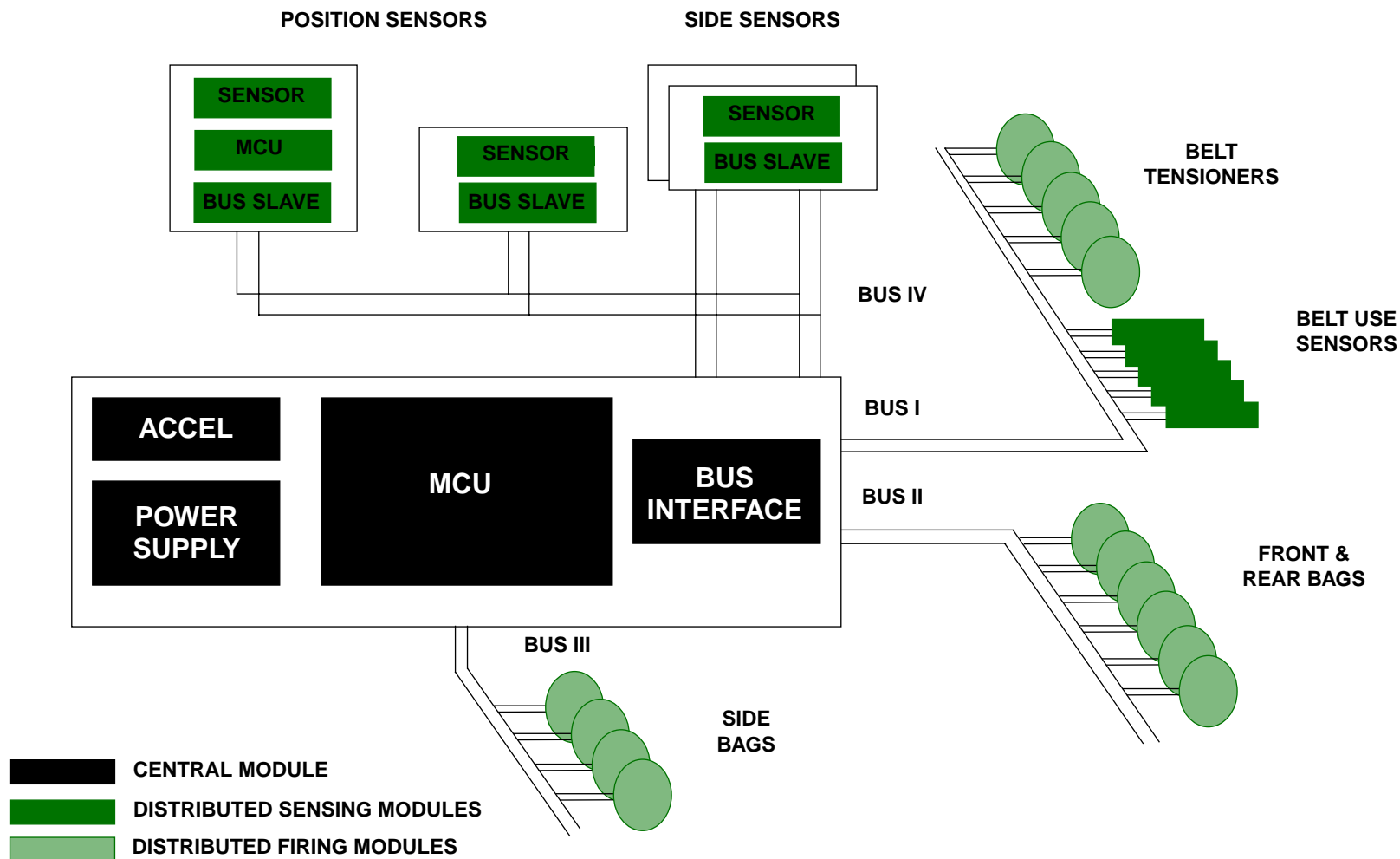

Motorola Single-Point Sensing Solution Example

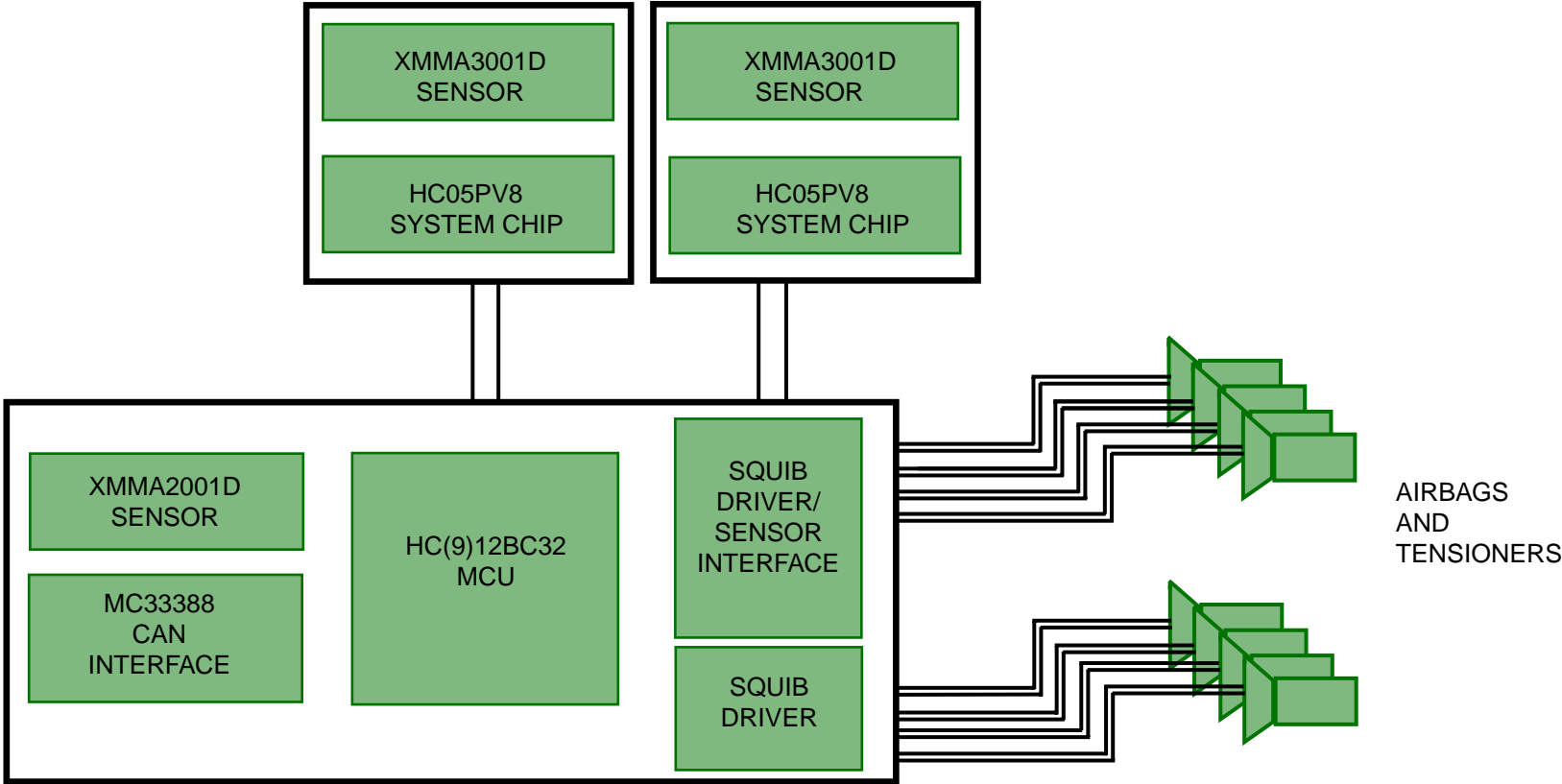

Definitions

— Definitions —

ADC — Analog-to-Digital Converter
BDM — Background Debug Mode
CAN — Controller Area Network
CDIP — Ceramic Dual In-Line Package
CLCC — Ceramic Leaded Chip Carrier
COP — Computer Operating Properly (Watchdog Timer)
CPU16 — 16-Bit Central Processor Unit (HC11 Compatible)
CPU32 — 32-Bit Central Processor Unit (68000 Compatible)
CTM — Configurable Timer Module (Various Hardware Options)
DIP — Dual In-line Package
DTMF — Dual-Tone Multi-Frequency
EBI — External Bus Interface
GPT — General-Purpose Timer Module (4 IC, 5 OC, 2 PWM)
IC — Input Capture
I²C — Inter-Integrated Circuit
i/o — Bidirectional Input and Output Port Pins
i — Input-Only Port Pins
ISPI — Interval Serial Peripheral Interface
KBI — Keyboard Interrupt
LCD — Liquid Crystal Display
LTD — Limited Availability
LQFP — Low-Profile Quad Flat Pack
LVI — Low-Voltage Interrupt
LVR — Low-Voltage Reset
MC — Fully Qualified Production
MCCI — Multi-Channel Communication Interface (2 SCI, SPI)
MFT — Multi Function Timer
MUX — Multiplexed
o — Output-Only Port Pins
OC — Output Compare
PC — Pre-Qualification, Engineering Samples Only
PEEP — Personality EEPROM
PEP — Personality EPROM
PLCC — Plastic Leaded Chip Carrier
PLL — Phase-Locked Loop
PQFP — Plastic Quad Flat Pack
PWM — Pulse-Width Modulation

QADC — Queued Analog-to-Digital Converter (10-Bit)
QFP — Quad Flat Pack
QSM — Queued Serial Module (SCI + QSPI)
QSPI — Queued SPI
RTI — Real-Time Interrupt
SCI — Serial Communication Interface
SCI+ — Enhanced SCI
SCIM — Single-Chip Integration Module
SDIP — Shrink Dual In-line Package
SIM — System Integration Module
SIML — Low-Power System Integration Module
SIOP — Simple Serial I/O Port
SPI — Serial Peripheral Interface
SPI+ — Enhanced SPI
SRAM — Standby RAM Module
TPU — Time Processor Unit (16 Programmable Channels)
TPURAM — Standby RAM Module with TPU Emulation Capability
UART — Universal Asynchronous Receiver/Transmitter
USB — Universal Serial Bus
XC — Initial Production Qualification, Not Fully Characterized

— Package Designators —

B — Shrink DIP (70 mil spacing)
DW — Small Outline (Wide-Body SOIC)
FA — 7 x 7 mm Quad Flat Pack (QFP)
FB — 10 x 10 mm Quad Flat Pack (QFP)
FE — CQFP (windowed) — Samples Only
FN — Plastic Quad (PLCC)
FS — CLCC (windowed) — Samples Only
FT — 28 x 28 mm Quad Flat Pack (QFP)
FU — 14 x 14 mm Quad Flat Pack (QFP)
FZ — CQFP (windowed) — Samples Only
K — Cerdip (windowed) — Samples Only
L — Ceramic Sidebrazed
P — Dual in-Line Plastic
PU — 14 x 14 mm Low-Profile Quad Flat Pack (LQFP)
PV — 20 x 20 mm Low-Profile Quad Flat Pack (LQFP)
S — Cerdip (windowed) — Samples Only
TM — Mechatronics Connector

Device Numbering System for Microcontrollers

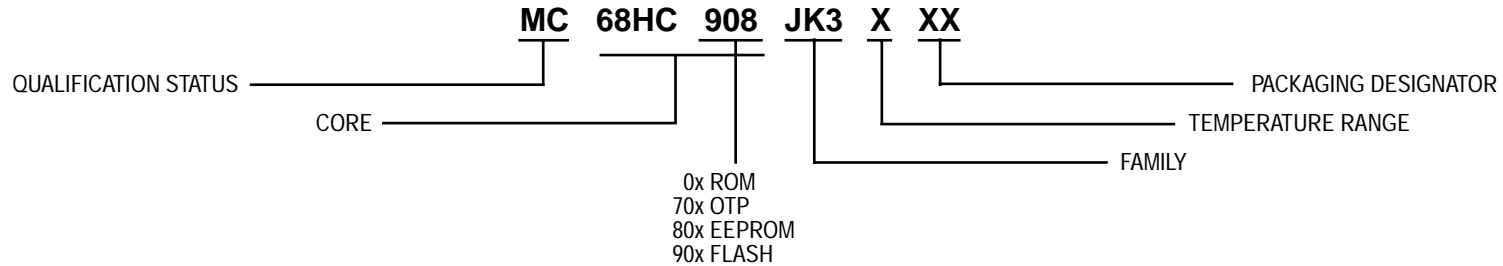

Device Numbering System for Pressure Sensors

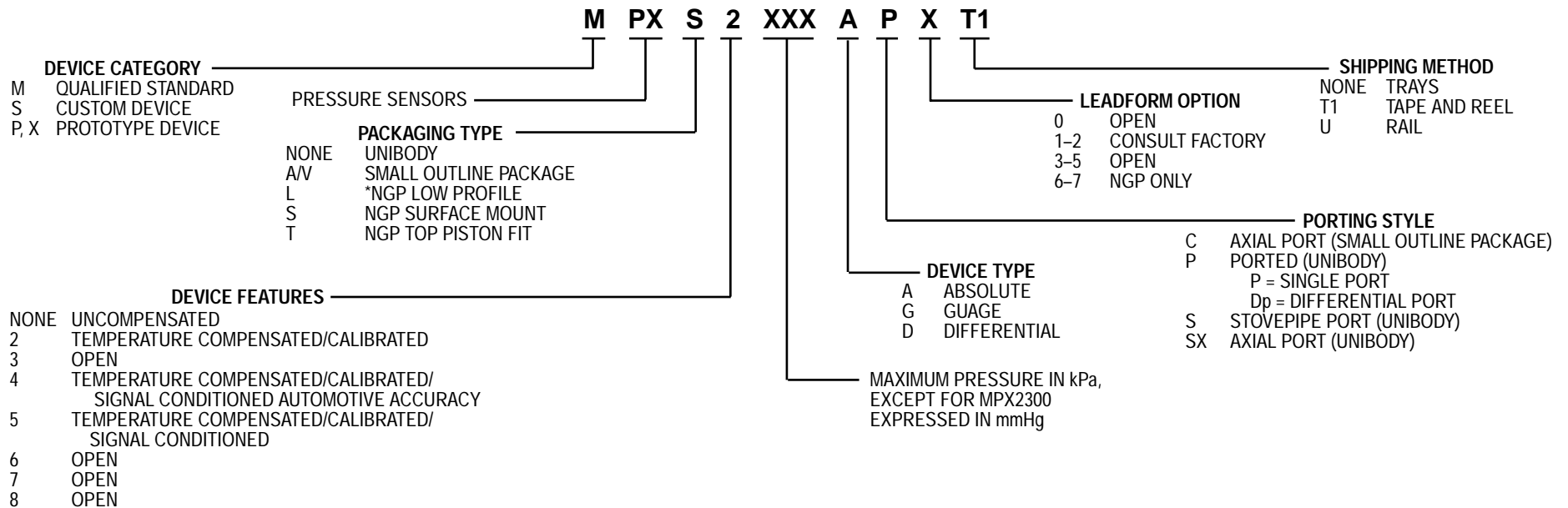

*NGP = NEXT GENERATION PACKING

Package Options (Actual Size)

84-Lead PLCC/CLCC



50 mil/1.27 mm Pitch
1.15 in x 1.15 in Body

68-Lead PLCC/CLCC

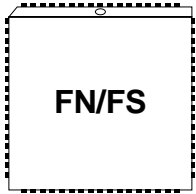

50 mil/1.27 mm Pitch
0.950 in x 0.950 in Body

52-Lead PLCC/CLCC



50 mil/1.27 mm Pitch
0.750 in x 0.750 in Body

44-Lead PLCC/CLCC



50 mil/1.27 mm Pitch
0.650 in x 0.650 in Body

160-Lead QFP

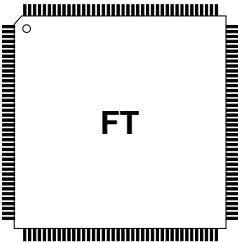

.65 mm Pitch
28 mm x 28 mm Body

144-Lead LQFP

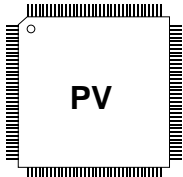

.5 mm Pitch
20 mm x 20 mm Body

132-Lead PQFP

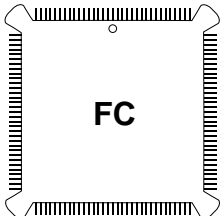

25 mil/06.35 mm Pitch
0.950 in x 0.950 in Body
(Nominal, w.o. Bumpers)

120-Lead QFP/LQFP

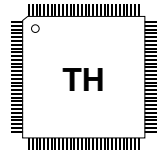

.5 mm Pitch
16 mm x 16 mm Body

112-Lead LQFP

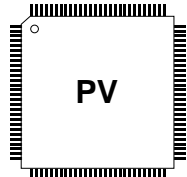

.65 mm Pitch
20 mm x 20 mm Body

100-Lead LQFP

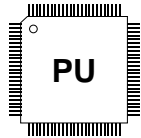

.5 mm Pitch
14 mm x 14 mm Body

80-Lead QFP/LQFP

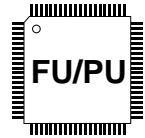

.65 mm Pitch
14 mm x 14 mm Body

64-Lead QFP

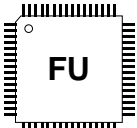

.8 mm Pitch
14 mm x 14 mm Body

52-Lead QFP

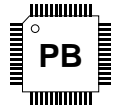

.65 mm Pitch
10 mm x 10 mm Body

44-Lead QFP

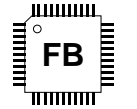

.8 mm Pitch
10 mm x 10 mm Body

32-Lead QFP



.8 mm Pitch
7 mm x 7 mm Body

28-Lead SOIC

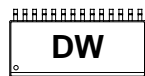

50 mil/1.27 mm Pitch
18.0 mm x 7.5 mm Body

20-Lead SOIC



50 mil/1.27 mm Pitch
12.8 mm x 7.5 mm Body

16-Lead SOIC



50 mil/1.27 mm Pitch
10.35 mm x 7.5 mm Body

48-Pin Plastic DIP

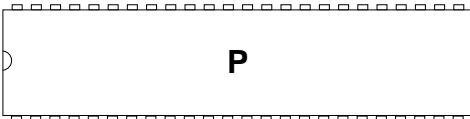

100 mil/2.54 mm Pitch
2.45 in x .55 in Body
(100 mil x 600 mil pin centers)

40-Pin Plastic DIP

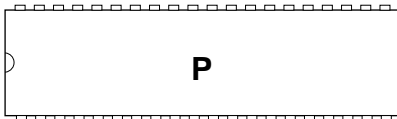

100 mil/2.54 mm Pitch
2.05 in x .55 in Body
(100 mil x 600 mil pin centers)

28-Pin DIP

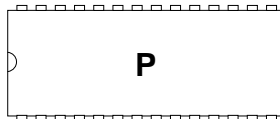

100 mil/2.54 mm Pitch
1.45 in x .55 in Body
(100 mil x 600 mil pin centers)

20-Pin Plastic DIP

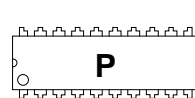

100 mil/2.54 mm Pitch
.97 in x .29 in Body
(100 mil x 600 mil pin centers)

16-Pin Plastic DIP

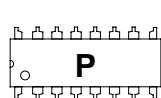

100 mil/2.54 mm Pitch
.75 in x .25 in Body
(100 mil x 600 mil pin centers)

56-Pin Plastic SDIP

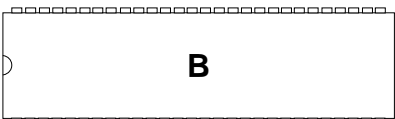

70 mil/1.778 mm Pitch
2.05 in x .55 in Body
(70 mil x 600 mil pin centers)

42-Pin Plastic SDIP

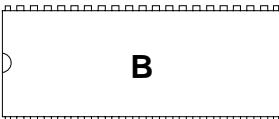

70 mil/1.778 mm Pitch
1.45 in x .55 in Body
(70 mil x 600 mil pin centers)

Package Options (Actual Size)

4-Pin

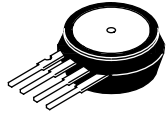

BASIC ELEMENT*
CASE 344-15
SUFFIX A/D

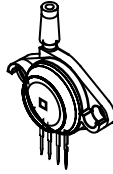

GAUGE PORT*
CASE 344B-01
SUFFIX AP/GP

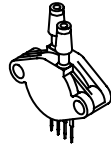

DUAL PORT*
CASE 344C-01
SUFFIX DP

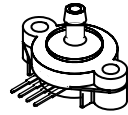

AXIAL PORT
CASE 344F-01
SUFFIX ASX/GSX

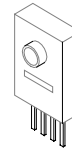

MEDICAL CHIP PAK*
CASE 423A-03

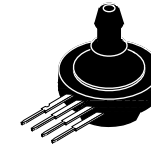

STOVEPIPE PORT
CASE 344E-01
SUFFIX AS/GS

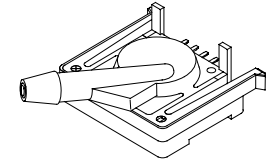

SNAP-FIT
CASE 473B-01
SUFFIX DF

6-Pin

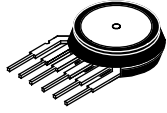

BASIC ELEMENT*
CASE 867-08
SUFFIX A/D



GAUGE PORT*
CASE 867B-04
SUFFIX AP/GP

8-Pin

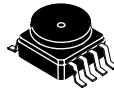

SMALL OUTLINE
(SURFACE MOUNT)*
CASE 482-01

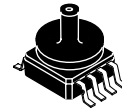

SMALL OUTLINE
(SURFACE MOUNT/PORTED)
CASE 482A-01



SMALL OUTLINE
(DIP)
CASE 482B-03

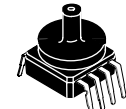

SMALL OUTLINE
(PORTED/DIP)
CASE 482C-03

*Indicates preferred packing options

Motorola reserves the right to make changes without further notice to any products herein. Motorola makes no warranty, representation or guarantee regarding the suitability of its products for any particular purpose, nor does Motorola assume any liability arising out of the application or use of any product or circuit, and specifically disclaims any and all liability, including without limitation consequential or incidental damages. "Typical" parameters which may be provided in Motorola data sheets and/or specifications can and do vary in different applications and actual performance may vary over time. All operating parameters, including "Typicals" must be validated for each customer application by customer's technical experts. Motorola does not convey any license under its patent rights nor the rights of others. Motorola products are not designed, intended, or authorized for use as components in systems intended for surgical implant into the body, or other applications intended to support or sustain life, or for any other application in which the failure of the Motorola product could create a situation where personal injury or death may occur. Should Buyer purchase or use Motorola products for any such unintended or unauthorized application, Buyer shall indemnify and hold Motorola and its officers, employees, subsidiaries, affiliates, and distributors harmless against all claims, costs, damages, and expenses, and reasonable attorney fees arising out of, directly or indirectly, any claim of personal injury or death associated with such unintended or unauthorized use, even if such claim alleges that Motorola was negligent regarding the design or manufacture of the part. Motorola and are registered trademarks of Motorola, Inc. Motorola, Inc. is an Equal Opportunity/Affirmative Action Employer.

How to reach us:

USA/EUROPE/Locations Not Listed: Motorola Literature Distribution, P.O. Box 5405, Denver, Colorado 80217. 1-303-675-2140 or 1-800-441-2447. Customer Focus Center, 1-800-521-6274

JAPAN: Motorola Japan Ltd.; SPS, Technical Information Center, 3-20-1, Minami-Azabu, Minato-ku, Tokyo 106-8573 Japan. 81-3-3440-8573

ASIA/PACIFIC: Motorola Semiconductors H.K. Ltd.; Silicon Harbour Centre, 2 Dai King Street, Tai Po Industrial Estate, Tai Po, N.T., Hong Kong. 852-26668334

Mfax™, Motorola Fax Back System: RMFAX0@email.sps.mot.com; <http://sps.motorola.com/mfax/>; TOUCHTONE, 1-602-244-6609; US and Canada ONLY, 1-800-774-1848

HOME PAGE: <http://motorola.com/sps/>

Mfax is a trademark of Motorola, Inc.

© Motorola, Inc., 2000



MOTOROLA

SG187/D