

MOTOROLA

SG186/D
Rev. 8

Standard Embedded Controller Selector Guide

Quarter 3, 2001

<http://motorola.com/mcu>

Product information for:

8-Bit	68HC05, 68HC08, and 68HC11
16-Bit	68HC12 and 68HC16
32-Bit	68XXX, MCF5XXX, MMC2XXX

 **Digital DNA**TM
from Motorola

MCF5272: NEW 32-Bit Microprocessor

The MCF5272 microprocessor is the most highly-integrated ColdFire® standard device yet to date. In addition to the general-purpose ColdFire peripherals, the MCF5272 features connectivity modules, including a 10/100 Ethernet, a USB 1.1 module, 4 time division multiplex GCI/IDL ports, and an SDRAM controller.

- **Core integration**

- V2 ColdFire core
- 1KB I-cache, 4KB SRAM
- MAC and HW divide modules
- World class debug module

- **Processor integration**

- 10/100 fast Ethernet controller with dedicated DMA
- USB 1.1 device
- 4 TDM GCI/IDL ports
- SDRAM controller
- Widely used general-purpose peripherals: Software HDLC module, QSPI, 2 UARTs, 1 channel DMA, 8 chip selects, general-purpose I/Os, 4 16-bit timers and SW watchdog timer, PWMs, JTAG

- **32-bit non-multiplexed data bus with bus sizing**

- **Enhanced power management:** Doze mode

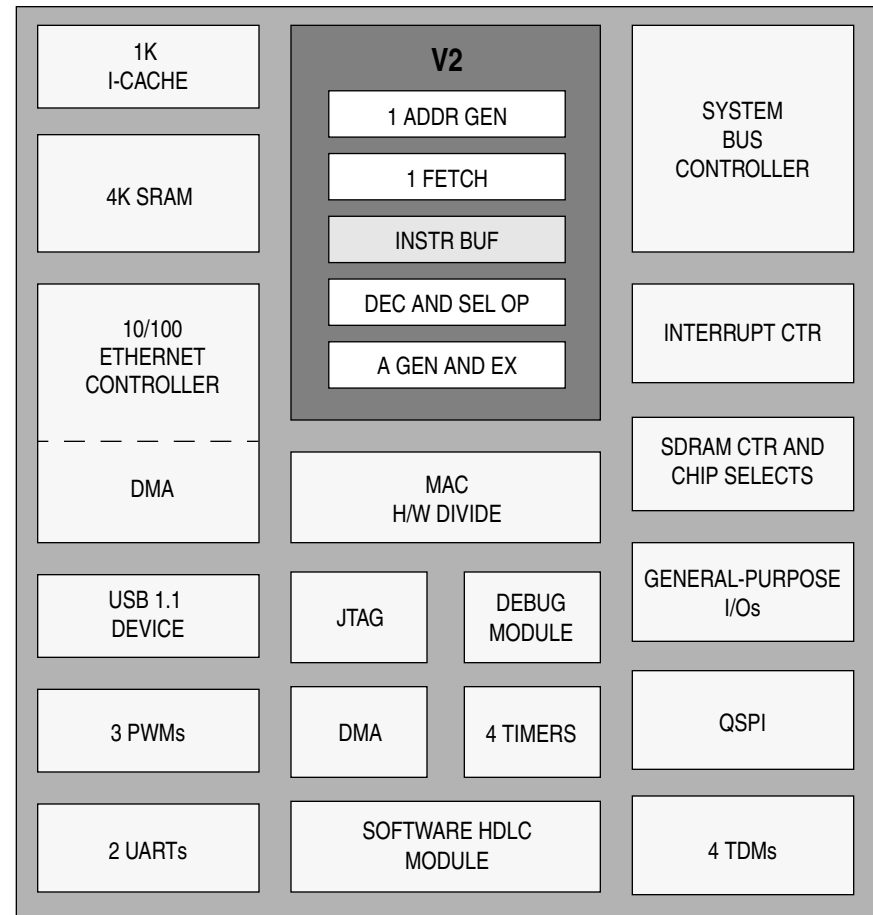

- **High performance:** 63 [Dhrystone 2.1] MIPS @ 66MHz

- **Advanced technology:**

- 196 MAPBGA (15mm by 15mm)
- 3.3V supply / 5V I/O tolerant
- 0.35µm triple layer metal

Device Numbering System for M68HC08

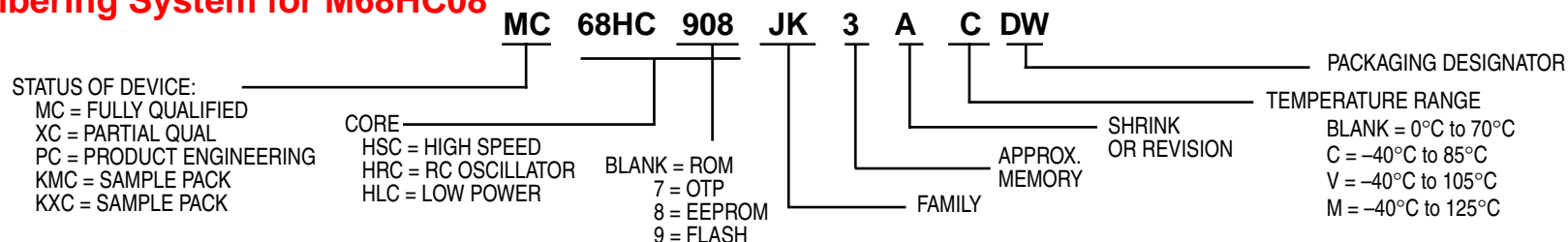

68HC08 Family

Device	ROM (Bytes)	RAM (Bytes)	FLASH or OTP (Bytes)	EEPROM (Bytes)	Timer	I/O	Serial	A/D	PWM	COP	Operating Voltage (V)	Max. Bus Freq. (MHz)	Temp.	Package Options	OTP or FLASH	Avail.	Comments	Documentation
MC68HC08AB16A	16K	512	—	512	4-CH + 4-CH 16-Bit IC, OC, or PWM	51	SCI SPI	8-CH 8-Bit	See Timer	Y	5.0	8.0	C, M	64 QFP (FU)	908AB32	Now	Programmable interrupt timer module	MC68HC08AB16A/D
MC68HC908AB32	—	1K	32K FLASH	512	4-CH + 4-CH 16-Bit IC, OC, or PWM	51	SCI SPI	8-CH 8-Bit	See Timer	Y	5.0	8.0	C, V, M	64 QFP (FU)	—	Now	Programmable interrupt timer module Sample pack part numbers: KMC908AB32CFU/MFU/VFU	MC68HC908AB32/D
MC68HC908AS60	MC908AS60A is a pin-compatible replacement.																	
MC908AS60A	—	2K	60K FLASH	—	6-CH + 2-CH 16-Bit IC, OC, or PWM	48	SCI SPI	15-CH 8-Bit	See Timer	Y	5.0	8.0	C, V, M	64 QFP (FU)	—	Now	J1850; MC908AS60A is pin-for-pin compatible replacement for MC68HC908AS60.	MC68HC908AS60/D
XC68HC08AZ32	32K	1K	—	512	4-CH + 2-CH 16-Bit IC, OC, or PWM	48	SCI SPI	8-CH 8-Bit	See Timer	Y	5.0	8.0	C, V, M	64 QFP (FU)	908AZ60	LTD	CAN 2.0A & 2.0B	HC08AZ32TS/D
MC68HC908AZ60	MC908AZ60A is a pin-compatible replacement.																	
MC908AZ60A	—	2K	60K FLASH	—	6-CH + 2-CH 16-Bit IC, OC, or PWM	48	SCI SPI	15-CH 8-Bit	See Timer	Y	5.0	8.0	C, V, M	64 QFP (FU)	—	Now	MC908AZ60A is pin-for-pin compatible replacement for MC68HC908AZ60.	MC68HC908AZ60/D
MC68HC08BD24	24K	512	—	—	2-CH 16-Bit IC, OC, or PWM	32	I ² C DDC12AB	6-CH, 8-Bit	16-CH, 8-Bit	Y	5.0	3.0	0-70°C only	42 SDIP (B) 44 QFP (FB)	908BD48	Now	For use in digital monitor systems; sync signal processor	MC68HC08BD24/D
MC68HC908BD48	—	1024	48K FLASH	—	2-CH 16-Bit IC, OC, or PWM	32	USB, I ² C DDC12AB	6-CH, 8-Bit	16-CH, 8-Bit	Y	5.0	6.0	0-70°C only	42 SDIP (B) 44 QFP (FB)	—	—	For use in digital monitor systems; sync signal processor	MC68HC908BD48/D
MC68HC08GP32	32K	512	—	—	Dual 2-CH 16-Bit IC, OC, or PWM	33	SCI SPI	8-CH 8-Bit	See Timer	Y	3.0, 5.0	8.0	C, V, M	44 QFP (FB) 42 SDIP (B)	908GP32	Now		MC68HC908GP32/H
MC68HC908GP32	—	512	32K FLASH	—	Dual 2-CH 16-Bit IC, OC, or PWM	33	SCI SPI	8-CH 8-Bit	See Timer	Y	3.0, 5.0	8.0	C	40 DIP (P) 44 QFP (FB) 42 SDIP (B)	—	Now	32-kHz PLL, timebase module, low-voltage inhibit with selectable trip points. Sample pack part numbers: KMC908GP32CFB, KMC908GP32CP, KMC908GP32CB	MC68HC908GP32/H
MC68HC908GR8	—	384	7.5K FLASH	—	2-CH + 1-CH 16-Bit IC, OC, or PWM	21	SCI SPI	4-CH 8 Bit	See Timer	Y	3.0, 5.0	8.0	C	28 SOIC (DW) 28 DIP (P) 32 QFP (FA)	—	Now	28-pin 8K FLASH version of 908GP32, has timebase module	MC68HC908GR8/D
MC68HC08JB1	5.5K	128	—	—	2-CH 16-Bit IC, OC, or PWM	13	USB PS/2	—	See Timer	Y	5.0	3.0	0-70°C only	20 DIP (P) 20 SOIC (JDW)	908JB8	Now	Supports both USB and PS/2; 1.5 Mbps USB with 2 endpoints, low voltage reset, keyboard interrupt, 3.3 V bandgap reference	MC68HC08JB1/D
MC68HC908JB8	—	256	8K FLASH	—	2-CH 16-Bit IC, OC, or PWM	Up to 37	USB	—	See Timer	Y	5.0	3.0	0-70°C only	20 DIP (P) 20 SOIC (JDW) 28 SOIC (DW) 44 QFP (FB)	—	Now	Complies with USB 1.1 spec for low-speed USB (1.5 Mbps) On-chip 3.3 V regulator	MC68HC908JB8/D

68HC08 Family

68HC08 Family

68HC08 Family (Continued)

Device	ROM (Bytes)	RAM (Bytes)	FLASH or OTP (Bytes)	EEPROM (Bytes)	Timer	I/O	Serial	A/D	PWM	COP	Operating Voltage (V)	Max. Bus Freq. (MHz)	Temp.	Package Options	OTP or FLASH	Avail.	Comments	Documentation
MC68HC908JK1	—	128	1.5K FLASH	—	2-CH 16-Bit IC, OC, or PWM	15	—	10-CH 8-Bit	See Timer	Y	3.0, 5.0	8.0	C, M	20 DIP (P) 20 SOIC (DW)	—	Now	RC oscillator option, LVR with selectable trip points, 6-pin LED drive Sample pack part number: see MC68HC908JK3	MC68HC08JL3/H
MC68HC908JK3	—	128	4K FLASH	—	2-CH 16-Bit IC, OC, or PWM	15	—	10-CH 8-Bit	See Timer	Y	3.0, 5.0	8.0	C, M	20 DIP (P) 20 SOIC (DW)	—	Now	RC oscillator option, LVR with selectable trip points, 6-pin LED drive Sample pack part numbers: KMC908JK3CP, KMC908JK3CDW, KMCR908JK3CP, KMCR908JK3CDW	MC68HC08JL3/H
MC68HC08JK3	4K	128	—	—	2-CH 16-Bit IC, OC, or PWM	15	—	10-CH 8-Bit	See Timer	Y	3.0, 5.0	8.0	C, M	20 DIP (P) 20 SOIC (DW)	908JK3	Now	RC oscillator option: 68HRC08JK3, LVR with selectable trip points, 6-pin LED drive	MC68HC08JL3/H
MC68HC908JL3	—	128	4K FLASH	—	2-CH 16-Bit IC, OC, or PWM	23	—	12-CH 8-Bit	See Timer	Y	3.0, 5.0	8.0	C, M	28 DIP (P) 28 SOIC (DW) 48 LQFP (FA)	—	Now	RC oscillator option, LVR with selectable trip points, 6-pin LED drive Sample pack part numbers: KMC908JL3CP, KMC908JL3CDW, KMCR908JL3CP, KMCR908JL3CDW	MC68HC08JL3/H
MC68HC08JL3	4K	128	—	—	2-CH 16-Bit IC, OC, or PWM	23	—	12-CH 8-Bit	See Timer	Y	3.0, 5.0	8.0	C, M	28 DIP (P) 28 SOIC (DW) 48 LQFP (FA)	908JL3	Now	RC oscillator option: 68HRC08JL3, LVR with selectable trip points, 6-pin LED drive	MC68HC08JL3/H
MC68HC08KH12	12K	384	—	—	2-CH, 16-Bit IC, OC, or PWM	42	USB	—	See Timer	Y	3.3 V	6.0	0–70°C only	64 QFP (FU)	708KH12	Now	PC keyboard/hub 12 mbs USB (1 up, 4 down)	MC68HC08KH12/H
MC68HC908KX2	—	192	2K FLASH	—	2-CH 16-Bit IC, OC, or PWM	13	SCI	4-CH 8-Bit	See Timer	Y	3.0, 5.0	8.0	C, V, M	16 DIP (P) 16 SOIC (DW)	—	Now	Internal clock generator (ICG) Sample pack part numbers: KMC908KX2CDW, KMC908KX2CP	MC68HC908KX8/D
MC68HC908KX8	—	192	8K FLASH	—	2-CH 16-Bit IC, OC, or PWM	13	SCI	4-CH 8-Bit	See Timer	Y	3.0, 5.0	8.0	C, V, M	16 DIP (P) 16 SOIC (DW)	—	Now	Internal clock generator (ICG) Sample pack part numbers: KMC908KX8CDW, KMC908KX8CP	MC68HC908KX8/D
MC68HC908LD60	—	1K	60K FLASH	—	2-CH 16-Bit IC, OC, or PWM	39	I ² C, DDC12AB	6-CH, 8-Bit	8-CH 8-Bit	Y	3.3	6.0	C	64 QFP (FU)	—	Now	For use in digital monitor systems.	MC68HC908LD60/D
MC68HC908LD64	—	2K	60K FLASH	—	2-CH 16-Bit IC, OC, or PWM	39	I ² C, DDC12AB, USB w/ hub	6-CH, 8-Bit	8-CH 8-Bit	Y	3.3	6.0	C	64 QFP (FU)	—	Now	For use in digital monitor systems. USB 1.1, composite hub w/ embedded functions. Sync signal processor, on-screen display (OSD) module.	MC68HC908LD64/D
MC68HC908MR16	—	768	16K FLASH	—	4-CH + 2-CH 16-Bit IC, OC, or PWM	44	SCI SPI	10-CH 10-Bit	See Timer + 6-CH 12-Bit	Y	5.0	8.0	C, V	64 QFP (FU) 56 SDIP (B)	—	Now	PWM for 3-phase motor control Sample pack part numbers: KMC908MR16VFU/VB	MC68HC908MR32/D
MC68HC908MR32	—	768	32K FLASH	—	4-CH + 2-CH 16-Bit IC, OC, or PWM	44	SCI SPI	10-CH 10-Bit	See Timer + 6-CH 12-Bit	Y	5.0	8.0	C, V	64 QFP (FU) 56 SDIP (B)	—	Now	PWM for 3-phase motor control Sample pack part numbers: KMC908MR32VFU/VB	MC68HC908MR32/D
MC68HC908RF2	—	128K	2K FLASH	—	2-CH 16-Bit IC, OC, or PWM	14	—	—	See Timer	Y	1.8–3.6	4.0	C	32 QFP (FA)	—	3Q	Integrated RF transmitter in package, internal clock generator (ICG)	MC68HC908RF2/D
MC68HC908RK2	—	128K	2K FLASH	—	2-CH 16-Bit IC, OC, or PWM	14	—	—	See Timer	Y	1.8–3.6	4.0	C	20 SSOP (SD)	—	Now	Internal clock generator (ICG)	MC68HC908RK2/D
MC68HC908SR12	—	512	12K FLASH	—	Dual 2-CH, 16-Bit, IC, OC, or PWM	Up to 31	I ² C, SCI	14-CH, 10-Bit	See Timer + 3-CH, 8-Bit (125 kHz)	Y	3.0, 5.0	8.0	C, M	48 QFP (FA) 42 SDIP (B)	—	Now	RC-oscillator, 32-kHz PLL, internal oscillator options, 8 keyboard interrupts, TBM, temperature sensor, current detect with amplifier, I ² C supports SMBus version 1.0/1.1.	MC68HC908SR12/D

68HC08 Reference Manuals

CPU08RM/AD
TIM08RM/AD

HC08 CPU Reference Manual
HC08 Timer Reference Manual

Device Numbering System for M68HC05

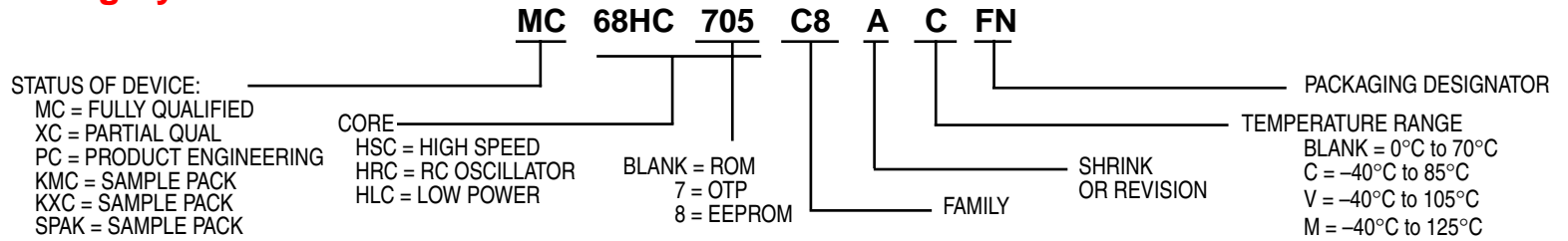

68HC05 Family (Sheet 1 of 3)

Device	ROM (Bytes)	RAM (Bytes)	EPROM/OTP (Bytes)	EEPROM (Bytes)	Timer	I/O	Serial	A/D	PWM	COP	Operating Voltage (V)	Max Bus Frequency (MHz)	Temp.	Package Options	OTP	Avail.	Comments	Documentation
MC68HC05B6	6K	176	—	256	16-Bit 2 IC, 2 OC	32	SCI See comment	8-CH 8-Bit	2-CH 8-Bit	Y	3.3, 5.0	4.0	C, V, M	56 SDIP (B) 52 PLCC (FN) 64 QFP (FU)	705B16 705B32	Now	SCI has synchronous master SPI-like capability	MC68HC05B6/D
MC68HC05B8	7K	176	—	256	16-Bit 2 IC, 2 OC	32	SCI See comment	8-CH 8-Bit	2-CH 8-Bit	Y	3.3, 5.0	4.0	C, V	56 SDIP (B) 52 PLCC (FN) 64 QFP (FU)	705B16 705B32	Now	SCI has synchronous master SPI-like capability	MC68HC05B6/D
MC68HC05B16	15K	352	—	256	16-Bit 2 IC, 2 OC	32	SCI See comment	8-CH 8-Bit	2-CH 8-Bit	Y	3.3, 5.0	4.0	C, V, M	56 SDIP (B) 52 PLCC (FN) 64 QFP (FU)	705B16 705B32	Now	SCI has synchronous master SPI-like capability	MC68HC05B6/D
MC68HC705B16	—	352	15K	256	16-Bit 2 IC, 2 OC	32	SCI See comment	8-CH 8-Bit	2-CH 8-Bit	Y	3.3, 5.0	2.1	C, V, M	52 PLCC (FN) 52 PLCC (FN) 52 CLCC (FS)	—	Now	Use 705B32 as OTP for SDIP. SCI has synchronous master SPI-like capability	MC68HC05B6/D
MC68HC05B32	32K	528	—	256	16-Bit 2 IC, 2 OC	32	SCI See comment	8-CH 8-Bit	2-CH 8-Bit	Y	3.3, 5.0	2.1	PLCC/ QFP: C, V, M SOIC: 0-70°C	56 SDIP (B) 52 PLCC (FN) 64 QFP (FU)	705B32	Now	SCI has synchronous master SPI-like capability	MC68HC05B6/D
XC68HC705B32	—	528	32K	256	16-Bit 2 IC, 2 OC	32	SCI See comment	8-CH 8-Bit	2-CH 8-Bit	Y	3.3, 5.0	2.1	C	56 SDIP (B) 52 PLCC (FN) 64 QFP (FU) 52 CLCC (FS)	—	LTD	SCI has synchronous master SPI-like capability	MC68HC05B6/D
MC68HC05BD5	7.75K	256	—	—	MFT	24	I ² C	—	16-CH 8-Bit	Y	5.0	2.1	0-70°C only	40 DIP (P) 42 SDIP (B)	705BD3	Now	Horizontal & vertical sync signal processor	MC68HC05BD3D/H
MC68HC05C8A	8K	176	—	—	16-Bit 1 IC, 1 OC	31	SCI SPI	—	—	Y	3.3, 5.0	4.0	C, V	40 DIP (P) 42 SDIP (B) 44 PLCC (FN) 44 QFP (FB)	705C8A	Now	KBI (8 pins), 1 high-current pin (20 mA)	HC05C8AGRS/D
MC68HC705C8A	—	304	8K	—	16-Bit 1 IC, 1 OC	31	SCI SPI	—	—	Y	3.3, 5.0	4.0	C, V, M	40 DIP (P) 40 CDIP (S) 42 SDIP (B) 44 PLCC (FN) 44 QFP (FB) 44 CLCC (FS) 64 QFP (FU)	—	Now	KBI (8 pins), 1 high-current pin (20 mA), high-speed option (4-MHz bus) available as MC68HSC705C8A Sample pack part numbers: KMC705C8ACP/S/B KMC705C8ACFB/FN/FS/FU	MC68HC705C8A/D
MC68HC05C9A	16K	352	—	—	16-Bit IC, 1 OC	31	SCI SPI	—	—	Y	3.3, 5.0	4.0	C, V, M	40 DIP (P) 42 SDIP (B) 44 PLCC (FN) 44 QFP (FB)	705C9A	Now	KBI (8 pins), 1 high-current pin (20 mA)	HC05C9AGRS/D
MC68HC705C9A	—	352	16K	—	16-Bit 1 IC, 1 OC	31	SCI SPI	—	—	Y	3.3, 5.0	2.1	C	40 DIP (P) 40 CDIP (S) 42 SDIP (B) 44 PLCC (FN) 44 CLCC (FS) 44 QFP (FB)	—	Now	KBI (8 pins), 1 high-current pin (20 mA) Sample pack part numbers: KMC705C9ACP/S/B KMC705C9ACFN/FS/FB	HC705C9AGRS/D

68HC05 Family

68HC05 Family (Sheet 2 of 3)

Device	ROM (Bytes)	RAM (Bytes)	EPROM/OTP (Bytes)	EEPROM (Bytes)	Timer	I/O	Serial	A/D	PWM	COP	Operating Voltage (V)	Max Bus Frequency (MHz)	Temp.	Package Options	OTP	Avail.	Comments	Documentation
MC68HC705F32	—	920	32K	256	16-Bit 4 IC, 4 OC, MFT, RTI	Up to 80	SCI SPI	8-CH 8-Bit	3-CH 8-Bit	Y	3.0, 5.0	2.1	0-70°C only	100 LQFP (PU) 80 QFP (FU)	—	Now	DTMF, LCD (4 x 40), KBI (8 pins) Note: FU package is XC qualified only	MC68HC05F32/D
MC68HC05J1A	1.2K	64	—	—	MFT, RTI	14	—	—	—	Y	2.0, 3.3, 5.0	4.0	C, V	20 DIP (P) 20 SOIC (DW)	705J1A	Now	KBI (4 pins), mask selectable pulldowns, 4 high-current pins (8 mA)	MC68HC05J1A/D MC68HC05J1AAD/D
MC68HC705J1A	—	64	1.2K	—	MFT, RTI	14	—	—	—	Y	3.3, 5.0	4.0	C, V	20 DIP (P) 20 SOIC (DW)	—	Now	KBI (4 pins), programmable pulldowns, 4 high-current pins (8 mA), RC option avail- able as MC68HRC705J1A, high-speed option available as MC68HSC705J1A	MC68HC705J1A/D
MC68HC05J5A	2.5K	128	—	—	16-Bit 1 IC, MFT, RTI	14	—	—	—	Y	2.2, 5.0	2.1	0-70°C only	20 DIP (P) 20 SOIC (DW) 16 DIP (JP) 16 SOIC (JDW)	705J5A	Now	2 high-current pins (25mA), LVR, RC option available	HC05J5AGRS/H
MC68HC705J5A	—	128	2.5K	—	16-Bit 1 IC, MFT, RTI	14	—	—	—	Y	5.0	2.1	0-70°C only	20 DIP (P) 20 SOIC (DW)	—	Now	2 high-current pins (25mA), LVR, RC option available	HC05J5AGRS/H
MC68HC05JB3	2.5K	144	—	—	16-Bit 1 IC, 1 OC, MFT, RTI	19	USB	—	—	Y	5.0	3.0	0-70°C only	20 DIP (JP) 20 SOIC (JDW) 28 DIP (P) 28 SOIC (DW)	705JB3	Now	1.5 mbs USB with 3 end- points, low-voltage reset, KBI, 3.3 V bandgap refer- ence	HC05JB3GRS/H
XC68HC705JB3	—	144	2.5K	—	16-Bit 1 IC, 1 OC, MFT, RTI	19	USB	—	—	Y	5.0	3.0	0-40°C only	20 DIP (JP) 28 DIP (P) 28 SOIC (DW)	—	Now	1.5 mbs USB with 3 end- points, low-voltage reset, KBI, 3.3 V bandgap refer- ence	HC05JB3GRS/H
MC68HC05JB4	3.5K	176	—	—	16-Bit 1 IC, 1 OC, MFT, RTI	19	USB	6-CH 8-Bit	—	Y	5.0	3.0	0-70°C only	28 DIP (P) 28 SOIC (DW)	705JB4	Now	1.5 mbs USB with 3 end- points, low-voltage reset, KBI, 3.3 V bandgap refer- ence	HC05JB4GRS/H
MC68HC705JB4	—	176	3.5K	—	16-Bit 1 IC, 1 OC, MFT, RTI	19	USB	6-CH 8-Bit	—	Y	5.0	3.0	0-40°C only	28 DIP (P) 28 SOIC (DW) 28 CDIP (S)	—	Now	1.5 mbs USB with 3 end- points, low-voltage reset, KBI, 3.3 V bandgap refer- ence	HC05JB4GRS/H
MC68HC05JJ6	6K	224	—	—	16-Bit 1 IC, 1 OC, MFT, RTI	14	SIOP	4-CH 12-Bit	—	Y	3.3, 5.0	2.1	C	20 DIP (P) 20 SOIC (DW)	705JJ7	Now	2 voltage comparators used as single slope A/D, KBI (8 pins), 6 high-current pins (10 mA), mask selectable pulldowns, LVR	HC05JJ6GRS/D
XC68HC705JJ7	—	224	6K + 64-Bit PEP	—	16-Bit 1 IC, 1 OC, MFT, RTI	14	SIOP	4-CH 12-Bit	—	Y	3.3, 5.0	2.1	C	20 DIP (P) 20 SOIC (DW) 20 CDIP (S)	—	Now	2 voltage comparators used as single slope A/D, KBI (8 pins), 6 high-current pins (10 mA), programmable pull- downs, LVR	HC705JJ7GRS/D
MC68HC05JP6	6K	224	—	—	16-Bit 1 IC, 1 OC, MFT, RTI	22	SIOP	4-CH 12-Bit	—	Y	3.3, 5.0	2.1	C	28 DIP (P) 28 SOIC (DW)	705JP7	Now	2 voltage comparators used as single slope A/D, KBI (8 pins), 6 high-current pins (10 mA), mask selectable pulldowns, LVR	HC05JJ6GRS/D
XC68HC705JP7	—	224	6K + 64-Bit PEP	—	16-Bit 1 IC, 1 OC, MFT, RTI	22	SIOP	4-CH 12-Bit	—	Y	3.3, 5.0	2.1	C	28 DIP (P) 28 SOIC (DW) 28 CDIP (S)	—	Now	2 voltage comparators used as single slope A/D, KBI (8 pins), 6 high-current pins (10 mA), programmable pull- downs, LVR	HC705JJ7GRS/D
MC68HC05K3	0.9K	64	—	16 PEEP	MFT, RTI	10	—	—	—	Y	3.3, 5.0	2.1	C	16 SOIC (DW) 20 SSOP (SD)	805K3	Now	Personality EEPROM, RTI, KBI	MC68HC05K3/D

68HC05 Family (Sheet 3 of 3)

Device	ROM (Bytes)	RAM (Bytes)	EPROM/OTP (Bytes)	EEPROM (Bytes)	Timer	I/O	Serial	A/D	PWM	COP	Operating Voltage (V)	Max Bus Frequency (MHz)	Temp.	Package Options	OTP	Avail.	Comments	Documentation
MC68HC705KJ1	—	64	1.2K	—	MFT, RTI	10	—	—	—	Y	3.3, 5.0	4.0	C	16 DIP (P) 16 SOIC (DW)	—	Now	KBI (4 pins), programmable pulldowns (10 pins), 4 high-current pins (10 mA). RC option available as MC68HRC705KJ1. High-speed standard. 32 kHz low-power version available as MC68HLC705KJ1.	MC68HC705KJ1/D
MC68HC05L16	16K	512	—	—	16-Bit 1 IC, 1 OC, 8-Bit 1 IC, 1 OC, RTI	39	SIOP	—	—	—	2.2, 3.3, 5.0	2.1	C	80 QFP (FU)	705L16	Now	LCD with 4x39 segments, KBI (8 pins), dual oscillators, 8 high-current pins, programmable pullups, open drain	HC05L16GRS/D
MC68HC705L16	—	512	16K	—	16-Bit 1 IC, 1 OC, 8-Bit 1 IC, 1 OC, RTI	39	SIOP	—	—	—	3.3, 5.0	2.1	C	80 QFP (FU)	—	Now	LCD with 4x39 segments, KBI (8 pins), dual oscillators, 8 high-current pins, programmable pullups, open drain	HC05L16GRS/D
MC68HC05L25	6K	176	—	—	16-Bit Event, Timebase	20	SPI	2-CH 8-Bit	—	Y	3.3, 5.0	2.1	C	52 LQFP (PB) 32 LQFP (FA)	705L26	Now	24x4 or 25x3 LCD	HC05L25GRS/D
MC68HC05LJ5	1.2K	64	—	—	MFT, RTI	14	—	—	—	Y	5.0	2.1	0-70°C only	16 DIP (P)	705J5A	Now	RC option available	HC05LJ5GRS/H
MC68HC05P4A	4K	176	—	—	16-Bit 1 IC, 1 OC	21	SIOP	—	—	Y	3.3, 5.0	2.1	C, V	28 DIP (P) 28 SOIC (DW)	705P6A	Now	KBI, 2 high-current pins. Not recommended for electrically noisy environments, EMC sensitive. Halt mode not available.	HC05P4AGRS/D
MC68HC05P6	4.5K	176	—	—	16-Bit 1 IC, 1 OC	21	SIOP	4-CH 8-Bit	—	Y	3.3, 5.0	2.1	C, V, M	28 DIP (P) 28 SOIC (DW) 32 LQFP (FB)	705P6A	Now		MC68HC05P6/D MC68HC05P6AD/D
MC68HC705P6A	—	176	4.5K	—	16-Bit 1 IC, 1 OC	21	SIOP	4-CH 8-Bit	—	Y	3.3, 5.0	2.1	C	28 DIP (P) 28 SOIC (DW) 28 CDIP (S) 28 SSOP (SD)	—	Now	KBI (8 pins), 2 high-current pins (15 mA). Umbrella OTP for P1A, P4A, P6, and P9A	HC705P6AGRS/D
MC68HC05SR3	3.75K	192	—	—	8-Bit	32	—	4-CH 8-Bit	—	—	3.3, 5.0	2.1	C	40 DIP (P) 44 QFP (FB) 42 SDIP (B)	705SR3	Now	LED drive, LVR, KBI	MC68HC05SR3D/H
MC68HC705SR3	—	192	3.75K	—	8-Bit	32	—	4-CH 8-Bit	—	—	3.3, 5.0	2.1	C	40 DIP (P) 40 CDIP (S) 44 QFP (FB) 42 SDIP (B)	—	Now	LED drive, KBI, LVR. OTP for both HC05SU3A & HC05SR3	MC68HC05SR3D/H
MC68HC05SU3A	3.75K	192	—	—	8-Bit	32	—	—	—	—	5.0	2.1	0-70°C only	40 DIP (P)	705SR3	Now	KBI, LED drive	MC68HC05SU3A/H
MC68HC05X4	4K	176	—	—	16-Bit 1 IC, 1 OC, MFT, RTI	16	CAN	—	—	Y	5.0	2.1	C	28 SOIC (DW)	705X4 (limited)	Now	CAN 2.0A (not B)	MC68HC05X4/D
MC68HC05X32	32K	528	—	256	16-Bit 2 IC, 2 OC	32	SCI CAN	8-CH 8-Bit	2-CH 8-Bit	Y	5.0	2.1	C, M	64 QFP (FU)	705X32	Now	4-MHz bus speed available	MC68HC05X16/D
MC68HC705X32	—	528	32K	256	16-Bit 2 IC, 2 OC	32	SCI CAN	8-CH 8-Bit	2-CH 8-Bit	Y	5.0	4.0	C, V, M	64 QFP (FU)	—	Now	CAN 2.0A (not B)	MC68HC05X16/D

68HC05 Reference Manuals

M68HC05AG/AD
M68HC05TB/D

Applications Guide
Understanding Small Microcontrollers Text Book

Device Numbering System for M68HC12

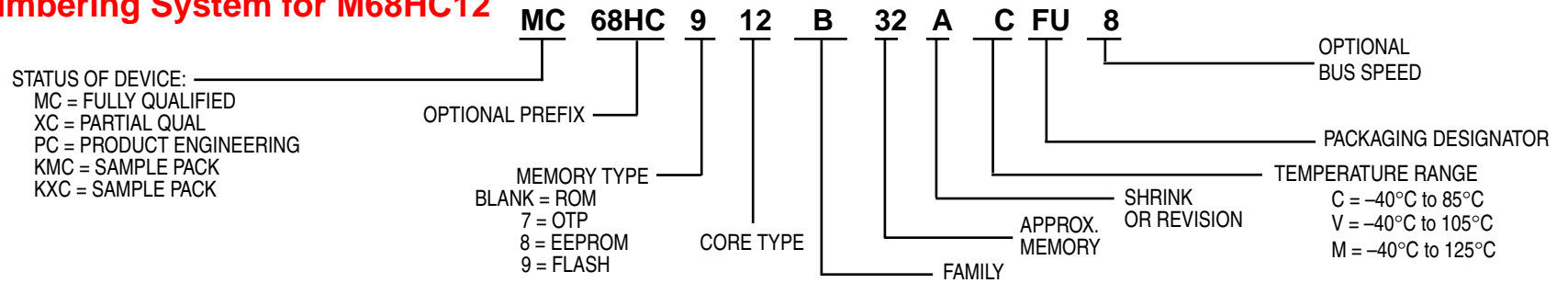

68HC12 Family

Device	ROM (Bytes)	RAM (Bytes)	EEPROM (Bytes)	FLASH (Bytes)	Timer ¹	I/O	Serial	A/D	PWM	Operating Voltage (V)	Max Bus Frequency (MHz)	Temp.	Package Options	Avail.	Comments	Documentation
XC68HC812A4	—	1K	4K	—	8-CH 16-Bit IC or OC RTI, pulse accumulator	Up to 91	Dual SCI SPI	8-CH 8-Bit	—	3.3, 5.0	8.0 5.0	C	112 LQFP (PV) 100 LQFP (PV)	Now	Non-muxed bus, 7 programmable chip selects, KBI (24 pins), PLL, BDM, 5Mbyte external memory, 3.0–3.6V 5MHz version (XC68C812A4) Sample pack part numbers: KXC68C812A4PV5, KXC812A4CPV8	MC68HC812A4/D
MC68HC912B32	—	1K	768	32K	8-CH 16-Bit IC or OC RTI, pulse accumulator	Up to 63	SCI, SPI J1850	8-CH 10-Bit	4-CH 8-Bit or 2-CH 16-Bit	5.0	8.0	C	80 QFP (FU)	Now	J1850, muxed bus, BDM Sample pack part numbers: KMC912B32CFU/VFU/MFU	MC68HC912B/D
XC912BC32	—	1K	768	32K	8-CH 16-Bit IC or OC RTI, pulse accumulator	Up to 63	SCI, SPI CAN	8-CH 10-Bit	4-CH 8-Bit or 2-CH 16-Bit	5.0	8.0	C	80 QFP (FU)	LTD	MSCAN CAN 2.0A and 2.0B, BDM Sample pack part number: KXC912BC32CFU8	MC68HC912B/D
MC68HC12BE32	32K	1K	768	—	8-CH 16-Bit IC or OC RTI, pulse accumulator	Up to 63	SCI, SPI J1850	8-CH 10-Bit	4-CH 8-Bit or 2-CH 16-Bit	5.0	8.0	C	80 QFP (FU)	Now	BDM, enhanced timer Evaluation device with on-chip monitor: XC12BE32DCFU8 Sample pack part number: KXC12BE32DCFU8	MC68HC912B/D
MC68HC912D60	MC912D60A is a pin-compatible replacement.															
XC912D60A	—	2K	1K	60K	8-CH 16-Bit IC or OC RTI, pulse accumulator	Up to 68 i/o and 18 i	Dual SCI SPI, CAN	8-CH or 16-CH 10-Bit	4-CH 8-Bit or 2-CH 16-Bit	5.0	8.0	C, V, M	80 QFP (FU) 112 LQFP (PV)	Now	Replaces the XC68HC912D60 with 5-V FLASH voltage and a different programming algorithm.	MC68HC912D60/D
MC912DG128	MC912DG128A is a pin-compatible replacement.															
MC912DG128A	—	8K	2K	128K	8-CH 16-Bit IC or OC RTI, pulse accumulator	Up to 68 i/o and 18 i	Dual SCI SPI, CAN	8-CH or 16-CH 10-Bit	4-CH 8-Bit or 2-CH 16-Bit	5.0	8.0	C, V, M	112 LQFP (PV)	Now	Replaces the XC912DG128 with 5-V FLASH voltage and a different programming algorithm.	MC68HC912DG128/D

1. All 68HC12 MCUs incorporate a COP watchdog timer.

68HC12 Reference Manual

Device Numbering System for M68HC11

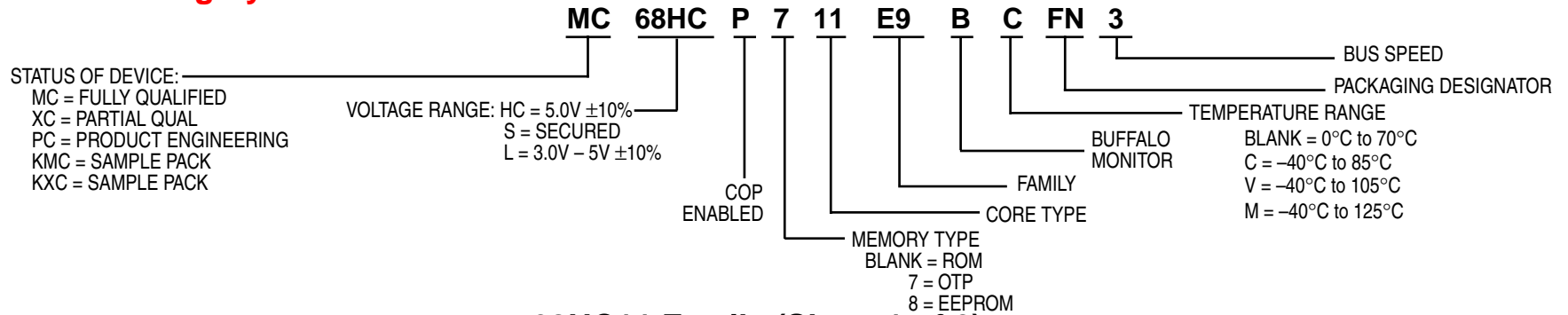

68HC11 Family (Sheet 1 of 2)

Device	ROM (Bytes)	RAM (Bytes)	EPROM/OTP (Bytes)	EEPROM (Bytes)	Timer ¹	I/O S.C.	I/O EXP	Serial	A/D	PWM	Operating Voltage (V)	Max Bus Frequency (MHz)	Temp.	Package Options	OTP	Avail.	Comments	Documentation
MC68HC11D0	—	192	—	—	16-Bit, 3/4IC, 4/5OC, RTI, pulse accumulator	—	16	SCI SPI	—	—	3.0, 5.0	3.0	C, V, M	40 PDIP (P) 44 QFP (FB) 44 PLCC (FN)	711D3	Now	64K external address bus, 3V 2MHz version (MC68L11D0) Sample pack part numbers: KMC11D0CFN3, KMC11D0CP3, KMC11D0CFB3	MC68HC11D3/D
MC68HC11D3	4K	192	—	—	16-Bit, 3/4IC, 4/5OC, RTI, pulse accumulator	32	16	SCI SPI	—	—	3.0, 5.0	3.0	C, V, M	40 PDIP (P) 44 QFP (FB) 44 PLCC (FN)	711D3	Now	64K external address bus, 3V 2MHz version (MC68L11D3)	MC68HC11D3/D
MC68HC711D3	—	192	4K	—	16-Bit, 3/4IC, 4/5OC, RTI, pulse accumulator	32	16	SCI SPI	—	—	5.0	3.0	C, V, M	40 PDIP (P) 44 QFP (FB) 44 PLCC (FN)	—	Now	64K external address bus, 3MHz available in C temperature range only Sample pack part numbers: KMC711D3CFB3, KMC711D3CFN3/MFN3, KMC711D3CP3/MP3	MC68HC711D3/D
MC68HC11E0	—	512	—	—	16-Bit, 3/4IC, 4/5OC, RTI, pulse accumulator	—	22	SCI SPI	8-CH 8-Bit	—	3.0, 5.0	3.0	C, V, M	52 PLCC (FN) 64 QFP (FU) 52 LQFP (PB)	711E9	Now	3V 2MHz version (MC68L11E0) Sample pack part numbers: KMC11E0CFN3/VFN3/MFN3, KMC11E0CFU3, KMC11D0CP3	MC68HC11E/D
MC68HC11E1	—	512	—	512	16-Bit, 3/4IC, 4/5OC, RTI, pulse accumulator	—	22	SCI SPI	8-CH 8-Bit	—	3.0, 5.0	3.0	C, V, M	52 PLCC (FN) 64 QFP (FU) 52 LQFP (PB)	711E9	Now	3V 2MHz version (MC68L11E1) Sample pack part numbers: KMC11E1CFN3/VFN3/MFN3, KMC11E1CFU3, KMC11E1CP3	MC68HC11E/D
MC68HC11E20	20K	768	—	512	16-Bit, 3/4IC, 4/5OC, RTI, pulse accumulator	38	22	SCI SPI	8-CH 8-Bit	—	5.0	3.0	C, V, M	52 PLCC (FN) 64 QFP (FU)	711E20	Now	Enhanced baud rate for 3MHz operation	MC68HC11E/D
MC68HC711E20	—	768	20K	512	16-Bit, 3/4IC, 4/5OC, RTI, pulse accumulator	38	22	SCI SPI	8-CH 8-Bit	—	5.0	4.0	C, V, M	52 PLCC (FN) 64 QFP (FU)	—	Now	Enhanced baud rate for 3MHz operation Sample pack part numbers: KMC711E20MFN3, KMC711E20CFN4, KMC711E20CFU4	MC68HC11E/D

1. All 68HC11 MCUs incorporate a COP watchdog timer.

68HC11 Family

68HC11 Family (Sheet 2 of 2)

Device	ROM (Bytes)	RAM (Bytes)	EPROM/OTP (Bytes)	EEPROM (Bytes)	Timer ¹	I/O S.C.	I/O EXP	Serial	A/D	PWM	Operating Voltage (V)	Max Bus Frequency (MHz)	Temp.	Package Options	OTP	Avail.	Comments	Documentation
MC68HC11E9	12K	512	—	512	16-Bit, 3/4IC, 4/5OC, RTI, pulse accumulator	38	22	SCI SPI	8-CH 8-Bit	—	3.0, 5.0	3.0	C, V, M	52 PLCC (FN) 64 QFP (FU) 52 LQFP (FB) 48 DIP (P)	711E9	Now	3V 2MHz version (MC68L11E9)	MC68HC11E/D
MC68HC711E9	—	512	12K	512	16-Bit, 3/4IC, 4/5OC, RTI, pulse accumulator	38	22	SCI SPI	8-CH 8-Bit	—	5.0	3.0	C, V, M	52 PLCC (FN) 64 QFP (FU)	—	Now	EEPROM block protect Secure version (MC68S711E9) Sample pack part number: KMC711E9CFN4	MC68HC11E/D
MC68HC11F1	—	1K	—	512	16-Bit, 3/4IC, 4/5OC, RTI, pulse accumulator	—	30	SCI SPI	8-CH 8-Bit	—	3.0, 5.0	5.0	C, V, M	68 PLCC (FN) 80 LQFP (PU)	—	Now	64K ext. addr. bus, 4 prog. chip sel, non-mux address/data bus, 3V 3MHz version (MC68L11F1) Sample pack part numbers: KMC11F1CPU4, KMC11F1CPU5, KMC68L11F1CPU3, KMC11F1CFN3/4/5	MC68HC11F1/D
MC68HC11K0	—	768	—	—	16-Bit, 3/4IC, 4/5OC, RTI, pulse accumulator	—	37	SCI+ SPI	8-CH 8-Bit	4-CH 8-Bit or 2-CH 16-Bit	3.0, 5.0	2.0, 3.0, 4.0, 5.0	C, V, M	84 PLCC (FN) 80 QFP (FU)	—	Now	Non-mux bus, extended memory map, 4 chip selects, 3V 3MHz version (MC68L11K0) Sample pack part number: KMC11K0CFN3/4	MC68HC11K4/D
MC68HC11K1	—	768	—	640	16-Bit, 3/4IC, 4/5OC, RTI, pulse accumulator	—	37	SCI+ SPI	8-CH 8-Bit	4-CH 8-Bit or 2-CH 16-Bit	3.0, 5.0	5.0	C, V, M	84 PLCC (FN) 80 QFP (FU)	—	Now	Non-mux bus, extended memory map, 4 chip selects, 3V 3MHz version (MC68L11K1) Sample pack part numbers: KMC68L11K1FU2, KMC11K1CFN3/4	MC68HC11K4/D
MC68HC11K4	24K	768	—	640	16-Bit, 3/4IC, 4/5OC, RTI, pulse accumulator	62	37	SCI+ SPI	8-CH 8-Bit	4-CH 8-Bit or 2-CH 16-Bit	3.0, 5.0	5.0	C, V, M	84 PLCC (FN) 80 QFP (FU)	711K4 (limited)	Now	Non-mux bus, extended memory map, 4 chip selects, 3V 3MHz version (MC68L11K4)	MC68HC11K4/D
MC68HC11KW1	—	768	—	640	16-Bit, 3/4IC, 4/5OC, RTI, pulse accumulator	—	55	SCI+ SPI	10-CH 10-Bit	4-CH 8-Bit or 2-CH 16-Bit	5.0	4.0	C	100 LQFP (PU)	—	Now	4MHz non-mux bus, 2 extra timers, 4 chip selects extended, memory map up to 1Mbyte	MC68HC11KW1/D
MC68HC11P1	—	1K	—	640	16-Bit, 3/4IC, 4/5OC, RTI, pulse accumulator	62	37	Triple SCI SPI	8-CH 8-Bit	4-CH 8-Bit or 2-CH 16-Bit	5.0	4.0	C	84 PLCC (FN)	711P2 (limited)	Now	64K external address bus, MI-bus interface, PLL clock circuitry	MC68HC11P2/D
MC68HC11P2	32K	1K	—	640	16-Bit, 3/4IC, 4/5OC, RTI, pulse accumulator	62	37	Triple SCI SPI	8-CH 8-Bit	4-CH 8-Bit or 2-CH 16-Bit	5.0	4.0	C	84 PLCC (FN)	711P2 (limited)	Now	64K external address bus, MI-bus interface, PLL clock circuitry	MC68HC11P2/D

1. All 68HC11 MCUs incorporate a COP watchdog timer.

68HC11 Reference Manual

Device Numbering System for M68HC16

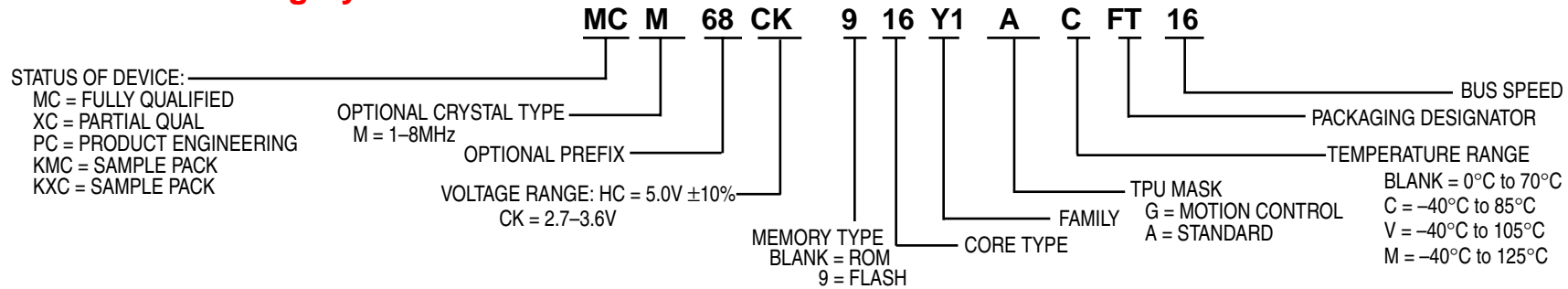

68HC16 Family

Device	ROM (Bytes)	RAM (Bytes)	FLASH (Bytes)	Device Integration	Timer	Serial	Analog	Operating Voltage (V)	Operating Frequency (MHz)	Temp.	Package Options	FLASH	Avail.	Comments	Documentation
MC68HC16R1	48K	2K	—	SCIM2	CTM7	Dual SCI, SPI	8-CH 10-Bit	5.0	16	C, V, M	132 PQFP(FC)	HC916R1	Now		MC68HC16R1PP/D (MC68HC16R1/916R1UM/AD on Web only)
68HC916X1 (XCM916X1)	—	2K	48K+2K	SCIM	GPT	SCI, queued SPI	6-CH 10-Bit	5.0	16	C	120 QFP(TH)	—	Now		MC68HC916X1TS/D
MC68HC16Y1 (MCM16Y1BA)	48K	2K	—	SCIM	GPT, TPU	Dual SCI, SPI	8-CH 10-Bit	5.0	16	C, V, M	160 QFP(FT)	HC916Y1	Now		MC68HC16Y1UM/AD
68HC916Y1 (MCM916Y1)	—	2K+2K	48K+2K	SCIM	GPT, TPU	Dual SCI, SPI	8-CH 10-Bit	5.0	16	C	160 QFP(FT)	—	Now	Sample pack part numbers: KMCM916Y1ACFT16 KMCM916Y1GCFT16	MC68HC16Y1UM/AD
MC68HC916Y3	—	4K	96K+4K	SCIM2	GPT, TPU2	Dual SCI, queued SPI	8-CH 10-Bit	5.0	16	C	160 QFP(FT)	—	Now		MC68HC916Y3PP/D (MC68HC16Y3/916Y3UM/AD on Web only)
MC68HC16Z1	—	1K	—	SIM	GPT	SCI, queued SPI	8-CH 10-Bit	5.0	16, 20, 25	C, V, M	132 PQFP(FC) 144 LQFP(PV)	—	Now	2.7V-3.6V 16MHz version (MC68CK16Z1 in PV package only)	MC68HC16ZUM/AD
MC68HC16Z4	—	1K	—	SIML	GPT	Dual SCI, SPI	8-CH 10-Bit	5.0	16	C	144 LQFP(PV)	—	Now	2.7V-3.6V 16MHz version (MC68CK16Z4) Sample pack part number: KMC16Z4CPV16	MC68HC16ZUM/AD

68HC16 Reference Manuals

CPU16RM/AD	HC16 CPU Reference Manual
SIMRM/AD	System Integration Module Reference Manual
TPURM/AD	TPU Reference Manual
GPTRM/AD	General-Purpose Timer Reference Manual
QSMRM/AD	Queued Serial Module Reference Manual
ADCRM/AD	Analog-to-Digital Reference Manual
CTMRM/D	Configurable Timer Reference Manual
MCCIRM/AD	Multi-Channel Communication Interface Reference Manual
SCIMRM/AD	Single-Chip Integration Module Reference Manual

68HC16 Family

Device Numbering System for MCF5XXX Family

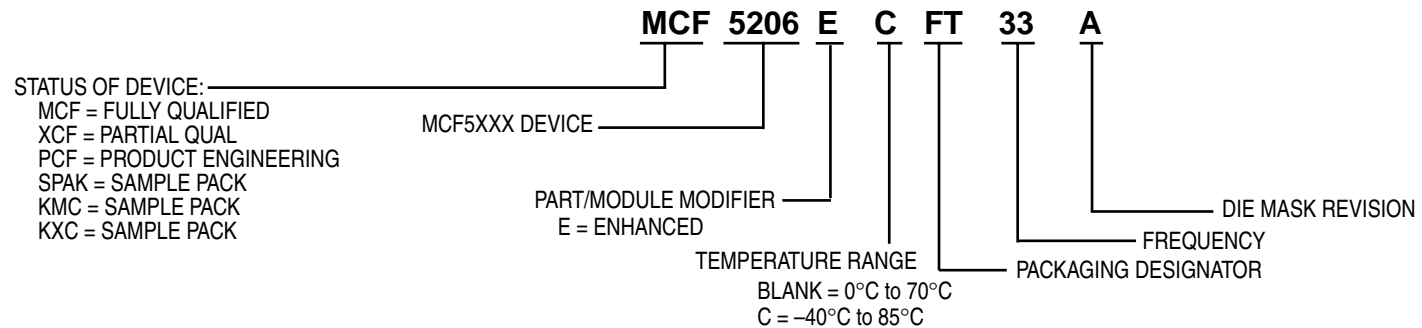

MCF5XXX Family

Device No.	Package	Pkg Description	Speeds (MHz)	Rev	Device Name	Temp (-40 to +85°C)	Sample	Product Description
MCF5102	PV	LQFP 144	20, 25, 33, 40	B	Embedded 68K/ColdFire MPU	N/A	SPAK5102PVXXB	ColdFire microprocessor designed for cost-sensitive embedded control applications. In addition to executing ColdFire code, this first family member is designed with additional capabilities that allow it to execute existing M680x0 code. Processor includes on-chip instruction/data caches (2K/1K, respectively).
MCF5202	PU	TQFP 100	16, 25, 33	B	Embedded 68K/ColdFire MPU	CPU25	SPAK5202PUXXB	ColdFire Version 2 microprocessor designed for cost-sensitive embedded control applications with a 2K unified cache
MCF5204	PU	TQFP 100	16, 25, 33	B	Embedded Integrated 68K/ColdFire MPU	CPU25	SPAK5204PUXXB	ColdFire Version 2 microprocessor designed for cost-sensitive embedded control applications with UART, 2 timers
MCF5206	FT	QFP 160	16, 25, 33	A	Embedded Integrated 68K/ColdFire MPU	CFT16, 25	SPAK5206FTXXA	ColdFire Version 2 microprocessor designed for cost-sensitive embedded control applications with UART, 2 timers, DRAM controller
XCF5206E	FT	QFP 160	40, 54	—	Embedded Integrated 68K/ColdFire MPU	CFT40	SPAK5206EFTXX, SPAK5206ECFT40	ColdFire Version 2 microprocessor with enhanced, pin-compatible version of 5206 with 50 Dhrystone 2.1MIPS @ 54MHz, 4K I-cache, 8K SRAM, MAC, HW divide, I ² C, 2 UARTs, 2 16-bit timers, 2-CH DMA, 3.3V operation, 5.0V tolerant I/O
XCF5272	VF	MAPBGA 196	66	—	Embedded Integrated 68K/ColdFire MPU	N/A	KXCF5272VF66	ColdFire Version 2 microprocessor with: 63 Dhrystone 2.1MIPS @ 66MHz, MAC, HW divide, 1K I-cache, 4K SRAM, 10/100 fast Ethernet controller w/ dedicated DMA, USB 1.1 device module, 4 TDM GCI/IDL ports, software HDLC module, QSPI, SDRAM controller, 2 UARTs, 1-CH DMA, 16-bit GPIOs, 4 16-bit timers, 3 PWMs, world-class BDM, JTAG, 3.3V operation, 5.0V tolerant I/O
MCF5307	FT	FQFP 208	66, 90	B	Embedded Integrated 68K/ColdFire MPU	CFT66	KMCF5307FTXXB KMCF5307CFT66B	ColdFire Version 3 microprocessor with: 75 Dhrystone 2.1MIPS @ 90MHz, 8K unified cache, 4K SRAM, MAC, HW divide, 2 UARTs, 16-bit GPIOs, 4-CH DMA, 2 16-bit timers, PLL, I ² C, 3.3V operation, 5.0V tolerant I/O
PCF5407	FT	FQFP 208	162	—	Embedded Integrated 68K/ColdFire MPU	N/A	PCF5407FT162	ColdFire Version 4 microprocessor: pin-compatible 5307 performance upgrade with: 257 Dhrystone 2.1MIPS @ 162MHz, 16K I-cache, 8K D-cache, 4K SRAM, MAC, HW divide, 1 UART, 1 USART, 16-bit GPIOs, 4-CH DMA, 2 16-bit timers, PLL, I ² C, 1.8V and 3.3V operation, 3.3V tolerant I/O

Device Numbering System for the 68XXX Family

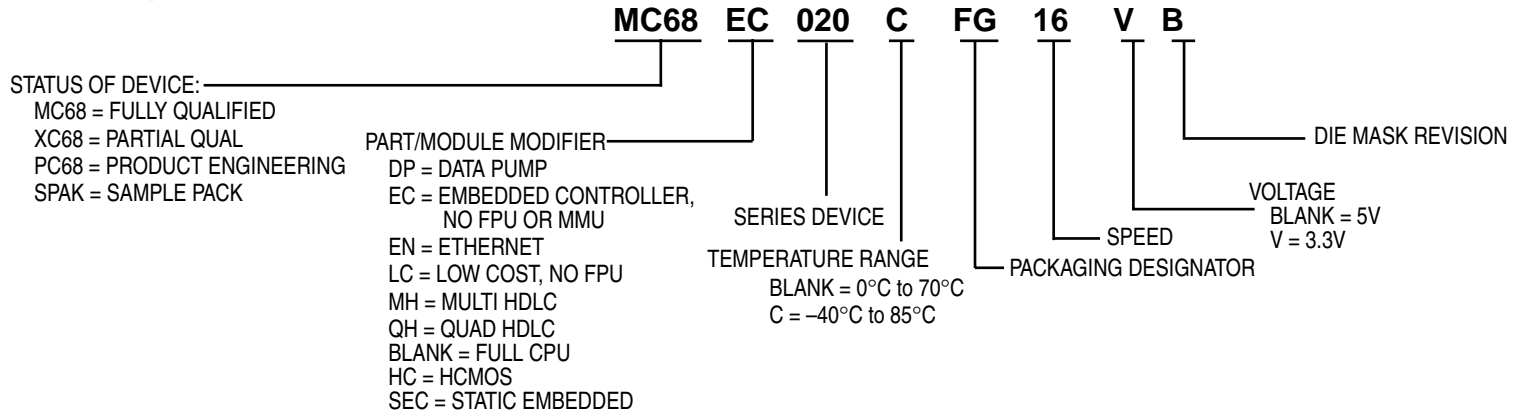

68XXX General-Purpose Processors

Device No.	Package	Device Name	Speeds (MHz)	Rev	Temp** (-40 to +85°C)	SOQ	MPQ	POQ	Brick	Product Description
MC68EC000	68-Lead FN 64-Lead FU 64-Lead PB	8-/16-/32-Bit HCMOS Embedded MPU	8, 10, 12, 16, 20 8, 10, 12, 16, 20 10, 16, 20	—	CFU10, 12, 16, 20 NA	0	18	1008		Low-cost embedded control MPU with 8-/16-bit selectable data bus.
						0	84	420	420	
For FN, FU sample order—SPAKEC000FNXX, SPAKEC000FUXX										
MC68HC000	68-Lead FN, 68-Lead RC	HCMOS 16-/32-Bit MPU	8, 10, 12, 16, 20 8, 10, 12, 16	—	CFN8, 10, 12, 16 CRC8, 10, 12, 16	5	18	1008		Completely pin and timing MC68000-compatibility with a tenth of the power dissipation.
						0	78	780	N/A	
For FC, FN, P, RC sample order—SPAKHC000FCXX, SPAKHC000FNXX, SPAKHC000PXX, SPAKH000RCXX*										
MC68HC001	68-Lead FN, 68-Lead RC	Statically Switchable 8-/16-Bit Data Bus	8, 10, 12, 16	—	CFN8, 10 CRC8	0	18	1008		Functionally compatible with MC68000 and MC68008.
						0	21	210	N/A	
For FN, RC sample order—SPAKHC001FNXX, SPAKHC001RCXX*										
MC68SEC000	64-Lead FU, 68-Lead PB	8-/16-/32-Bit Static HCMOS Embedded MPU	10, 16, 20 10, 16, 20	—	CFU10, 16, 20	0	84	420		Static version of the MC68EC000.
						2	160	800	N/A	
For FU sample order—SPAKSEC000FUXX, SPAKSEC000CFUXX										
MC68020	114-Lead RC 132-Lead FE 132-Lead FC	32-Bit MPU	16, 20, 25, 33 16, 20, 25, 33 16, 20, 25, 33	E E E	CRC16, 20, 25 CFC16, 25	1	1	14		Complete 32-bit MPU. 5-Gbyte linear address space. Co-processor interface. Instruction cache. Dynamic bus sizing. Excellent MPU for graphics control. On-chip cache speeds drawing algorithms. Bit field support for pixel manipulation. (FE packages not recommended for new designs.)
						0	36	180	180	
For FC, FE sample order—SPAK020FCXXE, SPAK020FEXXE, SPAK020RCXXE										
MC68EC020	100-Lead FG	32-Bit Embedded MPU	16, 25	—	CFG16	0	66	264	330	32-bit data bus MPU with 24-bit address bus. Instruction cache. Dynamic bus sizing. Coprocessor interface. Low-cost packaging.
						For FG sample order—SPAKEC020FGXX				
MC68030	128-Lead RC 132-Lead FE	Enhanced 32-Bit MPU	16, 20, 25, 33, 40, 50 16, 20, 25, 33	C C	CRC25, 33	1	14	70	N/A	Complete 32-bit MPU with on-chip instruction and data caches, internal parallel buses, enhanced bus controller, and on-chip MMU.
						0	36	180		
For FE sample order—SPAK030FEXXC, SPAK030RCXXC										

68XXX General-Purpose Processors (Continued)

Device No.	Package	Device Name	Speeds (MHz)	Rev	Temp** (-40 to +85°C)	SOQ	MPQ	POQ	Brick	Product Description
MC68EC030	132-Lead FE	Embedded MPU	25, 40	C C	CFE25	1	36	180	N/A	32-bit MPU for embedded applications. On-chip instruction and data caches provide high-speed access for control routines and data. Utilizes low-cost DRAM bus interface.
						For FE sample order—SPAKEC030FEXXC				
MC68040	179-Lead RC 184-Lead FE	32-Bit MPU MMU FPU	25, 33, 40 25, 33, 40	A A	N/A	1 0	10 24	50 96	N/A	Complete 32-bit MPU with on-chip instruction/data caches (4k bytes each). On-chip MMU. Full IEEE floating point, multiprocessing support with full M68000 Family compatibility.
						For FE sample order—SPAK040FEXX				
MC68EC040	179-Lead RC 184-Lead FE	Embedded 32-Bit High Performance Processor	20, 25, 33, 40 20, 25, 33, 40	A A	BRC33 N/A	1 0	10 24	50 96	100	High-performance 32-bit MPU with on-chip instruction and data cache provides high-speed access for control routines and data. Utilizes low-cost DRAM bus interface.
						For FE sample order—SPAKEC040FEXX				
MC68LC040	179-Lead RC 184-Lead FE	High Performance 32-Bit Processor	20, 25, 33, 40 20, 25, 33, 40	A A	BRC33 N/A	1 0	10 24	50 96	N/A	68040-compatible integer unit and MMU. Ideal solution for cost-sensitive computer or sophisticated embedded applications.
						For FE sample order—SPAKLC040FEXX				
MC68040V	179-Lead RC 184-Lead FE	32-Bit MPU MMU, Low-Voltage	25, 33, 40 @ 3.3 V 25, 33, 40 @ 3.3 V	—	N/A	1 0	10 24	50 96	N/A	Low-voltage complete 32-bit MPU with on-chip instruction/data caches (4k bytes each). On-chip MMU. Multiprocessing support.
						For FE sample order—SPAKEC040VFEXX				
MC68060	206-Lead RC	Superscalar 32-Bit Processor	50, 60	—	N/A	0	10	50	N/A	RISC hybrid superscalar MPU with full M68000 Family compatibility. Includes dual integer units, on-chip instruction/data caches (8K bytes each), on-chip MMU, and full IEEE compliant FPU.
						For RC sample order—SPAK060RCXX				
MC68EC060	206-Lead RC 304-Lead ZU	Superscalar 32-Bit Processor	50, 66, 75 50, 66, 75	—	N/A	0 1	10 27	50 135	N/A	RISC hybrid superscalar MPU with full M68000 Family compatibility. Includes dual integer units, on-chip instruction/data caches (8K bytes each). Ideal for high-performance embedded control applications.
						For sample order—SPAKEC060ZUXXE, SPAKEC060RCXXE				
MC68LC060	206-Lead RC 304-Lead ZU	Superscalar 32-Bit Processor	50, 66, 75 50, 66, 75	—	N/A	0 0	10 27	50 135	N/A	RISC hybrid superscalar MPU with full M68000 Family compatibility. Includes dual integer units, on-chip instruction/data caches (8K bytes each) and on-chip MMU.
						For RC sample order—SPAKLC060RCXX				
MC68882	68-Lead RC 68-Lead FN	Enhanced Floating- Point Coprocessor (EFPCP)	16, 20, 25, 33, 40, 50 16, 20, 25, 33, 40	A A	CRC16, 20, 25, 33 CFN16, 20, 25, 33	1 1	21 18	84 18	N/A	Pin-to-pin timing and software compatibility with MC68881. Dual ported registers and increased pipelining allows 2-4 × performance of MC68881. (Not recommended for new designs.)
						For sample order—SPAK68882RCXXA, SPAK68882CRCXXA, SPAK68882CFNXXA, SPAK68882FNXXA				
MC68306	132-Lead FC 144-Lead PV	Integrated EC000 Processor	16 16, 20	B B	CFC16	0 0	36 60	144 300	300	68000 CPU, 68681 DUART, DRAM control all in one chip.
						For FC, PV sample—SPAK306FCXXB, SPAK306PVXXB, SPAK306CFC16B				
MC68340	144-Lead FE 144-Lead PV 144-Lead FT 144-Lead PV 144-Lead FE	Integrated Processor with DMA	16, 25 @ 5 V 16, 25 @ 5 V 16, 25 @ 5 V 16 @ 3.3 V 16 @ 3.3 V	E E E E E	CFE16, CFE25 CPV16, CPV25 CFT16, CFT25	0 0 0	24 60 24	120 300 120	120 300 120	CPU32 core processor for data movement applications. Two channel DMA, two serial channels, two timers, chip selects, wait-state generation, and glue logic. (FE package not recommended for new designs.)
						For PV sample order—SPAK340PV16E, SPAK340PV16VE, SPAK340PV25E				
						For FE sample order—SPAK340FE16E, SPAK340FE25E				
						For FT sample order—SPAK340FT16E, SPAK340FT25E				

NOTE: **Extended temperature devices with minimum order requirements. All package/speed combinations may not be valid — consult factory to verify.

Device Numbering System for 683XX Family

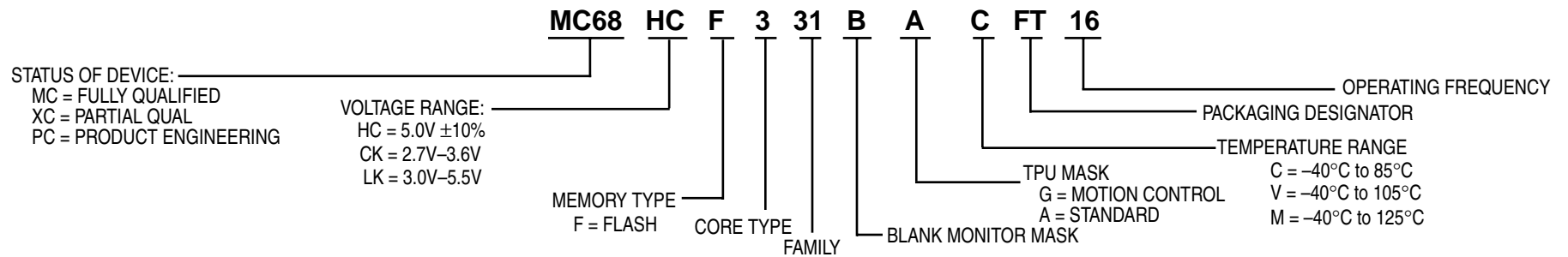

683XX Family

Device	ROM (Bytes)	RAM (Bytes)	FLASH (Bytes)	Device Integration	Timer	Serial	A/D	Operating Voltage (V)	Operating Frequency (MHz)	Temp.	Package Options	Avail.	Comments	Documentation
MC68331	—	—	—	SIM	GPT	SCI, queued SPI	—	5.0	16, 20, 25	C, V, M	132 PQFP 144 LQFP	Now	2.7V–3.6V 16MHz version (MC68CK331) Sample pack part numbers: KMC68331CPV25, KMC68331CFC20, KMC68331CFC2	MC68331UM/AD MC68CK331EC16/D
MC68332	—	2K	—	SIM	TPU	SCI, queued SPI	—	5.0	16, 20, 25	C, V, M	132 PQFP 144 LQFP	Now	3.0V–3.6V 16MHz version (MC68LK332) Sample pack part numbers: KMC68332ACFC20, KMC68332AMPV20	MC68332UM/AD MC68LK332EC16/D
MC68336	—	4K+3.5K	—	SIM	TPU CTM4	SCI, queued SPI	Queued 16-CH 10-Bit	5.0	20, 25	V, M	160 QFP	Now		MC68336/376PP/D MC68336/376UM/AD
MC68376	8K	4K+3.5K	—	SIM	TPU CTM4	TOUCAN, SCI, queued SPI	Queued 16-CH 10-Bit	5.0	20, 25	V, M	160 QFP	Now		MC68336/376PP/D MC68336/376UM/AD

683xx Reference Manuals

CPU32RM/AD
 SIMRM/AD
 TPURM/AD
 GPTRM/AD

683xx CPU32 Reference Manual
 System Integration Module Reference Manual
 TPU Reference Manual
 General-Purpose Timer Reference Manual

QSMRM/AD
 ADCRM/AD
 CTMRM/D

Queued Serial Module Reference Manual
 Analog-to-Digital Reference Manual
 Configurable Timer Reference Manual

MMC2XXX Family

Device Numbering System for M•CORE

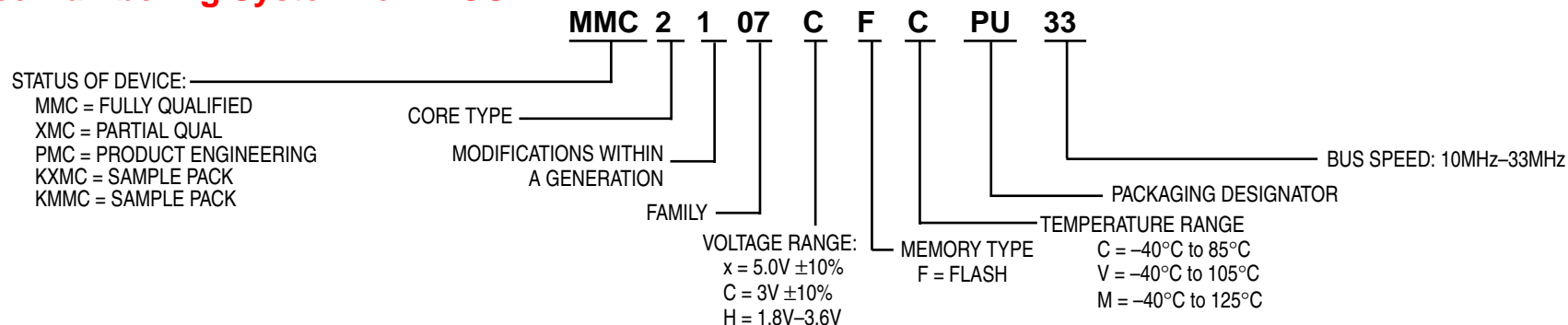

MMC2XXX Family

Device	ROM (Bytes)	RAM (Bytes)	FLASH (Bytes)	Timer	PWM	Serial	A/D	Operating Voltage (V)	Operating Frequency (MHz)	Temp.	Package Options	Avail.	Comments	Documentation
M•CORE MMC2001	256K	32K	—	Time-of-day, periodic interrupt timer, COP	6-CH 10-Bit	Dual UART Interval SPI	—	1.8–3.6	33	C	144 LQFP	Samples Now	ROM includes debugger, peripheral device drivers, and a monitor; external bus interface with 22 address/16 data and 4 chip selects, OnCE debug module, KBI (16 pins) Sample part number: KMMC2001HCPV33B	MMC2001RM/D M•CORERM/AD
M•CORE MMC2107	—	8K	128K	4-channel dual 16-bit capture/compare, PWM capability watchdog	See Timer	Dual SCI, SPI	Queued 8-CH 10-Bit	2.7–3.6	33	C	100 LQFP 144 LQFP	Now	PLL clock, 32 source interrupt controller, interrupt timer, external bus interface with 22 address/16 data and 4 chip selects, OnCE debug module Sample part numbers: KMMC2107CFCPU33 (100 LQFP), KMMC2107CFCPV33 (144 LQFP)	MMC2107/D M•CORERM/AD

— Definitions —

ADC — Analog-to-Digital Converter
BDM — Background Debug Mode
Brick — 5 Full Trays and 1 Cover Tray
C — -40°C to +85°C Operating Temperature Range
CAN — Controller Area Network
COP — Computer Operating Properly (Watchdog Timer)
CTM — Configurable Timer Module (Various Hardware Options)
DTMF — Dual-Tone Multi-Frequency
EBI — External Bus Interface
FPU — Floating Point Unit
GPT — General-Purpose Timer Module (4 IC, 5 OC, 2 PWM)
IC — Input Capture
I²C — Inter-Integrated Circuit
i/o — Bidirectional Input and Output Port Pins
i — Input-Only Port Pins
ICG — Internal Clock Generator
ISPI — Interval Serial Peripheral Interface
KBI — Keyboard Interrupt
LCD — Liquid Crystal Display
LED — Light-Emitting Diode
LTD — Limited Availability
LVI — Low-Voltage Inhibit
LVR — Low-Voltage Reset
M — -40°C to +125°C Operating Temperature Range
MC — Fully Qualified Production
MCCI — Multi-Channel Communication Interface (2 SCI, SPI)
MCU — Microcontroller Unit
MFT — Multi-Function Timer
MMU — Memory Management Unit
MPQ — Minimum Purchase Quantity
MPU — Microprocessor Unit
MUX — Multiplexed
o — Output-Only Port Pins
OC — Output Compare
PC — Pre-Qualification, Engineering Samples Only
PEEP — Personality EEPROM
PEP — Personality EPROM
PLL — Phase-Locked Loop
POQ — Purchase Order Quantity (Box)
PWM — Pulse-Width Modulation
QADC — Queued Analog-to-Digital Converter (10-Bit)
QSM — Queued Serial Module (SCI + QSPI)
QSPI — Queued SPI

RTI — Real-Time Interrupt
SCI — Serial Communication Interface
SCI+ — Enhanced SCI
SCIM — Single-Chip Integration Module
SIM — System Integration Module
SIML — Low-Power System Integration Module
SIOP — Simple Serial I/O Port
SOQ — Sample Order Quantity
SPI — Serial Peripheral Interface
SPI+ — Enhanced SPI
SRAM — Standby RAM Module
TBM — Timebase Module
TPU — Time Processor Unit (16 Programmable Channels)
TPURAM — Standby RAM Module with TPU Emulation Capability
UART — Universal Asynchronous Receiver/Transmitter
USB — Universal Serial Bus
V — -40°C to +105°C Operating Temperature Range
XC — Initial Production Qualification, Not Fully Characterized

— Package Acronyms —

CDIP — Ceramic Dual In-Line Package
CLCC — Ceramic Leaded Chip Carrier
CQFP — Ceramic Quad Flat Pack
DIP — Dual In-line Package
LQFP — Low-Profile Quad Flat Pack
MAPBGA — Mold Array Process Ball Grid Array
PBGA — Plastic Ball Grid Array
PLCC — Plastic Leaded Chip Carrier
QFP — Quad Flat Pack
QFP — Quad Flat Pack
SDIP — Shrink Dual In-line Package
SOIC — Small Outline Integrated Package
SSOP — Shrink Small Outline Package

Package Options (Actual Size) Sheet 1 of 2

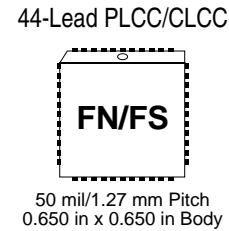
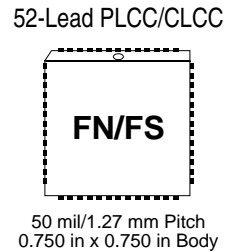
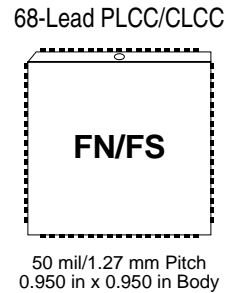
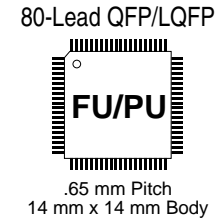
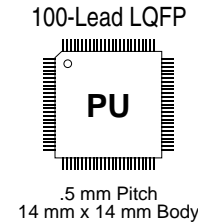
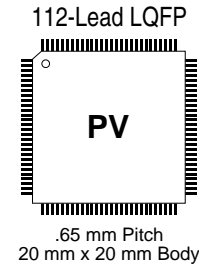
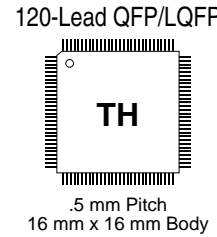
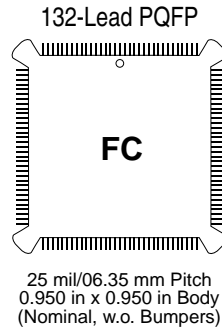
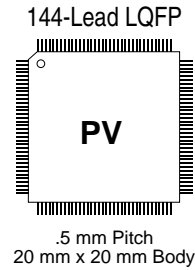
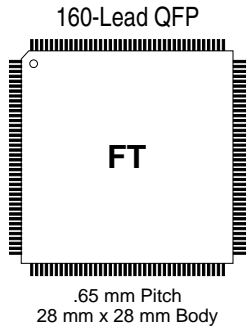

— Package Designators —

- B — Shrink DIP (70 mil spacing)
- DW — Small Outline (Wide-Body SOIC)
- FA — 7 x 7 mm Quad Flat Pack (QFP)
- FB — 10 x 10 mm Quad Flat Pack (QFP)
- FC — Plastic Quad (Gull Wing)
- FE — CQFP (windowed) — Samples Only
- FG — 14 x 20 mm Plastic Quad Flat Pack (PQFP)
- FN — Plastic Quad (PLCC)
- FS — CLCC (windowed) — Samples Only
- FT — 28 x 28 mm Quad Flat Pack (QFP)
- FU — 14 x 14 mm Quad Flat Pack (QFP)
- FZ — CQFP (windowed) — Samples Only
- K — Cerdip (windowed) — Samples Only
- L — Ceramic Sidebrazed
- P — Dual in-Line Plastic
- PB — 10 x 10 mm Quad Flat Pack (QFP)
- PU — 14 x 14 mm Low-Profile Quad Flat Pack (LQFP)
- PV — 20 x 20 mm Low-Profile Quad Flat Pack (LQFP)
- RC — Pin Grid Array, Gold Lead Finish
- S — Cerdip (windowed) — Samples Only
- SD — Shrink Small Outline Package (SSOP)
- VF — 1.6 mm Thick MAPBGA
- ZP — Plastic Ball Grid Array (PBGA)
- ZU — Tape Ball Grid Array, 352 and 480 Lead

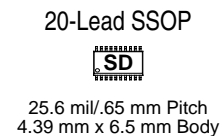
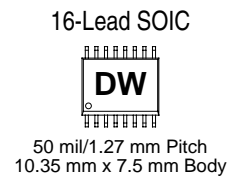
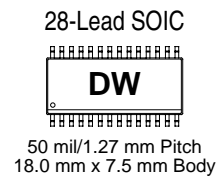
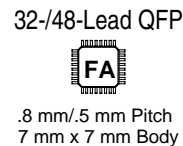
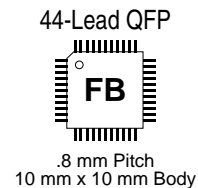
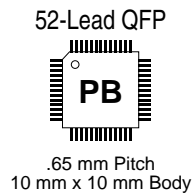
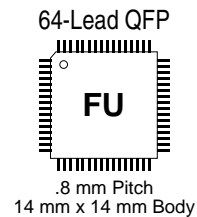

Package Options (Actual Size)

Sheet 2 of 2

48-Pin Plastic DIP

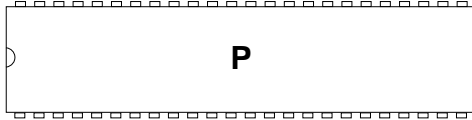

100 mil/2.54 mm Pitch
2.45 in x .55 in Body
(100 mil x 600 mil pin centers)

40-Pin Plastic DIP

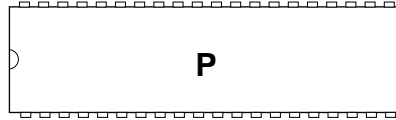

100 mil/2.54 mm Pitch
2.05 in x .55 in Body
(100 mil x 600 mil pin centers)

28-Pin DIP

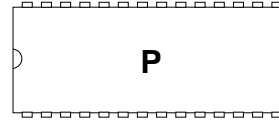

100 mil/2.54 mm Pitch
1.45 in x .55 in Body
(100 mil x 600 mil pin centers)

20-Pin Plastic DIP

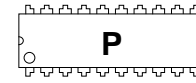

100 mil/2.54 mm Pitch
.97 in x .29 in Body
(100 mil x 300 mil pin centers)

16-Pin Plastic DIP

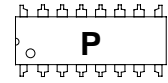

100 mil/2.54 mm Pitch
.75 in x .25 in Body
(100 mil x 300 mil pin centers)

56-Pin Plastic SDIP

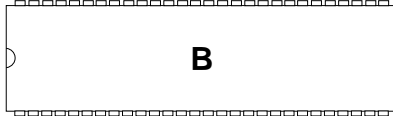

70 mil/1.778 mm Pitch
2.05 in x .55 in Body
(70 mil x 600 mil pin centers)

42-Pin Plastic SDIP

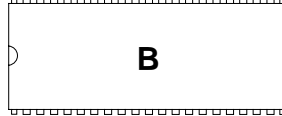

70 mil/1.778 mm Pitch
1.45 in x .55 in Body
(70 mil x 600 mil pin centers)

144-Ball Grid Array (BGA)

VF

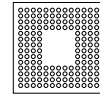

.8 mm Ball Pitch
12 mm x 12 mm x 1.6 mm

Motorola reserves the right to make changes without further notice to any products herein. Motorola makes no warranty, representation or guarantee regarding the suitability of its products for any particular purpose, nor does Motorola assume any liability arising out of the application or use of any product or circuit, and specifically disclaims any and all liability, including without limitation consequential or incidental damages. "Typical" parameters which may be provided in Motorola data sheets and/or specifications can and do vary in different applications and actual performance may vary over time. All operating parameters, including "Typicals" must be validated for each customer application by customer's technical experts. Motorola does not convey any license under its patent rights nor the rights of others. Motorola products are not designed, intended, or authorized for use as components in systems intended for surgical implant into the body, or other applications intended to support or sustain life, or for any other application in which the failure of the Motorola product could create a situation where personal injury or death may occur. Should Buyer purchase or use Motorola products for any such unintended or unauthorized application, Buyer shall indemnify and hold Motorola and its officers, employees, subsidiaries, affiliates, and distributors harmless against all claims, costs, damages, and expenses, and reasonable attorney fees arising out of, directly or indirectly, any claim of personal injury or death associated with such unintended or unauthorized use, even if such claim alleges that Motorola was negligent regarding the design or manufacture of the part. Motorola and  are registered trademarks of Motorola, Inc. Motorola, Inc. is an Equal Opportunity/Affirmative Action Employer.

How to reach us:

USA/EUROPE/Locations Not Listed: Motorola Literature Distribution, P.O. Box 5405, Denver, Colorado 80217, 1-800-441-2447 or 1-303-675-2140. Technical Information Center, 1-800-521-6274

JAPAN: Motorola Japan Ltd.; SPS, Technical Information Center, 3-20-1, Minami-Azabu, Minato-ku, Tokyo 106-8573 Japan. 81-3-3440-8573

ASIA/PACIFIC: Motorola Semiconductors H.K. Ltd.; Silicon Harbour Centre, 2 Dai King Street, Tai Po Industrial Estate, Tai Po, N.T., Hong Kong. 852-26668334

HOME PAGE: <http://motorola.com/semiconductors/>



MOTOROLA

© Motorola, Inc., 2001

SG186/D