

CDC209, CDC209-7 DUAL 1-LINE TO 4-LINE CLOCK DRIVERS WITH 3-STATE OUTPUTS

SCAS108D – MARCH 1990 – REVISED MAY 1997

- CDC209 Replaces 74AC11208
- CDC209-7 Replaces 74AC11208-7
- Low-Skew Propagation Delay Specifications for Clock-Driver Applications
- CMOS-Compatible Inputs and Outputs
- Flow-Through Architecture Optimizes PCB Layout
- Characterized for Operation at 5-V and 3.3-V V_{CC}
- Center-Pin V_{CC} and GND Pin Configurations Minimize High-Speed Switching Noise
- EPIC™ (Enhanced-Performance Implanted CMOS) 1- μ m Process
- 500-mA Typical Latch-Up Immunity at 125°C
- Package Options Include Plastic Small-Outline Package (DW) and Standard Plastic 300-mil DIPs (N)

DW OR N PACKAGE
(TOP VIEW)

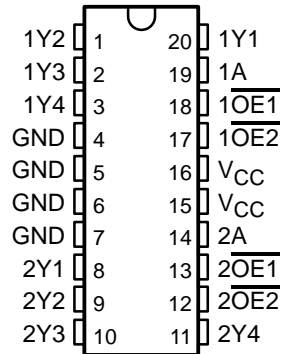

description

The CDC209/209-7 contains dual clock-driver circuits that fanout one input signal to four outputs with minimum skew for clock distribution (see Figure 2). The device also offers two output-enable ($\overline{OE1}$ and $\overline{OE2}$) inputs for each circuit that can force the outputs to be disabled to a high-impedance state or to a high- or low-logic level independent of the signal on the respective A input.

Skew parameters are specified for a reduced temperature and voltage range common to many applications.

The CDC209/209-7 is characterized for operation from $T_A = -40^\circ\text{C}$ to 85°C .

FUNCTION TABLES

INPUTS			OUTPUTS			
$\overline{1OE1}$	$\overline{1OE2}$	1A	1Y1	1Y2	1Y3	1Y4
L	L	L	L	L	L	L
L	L	H	H	H	H	H
L	H	X	L	L	L	L
H	L	X	H	H	H	H
H	H	X	Z	Z	Z	Z

INPUTS			OUTPUTS			
$\overline{2OE1}$	$\overline{2OE2}$	2A	2Y1	2Y2	2Y3	2Y4
L	L	L	L	L	L	L
L	L	H	H	H	H	H
L	H	X	L	L	L	L
H	L	X	H	H	H	H
H	H	X	Z	Z	Z	Z



Please be aware that an important notice concerning availability, standard warranty, and use in critical applications of Texas Instruments semiconductor products and disclaimers thereto appears at the end of this data sheet.

EPIC is a trademark of Texas Instruments Incorporated.

PRODUCTION DATA information is current as of publication date. Products conform to specifications per the terms of Texas Instruments standard warranty. Production processing does not necessarily include testing of all parameters.

**TEXAS
INSTRUMENTS**

POST OFFICE BOX 655303 • DALLAS, TEXAS 75265

Copyright © 1997, Texas Instruments Incorporated

CDC209, CDC209-7 DUAL 1-LINE TO 4-LINE CLOCK DRIVERS WITH 3-STATE OUTPUTS

SCAS108D – MARCH 1990 – REVISED MAY 1997

logic symbol†

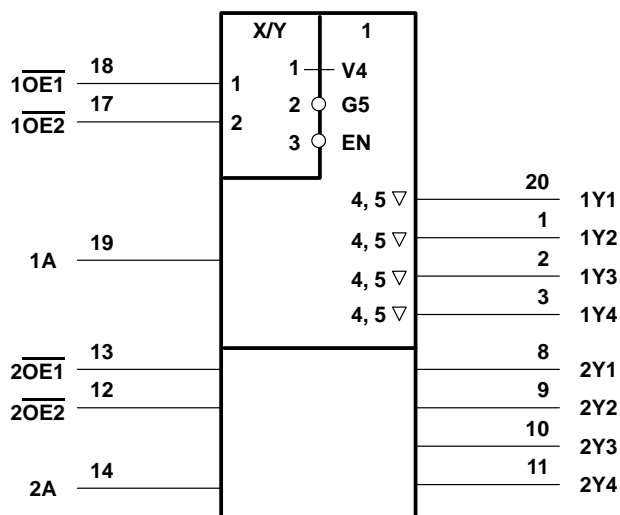

† This symbol is in accordance with ANSI/IEEE Std 91-1984 and IEC Publication 617-12.

logic diagram (positive logic)

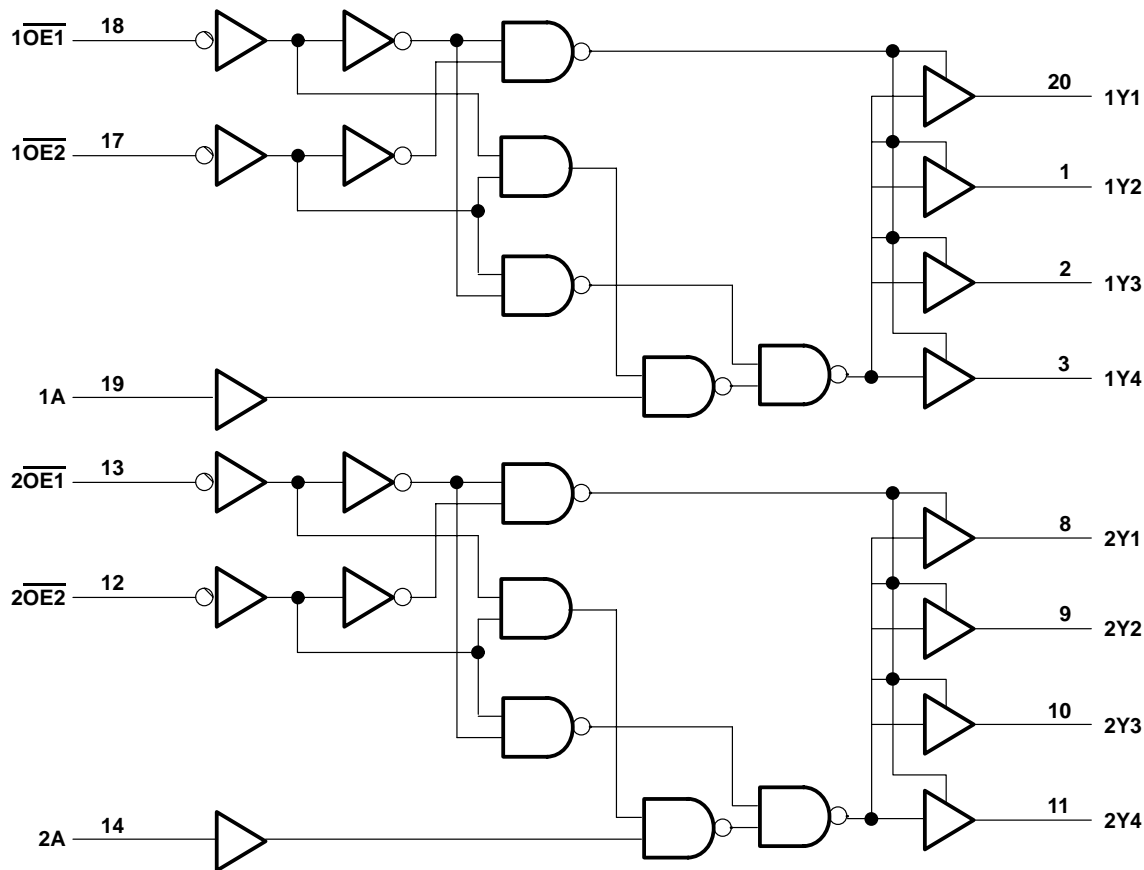

CDC209, CDC209-7 DUAL 1-LINE TO 4-LINE CLOCK DRIVERS WITH 3-STATE OUTPUTS

SCAS108D – MARCH 1990 – REVISED MAY 1997

absolute maximum ratings over operating free-air temperature range (unless otherwise noted)†

Supply voltage range, V_{CC}	-0.5 V to 7 V
Input voltage range, V_I (see Note 1)	-0.5 V to $V_{CC} + 0.5$ V
Output voltage range, V_O (see Note 1)	-0.5 V to $V_{CC} + 0.5$ V
Input clamp current, I_{IK} ($V_I < 0$ or $V_I > V_{CC}$)	± 20 mA
Output clamp current, I_{OK} ($V_O < 0$ or $V_O > V_{CC}$)	± 50 mA
Continuous output current, I_O ($V_O = 0$ to V_{CC})	± 50 mA
Continuous current through V_{CC} or GND	± 200 mA
Maximum power dissipation at $T_A = 55^\circ\text{C}$ (in still air) (see Note 2): DW package	1.6 W
N package	1.3 W
Storage temperature range, T_{stg}	-65°C to 150°C

† Stresses beyond those listed under “absolute maximum ratings” may cause permanent damage to the device. These are stress ratings only, and functional operation of the device at these or any other conditions beyond those indicated under “recommended operating conditions” is not implied. Exposure to absolute-maximum-rated conditions for extended periods may affect device reliability.

- NOTES: 1. The input and output negative-voltage ratings may be exceeded if the input and output clamp-current ratings are observed.
 2. The maximum package power dissipation is calculated using a junction temperature of 150°C and a board trace length of 750 mils, except for the N package, which has a trace length of zero. For more information, refer to the *Package Thermal Considerations* application note in the 1994 *ABT Advanced BiCMOS Technology Data Book*, literature number SCBD002B.

recommended operating conditions

		MIN	NOM	MAX	UNIT
V_{CC}	Supply voltage	3	5	5.5	V
V_{IH}	High-level input voltage	$V_{CC} = 3$ V	2.1		V
		$V_{CC} = 4.5$ V	3.15		
		$V_{CC} = 5.5$ V	3.85		
V_{IL}	Low-level input voltage	$V_{CC} = 3$ V		0.9	V
		$V_{CC} = 4.5$ V		1.35	
		$V_{CC} = 5.5$ V		1.65	
V_I	Input voltage	0		V_{CC}	V
I_{OH}	High-level output current	$V_{CC} = 3$ V		-4	mA
		$V_{CC} = 4.5$ V		-24	
		$V_{CC} = 5.5$ V		-24	
I_{OL}	Low-level output current	$V_{CC} = 3$ V		12	mA
		$V_{CC} = 4.5$ V		24	
		$V_{CC} = 5.5$ V		24	
$\Delta t / \Delta v$	Input transition rise or fall rate	0		10	ns/V
f_{clock}	Input clock frequency			60	MHz
T_A	Operating free-air temperature	-40		85	°C



CDC209, CDC209-7
DUAL 1-LINE TO 4-LINE CLOCK DRIVERS
WITH 3-STATE OUTPUTS

SCAS108D – MARCH 1990 – REVISED MAY 1997

electrical characteristics over recommended operating free-air temperature range (unless otherwise noted)

PARAMETER	TEST CONDITIONS		T _A †	MIN	TYP	MAX	UNIT
V _{OH} High-level output voltage	I _{OH} = -50 μA	V _{CC} = 3 V	25°C	2.9			V
			Full range	2.9			
		V _{CC} = 4.5 V	25°C	4.4			
			Full range	4.4			
		V _{CC} = 5.5 V	25°C	5.4			
			Full range	5.4			
	I _{OH} = -4 mA	V _{CC} = 3 V	25°C	2.58			
			Full range	2.48			
	I _{OH} = -24 mA	V _{CC} = 4.5 V	25°C	3.94			
			Full range	3.8			
V _{CC} = 5.5 V		25°C	4.94				
		Full range	4.8				
I _{OH} = -75 mA‡, V _{CC} = 5.5 V	Full range	3.85					
V _{OL} Low-level output voltage	I _{OL} = 50 μA	V _{CC} = 3 V	25°C			0.1	V
			Full range			0.1	
		V _{CC} = 4.5 V	25°C			0.1	
			Full range			0.1	
		V _{CC} = 5.5 V	25°C			0.1	
			Full range			0.1	
	I _{OL} = 12 mA	V _{CC} = 3 V	25°C			0.36	
			Full range			0.44	
	I _{OL} = 24 mA	V _{CC} = 4.5 V	25°C			0.36	
			Full range			0.44	
		V _{CC} = 5.5 V	25°C			0.36	
			Full range			0.44	
I _{OL} = 75 mA‡, V _{CC} = 5.5 V	Full range			1.65			
I _I Input current	V _I = V _{CC} or GND	V _{CC} = 5.5 V	25°C			±0.1	μA
			Full range			±1	
I _{OZ} High-impedance output current	V _O = V _{CC} or GND	V _{CC} = 5.5 V	25°C			±0.5	μA
			Full range			±5	
I _{CC} Supply current	V _I = V _{CC} or GND, I _O = 0	V _{CC} = 5.5 V	25°C			8	μA
			Full range			80	
C _i Input capacitance	V _I = V _{CC} or GND	V _{CC} = 5 V	25°C		4		pF
C _o Output capacitance	V _O = V _{CC} or GND	V _{CC} = 5 V	25°C		10		pF

† Full range is T_A = -40°C to 85°C.

‡ Not more than one output should be tested at a time, and the duration of the test should not exceed 10 ms.



CDC209, CDC209-7
DUAL 1-LINE TO 4-LINE CLOCK DRIVERS
WITH 3-STATE OUTPUTS

SCAS108D – MARCH 1990 – REVISED MAY 1997

**switching characteristics over recommended operating free-air temperature range,
 $V_{CC} = 3.3\text{ V} \pm 0.3\text{ V}$ (unless otherwise noted) (see Figure 1)**

PARAMETER		FROM (INPUT)	TO (OUTPUT)	T_A †	MIN	TYP	MAX	UNIT
tPLH	Propagation delay time, low-to-high level	1A and 2A	Any Y	25°C	4.8	11.1	13.1	ns
				Full range	4.8		14.6	ns
tPHL	Propagation delay time, high-to-low level	1A and 2A	Any Y	25°C	5.1	12.2	14.3	ns
				Full range	5.1		15.6	ns
tPLH	Propagation delay time, low-to-high level	$\overline{1OE1}$, $\overline{1OE2}$, and $\overline{2OE1}$, $\overline{2OE2}$	Any Y	25°C	5.2	11.9	14.2	ns
				Full range	5.2		15.8	ns
tPHL	Propagation delay time, high-to-low level	$\overline{1OE1}$, $\overline{1OE2}$, and $\overline{2OE1}$, $\overline{2OE2}$	Any Y	25°C	7.8	13.3	15.7	ns
				Full range	7.8		17.4	ns
tPZH	Enable time to the high level	1OE2 or 2OE2	Any Y	25°C	5.1	11.8	14.2	ns
				Full range	5.1		15.7	ns
tPZL	Enable time to the low level	1OE1 or 2OE1	Any Y	25°C	6.8	16.3	19.5	ns
				Full range	6.8		22.8	ns
tPHZ	Disable time from the high level	1OE2 or 2OE2	Any Y	25°C	3.4	6.9	8.6	ns
				Full range	3.4		9.2	ns
tPLZ	Disable time from the low level	1OE1 or 2OE1	Any Y	25°C	4.1	7.5	9.4	ns
				Full range	4.1		10.2	ns

† Full range is $T_A = -40^\circ\text{C}$ to 85°C .

**switching characteristics over recommended operating free-air temperature range,
 $V_{CC} = 5\text{ V} \pm 0.5\text{ V}$ (unless otherwise noted) (see Figure 1)**

PARAMETER		FROM (INPUT)	TO (OUTPUT)	T_A †	MIN	TYP	MAX	UNIT
tPLH	Propagation delay time, low-to-high level	1A and 2A	Any Y	25°C	4.2	5.5	9	ns
				Full range	4.2		9.9	
tPHL	Propagation delay time, high-to-low level	1A and 2A	Any Y	25°C	4.2	7	9.3	ns
				Full range	4.2		10.1	
tPLH	Propagation delay time, low-to-high level	$\overline{1OE1}$, $\overline{1OE2}$, and $\overline{2OE1}$, $\overline{2OE2}$	Any Y	25°C	4.6	7.3	9.6	ns
				Full range	4.6		10.7	
tPHL	Propagation delay time, high-to-low level	$\overline{1OE1}$, $\overline{1OE2}$, and $\overline{2OE1}$, $\overline{2OE2}$	Any Y	25°C	4.8	7.7	10.2	ns
				Full range	4.8		11	
tPZH	Enable time to the high level	1OE2 or 2OE2	Any Y	25°C	4.3	7.2	9.4	ns
				Full range	4.3		4	
tPZL	Enable time to the low level	1OE1 or 2OE1	Any Y	25°C	5.3	9	12.2	ns
				Full range	5.3		13.5	
tPHZ	Disable time from the high level	1OE2 or 2OE2	Any Y	25°C	3	5.4	7.5	ns
				Full range	3		8	
tPLZ	Disable time from the low level	1OE1 or 2OE1	Any Y	25°C	3.7	5.7	7.5	ns
				Full range	3.7		8.2	

† Full range is $T_A = -40^\circ\text{C}$ to 85°C .



CDC209, CDC209-7 DUAL 1-LINE TO 4-LINE CLOCK DRIVERS WITH 3-STATE OUTPUTS

SCAS108D – MARCH 1990 – REVISED MAY 1997

switching characteristics, $V_{CC} = 5\text{ V} \pm 0.25\text{ V}$, $T_A = 25^\circ\text{C}$ to 70°C (see Note 3 and Figures 1 and 2)

PARAMETER	FROM (INPUT)	TO (OUTPUT)	CDC209		CDC209-7		UNIT
			MIN	MAX	MIN	MAX	
t_{PLH} Propagation delay time, low-to-high level	1A and 2A	Any Y	6	8.5	6	8.5	ns
t_{PHL} Propagation delay time, high-to-low level			6	9.3	6	9.3	
$t_{sk(o)}$ output skew time	1A and 2A	Any Y	1		0.7		ns

NOTE 3: All specifications are valid only for all outputs switching simultaneously and in phase.

operating characteristics, $V_{CC} = 5\text{ V}$, $T_A = 25^\circ\text{C}$

PARAMETER		TEST CONDITIONS	MIN	TYP	MAX	UNIT
C_{pd} Power dissipation capacitance per bank	Outputs enabled					
	Outputs disabled	10				

PARAMETER MEASUREMENT INFORMATION

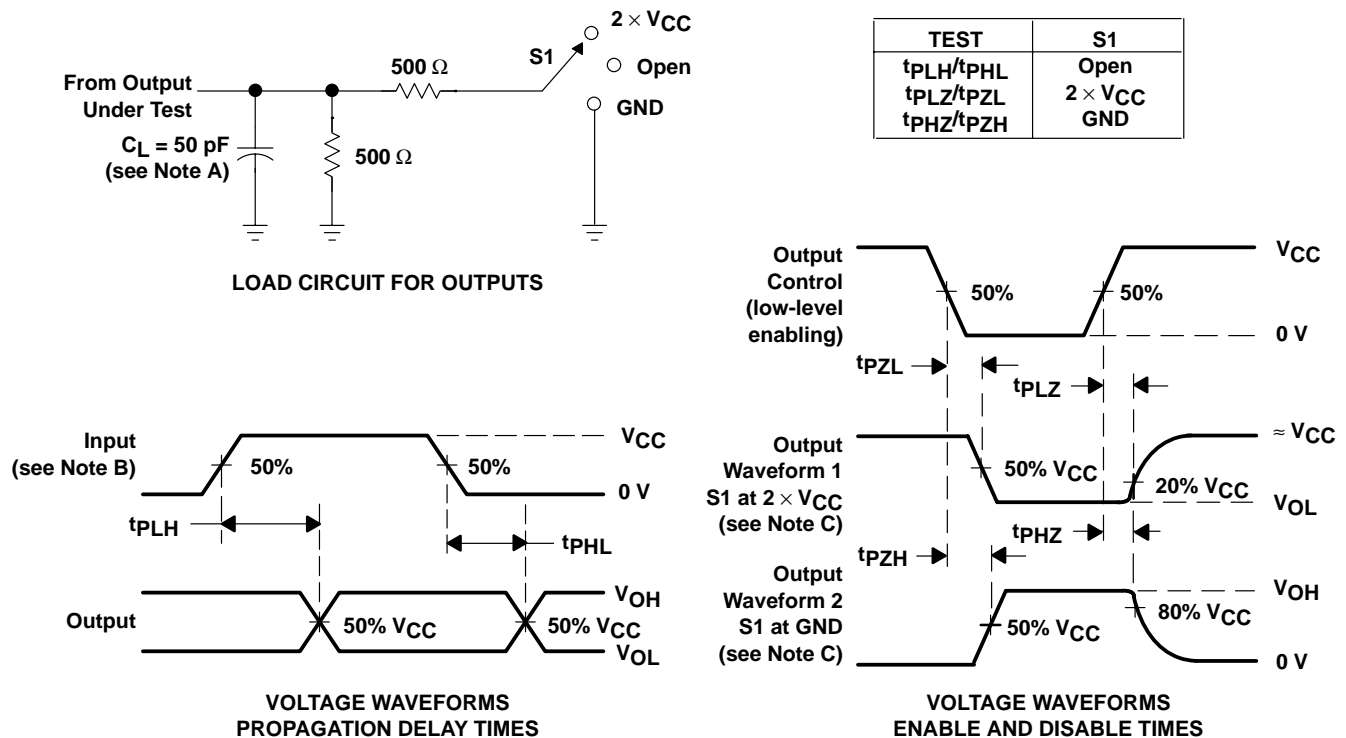

- NOTES: A. C_L includes probe and jig capacitance.
 B. All input pulses are supplied by generators having the following characteristics: $PRR \leq 10\text{ MHz}$, $Z_O = 50\ \Omega$, $t_r \leq 3\text{ ns}$, $t_f \leq 3\text{ ns}$. For testing pulse duration: $t_r = t_f = 1\text{ to }3\text{ ns}$. Pulse polarity can be either high-to-low-to-high or low-to-high-to-low.
 C. Waveform 1 is for an output with internal conditions such that the output is low except when disabled by the output control. Waveform 2 is for an output with internal conditions such that the output is high except when disabled by the output control.

Figure 1. Load Circuit and Voltage Waveforms

PARAMETER MEASUREMENT INFORMATION

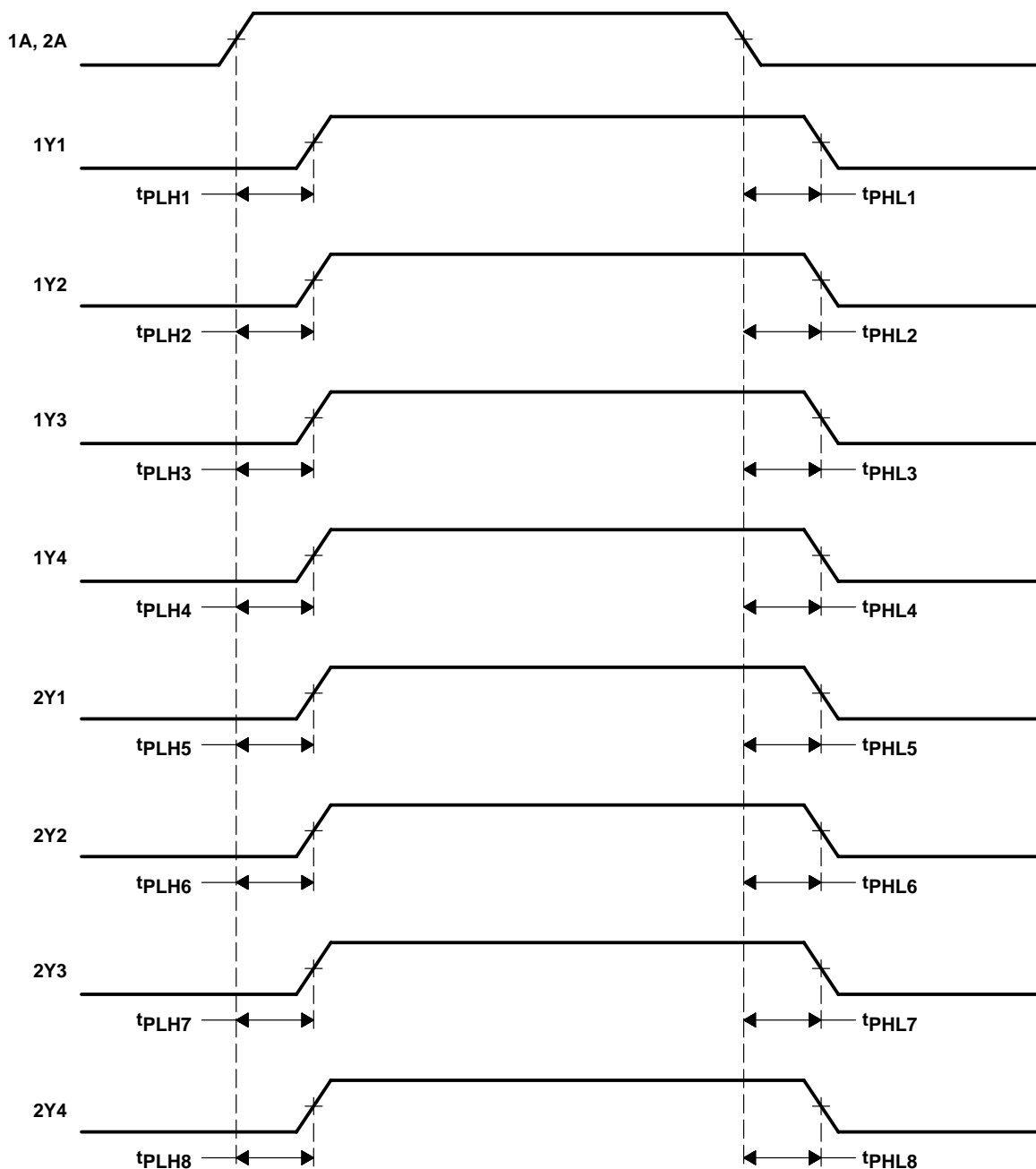

NOTE D: Output skew, $t_{sk(o)}$, is calculated as the greater of:
 - The difference between the fastest and slowest of t_{PLHn} ($n = 1, 2, \dots, 8$)
 - The difference between the fastest and slowest of t_{PHLn} ($n = 1, 2, \dots, 8$)

Figure 2. Waveforms for Calculation of $t_{sk(o)}$

CDC209, CDC209-7
DUAL 1-LINE TO 4-LINE CLOCK DRIVERS
WITH 3-STATE OUTPUTS

SCAS108D – MARCH 1990 – REVISED MAY 1997

MECHANICAL INFORMATION

DW (R-PDSO-G)**

PLASTIC SMALL-OUTLINE PACKAGE

16 PIN SHOWN

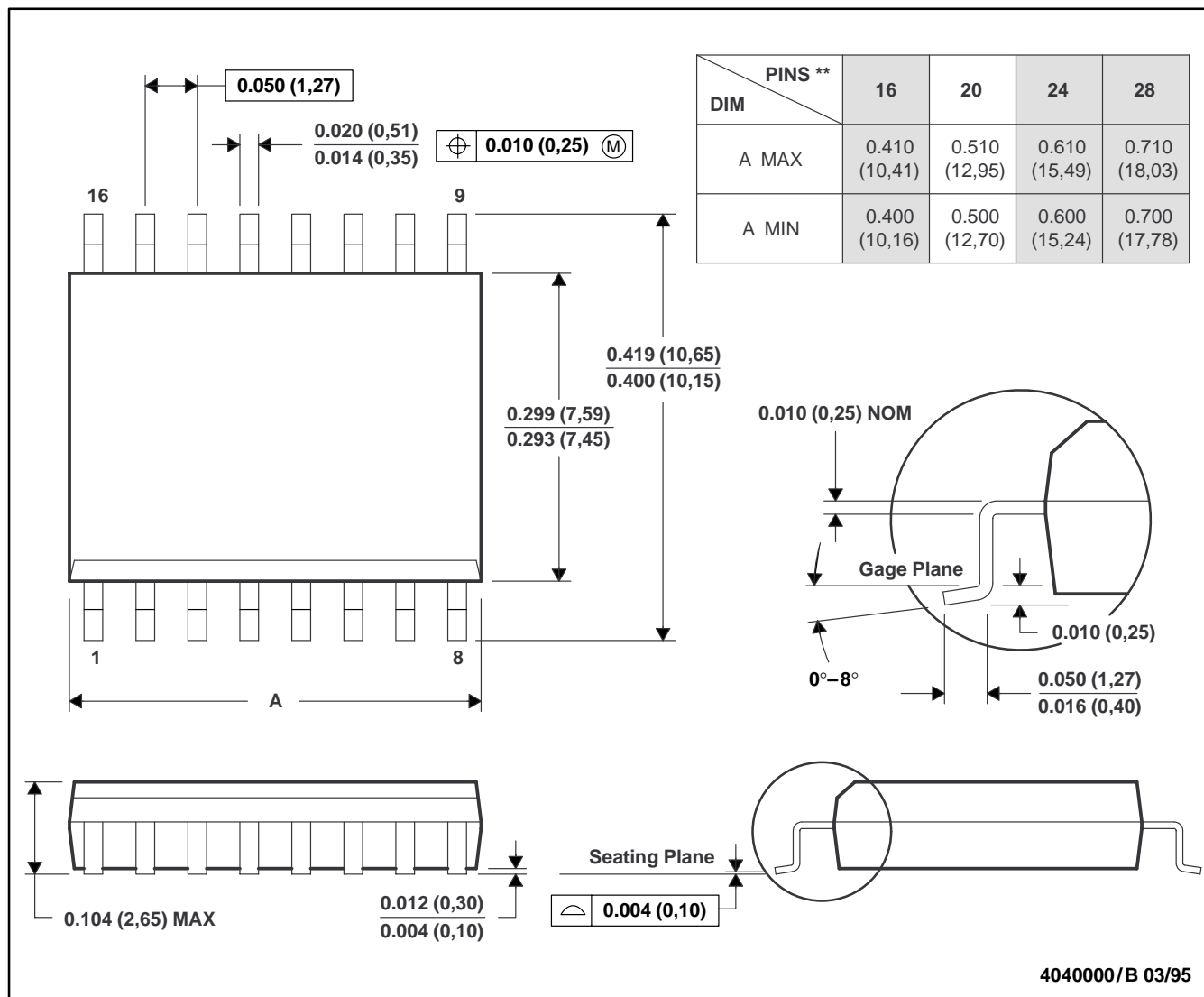

- NOTES: A. All linear dimensions are in inches (millimeters).
 B. This drawing is subject to change without notice.
 C. Body dimensions do not include mold flash or protrusion not to exceed 0.006 (0,15).
 D. Falls within JEDEC MS-013

CDC209, CDC209-7 DUAL 1-LINE TO 4-LINE CLOCK DRIVERS WITH 3-STATE OUTPUTS

SCAS108D - MARCH 1990 - REVISED MAY 1997

MECHANICAL INFORMATION

N (R-PDIP-T)**

PLASTIC DUAL-IN-LINE PACKAGE

16 PIN SHOWN

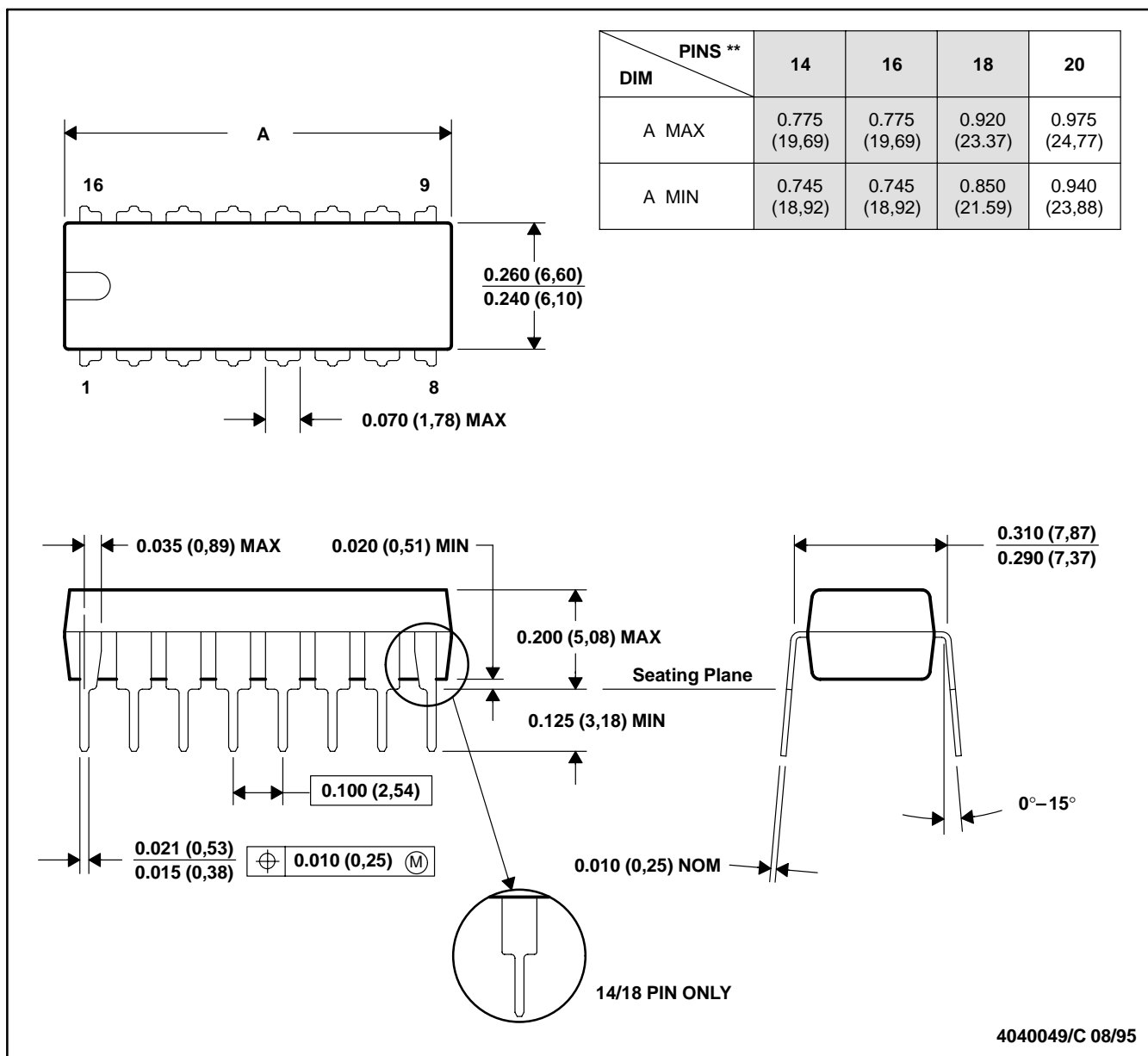

- NOTES: A. All linear dimensions are in inches (millimeters).
 B. This drawing is subject to change without notice.
 C. Falls within JEDEC MS-001 (20 pin package is shorter than MS-001.)

IMPORTANT NOTICE

Texas Instruments (TI) reserves the right to make changes to its products or to discontinue any semiconductor product or service without notice, and advises its customers to obtain the latest version of relevant information to verify, before placing orders, that the information being relied on is current.

TI warrants performance of its semiconductor products and related software to the specifications applicable at the time of sale in accordance with TI's standard warranty. Testing and other quality control techniques are utilized to the extent TI deems necessary to support this warranty. Specific testing of all parameters of each device is not necessarily performed, except those mandated by government requirements.

Certain applications using semiconductor products may involve potential risks of death, personal injury, or severe property or environmental damage ("Critical Applications").

TI SEMICONDUCTOR PRODUCTS ARE NOT DESIGNED, INTENDED, AUTHORIZED, OR WARRANTED TO BE SUITABLE FOR USE IN LIFE-SUPPORT APPLICATIONS, DEVICES OR SYSTEMS OR OTHER CRITICAL APPLICATIONS.

Inclusion of TI products in such applications is understood to be fully at the risk of the customer. Use of TI products in such applications requires the written approval of an appropriate TI officer. Questions concerning potential risk applications should be directed to TI through a local SC sales office.

In order to minimize risks associated with the customer's applications, adequate design and operating safeguards should be provided by the customer to minimize inherent or procedural hazards.

TI assumes no liability for applications assistance, customer product design, software performance, or infringement of patents or services described herein. Nor does TI warrant or represent that any license, either express or implied, is granted under any patent right, copyright, mask work right, or other intellectual property right of TI covering or relating to any combination, machine, or process in which such semiconductor products or services might be or are used.