

CDC2536

3.3-V PHASE-LOCK LOOP CLOCK DRIVER WITH 3-STATE OUTPUTS

SCAS377D – APRIL 1994 – REVISED OCTOBER 1998

- Low Output Skew for Clock-Distribution and Clock-Generation Applications
- Operates at 3.3-V V_{CC}
- Distributes One Clock Input to Six Outputs
- One Select Input Configures Three Outputs to Operate at One-Half or Double the Input Frequency
- No External RC Network Required
- On-Chip Series Damping Resistors
- External Feedback Pin (FBIN) Is Used to Synchronize the Outputs to the Clock Input
- Application for Synchronous DRAM, High-Speed Microprocessor
- TTL-Compatible Inputs and Outputs
- Outputs Drive 50- Ω Parallel-Terminated Transmission Lines
- State-of-the-Art EPIC-IIB™ BiCMOS Design Significantly Reduces Power Dissipation
- Distributed V_{CC} and Ground Pins Reduce Switching Noise
- Packaged in Plastic 28-Pin Shrink Small-Outline Package

DB PACKAGE
(TOP VIEW)

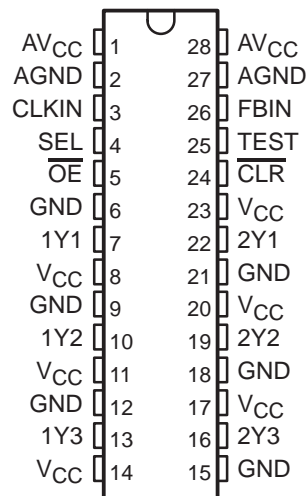

description

The CDC2536 is a high-performance, low-skew, low-jitter clock driver. It uses a phase-lock loop (PLL) to precisely align, in both frequency and phase, the clock output signals to the clock input (CLKIN) signal. It is specifically designed for use with synchronous DRAMs and popular microprocessors operating at speeds from 50 MHz to 100 MHz or down to 25 MHz on outputs configured as half-frequency outputs. The CDC2536 operates at 3.3-V V_{CC} and is designed to drive a 50- Ω transmission line. The CDC2536 also provides on-chip series-damping resistors, eliminating the need for external termination components.

The feedback (FBIN) input is used to synchronize the output clocks in frequency and phase to the input clock (CLKIN). One of the six output clocks must be fed back to FBIN for the PLL to maintain synchronization between CLKIN and the outputs. The output used as the feedback pin is synchronized to the same frequency as CLKIN.

The Y outputs can be configured to switch in phase and at the same frequency as CLKIN. The select (SEL) input configures three Y outputs to operate at one-half or double the CLKIN frequency, depending on which pin is fed back to FBIN (see Tables 1 and 2). All output signal duty cycles are adjusted to 50% independent of the duty cycle at the input clock.

Output-enable (\overline{OE}) is provided for output control. When \overline{OE} is high, the outputs are in the high-impedance state. When \overline{OE} is low, the outputs are active. TEST is used for factory testing of the device and can be used to bypass the PLL. TEST should be strapped to GND for normal operation.



Please be aware that an important notice concerning availability, standard warranty, and use in critical applications of Texas Instruments semiconductor products and disclaimers thereto appears at the end of this data sheet.

EPIC-IIB is a trademark of Texas Instruments Incorporated.

PRODUCTION DATA information is current as of publication date. Products conform to specifications per the terms of Texas Instruments standard warranty. Production processing does not necessarily include testing of all parameters.

 **TEXAS
INSTRUMENTS**

POST OFFICE BOX 655303 • DALLAS, TEXAS 75265

Copyright © 1998, Texas Instruments Incorporated

CDC2536

3.3-V PHASE-LOCK LOOP CLOCK DRIVER

WITH 3-STATE OUTPUTS

SCAS377D – APRIL 1994 – REVISED OCTOBER 1998

description (continued)

Unlike many products containing PLLs, the CDC2536 does not require external RC networks. The loop filter for the PLL is included on-chip, minimizing component count, board space, and cost.

Because it is based on PLL circuitry, the CDC2536 requires a stabilization time to achieve phase lock of the feedback signal to the reference signal. This stabilization time is required following power up and application of a fixed-frequency, fixed-phase signal at CLKIN, as well as following any changes to the PLL reference or feedback signals. Such changes occur upon change of SEL, enabling the PLL via TEST, and upon enable of all outputs via \overline{OE} .

The CDC2536 is characterized for operation from 0°C to 70°C.

detailed description of output configurations

The voltage-controlled oscillator (VCO) used in the CDC2536 has a frequency range of 100 MHz to 200 MHz, twice the operating frequency of the CDC2536 outputs. The output of the VCO is divided by two and by four to provide reference frequencies with a 50% duty cycle of one-half and one-fourth the VCO frequency. SEL determines which of the two signals is buffered to each bank of device outputs.

One device output must be externally wired to FBIN to complete the PLL. The VCO operates such that the frequency of the output matches that of CLKIN. In the case that a VCO/2 output is wired to FBIN, the VCO must operate at twice the CLKIN frequency resulting in device outputs that operate at either the same or one-half the CLKIN frequency. If a VCO/4 output is wired to FBIN, the device outputs operate at the same or twice the CLKIN frequency.

output configuration A

Output configuration A is valid when any output configured as a 1× frequency output in Table 1 is fed back to FBIN. The input frequency range for CLKIN is 50 MHz to 100 MHz when using output configuration A. Outputs configured as 1/2× outputs operate at half the CLKIN frequency, while outputs configured as 1× outputs operate at the same frequency as CLKIN.

Table 1. Output Configuration A

INPUT SEL	OUTPUTS	
	1/2× FREQUENCY	1× FREQUENCY
L	None	All
H	1Yn	2Yn

NOTE: n = 1, 2, 3

output configuration B

Output configuration B is valid when any output configured as a 1× frequency output in Table 2 is fed back to FBIN. The input frequency range for CLKIN is 25 MHz to 50 MHz when using output configuration B. Outputs configured as 1× outputs operate at the CLKIN frequency, while outputs configured as 2× outputs operate at double the frequency of CLKIN.

Table 2. Output Configuration B

INPUT SEL	OUTPUTS	
	1× FREQUENCY	2× FREQUENCY
H	1Yn	2Yn
L	All	None

NOTE: n = 1, 2, 3



CDC2536
3.3-V PHASE-LOCK LOOP CLOCK DRIVER
WITH 3-STATE OUTPUTS

SCAS377D – APRIL 1994 – REVISED OCTOBER 1998

functional block diagram

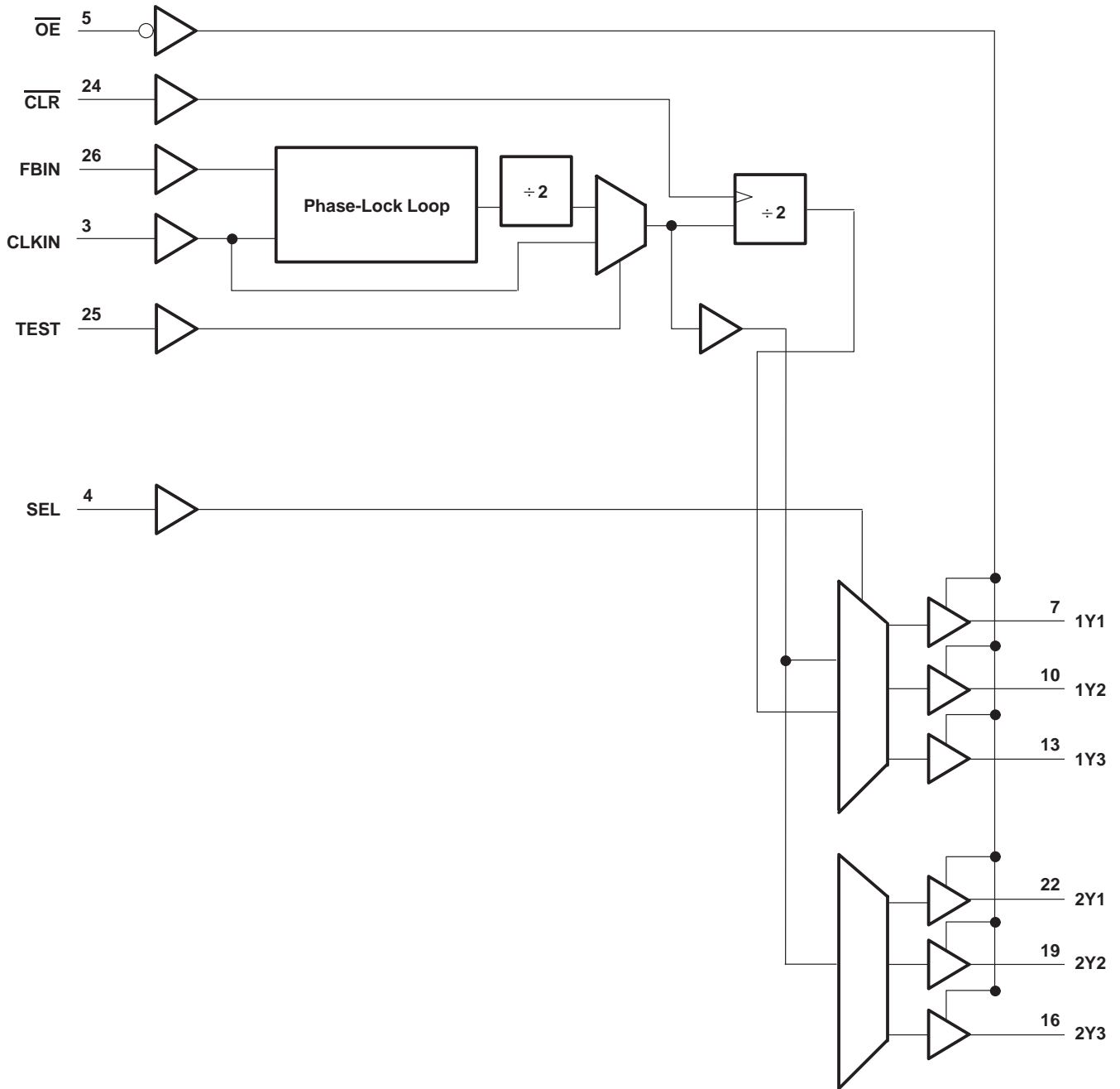

CDC2536
3.3-V PHASE-LOCK LOOP CLOCK DRIVER
WITH 3-STATE OUTPUTS

SCAS377D – APRIL 1994 – REVISED OCTOBER 1998

Terminal Functions

TERMINAL NAME	NO.	I/O	DESCRIPTION
CLKIN	3	I	Clock input. CLKIN provides the clock signal to be distributed by the CDC2536 clock-driver circuit. CLKIN provides the reference signal to the integrated PLL that generates the clock output signals. CLKIN must have a fixed frequency and fixed phase for the phase-lock loop to obtain phase lock. Once the circuit is powered up and a valid CLKIN signal is applied, a stabilization time is required for the PLL to phase lock the feedback signal to its reference signal.
$\overline{\text{CLR}}$	24	I	$\overline{\text{CLR}}$ is used for testing purposes only.
FBIN	26	I	Feedback input. FBIN provides the feedback signal to the internal PLL. FBIN must be hardwired to one of the six clock outputs to provide frequency and phase lock. The internal PLL adjusts the output clocks to obtain zero phase delay between the FBIN and differential CLKIN inputs.
$\overline{\text{OE}}$	5	I	Output enable. $\overline{\text{OE}}$ is the output enable for all outputs. When $\overline{\text{OE}}$ is low, all outputs are enabled. When $\overline{\text{OE}}$ is high, all outputs are in the high-impedance state. Since the feedback signal for the PLL is taken directly from an output, placing the outputs in the high-impedance state interrupts the feedback loop; therefore, when a high-to-low transition occurs at $\overline{\text{OE}}$, enabling the output buffers, a stabilization time is required before the PLL obtains phase lock.
SEL	4	I	Output configuration select. SEL selects the output configuration for each output bank (e.g. 1×, 1/2×, or 2×). (see Tables 1 and 2).
TEST	25	I	TEST is used to bypass the PLL circuitry for factory testing of the device. When TEST is low, all outputs operate using the PLL circuitry. When TEST is high, the outputs are placed in a test mode that bypasses the PLL circuitry. TEST should be grounded for normal operation.
1Y1–1Y3	7, 10, 13	O	These outputs are configured by SEL to transmit one-half or one-fourth the frequency of the VCO. The relationship between the CLKIN frequency and the output frequency is dependent on SEL. The duty cycle of the Y output signals is nominally 50%, independent of the duty cycle of the CLKIN signal. Each output has an internal series resistor to dampen transmission-line effects and improve the signal integrity at the load.
2Y1–2Y3	22, 19, 16	O	These outputs transmit one-half the frequency of the VCO. The relationship between the CLKIN frequency and the output frequency is dependent on the frequency of the output being fed back to FBIN. The duty cycle of the Y output signals is nominally 50%, independent of the duty cycle of the CLKIN signal. Each output has an internal series resistor to dampen transmission-line effects and improve the signal integrity at the load.



CDC2536
**3.3-V PHASE-LOCK LOOP CLOCK DRIVER
 WITH 3-STATE OUTPUTS**

SCAS377D – APRIL 1994 – REVISED OCTOBER 1998

absolute maximum ratings over operating free-air temperature range (unless otherwise noted)†

Supply voltage range, V_{CC}	-0.5 V to 4.6 V
Input voltage range, V_I (see Note 1)	-0.5 V to 7 V
Voltage range applied to any output in the high state or power-off state, V_O (see Note 1) ...	-0.5 V to 5.5 V
Current into any output in the low state, I_O	24 mA
Input clamp current, I_{IK} ($V_I < 0$)	-20 mA
Output clamp current, I_{OK} ($V_O < 0$)	-50 mA
Maximum power dissipation at $T_A = 55^\circ\text{C}$ (in still air) (see Note 2)	0.68 W
Storage temperature range, T_{stg}	-65°C to 150°C

† Stresses beyond those listed under “absolute maximum ratings” may cause permanent damage to the device. These are stress ratings only, and functional operation of the device at these or any other conditions beyond those indicated under “recommended operating conditions” is not implied. Exposure to absolute-maximum-rated conditions for extended periods may affect device reliability.

- NOTES: 1. The input and output negative-voltage ratings may be exceeded if the input and output clamp-current ratings are observed.
 2. The maximum package power dissipation is calculated using a junction temperature of 150°C and a board trace length of 75 mils.
 For more information, refer to the *Package Thermal Considerations* application note in the 1994 *ABT Advanced BiCMOS Technology Data Book*, literature number SCBD002B.

recommended operating conditions (see Note 3)

		MIN	MAX	UNIT
V_{CC}	Supply voltage	3	3.6	V
V_{IH}	High-level input voltage	2		V
V_{IL}	Low-level input voltage		0.8	V
V_I	Input voltage	0	5.5	V
I_{OH}	High-level output current		-12	mA
I_{OL}	Low-level output current		12	mA
T_A	Operating free-air temperature	0	70	°C

NOTE 3: Unused inputs must be held high or low to prevent them from floating.

electrical characteristics over recommended operating free-air temperature range (unless otherwise noted)

PARAMETER	TEST CONDITIONS	$T_A = 25^\circ\text{C}$		UNIT
		MIN	MAX	
V_{IK}	$V_{CC} = 3\text{ V}$, $I_I = -18\text{ mA}$		-1.2	V
V_{OH}	$V_{CC} = \text{MIN to MAX}^\ddagger$, $I_{OH} = -100\ \mu\text{A}$	$V_{CC} - 0.2$		V
	$V_{CC} = 3\text{ V}$, $I_{OH} = -12\text{ mA}$	2		
V_{OL}	$V_{CC} = 3\text{ V}$, $I_{OL} = 100\ \mu\text{A}$	0.2		V
	$V_{CC} = 3\text{ V}$, $I_{OL} = 12\text{ mA}$	0.8		
I_I	$V_{CC} = 0\text{ or MAX}^\ddagger$, $V_I = 3.6\text{ V}$	± 10		μA
	$V_{CC} = 3.6\text{ V}$, $V_I = V_{CC}\text{ or GND}$	± 1		
I_{OZH}	$V_{CC} = 3.6\text{ V}$, $V_O = 3\text{ V}$	10		μA
I_{OZL}	$V_{CC} = 3.6\text{ V}$, $V_O = 0$	-10		μA
I_{CC}	$V_{CC} = 3.6\text{ V}$, $V_I = V_{CC}\text{ or GND}$ $I_O = 0$,	Outputs high	2	mA
		Outputs low	2	
		Outputs disabled	2	
C_i	$V_I = V_{CC}\text{ or GND}$	6		pF
C_o	$V_O = V_{CC}\text{ or GND}$	9		pF

‡ For conditions shown as MIN or MAX, use the appropriate value specified under recommended operating conditions.



CDC2536
3.3-V PHASE-LOCK LOOP CLOCK DRIVER
WITH 3-STATE OUTPUTS

SCAS377D – APRIL 1994 – REVISED OCTOBER 1998

timing requirements over recommended ranges of supply voltage and operating free-air temperature

		MIN	MAX	UNIT	
f _{clock}	Clock frequency	When VCO is operating at four times the CLKIN frequency	25	50	MHz
		When VCO is operating at double the CLKIN frequency	50	100	
Duty cycle, CLKIN		40%	60%		
Stabilization time†	After SEL		50	μs	
	After OE↓		50		
	After power up		50		
	After CLKIN		50		

† Time required for the integrated PLL circuit to obtain phase lock of its feedback signal to its reference signal. For phase lock to be obtained, a fixed-frequency, fixed-phase reference signal must be present at CLKIN. Until phase lock is obtained, the specifications for propagation delay and skew parameters given in the switching characteristics table are not applicable.

switching characteristics over recommended ranges of supply voltage and operating free-air temperature, C_L = 15 pF (see Note 4 and Figures 1, 2 and 3)

PARAMETER	FROM (INPUT)	TO (OUTPUT)	MIN	MAX	UNIT
f _{max}			100		MHz
Duty cycle		Y	45%	55%	
t _{phase error} ‡	CLKIN↑	Y↑	-500	+500	ps
t _{jitter (RMS)}	CLKIN↑	Y↑		200	ps
t _{sk(o)} ‡				0.5	ns
t _{sk(pr)} ‡				1	ns
t _r				1.4	ns
t _f				1.4	ns

‡ The propagation delay, t_{phase error}, is dependent on the feedback path from any output to FBIN. The t_{phase error}, t_{sk(o)}, and t_{sk(pr)} specifications are only valid for equal loading of all outputs.

NOTE 4: The specifications for parameters in this table are applicable only after any appropriate stabilization time has elapsed.

PARAMETER MEASUREMENT INFORMATION

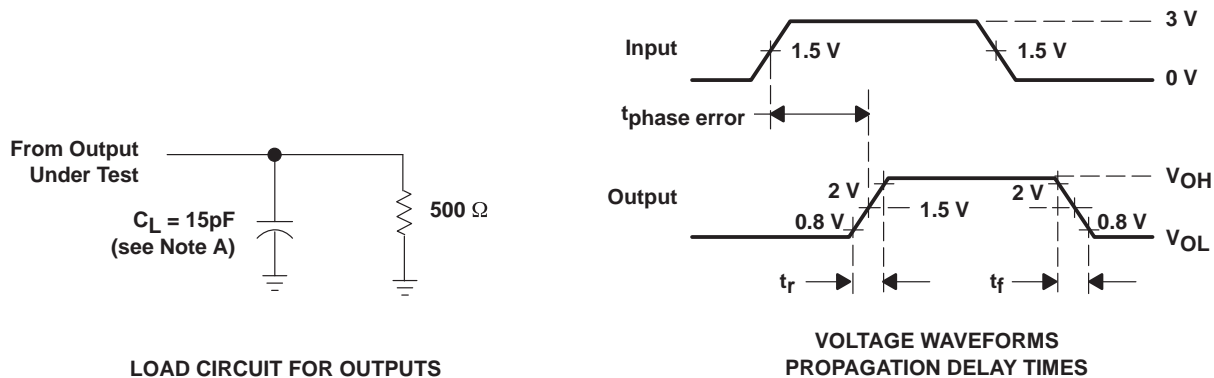

- NOTES: A. C_L includes probe and jig capacitance.
 B. All input pulses are supplied by generators having the following characteristics: PRR ≤ 100 MHz, Z_O = 50 Ω, t_r ≤ 2.5 ns, t_f ≤ 2.5 ns.
 C. The outputs are measured one at a time with one transition per measurement.

Figure 1. Load Circuit and Voltage Waveforms



PARAMETER MEASUREMENT INFORMATION

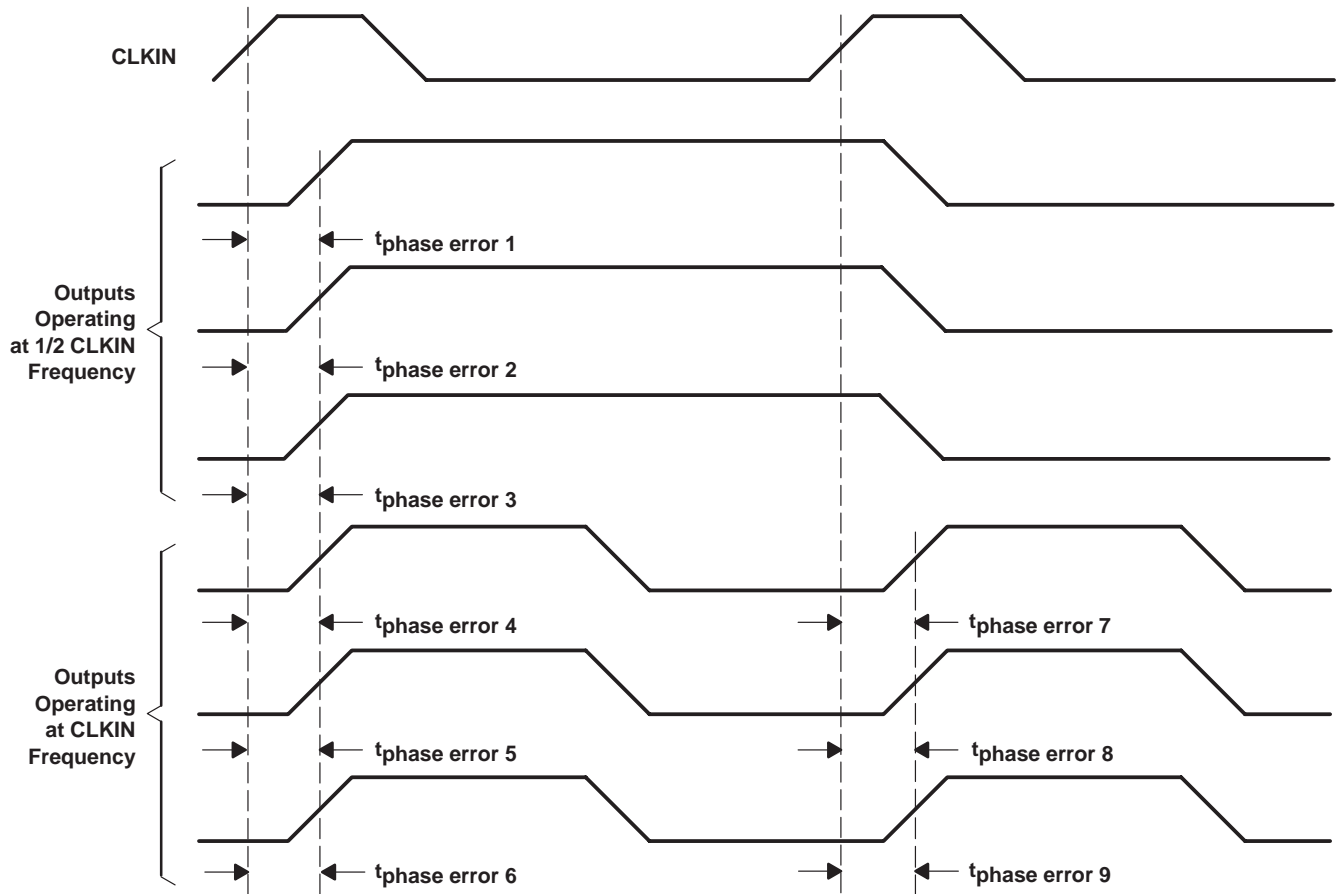

- NOTES: A. Output skew, $t_{sk(o)}$, is calculated as the greater of:
- The difference between the fastest and slowest of $t_{phase\ error\ n}$ ($n = 1, 2, \dots 6$)
 - The difference between the fastest and slowest of $t_{phase\ error\ n}$ ($n = 7, 8, 9$)
- B. Process skew, $t_{sk(pr)}$, is calculated as the greater of:
- The difference between the maximum and minimum $t_{phase\ error\ n}$ ($n = 1, 2, \dots 6$) across multiple devices under identical operating conditions
 - The difference between the maximum and minimum $t_{phase\ error\ n}$ ($n = 7, 8, 9$) across multiple devices under identical operating conditions

Figure 2. Waveforms for Calculations of $t_{sk(o)}$ and $t_{sk(pr)}$

CDC2536
3.3-V PHASE-LOCK LOOP CLOCK DRIVER
WITH 3-STATE OUTPUTS

SCAS377D – APRIL 1994 – REVISED OCTOBER 1998

PARAMETER MEASUREMENT INFORMATION

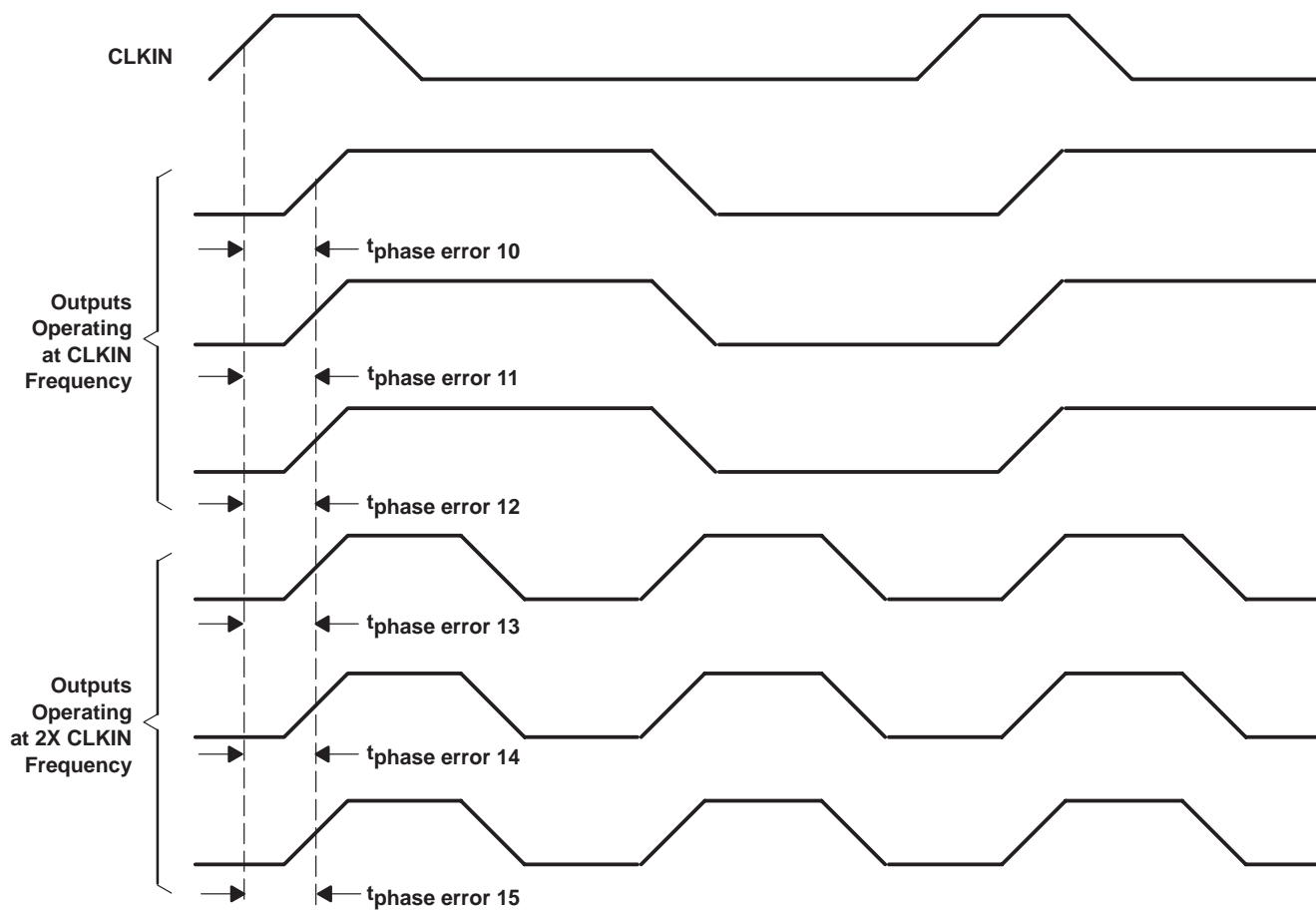

- NOTES: A. Output skew, $t_{sk(o)}$, is calculated as the greater of:
- The difference between the fastest and slowest of $t_{phase\ error\ n}$ ($n = 10, 11, \dots, 15$)
- B. Process skew, $t_{sk(pr)}$, is calculated as the greater of:
- The difference between the maximum and minimum $t_{phase\ error\ n}$ ($n = 10, 11, \dots, 15$) across multiple devices under identical operating conditions.

Figure 3. Waveforms for Calculation of $t_{sk(o)}$ and $t_{sk(pr)}$

MECHANICAL INFORMATION

DB (R-PDSO-G)**

PLASTIC SMALL-OUTLINE PACKAGE

28 PIN SHOWN

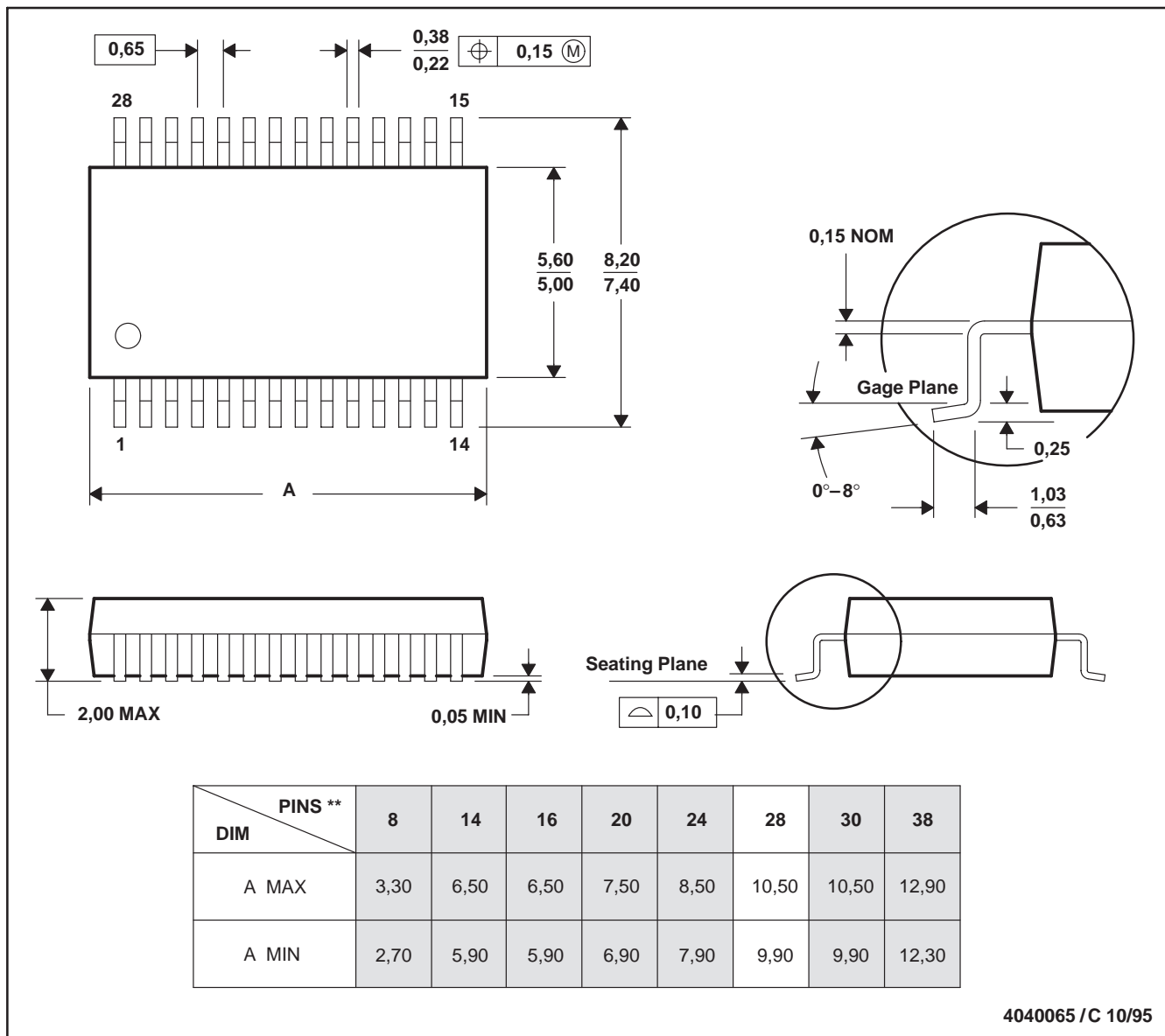

- NOTES: A. All linear dimensions are in millimeters.
 B. This drawing is subject to change without notice.
 C. Body dimensions do not include mold flash or protrusion not to exceed 0,15.
 D. Falls within JEDEC MO-150

IMPORTANT NOTICE

Texas Instruments and its subsidiaries (TI) reserve the right to make changes to their products or to discontinue any product or service without notice, and advise customers to obtain the latest version of relevant information to verify, before placing orders, that information being relied on is current and complete. All products are sold subject to the terms and conditions of sale supplied at the time of order acknowledgement, including those pertaining to warranty, patent infringement, and limitation of liability.

TI warrants performance of its semiconductor products to the specifications applicable at the time of sale in accordance with TI's standard warranty. Testing and other quality control techniques are utilized to the extent TI deems necessary to support this warranty. Specific testing of all parameters of each device is not necessarily performed, except those mandated by government requirements.

CERTAIN APPLICATIONS USING SEMICONDUCTOR PRODUCTS MAY INVOLVE POTENTIAL RISKS OF DEATH, PERSONAL INJURY, OR SEVERE PROPERTY OR ENVIRONMENTAL DAMAGE ("CRITICAL APPLICATIONS"). TI SEMICONDUCTOR PRODUCTS ARE NOT DESIGNED, AUTHORIZED, OR WARRANTED TO BE SUITABLE FOR USE IN LIFE-SUPPORT DEVICES OR SYSTEMS OR OTHER CRITICAL APPLICATIONS. INCLUSION OF TI PRODUCTS IN SUCH APPLICATIONS IS UNDERSTOOD TO BE FULLY AT THE CUSTOMER'S RISK.

In order to minimize risks associated with the customer's applications, adequate design and operating safeguards must be provided by the customer to minimize inherent or procedural hazards.

TI assumes no liability for applications assistance or customer product design. TI does not warrant or represent that any license, either express or implied, is granted under any patent right, copyright, mask work right, or other intellectual property right of TI covering or relating to any combination, machine, or process in which such semiconductor products or services might be or are used. TI's publication of information regarding any third party's products or services does not constitute TI's approval, warranty or endorsement thereof.