

CDC509 3.3-V PHASE-LOCK LOOP CLOCK DRIVER

SCAS576B – JULY 1996 – REVISED JANUARY 1998

- Phase-Lock Loop Clock Distribution for Synchronous DRAM Applications
- Distributes One Clock Input to One Bank of Five and One Bank of Four Outputs
- Separate Output Enable for Each Output Bank
- External Feedback (FBIN) Pin Is Used to Synchronize the Outputs to the Clock Input
- No External RC Network Required
- Operates at 3.3-V V_{CC}
- Packaged in Plastic 24-Pin Thin Shrink Small-Outline Package

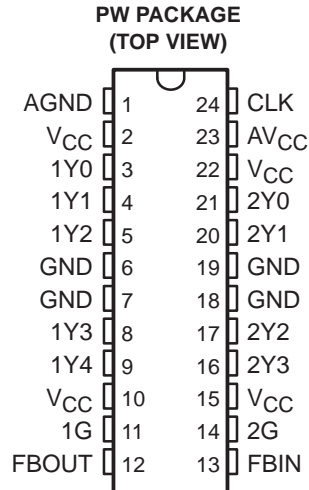

description

The CDC509 is a high-performance, low-skew, low-jitter, phase-lock loop (PLL) clock driver. It uses a PLL to precisely align, in both frequency and phase, the feedback (FBOUT) output to the clock (CLK) input signal. It is specifically designed for use with synchronous DRAMs. The CDC509 operates at 3.3-V V_{CC} and is designed to drive up to five clock loads per output.

One bank of five outputs and one bank of four outputs provide nine low-skew, low-jitter copies of CLK. Output signal duty cycles are adjusted to 50 percent, independent of the duty cycle at CLK. Each bank of outputs can be enabled or disabled separately via the control (1G and 2G) inputs. When the G inputs are high, the outputs switch in phase and frequency with CLK; when the G inputs are low, the outputs are disabled to the logic-low state.

Unlike many products containing PLLs, the CDC509 does not require external RC networks. The loop filter for the PLL is included on-chip, minimizing component count, board space, and cost.

Because it is based on PLL circuitry, the CDC509 requires a stabilization time to achieve phase lock of the feedback signal to the reference signal. This stabilization time is required, following power up and application of a fixed-frequency, fixed-phase signal at CLK, as well as following any changes to the PLL reference or feedback signals. The PLL can be bypassed for test purposes by strapping AV_{CC} to ground.

The CDC509 is characterized for operation from 0°C to 70°C.

FUNCTION TABLE

INPUTS			OUTPUTS		
1G	2G	CLK	1Y (0:4)	2Y (0:3)	FBOUT
X	X	L	L	L	L
L	L	H	L	L	H
L	H	H	L	H	H
H	L	H	H	L	H
H	H	H	H	H	H



Please be aware that an important notice concerning availability, standard warranty, and use in critical applications of Texas Instruments semiconductor products and disclaimers thereto appears at the end of this data sheet.

PRODUCTION DATA information is current as of publication date. Products conform to specifications per the terms of Texas Instruments standard warranty. Production processing does not necessarily include testing of all parameters.

 **TEXAS
INSTRUMENTS**

POST OFFICE BOX 655303 • DALLAS, TEXAS 75265

Copyright © 1998, Texas Instruments Incorporated

CDC509

3.3-V PHASE-LOCK LOOP CLOCK DRIVER

SCAS576B – JULY 1996 – REVISED JANUARY 1998

functional block diagram

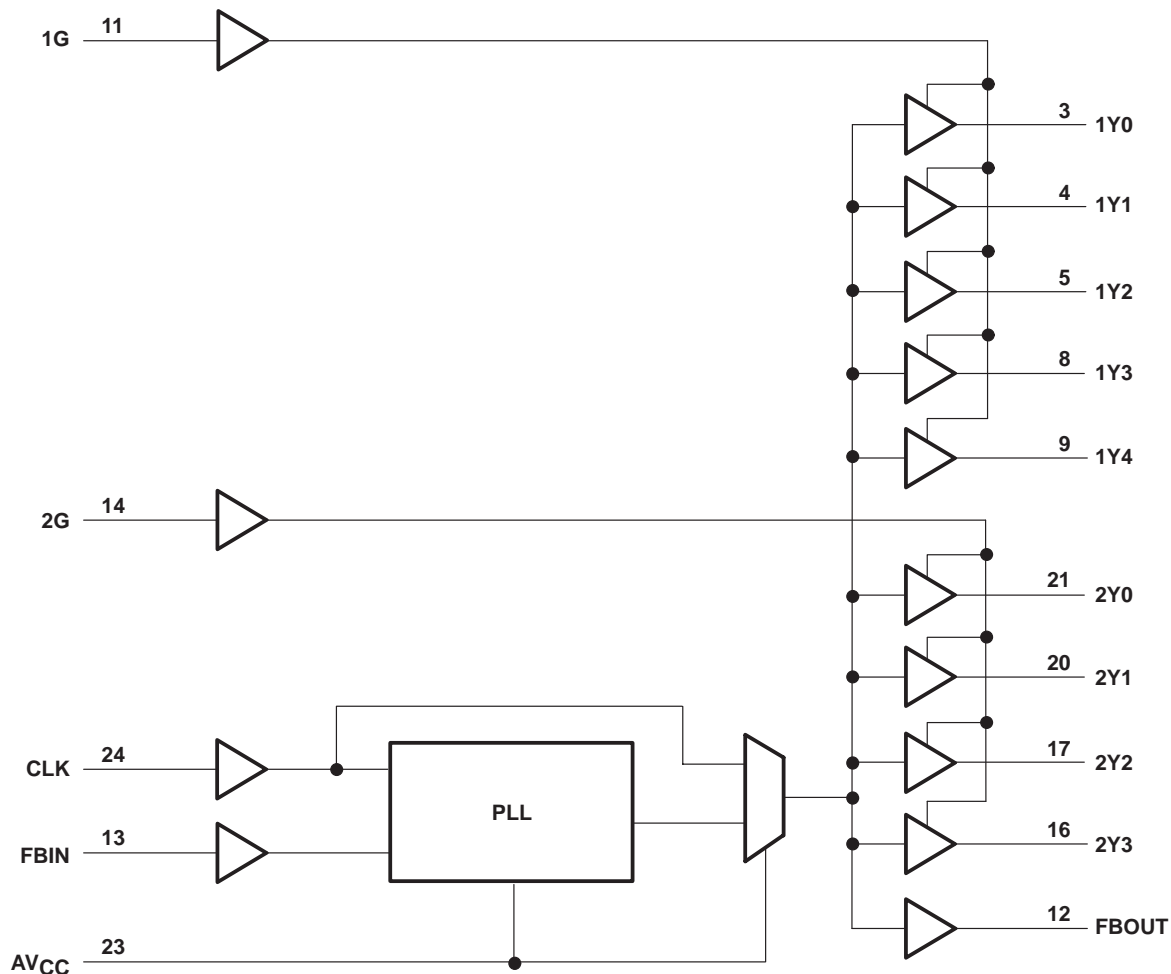

AVAILABLE OPTIONS

T _A	PACKAGE
	SMALL OUTLINE (PW)
0°C to 70°C	CDC509PWR



POST OFFICE BOX 655303 • DALLAS, TEXAS 75265

Terminal Functions

TERMINAL		TYPE	DESCRIPTION
NAME	NO.		
CLK	24	I	Clock input. CLK provides the clock signal to be distributed by the CDC509 clock driver. CLK is used to provide the reference signal to the integrated PLL that generates the clock output signals. CLK must have a fixed frequency and fixed phase for the PLL to obtain phase lock. Once the circuit is powered up and a valid CLK signal is applied, a stabilization time is required for the PLL to phase lock the feedback signal to its reference signal.
FBIN	13	I	Feedback input. FBIN provides the feedback signal to the internal PLL. FBIN must be hard-wired to FBOUT to complete the PLL. The integrated PLL synchronizes CLK and FBIN so that there is nominally zero phase error between CLK and FBIN.
1G	11	I	Output bank enable. 1G is the output enable for outputs 1Y(0:4). When 1G is low, outputs 1Y(0:4) are disabled to a logic-low state. When 1G is high, all outputs 1Y(0:4) are enabled and switch at the same frequency as CLK.
2G	14	I	Output bank enable. 2G is the output enable for outputs 2Y(0:3). When 2G is low, outputs 2Y(0:3) are disabled to a logic-low state. When 2G is high, all outputs 2Y(0:3) are enabled and switch at the same frequency as CLK.
FBOUT	12	O	Feedback output. FBOUT is dedicated for external feedback. It switches at the same frequency as CLK. When externally wired to FBIN, FBOUT completes the feedback loop of the PLL.
1Y(0:4)	3, 4, 5, 8, 9	O	Clock outputs. These outputs provide low-skew copies of CLK. Output bank 1Y(0:4) is enabled via the 1G input. These outputs can be disabled to a logic-low state by deasserting the 1G control input.
2Y(0:3)	16, 17, 20 21	O	Clock outputs. These outputs provide low-skew copies of CLK. Output bank 2Y(0:3) is enabled via the 2G input. These outputs can be disabled to a logic-low state by deasserting the 2G control input.
AV _{CC}	23	Power	Analog power supply. AV _{CC} provides the power reference for the analog circuitry. In addition, AV _{CC} can be used to bypass the PLL for test purposes. When AV _{CC} is strapped to ground, PLL is bypassed and CLK is buffered directly to the device outputs.
AGND	1	Ground	Analog ground. AGND provides the ground reference for the analog circuitry.
V _{CC}	2, 10, 15, 22	Power	Power supply
GND	6, 7, 18, 19	Ground	Ground

absolute maximum ratings over operating free-air temperature range (unless otherwise noted)†

Supply voltage range, V _{CC}	–0.5 V to 4.6 V
Input voltage range, V _I (see Note 1)	–0.5 V to 6.5 V
Voltage range applied to any output in the high or low state, V _O (see Notes 1 and 2)	–0.5 V to V _{CC} + 0.5 V
Input clamp current, I _{IK} (V _I < 0)	–50 mA
Output clamp current, I _{OK} (V _O < 0 or V _O > V _{CC})	±50 mA
Continuous output current, I _O (V _O = 0 to V _{CC})	±50 mA
Continuous current through each V _{CC} or GND	±100 mA
Maximum power dissipation at T _A = 55°C (in still air) (see Note 3)	0.7 W
Storage temperature range, T _{stg}	–65°C to 150°C

† Stresses beyond those listed under “absolute maximum ratings” may cause permanent damage to the device. These are stress ratings only, and functional operation of the device at these or any other conditions beyond those indicated under “recommended operating conditions” is not implied. Exposure to absolute-maximum-rated conditions for extended periods may affect device reliability.

- NOTES:
- The input and output negative-voltage ratings may be exceeded if the input and output clamp-current ratings are observed.
 - This value is limited to 4.6 V maximum.
 - The maximum package power dissipation is calculated using a junction temperature of 150°C and a board trace length of 750 mils. For more information, refer to the *Package Thermal Considerations* application note in the *ABT Advanced BiCMOS Technology Data Book*, literature number SCBD002.

CDC509

3.3-V PHASE-LOCK LOOP CLOCK DRIVER

SCAS576B – JULY 1996 – REVISED JANUARY 1998

recommended operating conditions (see Note 4)

	MIN	MAX	UNIT
V _{CC} Supply voltage	3	3.6	V
V _{IH} High-level input voltage	2		V
V _{IL} Low-level input voltage		0.8	V
V _I Input voltage	0	V _{CC}	V
I _{OH} High-level output current		-20	mA
I _{OL} Low-level output current		20	mA
T _A Operating free-air temperature	0	70	°C

NOTE 4: Unused inputs must be held high or low to prevent them from floating.

electrical characteristics over recommended operating free-air temperature range (unless otherwise noted)

PARAMETER	TEST CONDITIONS	V _{CC}	MIN	TYP†	MAX	UNIT
V _{IK}	I _I = -18 mA	3 V			-1.2	V
V _{OH}	I _{OH} = -100 μA	MIN to MAX	V _{CC} -0.2			V
	I _{OH} = -20 mA	3 V	2.4			
V _{OL}	I _{OL} = 100 μA	MIN to MAX			0.2	V
	I _{OL} = 20 mA	3 V			0.55	
I _I	V _I = V _{CC} or GND	3.6 V			±5	μA
I _{CC} ‡	V _I = V _{CC} or GND, I _O = 0, Output high or low	3.6 V			10	μA
ΔI _{CC}	One input at V _{CC} - 0.6 V, Other inputs at V _{CC} or GND	3.3 V to 3.6 V			500	μA
C _i	V _I = V _{CC} or GND	3.3 V			4	pF
C _o	V _O = V _{CC} or GND	3.3 V			6	pF

† For conditions shown as MIN or MAX, use the appropriate value specified under recommended operating conditions.

‡ For I_{CC} of AV_{CC}, see Figure 5.

timing requirements over recommended ranges of supply voltage and operating free-air temperature

	MIN	MAX	UNIT
f _{clock} Clock frequency	25	125	MHz
Input clock duty cycle	40%	60%	
Stabilization time§		1	ms

§ Time required for the integrated PLL circuit to obtain phase lock of its feedback signal to its reference signal. For phase lock to be obtained, a fixed-frequency, fixed-phase reference signal must be present at CLK. Until phase lock is obtained, the specifications for propagation delay, skew, and jitter parameters given in the switching characteristics table are not applicable.



switching characteristics over recommended ranges of supply voltage and operating free-air temperature, $C_L = 30$ pF (see Note 5 and Figures 1 and 2)[†]

PARAMETER	FROM (INPUT)	TO (OUTPUT)	$V_{CC} = 3.3$ V ± 0.165 V			$V_{CC} = 3.3$ V ± 0.3 V			UNIT
			MIN	TYP	MAX	MIN	TYP	MAX	
$t_{\text{phase error, reference}}$ (see Figure 3)	66 MHz < CLKIN \uparrow < 100 MHz	FBIN \uparrow					100...480		ps
$t_{\text{phase error, - jitter}}$, (see Note 6)	CLKIN $\uparrow = 100$ MHz	FBIN \uparrow	220		480		340		ps
$t_{\text{sk(o)}}^{\ddagger}$	Any Y or FBOU \uparrow	Any Y or FBOU \uparrow						200	ps
Jitter (pk-pk)	F(clkin > 66 MHz)	Any Y or FBOU \uparrow				-100		100	ps
Duty cycle, reference (see Figure 4)	F(clkin \leq 66 MHz)	Any Y or FBOU \uparrow				45%		55%	
	F(clkin > 66 MHz)	Any Y or FBOU \uparrow				43%		57%	
t_r		Any Y or FBOU \uparrow		1.1	1.5	0.7		1.6	ns
t_f		Any Y or FBOU \uparrow		0.8	1.3	0.5		1.5	ns

[†] This parameters are not production tested.

[‡] The $t_{\text{sk(o)}}$ specification is only valid for equal loading of all outputs.

NOTES: 5. The specifications for parameters in this table are applicable only after any appropriate stabilization time has elapsed.

6. Phase error does not include jitter. The total phase error is 120 ps to 580 ps for the 5% V_{CC} range.

PARAMETER MEASUREMENT INFORMATION

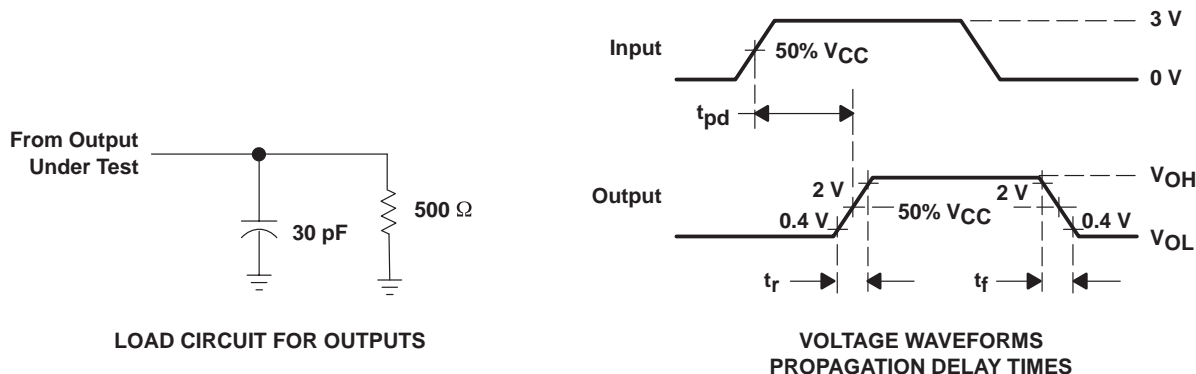

NOTES: A. C_L includes probe and jig capacitance.

B. All input pulses are supplied by generators having the following characteristics: PRR \leq 100 MHz, $Z_O = 50$ Ω , $t_r \leq 1.2$ ns, $t_f \leq 1.2$ ns.

C. The outputs are measured one at a time with one transition per measurement.

Figure 1. Load Circuit and Voltage Waveforms

CDC509

3.3-V PHASE-LOCK LOOP CLOCK DRIVER

SCAS576B – JULY 1996 – REVISED JANUARY 1998

PARAMETER MEASUREMENT INFORMATION

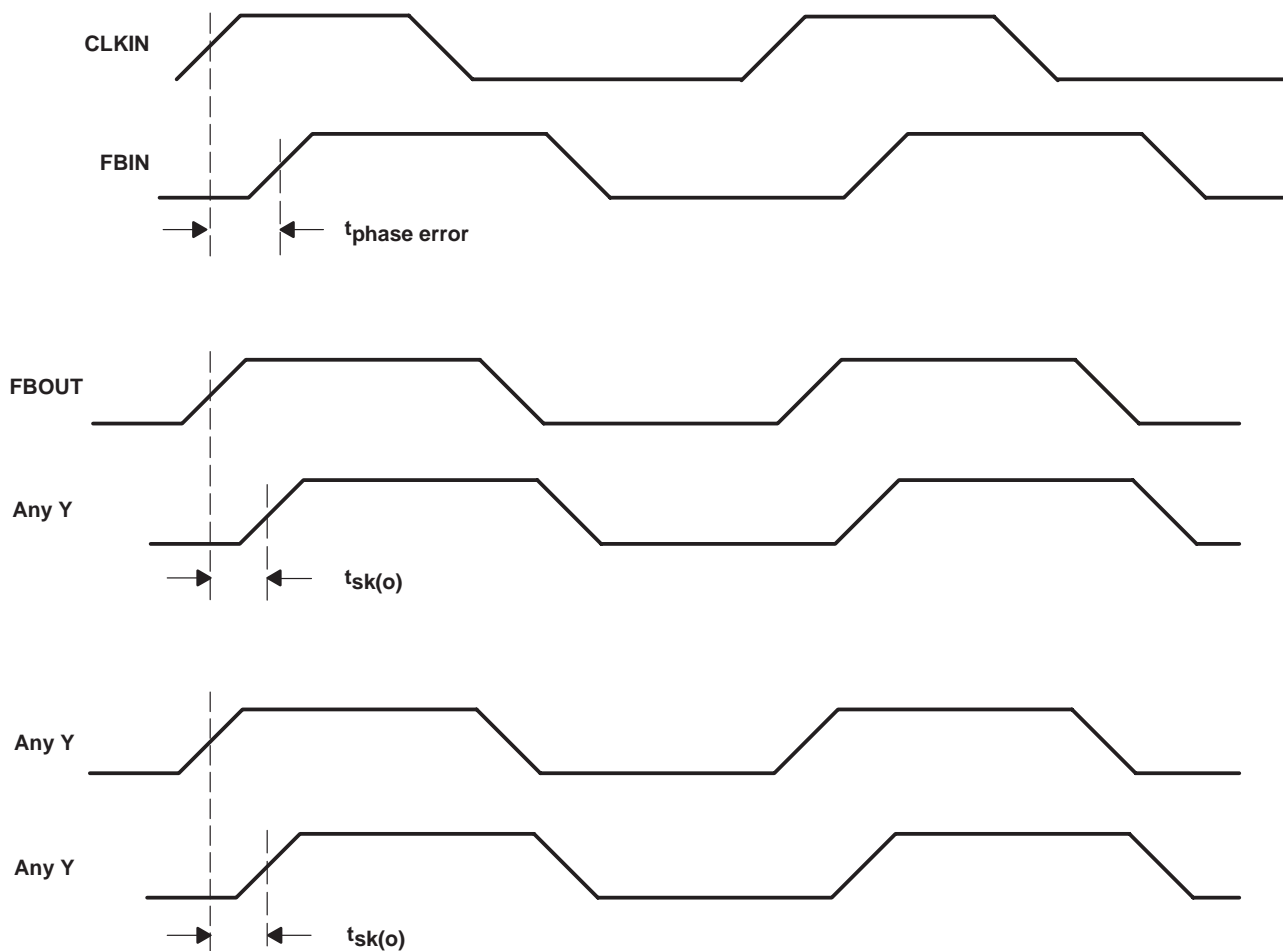

Figure 2. Phase Error and Skew Calculations



TYPICAL CHARACTERISTICS

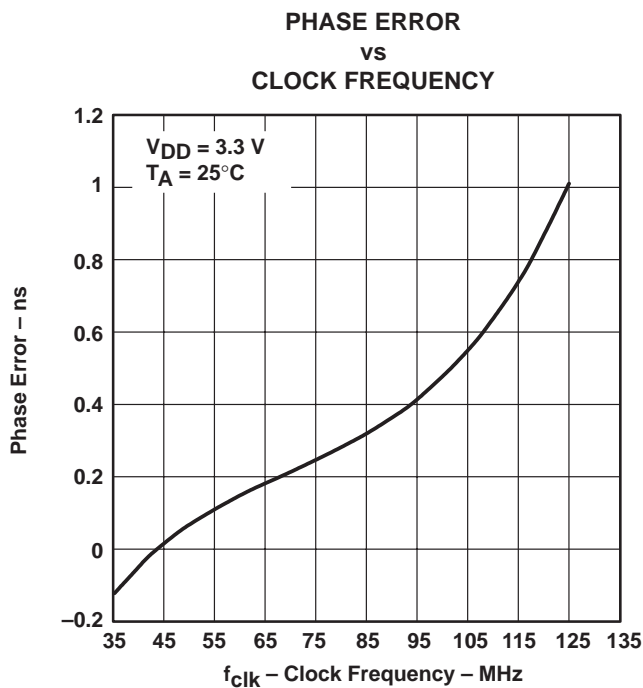

Figure 3

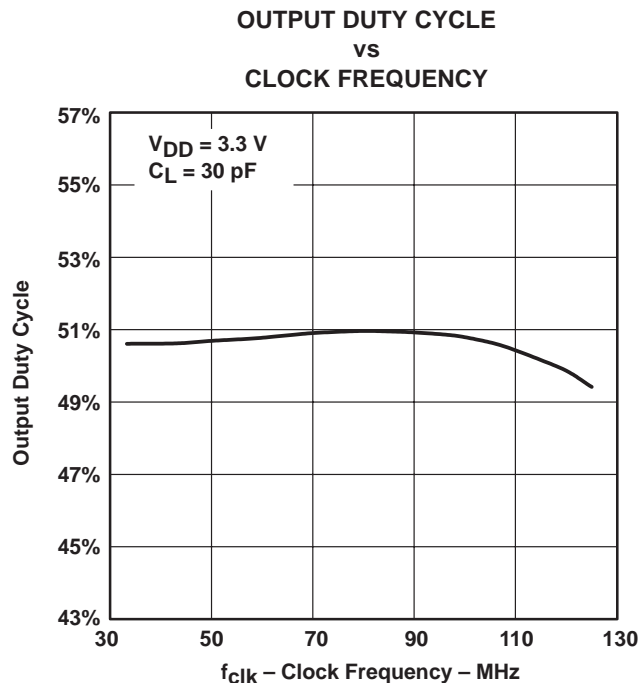

Figure 4

**ANALOG SUPPLY CURRENT
vs
CLOCK FREQUENCY**

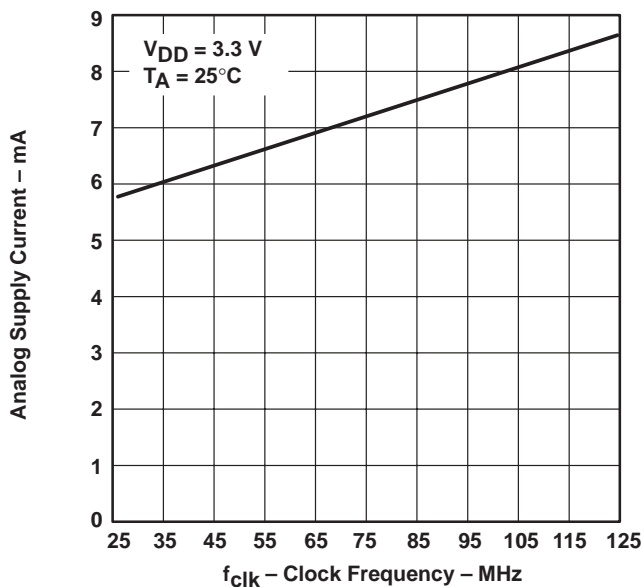

Figure 5

CDC509

3.3-V PHASE-LOCK LOOP CLOCK DRIVER

SCAS576B – JULY 1996 – REVISED JANUARY 1998

MECHANICAL INFORMATION

PW (R-PDSO-G**)

PLASTIC SMALL-OUTLINE PACKAGE

14 PIN SHOWN

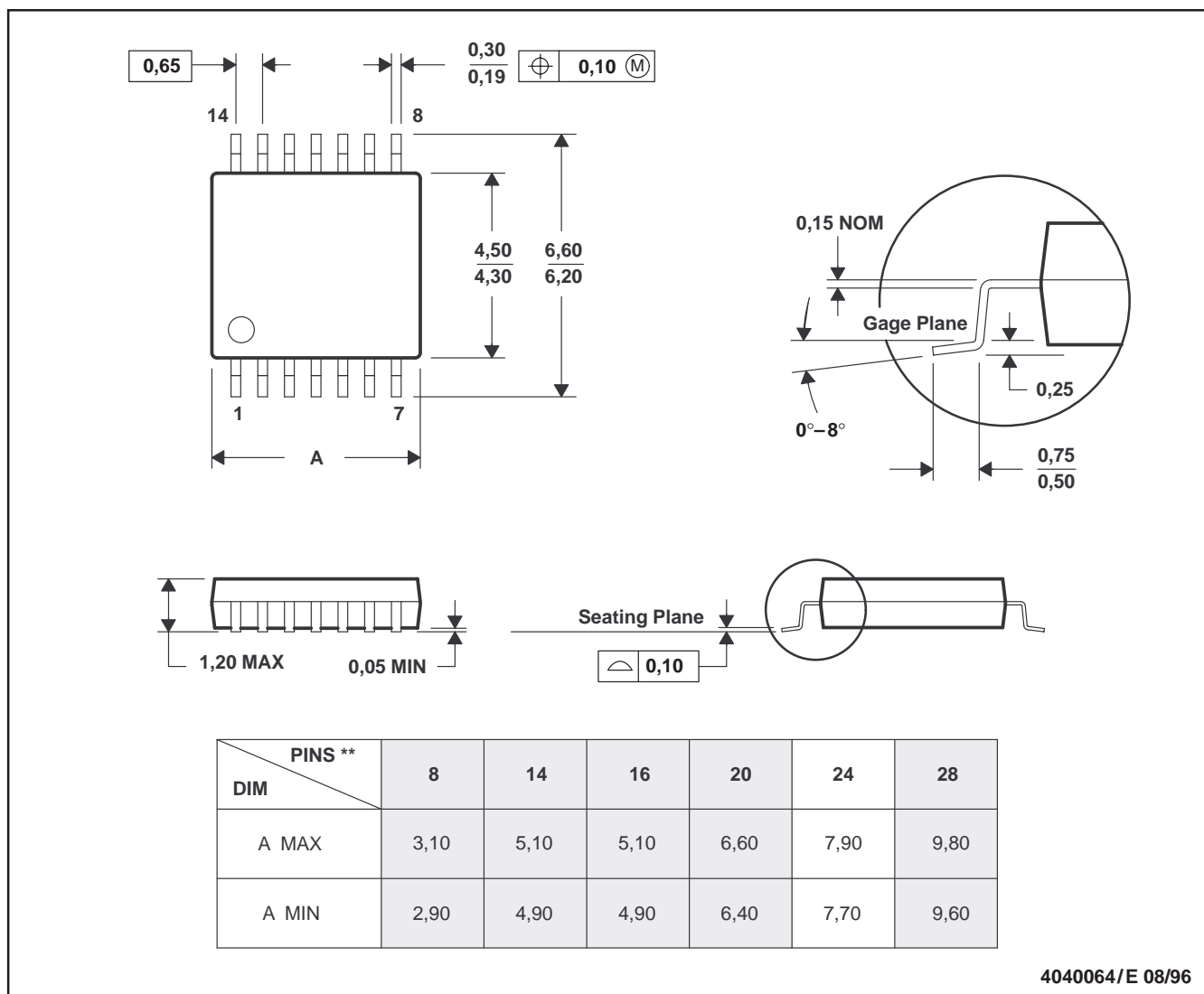

4040064/E 08/96

- NOTES:
- A. All linear dimensions are in millimeters.
 - B. This drawing is subject to change without notice.
 - C. Body dimensions do not include mold flash or protrusion not to exceed 0,15.
 - D. Falls within JEDEC MO-153

IMPORTANT NOTICE

Texas Instruments (TI) reserves the right to make changes to its products or to discontinue any semiconductor product or service without notice, and advises its customers to obtain the latest version of relevant information to verify, before placing orders, that the information being relied on is current.

TI warrants performance of its semiconductor products and related software to the specifications applicable at the time of sale in accordance with TI's standard warranty. Testing and other quality control techniques are utilized to the extent TI deems necessary to support this warranty. Specific testing of all parameters of each device is not necessarily performed, except those mandated by government requirements.

Certain applications using semiconductor products may involve potential risks of death, personal injury, or severe property or environmental damage ("Critical Applications").

TI SEMICONDUCTOR PRODUCTS ARE NOT DESIGNED, INTENDED, AUTHORIZED, OR WARRANTED TO BE SUITABLE FOR USE IN LIFE-SUPPORT APPLICATIONS, DEVICES OR SYSTEMS OR OTHER CRITICAL APPLICATIONS.

Inclusion of TI products in such applications is understood to be fully at the risk of the customer. Use of TI products in such applications requires the written approval of an appropriate TI officer. Questions concerning potential risk applications should be directed to TI through a local SC sales office.

In order to minimize risks associated with the customer's applications, adequate design and operating safeguards should be provided by the customer to minimize inherent or procedural hazards.

TI assumes no liability for applications assistance, customer product design, software performance, or infringement of patents or services described herein. Nor does TI warrant or represent that any license, either express or implied, is granted under any patent right, copyright, mask work right, or other intellectual property right of TI covering or relating to any combination, machine, or process in which such semiconductor products or services might be or are used.