

- Spread Spectrum Clock Compatible
- 100 MHz Maximum Frequency
- Available in Plastic 24-Pin TSSOP
- Phase-Lock Loop Clock Distribution for Synchronous DRAM Applications
- Distributes One Clock Input to One Bank of Ten Outputs
- Single Output Enable Terminal Controls All Ten Outputs
- External Feedback (FBIN) Pin Is Used to Synchronize the Outputs to the Clock Input
- On-Chip Series Damping Resistors
- No External RC Network Required
- Operates at 3.3-V  $V_{CC}$

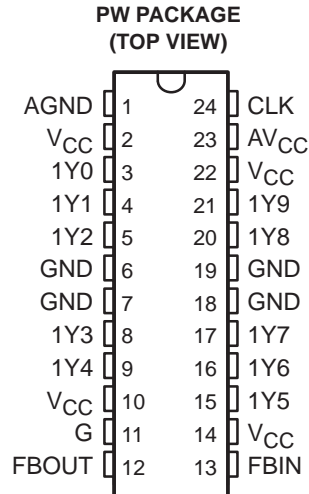

### description

The CDC2510A is a high-performance, low-skew, low-jitter, phase-lock loop (PLL) clock driver. It uses a PLL to precisely align, in both frequency and phase, the feedback (FBOUT) output to the clock (CLK) input signal. It is specifically designed for use with synchronous DRAMs. The CDC2510A operates at 3.3-V  $V_{CC}$  and provides integrated series-damping resistors that make it ideal for driving point-to-point loads.

One bank of ten outputs provides ten low-skew, low-jitter copies of CLK. Output signal duty cycles are adjusted to 50 percent, independent of the duty cycle at CLK. All outputs can be enabled or disabled via a single output enable input. When the G input is high, the outputs switch in phase and frequency with CLK; when the G input is low, the outputs are disabled to the logic-low state.

Unlike many products containing PLLs, the CDC2510A does not require external RC networks. The loop filter for the PLL is included on-chip, minimizing component count, board space, and cost.

Because it is based on PLL circuitry, the CDC2510A requires a stabilization time to achieve phase lock of the feedback signal to the reference signal. This stabilization time is required, following power up and application of a fixed-frequency, fixed-phase signal at CLK, and following any changes to the PLL reference or feedback signals. The PLL can be bypassed for test purposes by strapping  $AV_{CC}$  to ground.

The CDC2510A is characterized for operation from 0°C to 70°C.

**FUNCTION TABLE**

INPUTS		OUTPUTS	
G	CLK	1Y (0:9)	FBOUT
X	L	L	L
L	H	L	H
H	H	H	H



Please be aware that an important notice concerning availability, standard warranty, and use in critical applications of Texas Instruments semiconductor products and disclaimers thereto appears at the end of this data sheet.

# CDC2510A 3.3-V PHASE-LOCK LOOP CLOCK DRIVER

SCAS604A—APRIL 1998 — REVISED JUNE 1998

## functional block diagram

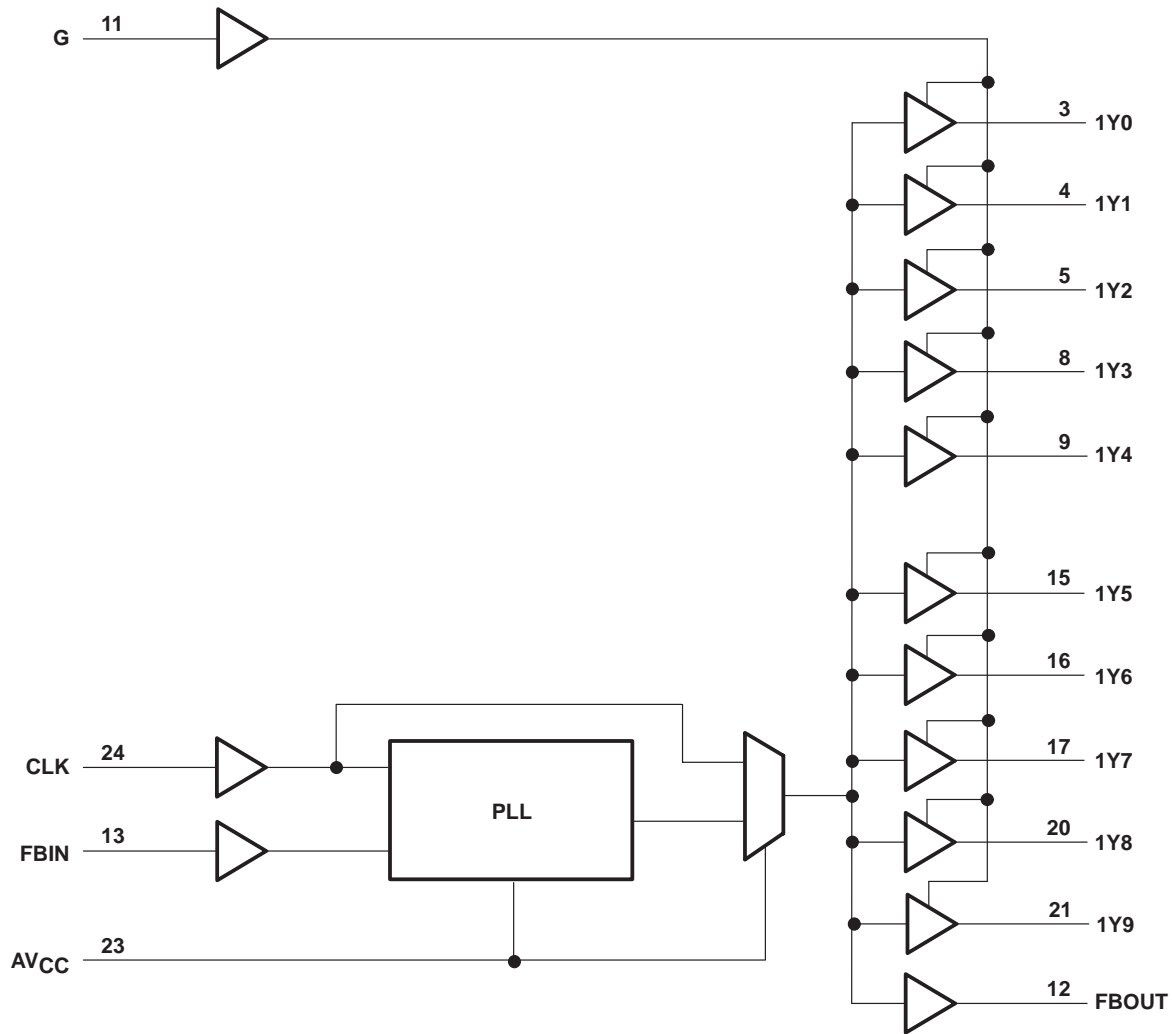

### AVAILABLE OPTIONS

T <sub>A</sub>	PACKAGE
	SMALL OUTLINE (PW)
0°C to 70°C	CDC2510A

# CDC2510A

## 3.3-V PHASE-LOCK LOOP CLOCK DRIVER

SCAS604A– APRIL 1998 – REVISED JUNE 1998

### Terminal Functions

TERMINAL		TYPE	DESCRIPTION
NAME	NO.		
CLK	24	I	Clock input. CLK provides the clock signal to be distributed by the CDC2510A clock driver. CLK is used to provide the reference signal to the integrated PLL that generates the clock output signals. CLK must have a fixed frequency and fixed phase for the PLL to obtain phase lock. Once the circuit is powered up and a valid CLK signal is applied, a stabilization time is required for the PLL to phase lock the feedback signal to its reference signal.
FBIN	13	I	Feedback input. FBIN provides the feedback signal to the internal PLL. FBIN must be hard-wired to FBOUT to complete the PLL. The integrated PLL synchronizes CLK and FBIN so that there is nominally zero phase error between CLK and FBIN.
G	11	I	Output bank enable. G is the output enable for outputs 1Y(0:9). When G is low, outputs 1Y(0:9) are disabled to a logic-low state. When G is high, all outputs 1Y(0:9) are enabled and switch at the same frequency as CLK.
FBOUR	12	O	Feedback output. FBOUR is dedicated for external feedback. It switches at the same frequency as CLK. When externally wired to FBIN, FBOUR completes the feedback loop of the PLL. FBOUR has an integrated 25-Ω series-damping resistor.
1Y (0:9)	3, 4, 5, 8, 9 15, 16, 17, 20, 21	O	Clock outputs. These outputs provide low-skew copies of CLK. Output bank 1Y(0:9) is enabled via the G input. These outputs can be disabled to a logic-low state by deasserting the G control input. Each output has an integrated 25-Ω series-damping resistor.
AVCC	23	Power	Analog power supply. AVCC provides the power reference for the analog circuitry. In addition, AVCC can be used to bypass the PLL for test purposes. When AVCC is strapped to ground, PLL is bypassed and CLK is buffered directly to the device outputs.
AGND	1	Ground	Analog ground. AGND provides the ground reference for the analog circuitry.
VCC	2, 10, 14, 22	Power	Power supply
GND	6, 7, 18, 19	Ground	Ground



# CDC2510A

## 3.3-V PHASE-LOCK LOOP CLOCK DRIVER

SCAS604A—APRIL 1998—REVISED JUNE 1998

### absolute maximum ratings over operating free-air temperature range (unless otherwise noted)†

Supply voltage, $AV_{CC}$ (see Note 1)	$AV_{CC} < V_{CC} + 0.7$ V
Supply voltage range, $V_{CC}$ , $AV_{CC}$	-0.5 V to 4.6 V
Input voltage range, $V_I$ (see Note 2)	-0.5 V to 6.5 V
Voltage range applied to any output in the high or low state, $V_O$ (see Notes 2 and 3)	-0.5 V to $V_{CC} + 0.5$ V
Input clamp current, $I_{IK}$ ( $V_I < 0$ )	-50 mA
Output clamp current, $I_{OK}$ ( $V_O < 0$ or $V_O > V_{CC}$ )	$\pm 50$ mA
Continuous output current, $I_O$ ( $V_O = 0$ to $V_{CC}$ )	$\pm 50$ mA
Continuous current through each $V_{CC}$ or GND	$\pm 100$ mA
Maximum power dissipation at $T_A = 55^\circ\text{C}$ (in still air) (see Note 4)	0.7 W
Storage temperature range, $T_{stg}$	$-65^\circ\text{C}$ to $150^\circ\text{C}$

† Stresses beyond those listed under “absolute maximum ratings” may cause permanent damage to the device. These are stress ratings only, and functional operation of the device at these or any other conditions beyond those indicated under “recommended operating conditions” is not implied. Exposure to absolute-maximum-rated conditions for extended periods may affect device reliability.

- NOTES:
- $AV_{CC}$  **must not** exceed  $V_{CC}$ .
  - The input and output negative-voltage ratings may be exceeded if the input and output clamp-current ratings are observed.
  - This value is limited to 4.6 V maximum.
  - The maximum package power dissipation is calculated using a junction temperature of  $150^\circ\text{C}$  and a board trace length of 750 mils. For more information, refer to the *Package Thermal Considerations* application note in the *ABT Advanced BiCMOS Technology Data Book*, literature number SCBD002.

### recommended operating conditions (see Note 5)

	MIN	MAX	UNIT
$V_{CC}$ , $AV_{CC}$ Supply voltage	3	3.6	V
$V_{IH}$ High-level input voltage	2		V
$V_{IL}$ Low-level input voltage		0.8	V
$V_I$ Input voltage	0	$V_{CC}$	V
$I_{OH}$ High-level output current		-12	mA
$I_{OL}$ Low-level output current		12	mA
$T_A$ Operating free-air temperature	0	70	$^\circ\text{C}$

NOTE 5: Unused inputs must be held high or low to prevent them from floating.



**electrical characteristics over recommended operating free-air temperature range (unless otherwise noted)**

PARAMETER	TEST CONDITIONS	AV <sub>CC</sub> , V <sub>CC</sub>	MIN	TYP <sup>‡</sup>	MAX	UNIT
V <sub>IK</sub>	I <sub>I</sub> = –18 mA	3 V			–1.2	V
V <sub>OH</sub>	I <sub>OH</sub> = –100 μA	MIN to MAX	V <sub>CC</sub> – 0.2			V
	I <sub>OH</sub> = –12 mA	3 V	2.1			
	I <sub>OH</sub> = –6 mA	3 V	2.4			
V <sub>OL</sub>	I <sub>OL</sub> = 100 μA	MIN to MAX	0.2			V
	I <sub>OL</sub> = 12 mA	3 V	0.8			
	I <sub>OL</sub> = 6 mA	3 V	0.55			
I <sub>I</sub>	V <sub>I</sub> = V <sub>CC</sub> or GND	3.6 V	±5			μA
I <sub>CC</sub> <sup>§</sup>	V <sub>I</sub> = V <sub>CC</sub> or GND, I <sub>O</sub> = 0, Outputs: low or high	3.6 V	10			μA
ΔI <sub>CC</sub>	One input at V <sub>CC</sub> – 0.6 V, Other inputs at V <sub>CC</sub> or GND	3.3 V to 3.6 V	500			μA
C <sub>i</sub>	V <sub>I</sub> = V <sub>CC</sub> or GND	3.3 V	4			pF
C <sub>o</sub>	V <sub>O</sub> = V <sub>CC</sub> or GND	3.3 V	6			pF

<sup>‡</sup> For conditions shown as MIN or MAX, use the appropriate value specified under recommended operating conditions.

<sup>§</sup> For I<sub>CC</sub> of AV<sub>CC</sub>, see Figure 5.

**timing requirements over recommended ranges of supply voltage and operating free-air temperature**

	MIN	MAX	UNIT
f <sub>clk</sub> Clock frequency	80	100	MHz
Input clock duty cycle	40%	60%	
Stabilization time <sup>†</sup>		1	ms

<sup>†</sup> Time required for the integrated PLL circuit to obtain phase lock of its feedback signal to its reference signal. For phase lock to be obtained, a fixed-frequency, fixed-phase reference signal must be present at CLK. Until phase lock is obtained, the specifications for propagation delay, skew, and jitter parameters given in the switching characteristics table are not applicable. This parameter does not apply for input modulation under SSC application.

**switching characteristics over recommended ranges of supply voltage and operating free-air temperature, C<sub>L</sub> = 30 pF (see Note 6 and Figures 1 and 2)<sup>‡</sup>**

PARAMETER	FROM (INPUT)/CONDITION	TO (OUTPUT)	V <sub>CC</sub> , AV <sub>CC</sub> = 3.3 V ± 0.165 V			V <sub>CC</sub> , AV <sub>CC</sub> = 3.3 V ± 0.3 V			UNIT
			MIN	TYP	MAX	MIN	TYP	MAX	
t <sub>phase error</sub> , reference (see Note 7, Figure 3)	80 MHz < CLKIN <sup>↑</sup> ≤ 100 MHz	FBIN <sup>↑</sup>				–700		–300	ps
t <sub>phase error</sub> , jitter (see Note 8)	CLKIN <sup>↑</sup> = 100 MHz	FBIN <sup>↑</sup>	–750		–350	–540			ps
t <sub>sk(o)</sub> <sup>§</sup>	Any Y or FBOUT	Any Y or FBOUT						200	ps
Jitter <sub>(pk-pk)</sub> (see Figure 4)	Clkin = 100 MHz	Any Y or FBOUT				–150		150	ps
Duty cycle reference (see Figure 4)	F(clkin > 80 MHz)	Any Y or FBOUT				45%		55%	
t <sub>r</sub>		Any Y or FBOUT		1.3	1.9	0.8		2.1	ns
t <sub>f</sub>		Any Y or FBOUT		1.7	2.5	1.2		2.7	ns

<sup>‡</sup> These parameters are not production tested.

<sup>§</sup> The t<sub>sk(o)</sub> specification is only valid for equal loading of all outputs.

- NOTES:
6. The specifications for parameters in this table are applicable only after any appropriate stabilization time has elapsed.
  7. This is considered as static phase error.
  8. Phase error does not include jitter. The total phase error is –900 ps to –200 ps for the 5% V<sub>CC</sub> range.

# CDC2510A

## 3.3-V PHASE-LOCK LOOP CLOCK DRIVER

SCAS604A—APRIL 1998—REVISED JUNE 1998

### PARAMETER MEASUREMENT INFORMATION

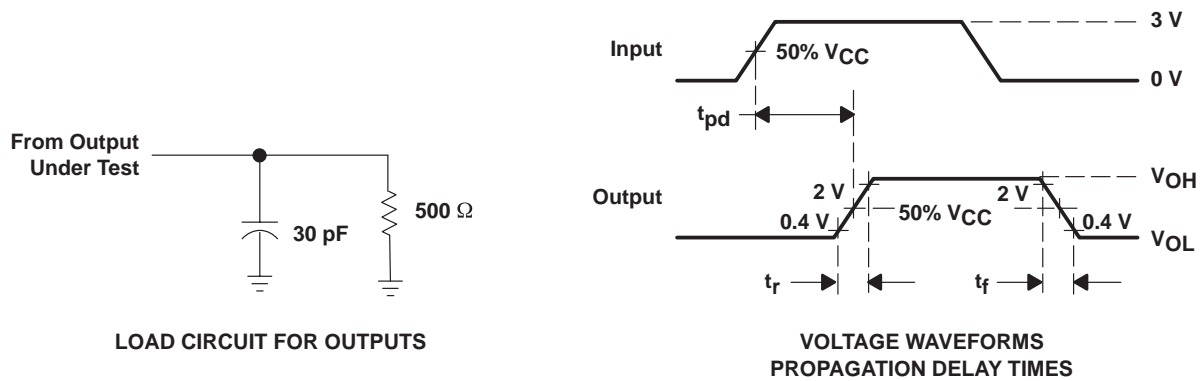

- NOTES: A.  $C_L$  includes probe and jig capacitance.  
 B. All input pulses are supplied by generators having the following characteristics:  $PRR \leq 100$  MHz,  $Z_O = 50 \Omega$ ,  $t_r \leq 1.2$  ns,  $t_f \leq 1.2$  ns.  
 C. The outputs are measured one at a time with one transition per measurement.

Figure 1. Load Circuit and Voltage Waveforms

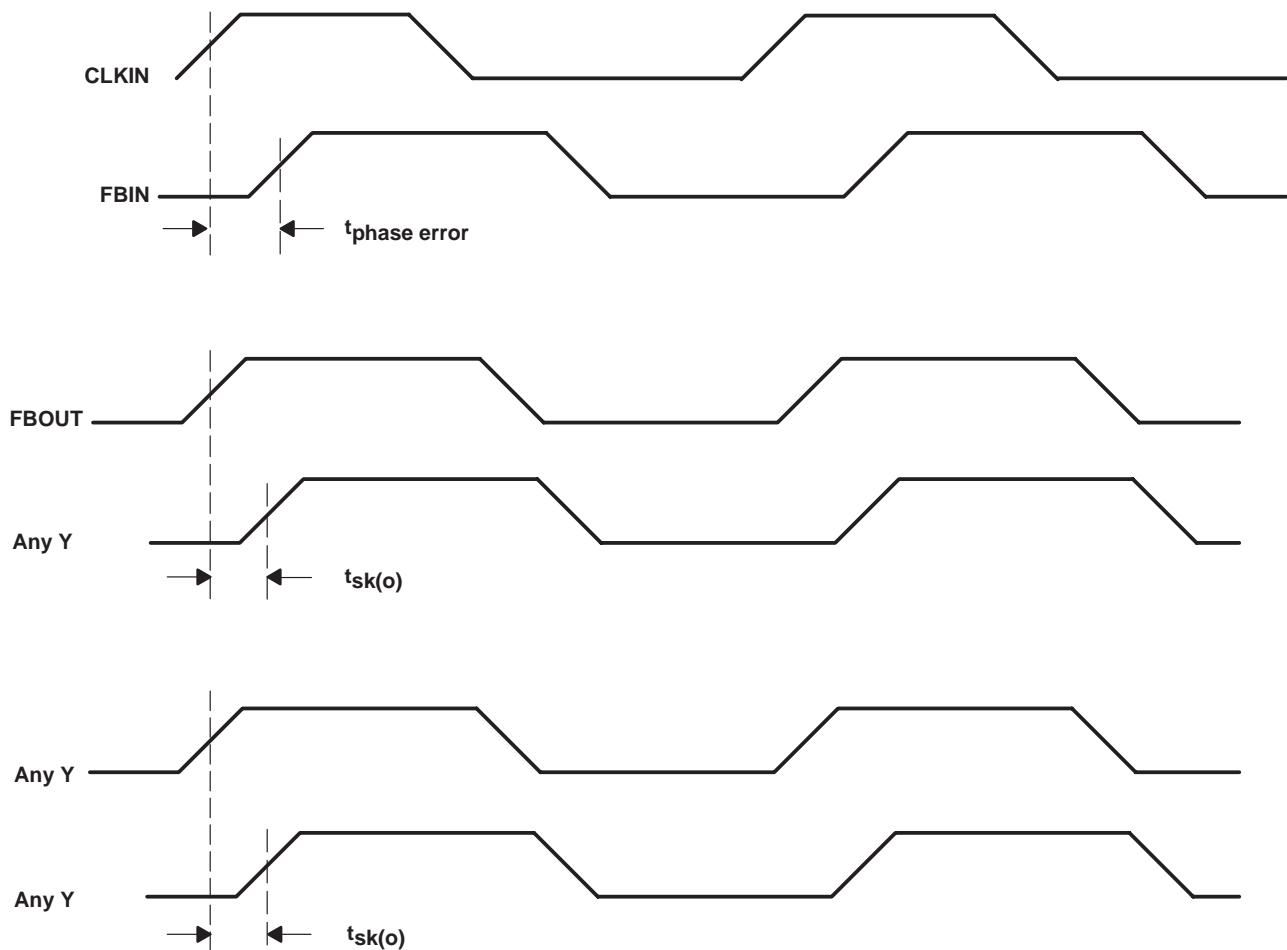

Figure 2. Phase Error and Skew Calculations

TYPICAL CHARACTERISTICS

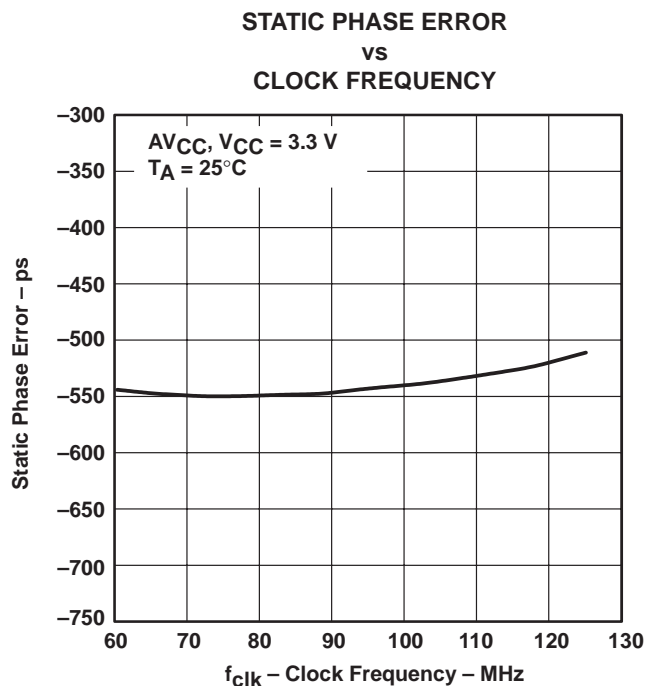

Figure 3

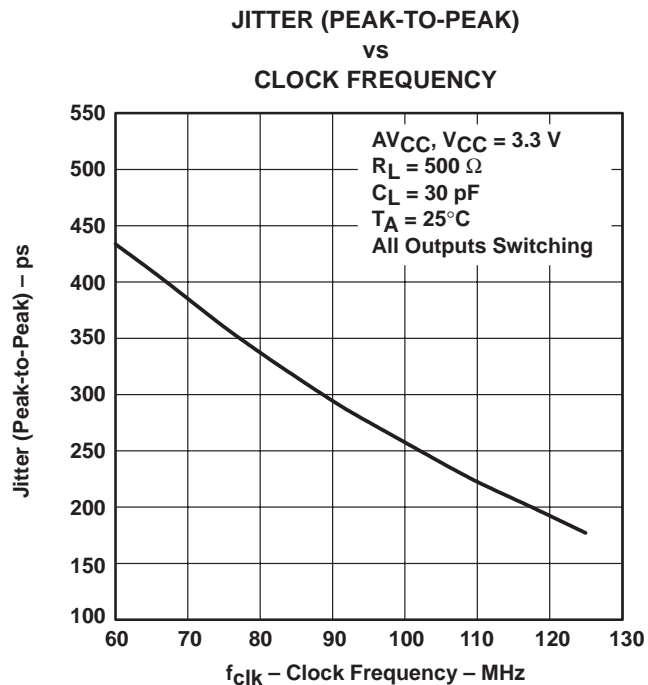

Figure 4

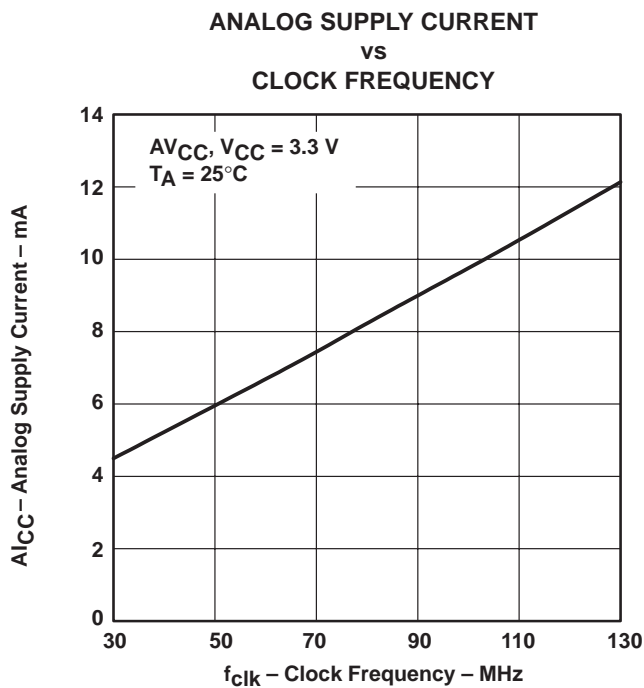

Figure 5

# CDC2510A

## 3.3-V PHASE-LOCK LOOP CLOCK DRIVER

SCAS604A—APRIL 1998—REVISED JUNE 1998

### MECHANICAL INFORMATION

PW (R-PDSO-G\*\*)

PLASTIC SMALL-OUTLINE PACKAGE

14 PIN SHOWN

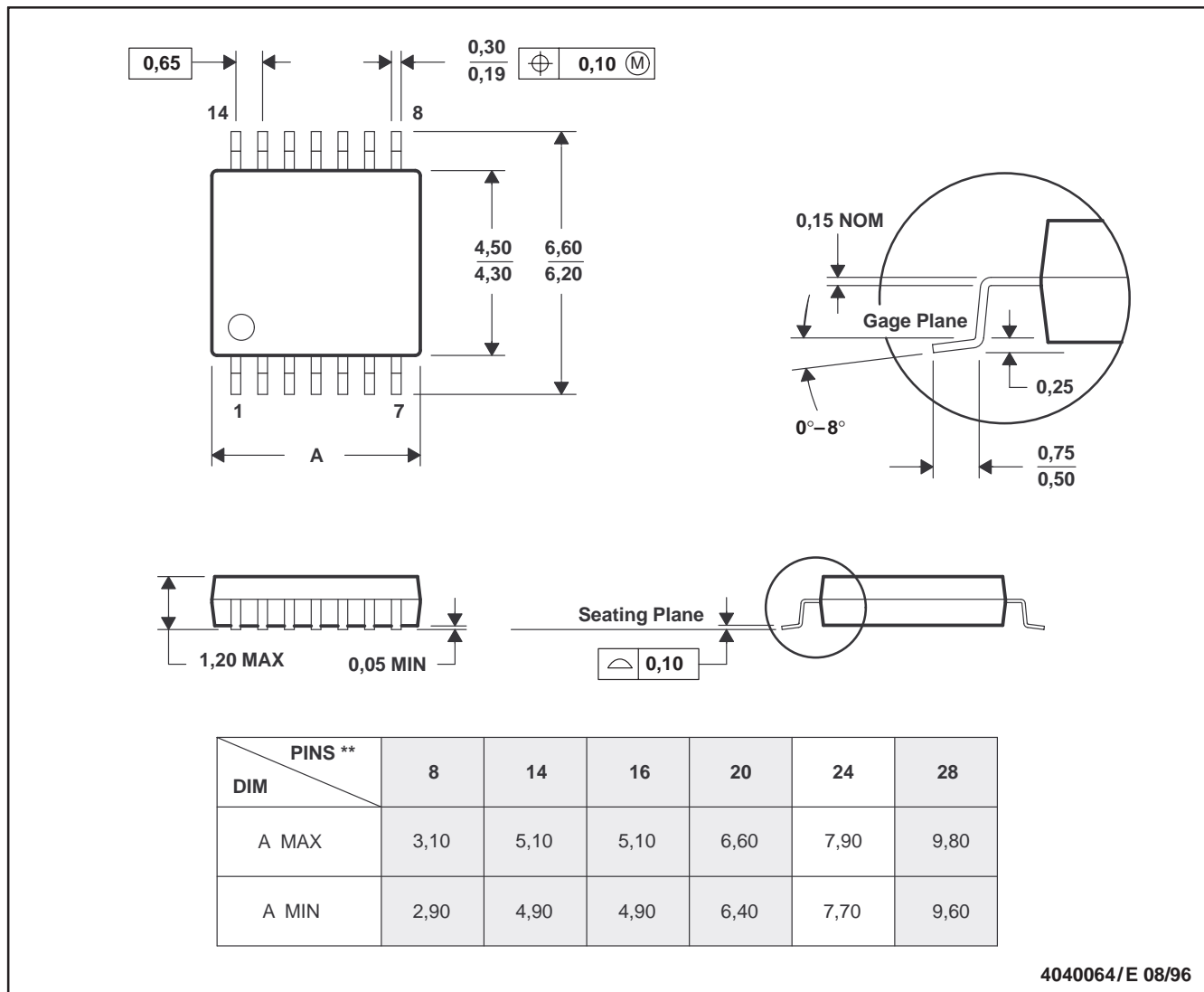

4040064/E 08/96

- NOTES: D. All linear dimensions are in millimeters.  
 E. This drawing is subject to change without notice.  
 F. Body dimensions do not include mold flash or protrusion not to exceed 0,15.  
 G. Falls within JEDEC MO-153



## **IMPORTANT NOTICE**

Texas Instruments and its subsidiaries (TI) reserve the right to make changes to their products or to discontinue any product or service without notice, and advise customers to obtain the latest version of relevant information to verify, before placing orders, that information being relied on is current and complete. All products are sold subject to the terms and conditions of sale supplied at the time of order acknowledgement, including those pertaining to warranty, patent infringement, and limitation of liability.

TI warrants performance of its semiconductor products to the specifications applicable at the time of sale in accordance with TI's standard warranty. Testing and other quality control techniques are utilized to the extent TI deems necessary to support this warranty. Specific testing of all parameters of each device is not necessarily performed, except those mandated by government requirements.

**CERTAIN APPLICATIONS USING SEMICONDUCTOR PRODUCTS MAY INVOLVE POTENTIAL RISKS OF DEATH, PERSONAL INJURY, OR SEVERE PROPERTY OR ENVIRONMENTAL DAMAGE ("CRITICAL APPLICATIONS"). TI SEMICONDUCTOR PRODUCTS ARE NOT DESIGNED, AUTHORIZED, OR WARRANTED TO BE SUITABLE FOR USE IN LIFE-SUPPORT DEVICES OR SYSTEMS OR OTHER CRITICAL APPLICATIONS. INCLUSION OF TI PRODUCTS IN SUCH APPLICATIONS IS UNDERSTOOD TO BE FULLY AT THE CUSTOMER'S RISK.**

In order to minimize risks associated with the customer's applications, adequate design and operating safeguards must be provided by the customer to minimize inherent or procedural hazards.

TI assumes no liability for applications assistance or customer product design. TI does not warrant or represent that any license, either express or implied, is granted under any patent right, copyright, mask work right, or other intellectual property right of TI covering or relating to any combination, machine, or process in which such semiconductor products or services might be or are used. TI's publication of information regarding any third party's products or services does not constitute TI's approval, warranty or endorsement thereof.