

SN55LBC174 QUADRUPLE LOW-POWER DIFFERENTIAL LINE DRIVER

SGLS082 – MARCH 1995

- Meets EIA Standard RS-485
- Designed for High-Speed Multipoint Transmission on Long Bus Lines in Noisy Environments
- Supports Data Rates up to and Exceeding Ten Million Transfers Per Second
- Common-Mode Output Voltage Range of -7 V to 12 V
- Positive- and Negative-Current Limiting
- Low Power Consumption . . . 1.5 mA Max (Output Disabled)

description

The SN55LBC174 is composed of monolithic quadruple differential line drivers with 3-state outputs. This device is designed to meet the requirements of the Electronics Industry Association (EIA) Standard RS-485 and is optimized for balanced multipoint bus transmission at data rates up to and exceeding 10 million bits per second. Each driver features wide positive and negative common-mode output voltage ranges, current limiting, and thermal-shutdown protection making it suitable for party-line applications in noisy environments. This device is designed using LinBiCMOS™, facilitating ultra-low power consumption and inherent robustness.

The SN55LBC174 provides positive and negative-current limiting and thermal shutdown for protection from line fault conditions on the transmission bus line. This device offers optimum performance when used with the SN55LBC173 quadruple line receiver. The SN55LBC174 is available in the 16-pin CDIP package (J), the 16-pin CPAK (W), or the 20-pin LCCC package (FK).

The SN55LBC174 is characterized for operation over the military temperature range of -55°C to 125°C .

J OR W PACKAGE
(TOP VIEW)

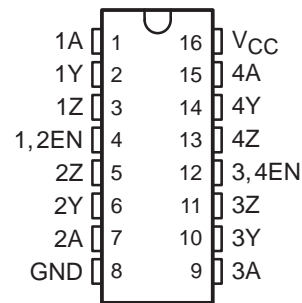

FK PACKAGE
(TOP VIEW)

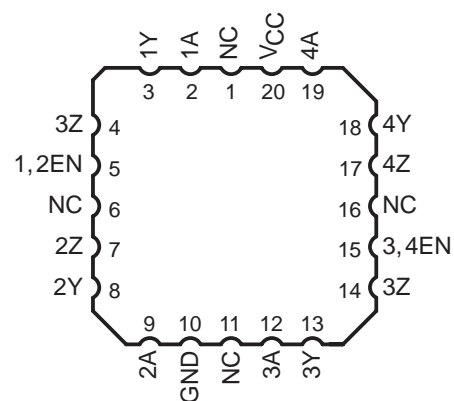

NC – No internal connection

FUNCTION TABLE
(each driver)

| INPUT | ENABLE | OUTPUTS | |
|-------|--------|---------|---|
| | | Y | Z |
| H | H | H | L |
| L | H | L | H |
| X | L | Z | Z |

H = high level, L = low level, X = irrelevant,
Z = high impedance (off)



Please be aware that an important notice concerning availability, standard warranty, and use in critical applications of Texas Instruments semiconductor products and disclaimers thereto appears at the end of this data sheet.

LinBiCMOS is a trademark of Texas Instruments Incorporated.

PRODUCTION DATA information is current as of publication date. Products conform to specifications per the terms of Texas Instruments standard warranty. Production processing does not necessarily include testing of all parameters.

 **TEXAS
INSTRUMENTS**

POST OFFICE BOX 655303 • DALLAS, TEXAS 75265

Copyright © 1995, Texas Instruments Incorporated

SN55LBC174 QUADRUPLE LOW-POWER DIFFERENTIAL LINE DRIVER

SGLS082 – MARCH 1995

logic symbol†

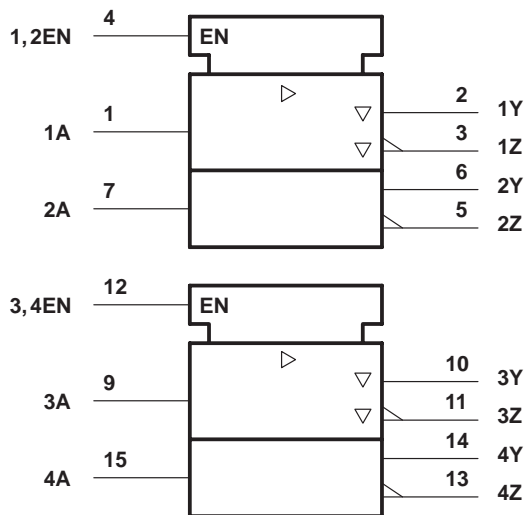

logic diagram (positive logic)

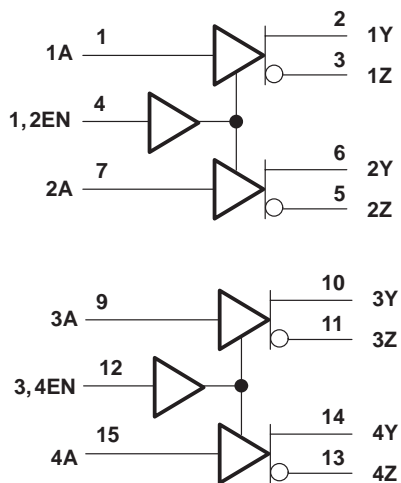

† This symbol is in accordance with ANSI/IEEE Std 91-1984 and IEC Publication 617-12. Pin numbers shown are for the J or W package.

schematic of inputs and outputs

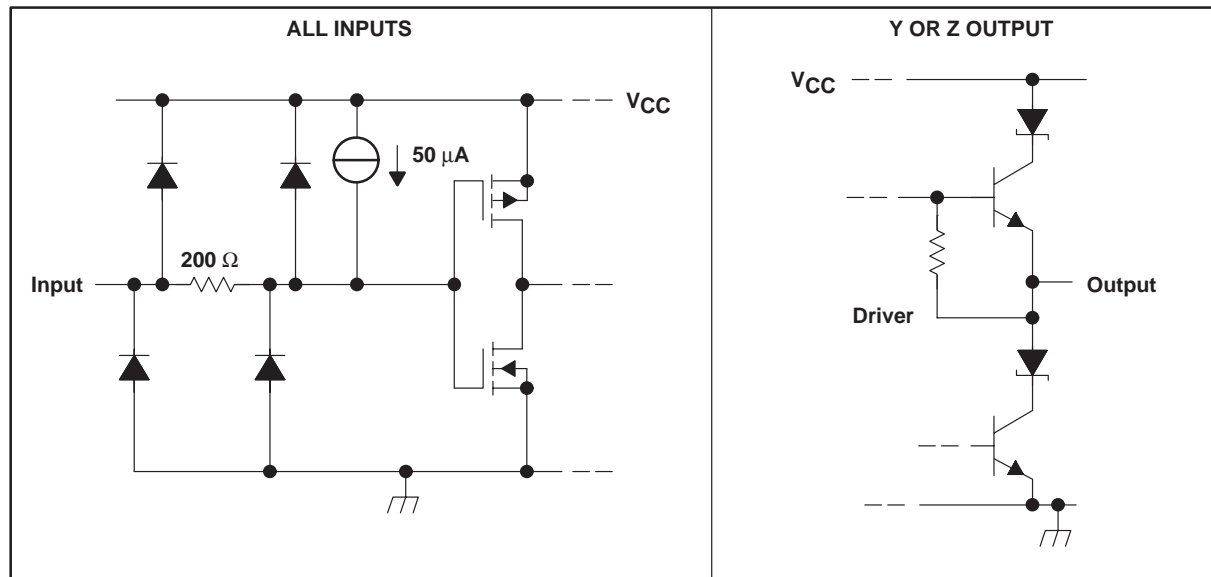

SN55LBC174 QUADRUPLE LOW-POWER DIFFERENTIAL LINE DRIVER

SGLS082 – MARCH 1995

absolute maximum ratings over operating free-air temperature (unless otherwise noted)†

| | |
|--------------------------------------------------------------|---------------------|
| Supply voltage range, V_{CC} (see Note 1) | –0.3 V to 7 V |
| Output voltage range, V_O | –10 V to 15 V |
| Input voltage range, V_I | –0.3 V to 7 V |
| Continuous power dissipation | internally limited‡ |
| Operating free-air temperature range, T_A | –55°C to 125°C |
| Storage temperature range, T_{stg} | –65°C to 150°C |
| Lead temperature 1,6 mm (1/16 inch) from case for 10 seconds | –65°C to 150°C |

† Stresses beyond those listed under “absolute maximum ratings” may cause permanent damage to the device. These are stress ratings only, and functional operation of the device at these or any other conditions beyond those indicated under “recommended operating conditions” is not implied. Exposure to absolute-maximum-rated conditions for extended periods may affect device reliability.

‡ The maximum operating junction temperature is internally limited. Use the dissipation rating table to operate below this temperature.

NOTE 1: All voltage values are with respect to GND.

DISSIPATION RATING TABLE

| PACKAGE | $T_A \leq 25^\circ\text{C}$ POWER RATING | DERATING FACTOR ABOVE $T_A = 25^\circ\text{C}$ | $T_A = 125^\circ\text{C}$ POWER RATING |
|---------|---------------------------------------------|---------------------------------------------------|-------------------------------------------|
| FK | 1375 mW | 11.0 mW/°C | 275 mW |
| J | 1375 mW | 11.0 mW/°C | 275 mW |
| W | 1000 mW | 8.0 mW/°C | 200 mW |

recommended operating conditions

| | | MIN | NOM | MAX | UNIT |
|----------------------------------------------------------------|--------|------|-----|------|------|
| Supply voltage, V_{CC} | | 4.75 | 5 | 5.25 | V |
| High-level input voltage, V_{IH} | | 2 | | | V |
| Low-level input voltage, V_{IL} | | | | 0.8 | V |
| Voltage at any bus terminal (separately or common mode), V_O | Y or Z | | | 12 | V |
| | | | | –7 | |
| High-level output current, I_{OH} | Y or Z | | | –60 | mA |
| Low-level output current, I_{OL} | Y or Z | | | 60 | mA |
| Operating free-air temperature, T_A | | –55 | | 125 | °C |



SN55LBC174

QUADRUPLE LOW-POWER DIFFERENTIAL LINE DRIVER

SGLS082 – MARCH 1995

electrical characteristics over recommended ranges of supply voltage and operating free-air temperature (unless otherwise noted)

| PARAMETER | | TEST CONDITIONS | MIN | TYP† | MAX | UNIT |
|-------------------|-----------------------------------------------------|----------------------------------------------------|------------------|------|---------|------|
| V _{IK} | Input clamp voltage | I _I = -18 mA | | | -1.5 | V |
| V _{OD} | Differential output voltage‡ | R _L = 54 Ω, See Figure 1 | 1.1 | 1.8 | 5 | V |
| | | R _L = 60 Ω, See Figure 2 | 1.1 | 1.7 | 5 | |
| Δ V _{OD} | Change in magnitude of differential output voltage§ | | | | ±0.2 | V |
| V _{OC} | Common-mode output voltage | R _L = 54 Ω, See Figure 1 | | | 3 -1 | V |
| Δ V _{OC} | Change in magnitude of common-mode output voltage§ | | | | | ±0.2 |
| I _O | Output current with power off | V _{CC} = 0, V _O = -7 V to 12 V | | | ±100 | μA |
| I _{OZ} | High-impedance-state output current | V _O = -7 V to 12 V | | | ±100 | μA |
| I _{IH} | High-level input current | V _I = 2.4 V | | | -100 | μA |
| I _{IL} | Low-level input current | V _I = 0.4 V | | | -100 | μA |
| I _{OS} | Short-circuit output current | V _O = -7 V to 12 V | | | ±250 | mA |
| I _{CC} | Supply current (all drivers) | No load | Outputs enabled | | 7 | mA |
| | | | Outputs disabled | | 1.5 | |

† All typical values are at V_{CC} = 5 V and T_A = 25°C.

‡ The minimum V_{OD} specification does not fully comply with EIA Standard RS-485 at operating temperatures below 0°C. The lower output signal should be used to determine the maximum signal transmission distance.

§ Δ|V_{OD}| and Δ|V_{OC}| are the changes in magnitude of V_{OD} and V_{OC}, respectively, that occur when the input is changed from a high level to a low level.

switching characteristics, V_{CC} = 5 V

| PARAMETER | | TEST CONDITIONS | T _A | | MIN | TYP | MAX | UNIT |
|---------------------|-------------------------------------|--------------------------------------|----------------|--|-----|-----|-----|------|
| t _d (OD) | Differential output delay time | R _L = 54 Ω, See Figure 3 | 25°C | | 2 | 11 | 20 | ns |
| | | | -55°C to 125°C | | 2 | | 40 | |
| t _t (OD) | Differential output transition time | R _L = 54 Ω, See Figure 3 | 25°C | | 4 | 15 | 25 | ns |
| | | | -55°C to 125°C | | 4 | | 40 | |
| t _{pZH} | Output enable time to high level | R _L = 110 Ω, See Figure 4 | 25°C | | | | 30 | ns |
| | | | -55°C to 125°C | | | | 40 | |
| t _{pZL} | Output enable time to low level | R _L = 110 Ω, See Figure 5 | 25°C | | | | 30 | ns |
| | | | -55°C to 125°C | | | | 40 | |
| t _{pHZ} | Output disable time from high level | R _L = 110 Ω, See Figure 4 | 25°C | | | | 50 | ns |
| | | | -55°C to 125°C | | | | 90 | |
| t _{pLZ} | Output disable time from low level | R _L = 110 Ω, See Figure 5 | 25°C | | | | 30 | ns |
| | | | -55°C to 125°C | | | | 45 | |



PARAMETER MEASUREMENT INFORMATION

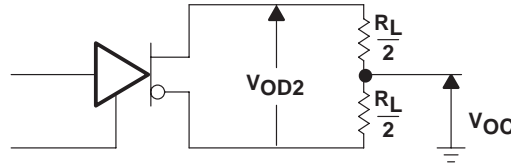

Figure 1. Differential and Common-Mode Output Voltages

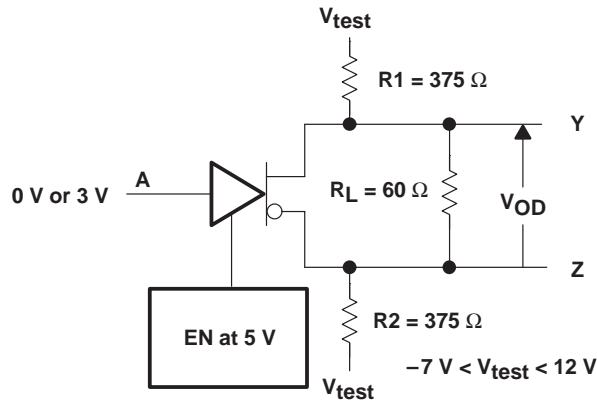
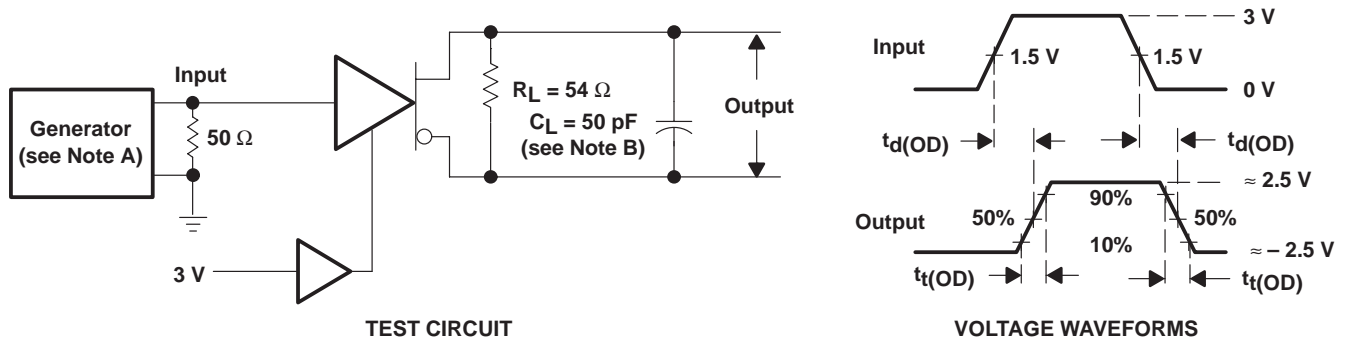

Figure 2. Driver V_{OD} Test Circuit



- NOTES: A. The input pulse is supplied by a generator having the following characteristics: PRR \leq 1 MHz, duty cycle \leq 50%, $t_r \leq$ 5 ns, $t_f \leq$ 5 ns, $Z_O = 50 \Omega$.
 B. C_L includes probe and stray capacitance.

Figure 3. Driver Differential-Output Test Circuit Delay and Transition-Time Waveforms

SN55LBC174 QUADRUPLE LOW-POWER DIFFERENTIAL LINE DRIVER

SGLS082 – MARCH 1995

PARAMETER MEASUREMENT INFORMATION

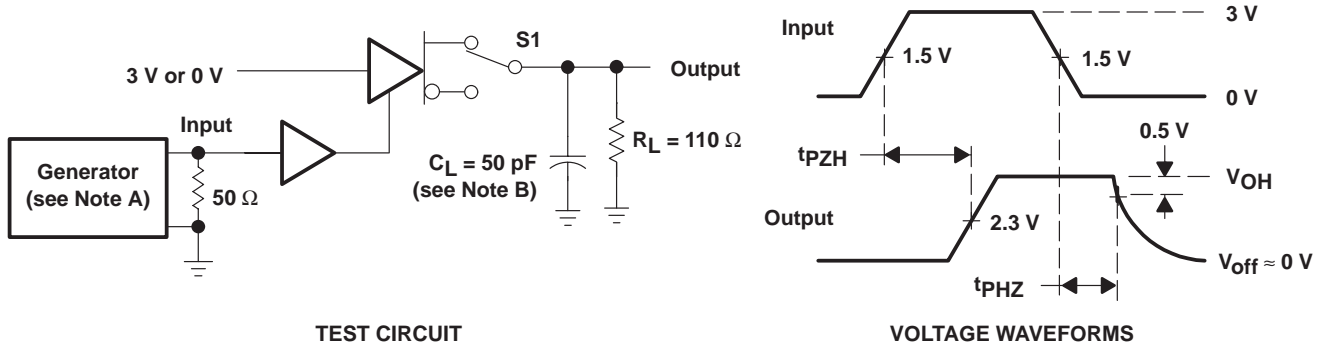

- NOTES: A. The input pulse is supplied by a generator having the following characteristics: PRR \leq 1 MHz, duty cycle \leq 50%, $t_r \leq$ 5 ns, $t_f \leq$ 5 ns, $Z_O = 50 \Omega$.
 B. C_L includes probe and stray capacitance.

Figure 4. t_{pZH} and t_{pHZ} Test Circuit and Waveforms

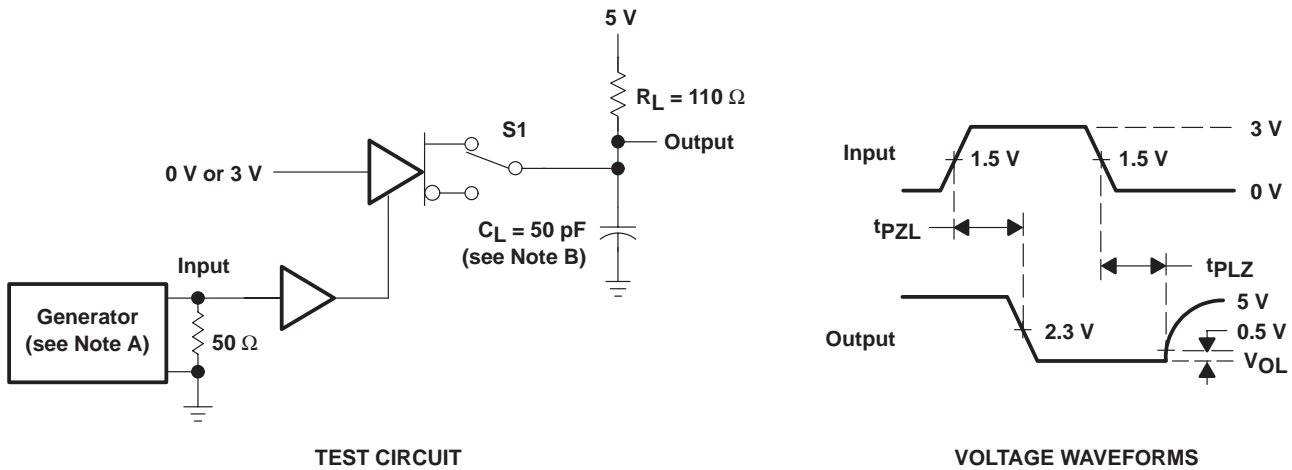

- NOTES: A. The input pulse is supplied by a generator having the following characteristics: PRR \leq 1 MHz, duty cycle \leq 50%, $t_r \leq$ 5 ns, $t_f \leq$ 5 ns, $Z_O = 50 \Omega$.
 B. C_L includes probe and stray capacitance.

Figure 5. t_{pZL} and t_{pLZ} Test Circuit and Waveforms

TYPICAL CHARACTERISTICS

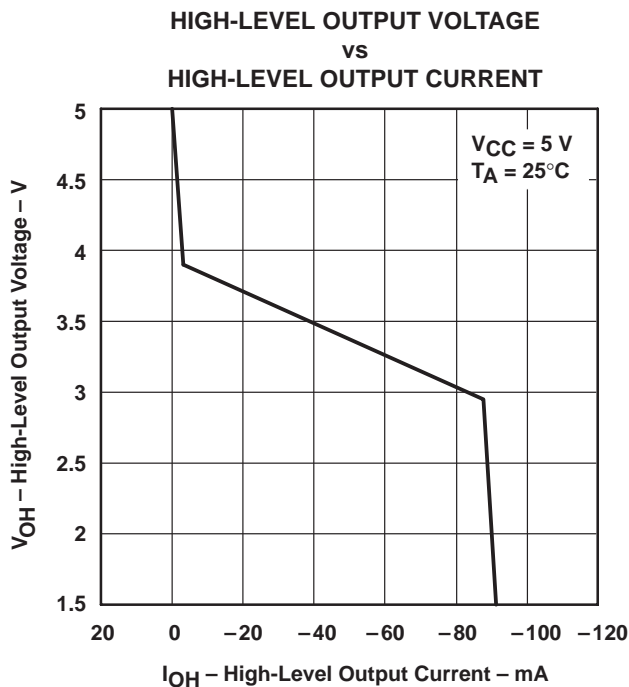
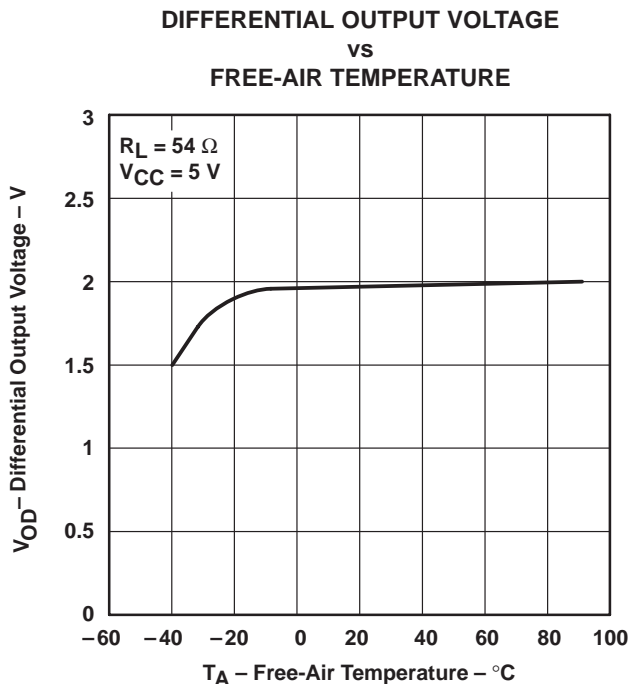
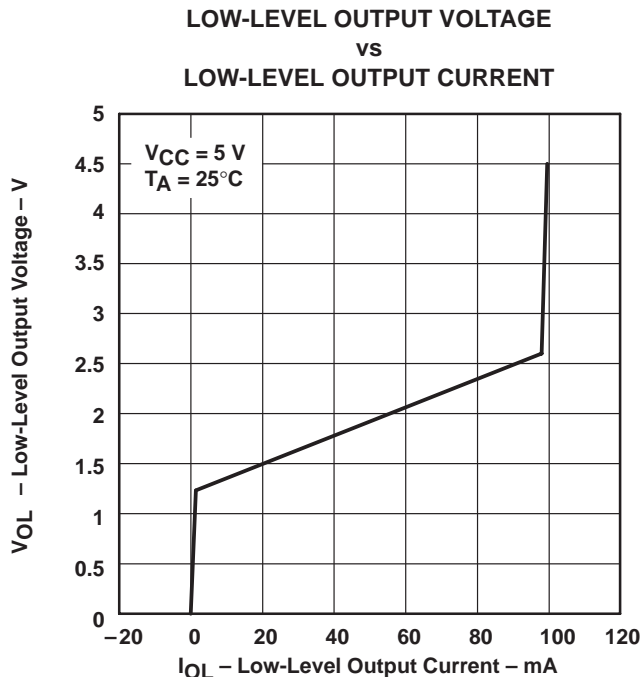
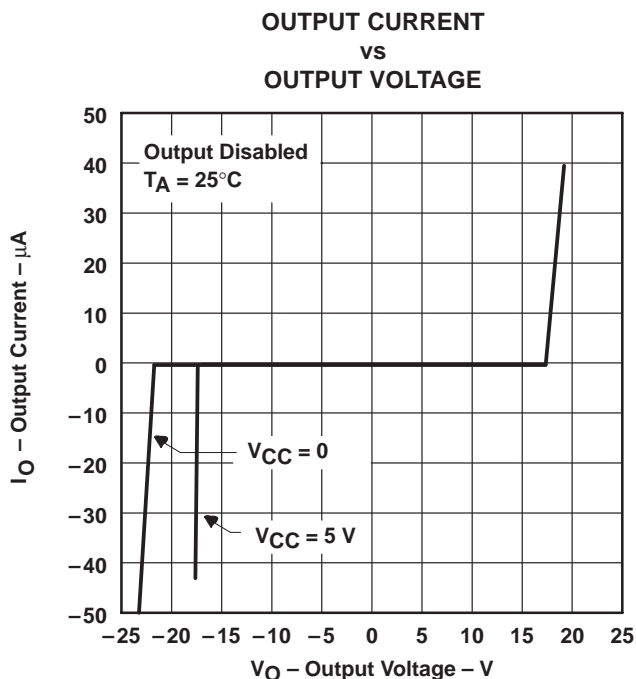

SN55LBC174 QUADRUPLE LOW-POWER DIFFERENTIAL LINE DRIVER

SGLS082 – MARCH 1995

TYPICAL CHARACTERISTICS

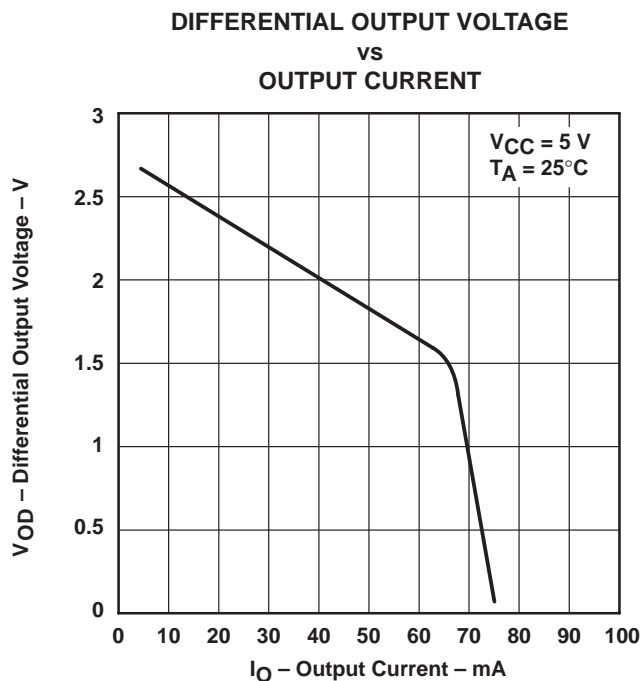

Figure 10

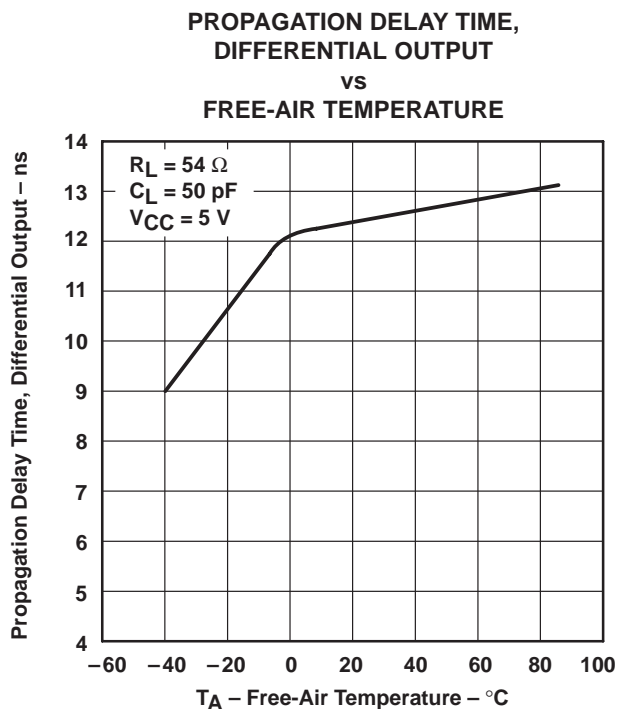

Figure 11



IMPORTANT NOTICE

Texas Instruments and its subsidiaries (TI) reserve the right to make changes to their products or to discontinue any product or service without notice, and advise customers to obtain the latest version of relevant information to verify, before placing orders, that information being relied on is current and complete. All products are sold subject to the terms and conditions of sale supplied at the time of order acknowledgement, including those pertaining to warranty, patent infringement, and limitation of liability.

TI warrants performance of its semiconductor products to the specifications applicable at the time of sale in accordance with TI's standard warranty. Testing and other quality control techniques are utilized to the extent TI deems necessary to support this warranty. Specific testing of all parameters of each device is not necessarily performed, except those mandated by government requirements.

CERTAIN APPLICATIONS USING SEMICONDUCTOR PRODUCTS MAY INVOLVE POTENTIAL RISKS OF DEATH, PERSONAL INJURY, OR SEVERE PROPERTY OR ENVIRONMENTAL DAMAGE ("CRITICAL APPLICATIONS"). TI SEMICONDUCTOR PRODUCTS ARE NOT DESIGNED, AUTHORIZED, OR WARRANTED TO BE SUITABLE FOR USE IN LIFE-SUPPORT DEVICES OR SYSTEMS OR OTHER CRITICAL APPLICATIONS. INCLUSION OF TI PRODUCTS IN SUCH APPLICATIONS IS UNDERSTOOD TO BE FULLY AT THE CUSTOMER'S RISK.

In order to minimize risks associated with the customer's applications, adequate design and operating safeguards must be provided by the customer to minimize inherent or procedural hazards.

TI assumes no liability for applications assistance or customer product design. TI does not warrant or represent that any license, either express or implied, is granted under any patent right, copyright, mask work right, or other intellectual property right of TI covering or relating to any combination, machine, or process in which such semiconductor products or services might be or are used. TI's publication of information regarding any third party's products or services does not constitute TI's approval, warranty or endorsement thereof.