

# TLC32044C, TLC32044E, TLC32044I, TLC32044M, TLC32045C, TLC32045I VOICE-BAND ANALOG INTERFACE CIRCUITS

SLAS017F – MARCH 1988 – REVISED MAY 1995

- 14-Bit Dynamic Range ADC and DAC
- 2's Complement Format
- Variable ADC and DAC Sampling Rate Up to 19,200 Samples per Second
- Switched-Capacitor Antialiasing Input Filter and Output-Reconstruction Filter
- Serial Port for Direct Interface to TMS(SMJ)320C17, TMS(SMJ)32020, TMS(SMJ)320C25, and TMS320C30 Digital Signal Processors
- Synchronous or Asynchronous ADC and DAC Conversion Rates With Programmable Incremental ADC and DAC Conversion Timing Adjustments
- Serial Port Interface to SN74(54)299 Serial-to-Parallel Shift Register for Parallel Interface to TMS(SMJ)32010, TMS(SMJ)320C15, or Other Digital Processors
- Internal Reference for Normal Operation and External Purposes, or Can Be Overridden by External Reference
- CMOS Technology

## description

The TLC32044 and TLC32045 are complete analog-to-digital and digital-to-analog input and output systems on single monolithic CMOS chips. The TLC32044 and TLC32045 integrate a bandpass switched-capacitor antialiasing input filter, a 14-bit-resolution A/D converter, four microprocessor-compatible serial port modes, a 14-bit-resolution D/A converter, and a low-pass switched-capacitor output-reconstruction filter. The devices offer numerous combinations of master clock input frequencies and conversion/sampling rates, which can be changed via digital processor control.

JT OR N PACKAGE  
(TOP VIEW)

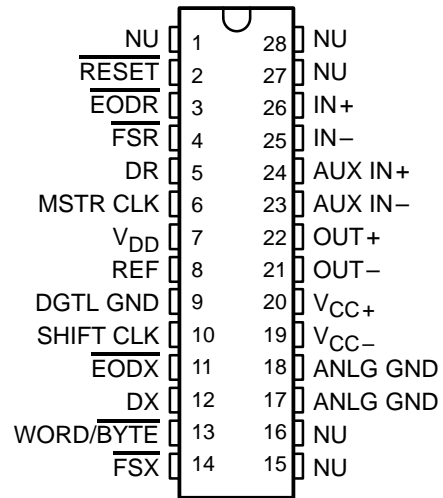

† Refer to the mechanical data for the JT package.

FK OR FN PACKAGE  
(TOP VIEW)

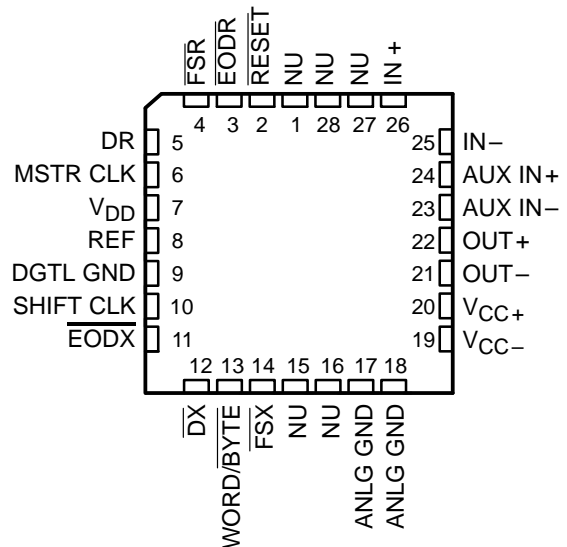

NU – Nonusable; no external connection should be made to these terminals (see Table 2).



Please be aware that an important notice concerning availability, standard warranty, and use in critical applications of Texas Instruments semiconductor products and disclaimers thereto appears at the end of this data sheet.

PRODUCTION DATA information is current as of publication date. Products conform to specifications per the terms of Texas Instruments standard warranty. Production processing does not necessarily include testing of all parameters.

**TEXAS  
INSTRUMENTS**

POST OFFICE BOX 655303 • DALLAS, TEXAS 75265

Copyright © 1995, Texas Instruments Incorporated

# TLC32044C, TLC32044E, TLC32044I, TLC32044M, TLC32045C, TLC32045I

## VOICE-BAND ANALOG INTERFACE CIRCUITS

SLAS017F – MARCH 1988 – REVISED MAY 1995

### AVAILABLE OPTIONS

T <sub>A</sub>	PACKAGE			
	PLASTIC CHIP CARRIER (FN)	PLASTIC DIP (N)	CERAMIC DIP (J)	CHIP CARRIER (FK)
0°C to 70°C	TLC32044CFN	TLC32044CN		
	TLC32045CFN	TLC32045CN		
-20°C to 85°C	TLC32044EFN			
-40°C to 85°C		TLC32044IN		
		TLC32045IN		
-55°C to 125°C			TLC32044MJ	TLC32044MFK

### description (continued)

Typical applications for the TLC32044 and TLC32045 include speech encryption for digital transmission, speech recognition/ storage systems, speech synthesis, modems (7.2-, 8-, 9.6-, 14.4-, and 19.2-kHz sampling rate), analog interface for digital signal processors (DSPs), industrial process control, biomedical instrumentation, acoustical signal processing, spectral analysis, data acquisition, and instrumentation recorders. Four serial modes, which allow direct interface to the TMS(SMJ)320C17, TMS(SMJ)32020, TMS(SMJ)320C25, and TMS(SMJ)320C30 digital signal processors, are provided. Also, when the transmit and receive sections of the analog interface circuit (AIC) are operating synchronously, it will interface to two SN74(54)299 serial-to-parallel shift registers. These serial-to-parallel shift registers can then interface in parallel to the TMS(SMJ)32010, TMS(SMJ)320C15, and other digital signal processors, or external FIFO circuitry. Output data pulses are emitted to inform the processor that data transmission is complete or to allow the DSP to differentiate between two transmitted bytes. A flexible control scheme is provided so that the functions of the TLC32044 or TLC32045 can be selected and adjusted coincidentally with signal processing via software control.

The antialiasing input filter comprises eighth-order and fourth-order CC-type (Chebyshev/elliptic transitional) low-pass and high-pass filters, respectively. The input filter is implemented in switched-capacitor technology and is preceded by a continuous time filter to eliminate any possibility of aliasing caused by sampled data filtering. When only low-pass filtering is desired, the high-pass filter can be switched out of the signal path. A selectable, auxiliary, differential analog input is provided for applications where more than one analog input is required.

The A/D and D/A architectures ensure no missing codes and monotonic operation. An internal voltage reference is provided to ease the design task and to provide complete control over the performance of the TLC32044 or TLC32045. The internal voltage reference is brought out to a terminal and is available to the designer. Separate analog and digital voltage supplies and grounds are provided to minimize noise and ensure a wide dynamic range. Also, the analog circuit path contains only differential circuitry to keep noise to an absolute minimum. The only exception is the DAC sample and hold, which utilizes pseudo-differential circuitry.

The output-reconstruction filter is an eighth-order CC-type (Chebyshev/elliptic transitional low-pass filter) followed by a second-order  $(\sin x)/x$  correction filter and is implemented in switched-capacitor technology. This filter is followed by a continuous-time filter to eliminate images of the digitally encoded signal. The on-board  $(\sin x)/x$  correction filter can be switched out of the signal path using digital signal processor control, if desired.

The TLC32044C and TLC32045C are characterized for operation from 0°C to 70°C. The TLC32044E is characterized for operation from -20°C to 85°C. The TLC32044I and TLC32045I are characterized for operation from -40°C to 85°C. The TLC32044M is characterized for operation from -55°C to 125°C.



functional block diagram

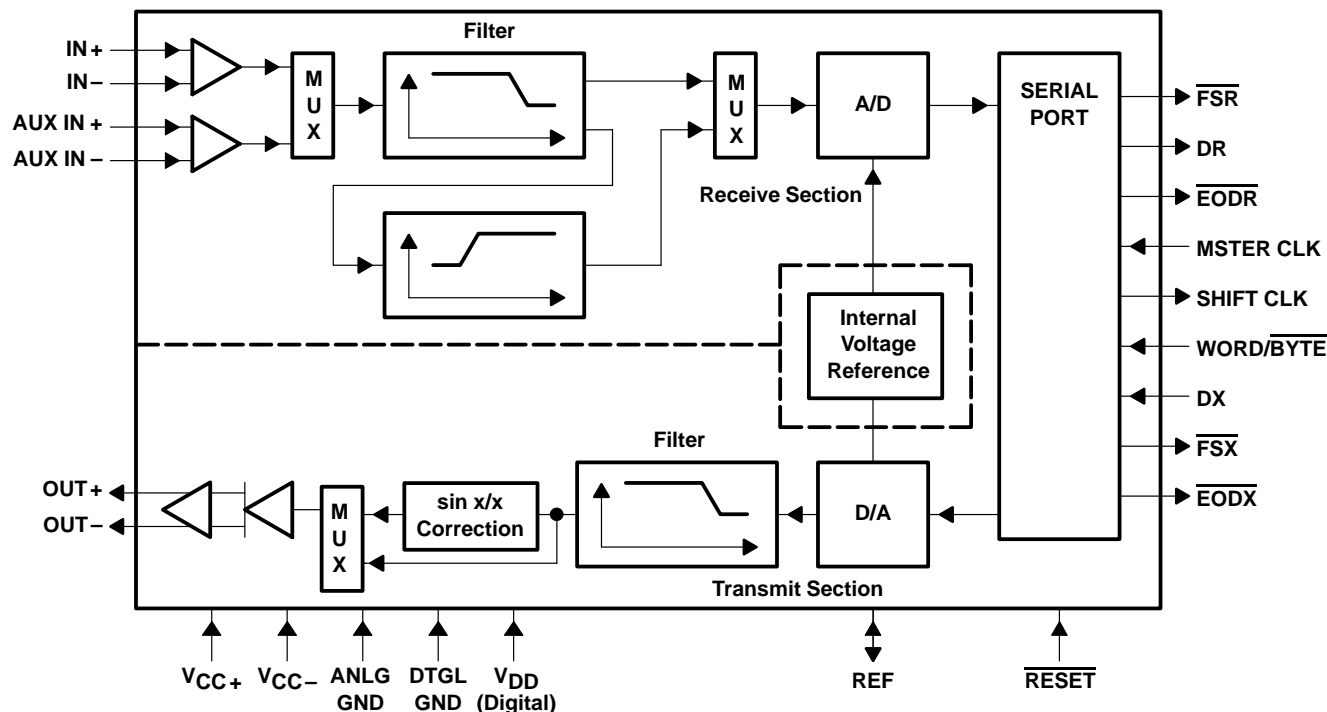

Terminal Functions

TERMINAL NAME	NO.	I/O	DESCRIPTION
ANLG GND	17,18		Analog ground return for all internal analog circuits. Not internally connected to DGTL GND.
AUX IN+	24	I	Noninverting auxiliary analog input stage. AUX IN+ can be switched into the bandpass filter and A/D converter path via software control. If the appropriate bit in the control register is a 1, the auxiliary inputs will replace the IN+ and IN- inputs. If the bit is a 0, the IN+ and IN- inputs will be used (see the AIC DX data word format section).
AUX IN-	23	I	Inverting auxiliary analog input (see the above AUX IN+ description).
DGTL GND	9		Digital ground for all internal logic circuits. Not internally connected to ANLG GND.
DR	5	O	Data receive. DR is used to transmit the ADC output bits from the AIC to the TMS320 (SMJ320) serial port. This transmission of bits from the AIC to the TMS320 (SMJ320) serial port is synchronized with the SHIFT CLK signal.
DX	12	I	Data transmit. DX is used to receive the DAC input bits and timing and control information from the TMS320 (SMJ320). This serial transmission from the TMS320 (SMJ320) serial port to the AIC is synchronized with the SHIFT CLK signal.
EODR	3	O	End of data receive. (See the WORD/BYTE description and Serial Port Timing diagram.) During the word-mode timing, EODR is a low-going pulse that occurs immediately after the 16 bits of A/D information have been transmitted from the AIC to the TMS320 (SMJ320) serial port. EODR can be used to interrupt a microprocessor upon completion of serial communications. Also, EODR can be used to strobe and enable external serial-to-parallel shift registers, latches, or external FIFO RAM, and to facilitate parallel data bus communications between the AIC and the serial-to-parallel shift registers. During the byte-mode timing, EODR goes low after the first byte has been transmitted from the AIC to the TMS320 (SMJ320) serial port and is kept low until the second byte has been transmitted. The DSP can use this low-going signal to differentiate between the two bytes as to which is first and which is second. EODR does not occur after secondary communication.

# TLC32044C, TLC32044E, TLC32044I, TLC32044M, TLC32045C, TLC32045I

## VOICE-BAND ANALOG INTERFACE CIRCUITS

SLAS017F – MARCH 1988 – REVISED MAY 1995

### Terminal Functions (continued)

TERMINAL NAME	NO.	I/O	DESCRIPTION
$\overline{\text{EODX}}$	11	O	End of data transmit. (See the WORD/BYTE description and Serial Port Timing diagram.) During the word-mode timing, $\overline{\text{EODX}}$ is a low-going pulse that occurs immediately after the 16 bits of D/A converter and control or register information have been transmitted from the TMS320 (SMJ320) serial port to the AIC. $\overline{\text{EODX}}$ can be used to interrupt a microprocessor upon the completion of serial communications. Also, $\overline{\text{EODX}}$ can be used to strobe and enable external serial-to-parallel shift registers, latches, or an external FIFO RAM, and to facilitate parallel data-bus communications between the AIC and the serial-to-parallel shift registers. During the byte-mode timing, $\overline{\text{EODX}}$ goes low after the first byte has been transmitted from the TMS320 (SMJ320) serial port to the AIC and is kept low until the second byte has been transmitted. The DSP can use this low-going signal to differentiate between the two bytes as to which is first and which is second.
$\overline{\text{FSR}}$	4	O	Frame sync receive. In the serial transmission modes, which are described in the WORD/BYTE description, $\overline{\text{FSR}}$ is held low during bit transmission. When $\overline{\text{FSR}}$ goes low, the TMS320 (SMJ320) serial port begins receiving bits from the AIC via DR of the AIC. The most significant DR bit is present on DR before $\overline{\text{FSR}}$ goes low. (See Serial Port Timing and Internal Timing Configuration diagrams.) $\overline{\text{FSR}}$ does not occur after secondary communications.
$\overline{\text{FSX}}$	14	O	Frame sync transmit. When $\overline{\text{FSX}}$ goes low, the TMS320 (SMJ320) serial port begins transmitting bits to the AIC via DX of the AIC. In all serial transmission modes, which are described in the WORD/BYTE description, $\overline{\text{FSX}}$ is held low during bit transmission (see Serial Port Timing and Internal Timing Configuration diagrams).
IN+	26	I	Noninverting input to analog input amplifier stage
IN-	25	I	Inverting input to analog input amplifier stage
MSTR CLK	6	I	Master clock. MSTR CLK is used to derive all the key logic signals of the AIC, such as the shift clock, the switched-capacitor filter clocks, and the A/D and D/A timing signals. The Internal Timing Configuration diagram shows how these key signals are derived. The frequencies of these key signals are synchronous submultiples of the master clock frequency to eliminate unwanted aliasing when the sampled analog signals are transferred between the switched-capacitor filters and the A/D and D/A converters (see the Internal Timing Configuration diagram).
OUT+	22	O	Noninverting output of analog output power amplifier. OUT+ can drive transformer hybrids or high-impedance loads directly in either a differential or a single-ended configuration.
OUT-	21	O	Inverting output of analog output power amplifier. OUT- is functionally identical with and complementary to OUT+.
REF	8	I/O	Internal voltage reference. An internal reference voltage is brought out on REF. An external voltage reference can also be applied to REF.
$\overline{\text{RESET}}$	2	I	Reset function. $\overline{\text{RESET}}$ is provided to initialize the TA, TA', TB, RA, RA', RB, and control registers. A reset initiates serial communications between the AIC and DSP. A reset initializes all AIC registers including the control register. After a negative-going pulse on $\overline{\text{RESET}}$ , the AIC registers are initialized to provide an 8-kHz data conversion rate for a 5.184-MHz master clock input signal. The conversion rate adjust registers, TA' and RA', are reset to 1. The control register bits are reset as follows (see AIC DX data word format section): d9 = 1, d7 = 1, d6 = 1, d5 = 1, d4 = 0, d3 = 0, d2 = 1. This initialization allows normal serial-port communication to occur between the AIC and DSP.
SHIFT CLK	10	O	Shift clock. SHIFT CLK is obtained by dividing the master clock signal frequency by four. SHIFT CLK is used to clock the serial data transfers of the AIC, described in the WORD/BYTE description below (see the Serial Port Timing and Internal Timing Configuration diagrams).
VDD	7		Digital supply voltage, 5 V $\pm$ 5%
VCC+	20		Positive analog supply voltage, 5 V $\pm$ 5%
VCC-	19		Negative analog supply voltage, -5 V $\pm$ 5%

# TLC32044C, TLC32044E, TLC32044I, TLC32044M, TLC32045C, TLC32045I VOICE-BAND ANALOG INTERFACE CIRCUITS

SLAS017F – MARCH 1988 – REVISED MAY 1995

## Terminal Functions (continued)

TERMINAL NAME	NO.	I/O	DESCRIPTION
WORD/ <u>BYTE</u>	13	I	<p>Used in conjunction with a bit in the control register, WORD/<u>BYTE</u> is used to establish one of four serial modes. These four serial modes are described below.</p> <p><i>AIC transmit and receive sections are operated asynchronously.</i></p> <p>The following description applies when the AIC is configured to have asynchronous transmit and receive sections. If the appropriate data bit in the control register is a 0 (see the AIC DX data word format section), the transmit and receive sections are asynchronous.</p> <ul style="list-style-type: none"> <li>L Serial port directly interfaces with the serial port of the DSP and communicates in two 8-bit bytes. The operation sequence is as follows (see Serial Port Timing diagrams).               <ol style="list-style-type: none"> <li>1. <u>FSX</u> or <u>FSR</u> is brought low.</li> <li>2. One 8-bit byte is transmitted or one 8-bit byte is received.</li> <li>3. <u>EODX</u> or <u>EODR</u> is brought low.</li> <li>4. <u>FSX</u> or <u>FSR</u> emits a positive frame-sync pulse that is four shift clock cycles wide.</li> <li>5. One 8-bit byte is transmitted or one 8-bit byte is received.</li> <li>6. <u>EODX</u> or <u>EODR</u> is brought high.</li> <li>7. <u>FSX</u> or <u>FSR</u> is brought high.</li> </ol> </li> <li>H Serial port directly interfaces with the serial ports of the TMS(SMJ)32020, TMS(SMJ)320C25, or TMS(SMJ)320C30, and communicates in one 16-bit word. The operation sequence is as follows (see Serial Port Timing diagrams):               <ol style="list-style-type: none"> <li>1. <u>FSX</u> or <u>FSR</u> is brought low.</li> <li>2. One 16-bit word is transmitted or one 16-bit word is received.</li> <li>3. <u>FSX</u> or <u>FSR</u> is brought high.</li> <li>4. <u>EODX</u> or <u>EODR</u> emits a low-going pulse.</li> </ol> </li> </ul> <p><i>AIC transmit and receive sections are operated synchronously.</i></p> <p>If the appropriate data bit in the control register is 1, the transmit and receive sections are configured to be synchronous. In this case, the bandpass switched-capacitor filter and the A/D conversion timing are derived from the TX counter A, TX counter B, and TA, TA', and TB registers, rather than the RX counter A, RX counter B, and RA, RA', and RB registers. In this case, the AIC <u>FSX</u> and <u>FSR</u> timing are identical during primary data communication; however, <u>FSR</u> is not asserted during secondary data communication since there is no new A/D conversion result. The synchronous operation sequences are as follows (see Serial Port Timing diagrams).</p> <ul style="list-style-type: none"> <li>L Serial port directly interfaces with the serial port of the DSP and communicates in two 8-bit bytes. The operation sequence is as follows (see Serial Port Timing diagrams):               <ol style="list-style-type: none"> <li>1. <u>FSX</u> and <u>FSR</u> are brought low.</li> <li>2. One 8-bit byte is transmitted and one 8-bit byte is received.</li> <li>3. <u>EODX</u> and <u>EODR</u> are brought low.</li> <li>4. <u>FSX</u> and <u>FSR</u> emit positive frame-sync pulses that are four shift clock cycles wide.</li> <li>5. One 8-bit byte is transmitted and one 8-bit byte is received.</li> <li>6. <u>EODX</u> and <u>EODR</u> are brought high.</li> <li>7. <u>FSX</u> and <u>FSR</u> are brought high.</li> </ol> </li> <li>H Serial port directly interfaces with the serial port of the TMS(SJM)32020, TMS(SMJ)320C25, or TMS320C30, and communicates in one 16-bit word. The operation sequence is as follows (see Serial Port Timing diagrams):               <ol style="list-style-type: none"> <li>1. <u>FSX</u> and <u>FSR</u> are brought low.</li> <li>2. One 16-bit word is transmitted and one 16-bit word is received.</li> <li>3. <u>FSX</u> and <u>FSR</u> are brought high.</li> <li>4. <u>EODX</u> or <u>EODR</u> emit low-going pulses.</li> </ol> </li> </ul> <p>Since the transmit and receive sections of the AIC are now synchronous, the AIC serial port with additional NOR and AND gates interface to two SN74(54)299 serial-to-parallel shift registers. Interfacing the AIC to the SN74(54)299 shift register allows the AIC to interface to an external FIFO RAM and facilitates parallel, data bus communications between the AIC and the digital signal processor. The operation sequence is the same as the above sequence (see Serial Port Timing diagrams).</p>



# TLC32044C, TLC32044E, TLC32044I, TLC32044M, TLC32045C, TLC32045I

## VOICE-BAND ANALOG INTERFACE CIRCUITS

SLAS017F – MARCH 1988 – REVISED MAY 1995

---

### PRINCIPLES OF OPERATION

#### analog input

Two sets of analog inputs are provided. Normally, the IN+ and IN– input set is used; however, the auxiliary input set, AUX IN + and AUX IN–, can be used if a second input is required. Each input set can be operated in either differential or single-ended modes, since sufficient common-mode range and rejection are provided. The gain for the IN +, IN–, AUX IN +, and AUX IN– inputs can be programmed to be either 1, 2, or 4 (see Table 2). Either input circuit can be selected via software control. It is important to note that a wide dynamic range is assured by the differential internal analog architecture and by the separate analog and digital voltage supplies and grounds.

#### A/D bandpass filter, A/D bandpass filter clocking, and A/D conversion timing

The A/D high-pass filter can be selected or bypassed via software control. The frequency response of this filter is presented in the following pages. This response results when the switched-capacitor filter clock frequency is 288 kHz and the A/D sample rate is 8 kHz. Several possible options can be used to attain a 288-kHz switched-capacitor filter clock. When the filter clock frequency is not 288 kHz, the low-pass filter transfer function is frequency scaled by the ratio of the actual clock frequency to 288 kHz. The ripple bandwidth and 3-dB low-frequency roll-off points of the high-pass section are 150 Hz and 100 Hz, respectively. However, the high-pass section low-frequency roll-off is frequency scaled by the ratio of the A/D sample rate to 8 kHz.

The internal timing configuration and AIC DX data word format sections of this data sheet indicate the many options for attaining a 288-kHz bandpass switched-capacitor filter clock. These sections indicate that the RX counter A can be programmed to give a 288-kHz bandpass switched-capacitor filter clock for several master clock input frequencies.

The A/D conversion rate is then attained by frequency dividing the 288-kHz bandpass switched-capacitor filter clock with the RX counter B. Unwanted aliasing is prevented because the A/D conversion rate is an integral submultiple of the bandpass switched-capacitor filter sampling rate, and the two rates are synchronously locked.

#### A/D converter performance specifications

Fundamental performance specifications for the A/D converter circuitry are presented in the A/D converter operating characteristics section of this data sheet. The realization of the A/D converter circuitry with switched-capacitor techniques provides an inherent sample-and-hold.

#### analog output

The analog output circuitry is an analog output power amplifier. Both noninverting and inverting amplifier outputs are brought out. This amplifier can drive transformer hybrids or low-impedance loads directly in either a differential or single-ended configuration.

#### D/A low-pass filter, D/A low-pass filter clocking, and D/A conversion timing

The frequency response of this filter is presented in the following pages. This response results when the low-pass switched-capacitor filter clock frequency is 288 kHz. Like the A/D filter, the transfer function of this filter is frequency scaled when the clock frequency is not 288 kHz. A continuous-time filter is provided on the output of the  $(\sin x)/x$  correction filter to eliminate the periodic sample data signal information, which occurs at multiples of the 288-kHz switched-capacitor filter clock. The continuous time filter also greatly attenuates any switched-capacitor clock feedthrough.



---

## PRINCIPLES OF OPERATION

### D/A low-pass filter, D/A low-pass filter clocking, and D/A conversion timing (continued)

The D/A conversion rate is attained by frequency dividing the 288-kHz switched-capacitor filter clock with TX Counter B. Unwanted aliasing is prevented because the D/A conversion rate is an integral submultiple of the switched-capacitor low-pass filter sampling rate, and the two rates are synchronously locked.

### asynchronous versus synchronous operation

If the transmit section of the AIC (low-pass filter and DAC) and receive section (bandpass filter and ADC) are operated asynchronously, the low-pass and bandpass filter clocks are independently generated from the master clock signal. Also, the D/A and A/D conversion rates are independently determined. If the transmit and receive sections are operated synchronously, the low-pass filter clock drives both low-pass and bandpass filters. In synchronous operation, the A/D conversion timing is derived from, and is equal to, the D/A conversion timing (see description of the WORD/BYTE in the Terminal Functions table.)

### D/A converter performance specifications

Fundamental performance specifications for the D/A converter circuitry are presented in the D/A converter operating characteristics section of the data sheet. The D/A converter has a sample-and-hold that is realized with a switched-capacitor ladder.

### system frequency response correction

The  $(\sin x)/x$  correction for the D/A converter zero-order sample-and-hold output can be provided by an on-board second-order  $(\sin x)/x$  correction filter. This  $(\sin x)/x$  correction filter can be inserted into or deleted from the signal path by digital signal processor control. When inserted, the  $(\sin x)/x$  correction filter follows the switched-capacitor low-pass filter. When the TB register (see Internal Timing Configuration section) equals 36, the correction results of Figures 11 and 12 can be obtained.

The  $(\sin x)/x$  correction can also be accomplished by deleting the on-board second-order correction filter and performing the  $(\sin x)/x$  correction in digital signal processor software. The system frequency response can be corrected via DSP software to  $\pm 0.1$ -dB accuracy to a band edge of 3000 Hz for all sampling rates. This correction is accomplished with a first-order digital correction filter, which requires only seven TMS320 (SMJ320) instruction cycles. With a 200-ns instruction cycle, seven instructions represent an overhead factor of only 1.1% and 1.3% for sampling rates of 8 and 9.6 kHz, respectively (see the  $(\sin x)/x$  correction section for more details).

### serial port

The serial port has four possible modes that are described in detail in the Terminal Functions table. These modes are briefly described below and in the functional description for WORD/BYTE.

- The transmit and receive sections are operated asynchronously, and the serial port interfaces directly with the DSP.
- The transmit and receive sections are operated asynchronously, and the serial port interfaces directly with the TMS(SMJ)32020, TMS(SMJ)320C25, and the TMS(SMJ)320C30.
- The transmit and receive sections are operated synchronously, and the serial port interfaces directly with the DSP.
- The transmit and receive sections are operated synchronously, and the serial port interfaces directly with the TMS(SMJ)32020, TMS(SMJ)320C25, TMS(SMJ)320C30, or two SN74(54)299 serial-to-parallel shift registers, which can then interface in parallel to the TMS(SMJ)32010, TMS(SMJ)320C15, and SMJ320E15 to any other digital signal processor or to external FIFO circuitry.

# TLC32044C, TLC32044E, TLC32044I, TLC32044M, TLC32045C, TLC32045I VOICE-BAND ANALOG INTERFACE CIRCUITS

SLAS017F – MARCH 1988 – REVISED MAY 1995

---

## PRINCIPLES OF OPERATION

### operation of TLC32044 or TLC32045 with internal voltage reference

The internal reference eliminates the need for an external voltage reference and provides overall circuit cost reduction. Thus, the internal reference eases the design task and provides complete control over device performance. The internal reference is brought out to a terminal and is available to the designer. To keep the amount of noise on the reference signal to a minimum, an external capacitor can be connected between REF and ANLG GND.

### operation of TLC32044 or TLC32045 with external voltage reference

REF can be driven from an external reference circuit. This external circuit must be capable of supplying 250  $\mu$ A and must be adequately protected from noise such as crosstalk from the analog input.

### reset

A reset function is provided to initiate serial communications between the AIC and DSP and to allow fast, cost-effective testing during manufacturing. The reset function initializes all AIC registers, including the control register. After a negative-going pulse on  $\overline{\text{RESET}}$ , the AIC is initialized. This initialization allows normal serial port communications activity to occur between AIC and DSP (see AIC DX data word format section).

### loopback

This feature allows the user to test the circuit remotely. In loopback, OUT+ and OUT– are internally connected to the IN+ and IN–. Thus, the DAC bits (d15 to d2), which are transmitted to DX, can be compared with the ADC bits (d15 to d2), which are received from DR. An ideal comparison would be that the bits on DR equal the bits on DX. However, there are some difference in these bits due to the ADC and DAC output offsets. The loopback feature is implemented with digital signal processor control by transmitting the appropriate serial port bit to the control register (see AIC DX data word format section).





# TLC32044C, TLC32044E, TLC32044I, TLC32044M, TLC32045C, TLC32045I VOICE-BAND ANALOG INTERFACE CIRCUITS

SLAS017F – MARCH 1988 – REVISED MAY 1995

## INTERNAL TIMING CONFIGURATION

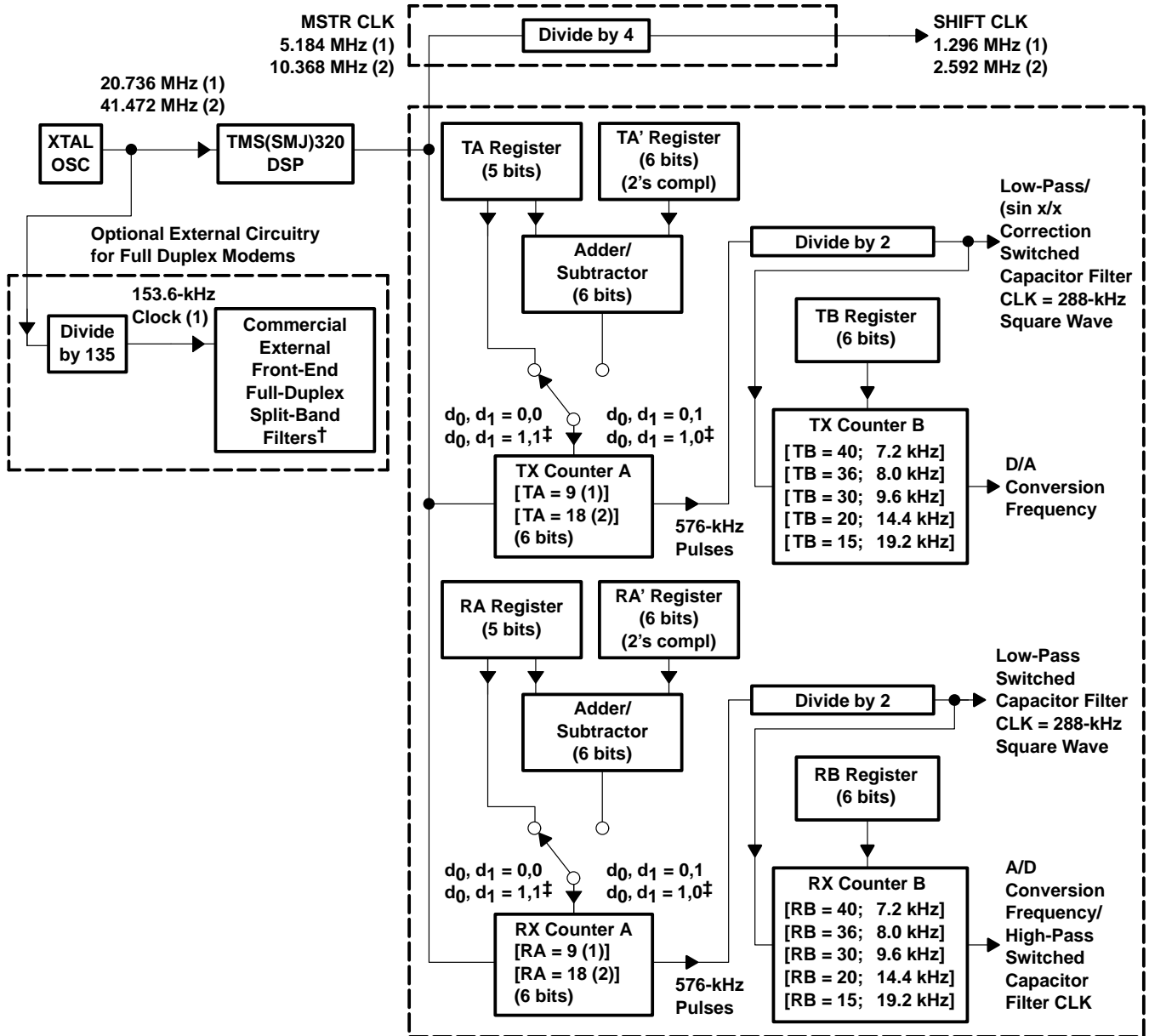

† Split-band filtering can alternatively be performed after the analog input function via software in the TMS(SMJ)320.

‡ These control bits are described in the AIC DX data word format section.

NOTE: Frequency 1 (20.736 MHz) is used to show how 153.6 kHz (for a commercially available modem split-band filter clock), popular speech and modem sampling signal frequencies, and an internal 288-kHz switched-capacitor filter clock can be derived synchronously and as submultiples of the crystal oscillator frequency. Since these derived frequencies are synchronous submultiples of the crystal frequency, aliasing does not occur as the sampled analog signal passes between the analog converter and switched-capacitor filter stages. Frequency 2 (41.472 MHz) is used to show that the AIC can work with high-frequency signals, which are used by high-speed digital signal processors.

# TLC32044C, TLC32044E, TLC32044I, TLC32044M, TLC32045C, TLC32045I

## VOICE-BAND ANALOG INTERFACE CIRCUITS

SLAS017F – MARCH 1988 – REVISED MAY 1995

---

### explanation of internal timing configuration

All of the internal timing of the AIC is derived from the high-frequency clock signal that drives the master clock input. The shift clock signal, which strobes the serial port data between the AIC and DSP, is derived by dividing the master clock input signal frequency by four.

Low-pass:

$$\text{SCF Clock Frequency (D/A or A/D path)} = \frac{\text{Master Clock Frequency}}{2 \times \text{Contents of Counter A}}$$

$$\text{Conversion Frequency} = \frac{\text{SCF Clock Frequency (D/A or A/D path)}}{\text{Contents of Counter B}}$$

High-pass:

$$\text{SCF Clock Frequency (A/D Path)} = \text{A/D Conversion Frequency}$$

$$\text{Shift Clock Frequency} = \frac{\text{Master Clock Frequency}}{4}$$

TX counter A and TX counter B, which are driven by the master clock, determine the D/A conversion timing. Similarly, RX counter A and RX counter B determine the A/D conversion timing. In order for the low-pass switched-capacitor filter in the D/A path to meet its transfer function specifications, the frequency of its clock input must be 288 kHz. If the clock frequency is not 288 kHz, the filter transfer function frequencies are frequency-scaled by the ratios of the clock frequency to 288 kHz. Thus, to obtain the specified filter response, the combination of master clock frequency and TX counter A and RX counter A values must yield a 288-kHz switched-capacitor clock signal. This 288-kHz clock signal can then be divided by the TX counter B to establish the D/A conversion timing.

The transfer function of the bandpass switched-capacitor filter in the A/D path is a composite of its high-pass and low-pass section transfer functions. The high-frequency roll-off of the low-pass section meets the bandpass filter transfer function specification when the low-pass section SCF is 288 kHz. Otherwise, the high-frequency roll-off will be frequency-scaled by the ratio of the high-pass section's SCF clock to 288 kHz. The low-frequency roll-off of the high-pass section meets the bandpass filter transfer function specification when the A/D conversion rate is 8 kHz. Otherwise, the low-frequency roll-off of the high-pass section is frequency-scaled by the ratio of the A/D conversion rate to 8 kHz.

TX counter A and TX counter B are reloaded every D/A conversion period, while RX counter A and RX counter B are reloaded every A/D conversion period. The TX counter B and RX counter B are loaded with the values in the TB and RB registers, respectively. Via software control, the TX counter A can be loaded with either the TA register, the TA register less the TA' register, or the TA register plus the TA' register. By selecting the TA register less the TA' register option, the upcoming conversion timing occurs earlier by an amount of time that equals TA' times the signal period of the master clock. By selecting the TA register plus the TA' register option, the upcoming conversion timing occurs later by an amount of time that equals TA' times the signal period of the master clock. The D/A conversion timing can be advanced or retarded. An identical ability to alter the A/D conversion timing is provided. In this case, however, the RX counter A can be programmed via software control with the RA register, the RA register less the RA' register, or the RA register plus the RA' register.

The ability to advance or retard conversion timing is particularly useful for modem applications. This feature allows controlled changes in the A/D and D/A conversion timing. This feature can be used to enhance signal-to-noise performance, to perform frequency-tracking functions, and to generate nonstandard modem frequencies.



POST OFFICE BOX 655303 • DALLAS, TEXAS 75265

### explanation of internal timing configuration (continued)

If the transmit and receive sections are configured to be synchronous (see WORD/BYTE description), then both the low-pass and bandpass switched-capacitor filter clocks are derived from TX counter A. Also, both the D/A and A/D conversion timing are derived from the TX counter A and TX counter B. When the transmit and receive sections are configured to be asynchronous, the RX counter A, RX counter B, RA register, RA' register, and RB registers are not used.

### AIC DR or DX word bit pattern

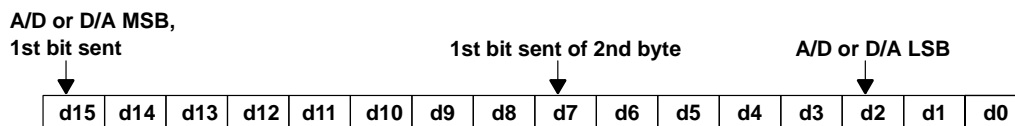

### AIC DX data word format section

d15	d14	d13	d12	d11	d10	d9	d8	d7	d6	d5	d4	d3	d2	d1	d0	Comments	
<b>primary DX serial communication protocol</b>																	
←d15 (MSB) through d2 go to the D/A converter register														→	0	0	The TX and RX counter As are loaded with the TA and RA register values. The TX and RX counter Bs are loaded with TB and RB register values.
←d15 (MSB) through d2 go to the D/A converter register														→	0	1	The TX and RX counter As are loaded with the TA + TA' and RA + RA' register values. The TX and RX counter Bs are loaded with the TB and RB register values. LSBs d1 = 0 and d0 = 1 cause the next D/A and A/D conversion periods to be changed by the addition of TA' and RA' master clock cycles, in which TA' and RA' can be positive or negative or zero (refer to Table 1).
←d15 (MSB) through d2 go to the D/A converter register														→	1	0	The TX and RX counter As are loaded with the TA – TA' and RA – RA' register values. The TX and RX counter Bs are loaded with the TB and RB register values. LSBs d1 = 1 and d0 = 0 cause the next D/A and A/D conversion periods to be changed by the subtraction of TA' and RA' master clock cycles, in which TA' and RA' can be positive or negative or zero (refer to Table 1).
←d15 (MSB) through d2 go to the D/A converter register														→	1	1	The TX and RX counter As are loaded with the TA and RA register converter register values. The TX and RX counter Bs are loaded with the TB and RB register values. After a delay of four shift clock cycles, a secondary transmission immediately follows to program the AIC to operate in the desired configuration.

NOTE: Setting the two least significant bits to 1 in the normal transmission of DAC information (primary communications) to the AIC initiates secondary communications upon completion of the primary communications. Upon completion of the primary communication, FSR remains high for four shift clock cycles and then goes low and initiates the secondary communication. The timing specifications for the primary and secondary communications are identical. In this manner, the secondary communication, if initiated, is interleaved between successive primary communications. This interleaving prevents the secondary communication from interfering with the primary communications and DAC timing, thus preventing the AIC from skipping a DAC output. In the synchronous mode, FSR is not asserted during secondary communications.

# TLC32044C, TLC32044E, TLC32044I, TLC32044M, TLC32045C, TLC32045I

## VOICE-BAND ANALOG INTERFACE CIRCUITS

SLAS017F – MARCH 1988 – REVISED MAY 1995

### secondary DX serial communication protocol

$x\ x \leftarrow$ to TA register $\rightarrow$ $x\ x \leftarrow$ to RA register $\rightarrow$	0 0	d13 and d6 are MSBs (unsigned binary)
$x \leftarrow$ to TA' register $\rightarrow$ $x \leftarrow$ to RA' register $\rightarrow$	0 1	d14 and d7 are 2's complement sign bits
$x \leftarrow$ to TB register $\rightarrow$ $x \leftarrow$ to RB register $\rightarrow$	1 0	d14 and d7 are MSBs (unsigned binary)
$x\ x\ x\ x\ x\ x\ x\ d9$ $x\ d7\ d6\ d5\ d4\ d3\ d2\ 1\ 1$ 		d2 = 0/1    deletes/inserts the A/D high-pass filter d3 = 0/1    disables/enables the loopback function d4 = 0/1    disables/enables the AUX IN+ and AUX IN- d5 = 0/1    asynchronous/synchronous transmit and receive sections d6 = 0/1    gain control bits (see gain control section) d7 = 0/1    gain control bits (see gain control section) d9 = 0/1    delete/insert on-board second-order (sin x)/x correction filter

### reset function

A reset function is provided to initiate serial communications between the AIC and DSP. The reset function initializes all AIC registers, including the control register. After power has been applied to the AIC, a negative-going pulse on  $\overline{\text{RESET}}$  initializes the AIC registers to provide an 8-kHz A/D and D/A conversion rate for a 5.184 MHz master clock input signal. The AIC, except the control register, is initialized as follows (see AIC DX data word format section):

REGISTER	INITIALIZED REGISTER VALUE (HEX)
TA	9
TA'	1
TB	24
RA	9
RA'	1
RB	24

The control register bits are reset as follows (see AIC DX data word format section):

$$d9 = 1, d7 = 1, d6 = 1, d5 = 1, d4 = 0, d3 = 0, d2 = 1$$

This initialization allows normal serial port communications to occur between AIC and DSP. If the transmit and receive sections are configured to operate synchronously and the user wishes to program different conversion rates, only the TA, TA', and TB register need to be programmed, since both transmit and receive timing are synchronously derived from these registers (see the terminal functions table and AIC DX word format sections).

The circuit shown in Figure 1 provides a reset on power up when power is applied in the sequence given under power-up sequence. The circuit depends on the power supplies reaching their recommended values a minimum of 800 ns before the capacitor charges to 0.8 V above DGTL GND.

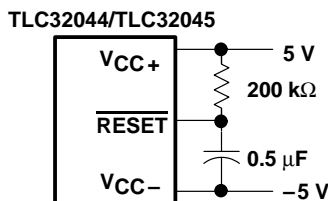

Figure 1. Power-Up Reset

### power-up sequence

To ensure proper operation of the AIC and as a safeguard against latch-up, it is recommended that Schottky diodes with forward voltages less than or equal to 0.4 V be connected from  $V_{CC-}$  to ANLG GND and from  $V_{CC-}$  to DGTL GND (see Figure 21). In the absence of such diodes, power should be applied in the following sequence: ANLG GND and DGTL GND,  $V_{CC-}$ , then  $V_{CC+}$  and  $V_{DD}$ . Also, no input signal should be applied until after power up.

### AIC responses to improper conditions

The AIC has provisions for responding to improper conditions. These improper conditions and the response of the AIC to these conditions are presented in Table 1 below.

### AIC register constraints

The following constraints are placed on the contents of the AIC registers:

1. TA register must be  $\geq 4$  in word mode ( $WORD/\overline{BYTE} = \text{high}$ ).
2. TA register must be  $\geq 5$  in byte mode ( $WORD/\overline{BYTE} = \text{low}$ ).
3. TA' register can be either positive, negative, or zero.
4. RA register must be  $\geq 4$  in word mode ( $WORD/\overline{BYTE} = \text{high}$ ).
5. RA register must be  $\geq 5$  in byte mode ( $WORD/\overline{BYTE} = \text{low}$ ).
6. RA' register can be either positive, negative, or zero.
7. (TA register  $\pm$  TA' register) must be  $> 1$ .
8. (RA register  $\pm$  RA' register) must be  $> 1$ .
9. TB register must be  $> 1$ .

**Table 1. AIC Responses to Improper Conditions**

IMPROPER CONDITION	AIC RESPONSE
TA register + TA' register = 0 or 1 TA register – TA' register = 0 or 1	Reprogram TX counter A with TA register value
TA register + TA' register < 0	MODULO 64 arithmetic is used to ensure that a positive value is loaded into the TX counter A, i.e., TA register + TA' register + 40 hex is loaded into TX counter A.
RA register + RA' register = 0 or 1 RA register – RA' register = 0 or 1	Reprogram RX counter A with RA register value
RA register + RA' register = 0 or 1	MODULO 64 arithmetic is used to ensure that a positive value is loaded into RX counter A, i.e., RA register + RA' register + 40 hex is loaded into RX counter A.
TA register = 0 or 1 RA register = 0 or 1	AIC is shut down.
TA register < 4 in word mode TA register < 5 in byte mode RA register < 4 in word mode RA register < 5 in byte mode	The AIC serial port no longer operates.
TB register = 0 or 1	Reprogram TB register with 24 hex
RB register = 0 or 1	Reprogram RB register with 24 hex
AIC and DSP cannot communicate	Hold last DAC output

# TLC32044C, TLC32044E, TLC32044I, TLC32044M, TLC32045C, TLC32045I VOICE-BAND ANALOG INTERFACE CIRCUITS

SLAS017F – MARCH 1988 – REVISED MAY 1995

## improper operation due to conversion times being too close together

If the difference between two successive D/A conversion frame syncs is less than 1/19.2 kHz, the AIC operates improperly. In this situation, the second D/A conversion frame sync occurs too quickly and there is not enough time for the ongoing conversion to be completed. This situation can occur if the A and B registers are improperly programmed or if the A + A' register or A - A' register result is too small. When incrementally adjusting the conversion period via the A + A' register options, the designer should be careful not to violate this requirement (see following diagram).

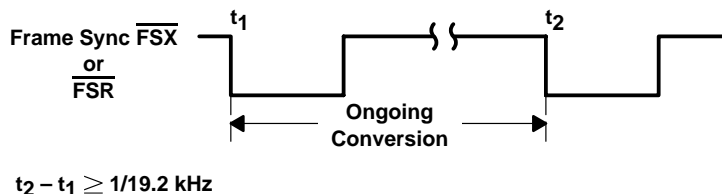

## asynchronous operation — more than one receive frame sync occurring between two transmit frame syncs

When incrementally adjusting the conversion period via the A + A' or A - A' register options, a specific protocol is followed. The command to use the incremental conversion period adjust option is sent to the AIC during a  $\overline{\text{FSX}}$  frame sync. The ongoing conversion period is then adjusted. However, either receive conversion period A or B can be adjusted. For both transmit and receive conversion periods, the incremental conversion period adjustment is performed near the end of the conversion period. Therefore, if there is sufficient time between  $t_1$  and  $t_2$ , the receive conversion period adjustment is performed during receive conversion period A. Otherwise, the adjustment is performed during receive conversion period B. The adjustment command only adjusts one transmit conversion period and one receive conversion period. To adjust another pair of transmit and receive conversion periods, another command must be issued during a subsequent  $\overline{\text{FSX}}$  frame (see figure below).

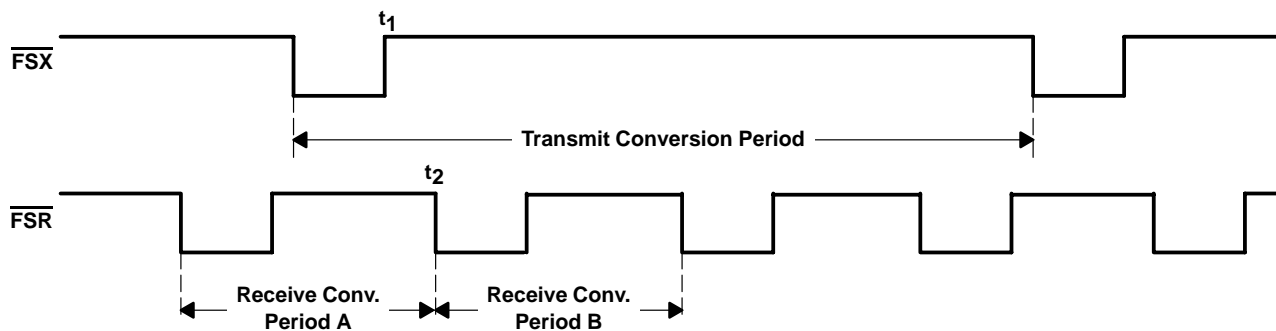

Figure 2. Adjusted Transmit and Receive Conversion Periods

## asynchronous operation — more than one transmit frame sync occurring between two receive frame syncs

When incrementally adjusting the conversion period via the A + A' or A - A' register options, a specific protocol is followed. For both transmit and receive conversion periods, the incremental conversion period adjustment is performed near the end of the conversion period. The command to use the incremental conversion period adjust options is sent to the AIC during a  $\overline{\text{FSX}}$  frame sync. The ongoing transmit conversion period is then adjusted. However, three possibilities exist for the receive conversion period adjustment in the diagram as shown in the following figure. If the adjustment command is issued during transmit conversion period A, receive conversion period A is adjusted if there is sufficient time between  $t_1$  and  $t_2$ . If there is not sufficient time between  $t_1$  and  $t_2$ , receive conversion period B is adjusted. The receive portion of an adjustment command can be



POST OFFICE BOX 655303 • DALLAS, TEXAS 75265

ignored if the adjustment command is sent during a receive conversion period, which is already being or will be adjusted due to a prior adjustment command. For example, if adjustment commands are issued during transmit conversion periods A, B, and C, the first two commands can cause receive conversion periods A and B to be adjusted, while the third receive adjustment command is ignored. The third adjustment command is ignored since it was issued during receive conversion period B, which already is adjusted via the transmit conversion period B adjustment command.

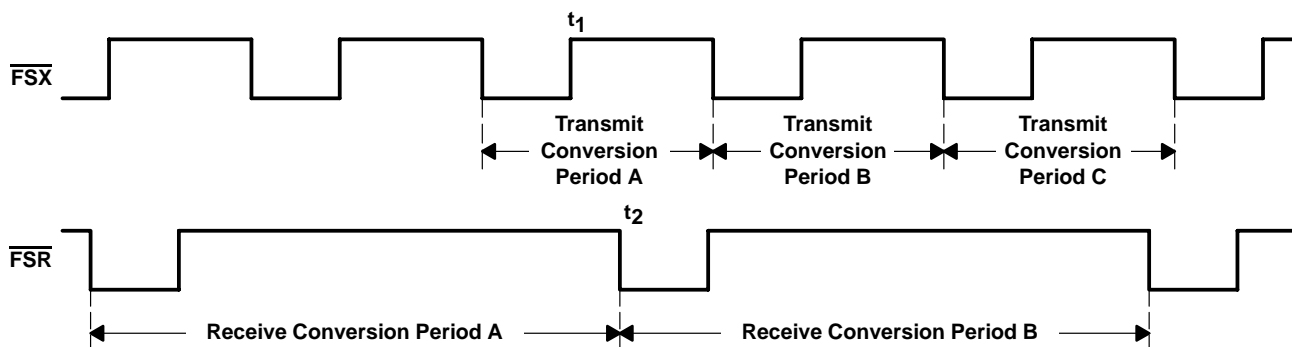

Figure 3. Receive and Transmit Conversion Period Adjustments

**asynchronous operation — more than one set of primary and secondary DX serial communication occurring between two receive frame sync (see AIC DX data word format section)**

The TA, TA', TB, and control register information that is transmitted in the secondary communications is always accepted and is applied during the ongoing transmit conversion period. If there is sufficient time between  $t_1$  and  $t_2$ , the TA, RA', and RB register information, which is sent during transmit conversion period A, is applied to receive conversion period A. Otherwise, this information is applied during receive conversion period B. If RA, RA', and RB register information has already been received and is being applied during an ongoing conversion period, any subsequent RA, RA', or RB information that is received during this receive conversion period is disregarded (see Figure 4).

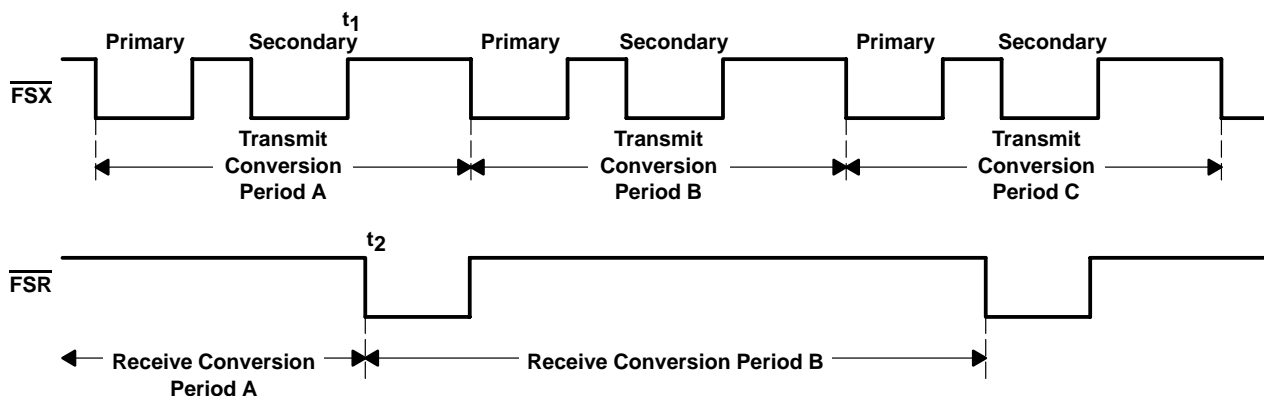

Figure 4. Receive and Transmit Periods for Primary and Secondary Data

# TLC32044C, TLC32044E, TLC32044I, TLC32044M, TLC32045C, TLC32045I

## VOICE-BAND ANALOG INTERFACE CIRCUITS

SLAS017F – MARCH 1988 – REVISED MAY 1995

### test modes†

The TLC32044 or TLC32045 can be operated in special test modes. These test modes are used by Texas Instruments to facilitate testing of the device during manufacturing. They are not intended to be used in real applications; however, they allow the filters in the A/D and D/A paths to be used without using the A/D and D/A converters.

In normal operation, the nonusable (NU) terminals are left unconnected. These NU terminals are used by the factory to speed up testing of the TLC32044 or TLC32045 analog interface circuits (AIC). When the device is used in normal (non-test mode) operation, the NU terminal (terminal 1) has an internal pulldown to  $-5$  V. Externally connecting 0 V or 5 V to terminal 1 puts the device in test-mode operation. Selecting one of the possible test modes is accomplished by placing a particular voltage on certain terminals. A description of these modes is provided in Table 2 and Figures 5 and 6.

**Table 2. List of Test Modes**

TEST TERMINALS	D/A PATH TEST (TERMINAL 1 to 5 V)	A/D PATH TEST (TERMINAL 1 to 0)
	TEST FUNCTION	TEST FUNCTION
5	The low-pass switched-capacitor filter clock is brought out to DR. This clock signal is normally internal.	The bandpass switched-capacitor filter clock is brought out to DR. This clock signal is normally internal.
11	No change from normal operation. The $\overline{\text{EODX}}$ signal is brought out to $\overline{\text{EODX}}$ .	The pulse that initiates the A/D conversion is brought out here. This signal is normally internal.
3	The pulse that initiates the D/A conversion is brought out here.	No change from normal operation. The $\overline{\text{EODR}}$ signal is brought out.
27 and 28	There are no test output signals provided on these terminals.	The outputs of the A/D path low-pass or bandpass filter (depending upon control bit d2 – see AIC DX data word format section) are brought out to these terminals. If the high-pass section is inserted, the output will have a $(\sin x)/x$ droop. The slope of the droop is determined by the ADC sampling frequency, which is the high-pass section clock frequency (see diagram of bandpass or low-pass filter test for receive section). These outputs drive small (30-pF) loads.
15 and 16	<b>D/A PATH LOW-PASS FILTER TEST: (WORD/BYTE) to <math>-5</math> V</b>	
	<b>TEST FUNCTION</b>	
	The inputs of the D/A path low-pass filter are brought out to terminals 15 and 16. The D/A input to this filter is removed. If $(\sin x)/x$ correction filter is inserted, the OUT + and OUT – signals have a flat response (see Figure 2). The common-mode range of these inputs must not exceed $\pm 0.5$ V.	

† In the test mode, the AIC responds to the setting of WORD/BYTE to  $-5$  V, as if WORD/BYTE were set to 0 V. Thus, the byte mode is selected for communicating between DSP and AIC. Either of the path tests (D/A or A/D) can be performed simultaneously with the D/A low-pass filter test. In this situation, WORD/BYTE must be connected to  $-5$  V, which initiates byte-mode communications.





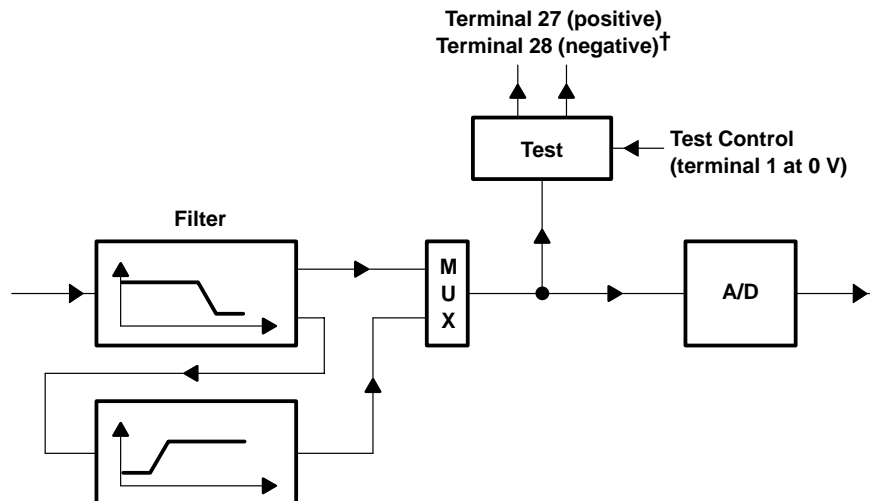

† All analog signal paths have differential architecture and hence have positive and negative components.

**Figure 5. Bandpass or Low-Pass Filter Test for Receiver Section**

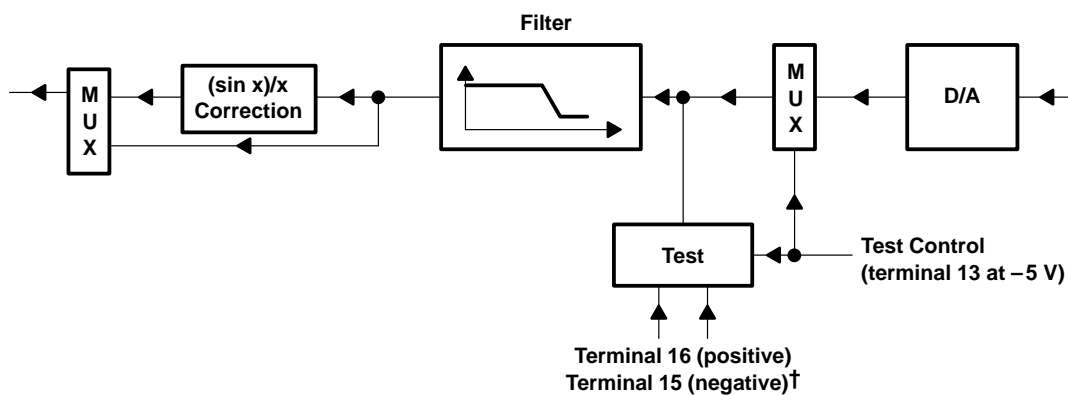

† All analog signal paths have differential architecture and hence have positive and negative components.

**Figure 6. Low-Pass Filter Test for Transmit Section**

# TLC32044C, TLC32044E, TLC32044I, TLC32044M, TLC32045C, TLC32045I

## VOICE-BAND ANALOG INTERFACE CIRCUITS

SLAS017F – MARCH 1988 – REVISED MAY 1995

### absolute maximum ratings over operating free-air temperature range (unless otherwise noted)†

Supply voltage range, $V_{CC+}$ (see Note 1)	–0.3 V to 15 V
Supply voltage range, $V_{DD}$	–0.3 V to 15 V
Output voltage range, $V_O$	–0.3 V to 15 V
Input voltage range, $V_I$	–0.3 V to 15 V
Digital ground voltage range	–0.3 V to 15 V
Operating free-air temperature range: TLC32044C, TLC32045C	0°C to 70°C
TLC32044E	–20°C to 85°C
TLC32044I, TLC32045I	–40°C to 85°C
TLC32044M	–55°C to 125°C
Storage temperature range: TLC32044C, I, TLC32045C, I	–40°C to 125°C
TLC32044M	–65°C to 150°C
Case temperature for 10 seconds: FN or FK package	260°C
Lead temperature 1,6 mm (1/16 inch) from case for 10 seconds: N package	260°C
J package	300°C

† Stresses beyond those listed under “absolute maximum ratings” may cause permanent damage to the device. These are stress ratings only, and functional operation of the device at these or any other conditions beyond those indicated under “recommended operating conditions” is not implied. Exposure to absolute-maximum-rated conditions for extended periods may affect device reliability.

NOTE 1: Voltage values for maximum ratings are with respect to  $V_{CC-}$ .

### recommended operating conditions

	MIN	NOM	MAX	UNIT
Supply voltage, $V_{CC+}$ (see Note 2)	4.75	5	5.25	V
Supply voltage, $V_{CC-}$ (see Note 2)	–4.75	–5	–5.25	V
Digital supply voltage, $V_{DD}$ (see Note 2)	4.75	5	5.25	V
Digital ground voltage with respect to ANLG GND, DGTL GND		0		V
Reference input voltage, $V_{ref(ext)}$ (see Note 2)	2		4	V
High-level input voltage, $V_{IH}$	2		$V_{DD}+0.3$	V
Low-level input voltage, $V_{IL}$ (see Note 3)	–0.3		0.8	V
Load resistance at OUT+ and/or OUT–, $R_L$	300			$\Omega$
Load capacitance at OUT+ and/or OUT–, $C_L$			100	pF
MSTR CLK frequency (see Note 4)	0.075	5	10.368	MHz
Analog input amplifier common mode input voltage (see Note 5)			$\pm 1.5$	V
A/D or D/A conversion rate			20	kHz
Operating free-air temperature, $T_A$	TLC32044C, TLC32045C	0	70	°C
	TLC32044E	–20	85	
	TLC32044I, TLC32045I	–40	85	
	TLC32044M	–55	125	

NOTES: 2. Voltages at analog inputs and outputs, REF,  $V_{CC+}$ , and  $V_{CC-}$ , are with respect to the ANLG GND terminal. Voltages at digital inputs and outputs and  $V_{DD}$  are with respect to the DGTL GND terminal.

3. The algebraic convention, in which the least positive (most negative) value is designated minimum, is used in this data sheet for logic voltage levels and temperature only.

4. The bandpass switched-capacitor filter (SCF) specifications apply only when the low-pass section SCF clock is 288 kHz and the high-pass section SCF clock is 8 kHz. If the low-pass SCF clock is shifted from 288 kHz, the low-pass roll-off frequency will shift by the ratio of the low-pass SCF clock to 288 kHz. If the high-pass SCF is shifted from 8 kHz, the high-pass roll-off frequency will shift by the ratio of the high-pass SCF clock to 8 kHz. Similarly, the low-pass switched-capacitor filter (SCF) specifications apply only when the SCF clock is 288 kHz. If the SCF clock is shifted from 288 kHz, the low-pass roll-off frequency will shift by the ratio of the SCF clock to 288 kHz.

5. This range applies when (IN+ – IN–) or (AUX IN+ – AUX IN–) equals  $\pm 6$  V.



# TLC32044C, TLC32044E, TLC32044I, TLC32044M, TLC32045C, TLC32045I

## VOICE-BAND ANALOG INTERFACE CIRCUITS

SLAS017F – MARCH 1988 – REVISED MAY 1995

**electrical characteristics over recommended operating free-air temperature range,  $V_{CC+} = 5\text{ V}$ ,  $V_{CC-} = -5\text{ V}$ ,  $V_{DD} = 5\text{ V}$  (unless otherwise noted)**

**total device, MSTR CLK frequency = 5.184 MHz, outputs not loaded**

PARAMETER		TEST CONDITIONS	MIN	TYP†	MAX	UNIT
$V_{OH}$	High-level output voltage	$V_{DD} = 4.75\text{ V}$ , $I_{OH} = -300\text{ }\mu\text{A}$	2.4			V
$V_{OL}$	Low-level output voltage	$V_{DD} = 4.75\text{ V}$ , $I_{OL} = 2\text{ mA}$			0.4	
$I_{CC+}$	Supply current from $V_{CC+}$	TLC32044C, TLC32045C			35	mA
		TLC32044I, TLC32045I, TLC32044E, TLC32044M			40	
$I_{CC-}$	Supply current from $V_{CC-}$	TLC32044C, TLC32045C			-35	
		TLC32044I, TLC32045I, TLC32044E, TLC32044M			-40	
$I_{DD}$	Supply current from $V_{DD}$	TLC3204xC, E, I	$f_{MSTR\ CLK} = 5.184\text{ MHz}$		7	
		TLC32044M			8	
$V_{ref}$	Internal reference output voltage	TLC3204xC, E, I		3	3.3	V
		TLC32044M		2.9	3.3	
$\infty V_{ref}$	Temperature coefficient of internal reference voltage			200		ppm/°C
$r_o$	Output resistance at REF			100		k $\Omega$

### receive amplifier input

PARAMETER		TEST CONDITIONS	MIN	TYP†	MAX	UNIT
A/D converter offset error (filters in)		TLC32044C, E, I		10	70	mV
		TLC32044M		10	85	
		TLC32045C, I		10	75	
CMRR	Common-mode rejection ratio at $IN+$ , $IN-$ , or $AUX\ IN+$ , $AUX\ IN-$	TLC3204xC, E, I	See Note 6		55	dB
		TLC32044M			35	
$r_i$	Input resistance at $IN+$ , $IN-$ , or $AUX\ IN+$ , $AUX\ IN-$ , REF			100		k $\Omega$

### transmit filter output

PARAMETER		TEST CONDITIONS	MIN	TYP†	MAX	UNIT
$V_{OO}$	Output offset voltage at $OUT+$ $OUT-$ (single-ended relative to ANLG GND)	TLC3204xC, E, I		15	80	mV
		TLC32044M		15	75	
$V_{OM}$	Maximum peak output voltage swing across $R_L$ at $OUT+$ or $OUT-$ (single ended)	$R_L \geq 300\text{ }\Omega$ , Offset voltage = 0		$\pm 3$		V
$V_{OM}$	Maximum peak output voltage swing between $OUT+$ and $OUT-$ (differential output)	$R_L \geq 600\text{ }\Omega$		$\pm 6$		

† All typical values are at  $T_A = 25^\circ\text{C}$ .

NOTE 6: The test condition is a 0-dBm, 1-kHz input signal with an 8-kHz conversion rate.



# TLC32044C, TLC32044E, TLC32044I, TLC32044M, TLC32045C, TLC32045I

## VOICE-BAND ANALOG INTERFACE CIRCUITS

SLAS017F – MARCH 1988 – REVISED MAY 1995

### system distortion specifications, SCF clock frequency = 288 kHz (see Note 7)

PARAMETER			TEST CONDITIONS	MIN	TYP†	MAX	UNIT
Attenuation of second harmonic of A/D input signal	Single ended	TLC3204xC, E, I	$V_1 = -0.5 \text{ dB to } -24 \text{ dB}$ referred to $V_{ref}$ , $T_A = 25^\circ\text{C}$			70	dB
		TLC32044M		62	70		
	Differential	TLC32044C, E, I	$V_1 = -0.5 \text{ dB to } -24 \text{ dB}$ referred to $V_{ref}$	62	70		
		TLC32045C, I		55	70		
Attenuation of third and higher harmonics of A/D input signal	Single ended	TLC3204xC, E, I	$V_1 = -0.5 \text{ dB to } -24 \text{ dB}$ referred to $V_{ref}$ , $T_A = 25^\circ\text{C}$			65	
		TLC32044M		57	65		
	Differential	TLC32044C, E, I	$V_1 = -0.5 \text{ dB to } -24 \text{ dB}$ referred to $V_{ref}$	57	65		
		TLC32045C, I		55	65		
Attenuation of second harmonic of D/A input signal	Single ended	TLC3204xC, I, M	$V_1 = -0 \text{ dB to } -24 \text{ dB}$ referred to $V_{ref}$			70	
	Differential	TLC32044C, E, I		62	70		
		TLC32045C, I		55	70		
Attenuation of third and higher harmonics of D/A input signal	Single ended	TLC3204xC, I, M	$V_1 = -0 \text{ dB to } -24 \text{ dB}$ referred to $V_{ref}$			65	
	Differential	TLC32044C, E, I		57	65		
		TLC32045C, I		55	65		

† All typical values are at  $T_A = 25^\circ\text{C}$ .

NOTE 7: The test condition  $V_1$  is a 1-kHz input signal with an 8-kHz conversion rate (0 dB relative to  $V_{ref}$ ). The load impedance for the DAC is  $600 \Omega$  ( $300 \Omega$  for TLC32044M).



# TLC32044C, TLC32044E, TLC32044I, TLC32044M, TLC32045C, TLC32045I VOICE-BAND ANALOG INTERFACE CIRCUITS

SLAS017F – MARCH 1988 – REVISED MAY 1995

## A/D channel signal-to-distortion ratio (see Note 7)

PARAMETER	TEST CONDITIONS	$A_V = 1^\dagger$		$A_V = 2^\dagger$		$A_V = 4^\dagger$		UNIT
		MIN	MAX	MIN	MAX	MIN	MAX	
A/D channel signal-to-distortion ratio, TLC32044C, TLC32044I, TLC32044E	$V_I = -6 \text{ dB to } -0.1 \text{ dB}$	58		>58‡		>58‡		dB
	$V_I = -12 \text{ dB to } -6 \text{ dB}$	58		58		>58‡		
	$V_I = -18 \text{ dB to } -12 \text{ dB}$	56		58		58		
	$V_I = -24 \text{ dB to } -18 \text{ dB}$	50		56		58		
	$V_I = -30 \text{ dB to } -24 \text{ dB}$	44		50		56		
	$V_I = -36 \text{ dB to } -30 \text{ dB}$	38		44		50		
	$V_I = -42 \text{ dB to } -36 \text{ dB}$	32		38		44		
	$V_I = -48 \text{ dB to } -42 \text{ dB}$	26		32		38		
	$V_I = -54 \text{ dB to } -48 \text{ dB}$	20		26		32		
A/D channel signal-to-distortion ratio, TLC32044M	$V_I = -6 \text{ dB to } -0.5 \text{ dB}$	58		>58‡		>58‡		dB
	$V_I = -12 \text{ dB to } -6 \text{ dB}$	58		58		>58‡		
	$V_I = -18 \text{ dB to } -12 \text{ dB}$	56		58		58		
	$V_I = -24 \text{ dB to } -18 \text{ dB}$	50		56		58		
	$V_I = -30 \text{ dB to } -24 \text{ dB}$	44		50		56		
	$V_I = -36 \text{ dB to } -30 \text{ dB}$	38		44		50		
	$V_I = -42 \text{ dB to } -36 \text{ dB}$	32		38		44		
	$V_I = -48 \text{ dB to } -42 \text{ dB}$	26		32		38		
	$V_I = -54 \text{ dB to } -48 \text{ dB}$	20		26		32		
A/D channel signal-to-distortion ratio, TLC32045C, TLC32045I	$V_I = -6 \text{ dB to } -0.1 \text{ dB}$	55		>55‡		>55‡		dB
	$V_I = -12 \text{ dB to } -6 \text{ dB}$	55		55		>55‡		
	$V_I = -18 \text{ dB to } -12 \text{ dB}$	53		55		55		
	$V_I = -24 \text{ dB to } -18 \text{ dB}$	47		53		55		
	$V_I = -30 \text{ dB to } -24 \text{ dB}$	41		47		53		
	$V_I = -36 \text{ dB to } -30 \text{ dB}$	35		41		47		
	$V_I = -42 \text{ dB to } -36 \text{ dB}$	29		35		41		
	$V_I = -48 \text{ dB to } -42 \text{ dB}$	23		29		35		
	$V_I = -54 \text{ dB to } -48 \text{ dB}$	17		23		29		

†  $A_V$  is the programmable gain of the input amplifier.

‡ A value >60 is over range and signal clipping occurs.

NOTE 7: The test conditions are a 1-kHz input signal with an 8-kHz conversion rate (0 dB full-scale amplitude for the DAC is 600  $\Omega$  (300  $\Omega$  for TLC32044M)).



# TLC32044C, TLC32044E, TLC32044I, TLC32044M, TLC32045C, TLC32045I

## VOICE-BAND ANALOG INTERFACE CIRCUITS

SLAS017F – MARCH 1988 – REVISED MAY 1995

### D/A channel signal-to-distortion ratio (see Note 7)

PARAMETER	TEST CONDITIONS	MIN	MAX	UNIT
D/A channel signal-to-distortion ratio, TLC32044C, TLC32044E, TLC32044I, TLC32044M	$V_I = -6 \text{ dB to } 0 \text{ dB}$	58		dB
	$V_I = -12 \text{ dB to } -6 \text{ dB}$	58		
	$V_I = -18 \text{ dB to } -12 \text{ dB}$	56		
	$V_I = -24 \text{ dB to } -18 \text{ dB}$	50		
	$V_I = -30 \text{ dB to } -24 \text{ dB}$	44		
	$V_I = -36 \text{ dB to } -30 \text{ dB}$	38		
	$V_I = -42 \text{ dB to } -36 \text{ dB}$	32		
	$V_I = -48 \text{ dB to } -42 \text{ dB}$	26		
	$V_I = -54 \text{ dB to } -48 \text{ dB}$	20		
D/A channel signal-to-distortion ratio, TLC32045C, TLC32045I	$V_I = -6 \text{ dB to } 0 \text{ dB}$	55		
	$V_I = -12 \text{ dB to } -6 \text{ dB}$	55		
	$V_I = -18 \text{ dB to } -12 \text{ dB}$	53		
	$V_I = -24 \text{ dB to } -18 \text{ dB}$	47		
	$V_I = -30 \text{ dB to } -24 \text{ dB}$	41		
	$V_I = -36 \text{ dB to } -30 \text{ dB}$	35		
	$V_I = -42 \text{ dB to } -36 \text{ dB}$	29		
	$V_I = -48 \text{ dB to } -42 \text{ dB}$	23		
	$V_I = -54 \text{ dB to } -48 \text{ dB}$	17		

NOTE 7: The test condition  $V_I$  is a 1-kHz input signal with an 8-kHz conversion rate (0 dB relative to  $V_{ref}$ ). The load impedance for the DAC is 600  $\Omega$  (300  $\Omega$  for TLC32044M).

### gain and dynamic range

PARAMETER	TEST CONDITIONS	MIN	TYP†	MAX	UNIT
Absolute transmit gain tracking error while transmitting into 600 $\Omega$	-48-dB to 0-dB signal range, See Note 8		$\pm 0.05$	$\pm 0.15$	dB
Absolute transmit gain tracking error while transmitting into 300 $\Omega$ , TLC32044M	-48-dB to 0-dB signal range, $T_A = 25^\circ\text{C}$ , See Note 8		$\pm 0.05$	$\pm 0.25$	dB
Absolute transmit gain tracking error while transmitting into 300 $\Omega$ , TLC32044M	-48-dB to 0-dB signal range, $T_A = -55^\circ\text{C to } 125^\circ\text{C}$ , See Note 8			$\pm 0.4$	dB
Absolute receive gain tracking error	-48-dB to 0-dB signal range, See Note 8		$\pm 0.05$	$\pm 0.15$	dB
Absolute receive gain tracking error, TLC32044M	-48-dB to 0-dB signal range, $T_A = 25^\circ\text{C}$ , See Note 8		$\pm 0.05$	$\pm 0.25$	dB
Absolute receive gain tracking error, TLC32044M	-48-dB to 0-dB signal range, $T_A = -55^\circ\text{C to } 125^\circ\text{C}$ , See Note 8			$\pm 0.4$	dB
Absolute gain of the A/D channel	Signal input is a -0.5-dB, 1-kHz sinewave		0.2		dB
Absolute gain of the D/A channel	Signal input is a 0-dB, 1-kHz sinewave		-0.3		

† All typical values are at  $T_A = 25^\circ\text{C}$ .

NOTE 8: Gain tracking is relative to the absolute gain at 1 kHz and 0 dB (0 dB relative to  $V_{ref}$ ).



# TLC32044C, TLC32044E, TLC32044I, TLC32044M, TLC32045C, TLC32045I VOICE-BAND ANALOG INTERFACE CIRCUITS

SLAS017F – MARCH 1988 – REVISED MAY 1995

## power supply rejection and crosstalk attenuation

PARAMETER		TEST CONDITIONS	MIN	TYP†	MAX	UNIT
V <sub>CC+</sub> or V <sub>CC-</sub> supply voltage rejection ratio, receive channel	f = 0 to 30 kHz	Idle channel, supply signal at 200 mV p-p measured at DR (ADC output)			30	dB
	f = 30 kHz to 50 kHz				45	
V <sub>CC+</sub> or V <sub>CC-</sub> supply voltage rejection ratio, transmit channel (single ended)	f = 0 to 30 kHz	Idle channel, supply signal at 200 mV p-p measured at OUT+			30	
	f = 30 kHz to 50 kHz				45	
Crosstalk attenuation, transmit-to-receive (single ended)	TLC3204xC, E, I				80	
	TLC32044M		65	80		
Crosstalk attenuation, receive-to-transmit, TLC32044M		Inputs grounded, Gain = 1, 2, 4			65	

† All typical values are at T<sub>A</sub> = 25°C.

# TLC32044C, TLC32044E, TLC32044I, TLC32044M, TLC32045C, TLC32045I

## VOICE-BAND ANALOG INTERFACE CIRCUITS

SLAS017F – MARCH 1988 – REVISED MAY 1995

### delay distortion

bandpass filter transfer function, SCF  $f_{\text{clock}} = 288 \text{ kHz}$   $IN+ - IN-$  is a  $\pm 3 \text{ V}$  sinewave† (see Note 9)

PARAMETER	TEST CONDITIONS	FREQUENCY RANGE	ADJUSTMENT ADDEND‡	MIN	TYP§	MAX	UNIT
Filter gain, TLC32044C, TLC32044E, TLC32044I	Input signal reference to 0 dB	$f \leq 50 \text{ Hz}$	$K1 \times 0 \text{ dB}$	-33	-29	-25	dB
		$f = 100 \text{ Hz}$	$K1 \times -0.26 \text{ dB}$	-4	-2	-1	
		$f = 150 \text{ Hz to } 3100 \text{ Hz}$	$K1 \times 0 \text{ dB}$	-0.25	0	0.25	
		$f = 3100 \text{ Hz to } 3300 \text{ Hz}$	$K1 \times 0 \text{ dB}$	-0.3	0	0.3	
		$f = 3300 \text{ Hz to } 3650 \text{ Hz}$	$K1 \times 0 \text{ dB}$	-0.5	0	0.5	
		$f = 3800 \text{ Hz}$	$K1 \times 2.3 \text{ dB}$		-3	-1	
		$f = 4000 \text{ Hz}$	$K1 \times 2.7 \text{ dB}$		-17	-16	
		$f \geq 4400 \text{ Hz}$	$K1 \times 3.2 \text{ dB}$			-40	
		$f \geq 5000 \text{ Hz}$	$K1 \times 0 \text{ dB}$			-65	
Filter gain, TLC32044M	Input signal reference to 0 dB	$f \leq 50 \text{ Hz}$	$K1 \times 0 \text{ dB}$	-33	-29	-25	dB
		$f = 100 \text{ Hz}$	$K1 \times -0.26 \text{ dB}$	-4	-2	-1	
		$f = 150 \text{ Hz to } 3100 \text{ Hz}$	$K1 \times 0 \text{ dB}$	-0.25	0	0.25	
		$f = 3100 \text{ Hz to } 3300 \text{ Hz}$	$K1 \times 0 \text{ dB}$	-0.3	0	0.3	
		$f = 3300 \text{ Hz to } 3500 \text{ Hz}$	$K1 \times 0 \text{ dB}$	-0.5	0	0.5	
		$f = 3800 \text{ Hz}$	$K1 \times 2.3 \text{ dB}$		-3	-0.5	
		$f = 4000 \text{ Hz}$	$K1 \times 2.7 \text{ dB}$		-17	-16	
		$f \geq 4400 \text{ Hz}$	$K1 \times 3.2 \text{ dB}$			-40	
		$f \geq 5000 \text{ Hz}$	$K1 \times 0 \text{ dB}$			-65	
Filter gain, TLC32045C, TLC32045I	Input signal reference to 0 dB	$f \leq 50 \text{ Hz}$	$K1 \times 0 \text{ dB}$	-33	-29	-25	dB
		$f = 100 \text{ Hz}$	$K1 \times -0.26 \text{ dB}$	-4	-2	-1	
		$f = 150 \text{ Hz to } 3100 \text{ Hz}$	$K1 \times 0 \text{ dB}$	-0.25	0	0.25	
		$f = 3100 \text{ Hz to } 3300 \text{ Hz}$	$K1 \times 0 \text{ dB}$	-0.3	0	0.3	
		$f = 3300 \text{ Hz to } 3650 \text{ Hz}$	$K1 \times 0 \text{ dB}$	-0.5	0	0.5	
		$f = 3800 \text{ Hz}$	$K1 \times 2.3 \text{ dB}$		-3	-1	
		$f = 4000 \text{ Hz}$	$K1 \times 2.7 \text{ dB}$		-17	-16	
		$f \geq 4400 \text{ Hz}$	$K1 \times 3.2 \text{ dB}$			-40	
		$f \geq 5000 \text{ Hz}$	$K1 \times 0 \text{ dB}$			-65	

† See filter curves in typical characteristics

‡ The MIN, TYP, and MAX specifications are given for a 288-kHz SCF clock frequency. A slight error in the 288-kHz SCF may result from inaccuracies in the MSTR CLK frequency, resulting from crystal frequency tolerances. If this frequency error is less than 0.25%, the ADJUSTMENT ADDEND should be added to the MIN, TYP, and MAX specifications, where  $K1 = 100 \cdot [(SCF \text{ frequency} - 288 \text{ kHz}) / 288 \text{ kHz}]$ . For errors greater than 0.25%, see Note 8.

§ All typical values are at  $T_A = 25^\circ\text{C}$ .

NOTE 9: The filter gain outside of the passband is measured with respect to the gain at 1 kHz. The filter gain within the passband is measured with respect to the average gain within the passband. The passbands are 150 to 3600 Hz and 0 to 3600 Hz for the bandpass and low-pass filters respectively. For switched-capacitor filter clocks at frequencies other than 288 kHz, the filter response is shifted by the ratio of switched-capacitor filter clock frequency to 288 kHz.





# TLC32044C, TLC32044E, TLC32044I, TLC32044M, TLC32045C, TLC32045I VOICE-BAND ANALOG INTERFACE CIRCUITS

SLAS017F – MARCH 1988 – REVISED MAY 1995

## low-pass filter transfer function†, SCF $f_{\text{clock}} = 288 \text{ kHz}$ (see Note 9)

PARAMETER	TEST CONDITIONS	FREQUENCY RANGE	ADJUSTMENT ADDEND‡	MIN	TYP§	MAX	UNIT
Filter gain, TLC32044C, TLC32044E, TLC32044I	Input signal reference is 0 dB	f = 0 Hz to 3100 Hz	$K1 \times 0 \text{ dB}$	-0.25	0	0.25	dB
		f = 3100 Hz to 3300 Hz	$K1 \times 0 \text{ dB}$	-0.3	0	0.3	
		f = 3300 Hz to 3650 Hz	$K1 \times 0 \text{ dB}$	-0.5	0	0.5	
		f = 3800 Hz	$K1 \times 2.3 \text{ dB}$		-3	-1	
		f = 4000 Hz	$K1 \times 2.7 \text{ dB}$		-17	-16	
		f ≥ 4400 Hz	$K1 \times 3.2 \text{ dB}$			-40	
		f ≥ 5000 Hz	$K1 \times 0 \text{ dB}$			-65	
Filter gain, TLC32044M	Input signal reference is 0 dB	f = 0 Hz to 3100 Hz	$K1 \times 0 \text{ dB}$	-0.25	0	0.25	dB
		f = 3100 Hz to 3300 Hz	$K1 \times 0 \text{ dB}$	-0.3	0	0.3	
		f = 3300 Hz to 3500 Hz	$K1 \times 0 \text{ dB}$	-0.5	0	0.5	
		f = 3800 Hz	$K1 \times 2.3 \text{ dB}$		-3	-0.5	
		f = 4000 Hz	$K1 \times 2.7 \text{ dB}$		-17	-16	
		f ≥ 4400 Hz	$K1 \times 3.2 \text{ dB}$			-40	
		f ≥ 5000 Hz	$K1 \times 0 \text{ dB}$			-65	
Filter gain, TLC32045C, TLC32045I	Input signal reference is 0 dB	f = 0 Hz to 3100 Hz	$K1 \times 0 \text{ dB}$	-0.25	0	0.25	dB
		f = 3100 Hz to 3300 Hz	$K1 \times 0 \text{ dB}$	-0.3	0	0.3	
		f = 3300 Hz to 3650 Hz	$K1 \times 0 \text{ dB}$	-0.5	0	0.5	
		f = 3800 Hz	$K1 \times 2.3 \text{ dB}$		-3	-1	
		f = 4000 Hz	$K1 \times 2.7 \text{ dB}$		-17	-16	
		f ≥ 4400 Hz	$K1 \times 3.2 \text{ dB}$			-40	
		f ≥ 5000 Hz	$K1 \times 0 \text{ dB}$			-65	

† See filter curves in typical characteristics

‡ The MIN, TYP, and MAX specifications are given for a 288-kHz SCF clock frequency. A slight error in the 288-kHz SCF may result from inaccuracies in the MSTR CLK frequency, resulting from crystal frequency tolerances. If this frequency error is less than 0.25%, the ADJUSTMENT ADDEND should be added to the MIN, TYP, and MAX specifications, where  $K1 = 100 \cdot [(SCF \text{ frequency} - 288 \text{ kHz}) / 288 \text{ kHz}]$ . For errors greater than 0.25%, see Note 8.

§ All typical values are at  $T_A = 25^\circ\text{C}$ .

NOTE 9: The filter gain outside of the passband is measured with respect to the gain at 1 kHz. The filter gain within the passband is measured with respect to the average gain within the passband. The passbands are 150 to 3600 Hz and 0 to 3600 Hz for the bandpass and low-pass filters respectively. For switched-capacitor filter clocks at frequencies other than 288 kHz, the filter response is shifted by the ratio of switched-capacitor filter clock frequency to 288 kHz.

## serial port

PARAMETER	TEST CONDITIONS	MIN	TYP†	MAX	UNIT
$V_{OH}$ High-level output voltage	$I_{OH} = -300 \mu\text{A}$	2.4			V
$V_{OL}$ Low-level output voltage	$I_{OL} = 2 \text{ mA}$			0.4	V
$I_I$ Input current				±10	$\mu\text{A}$
$C_i$ Input capacitance			15		pF
$C_o$ Output capacitance			15		pF

† All typical values are at  $T_A = 25^\circ\text{C}$ .



# TLC32044C, TLC32044E, TLC32044I, TLC32044M, TLC32045C, TLC32045I

## VOICE-BAND ANALOG INTERFACE CIRCUITS

SLAS017F – MARCH 1988 – REVISED MAY 1995

operating characteristics over recommended operating free-air temperature range,  $V_{CC+} = 5\text{ V}$ ,  $V_{CC-} = -5\text{ V}$ ,  $V_{DD} = 5\text{ V}$

noise (measurement includes low-pass and bandpass switched-capacitor filters)

PARAMETER		TEST CONDITIONS	MIN	TYP†	MAX	UNIT	
Transmit noise	TLC32044C, E, I	With sin x/x correction			550	$\mu\text{V rms}$	
	TLC32044M				575	$\mu\text{V rms}$	
	TLC32045C, I				600	$\mu\text{V rms}$	
	TLC32044C, E, I	Without sin x/x correction	DX input = 00000000000000, constant input code		325	425	$\mu\text{V rms}$
	TLC32044M				325	450	$\mu\text{V rms}$
	TLC32045C, I				450		$\mu\text{V rms}$
	TLC32044C, E, I				18		dBrncO
	TLC32045C, I				24		dBrncO
Receive noise (see Note 10)	TLC32044C, E, I, M	Inputs grounded, gain = 1			300	500	$\mu\text{V rms}$
	TLC32045C, I				530		$\mu\text{V rms}$
	TLC32044C, E, I, M				18		dBrncO
	TLC32045C, I			24		dBrncO	

† All typical values are at  $T_A = 25^\circ\text{C}$ .

NOTE 10: The noise is computed by statistically evaluating the digital output of the A/D converter.

### timing requirements

#### serial port recommended input signals

		MIN	MAX	UNIT
$t_c(\text{MCLK})$	Master clock cycle time	95		ns
	Master clock cycle time, TLC32044M	100	192	ns
$t_r(\text{MCLK})$	Master clock rise time		10	ns
$t_f(\text{MCLK})$	Master clock fall time		10	ns
	Master clock duty cycle	25%	75%	
	Master clock duty cycle, TLC32044M	42%	58%	
	$\overline{\text{RESET}}$ pulse duration (see Note 11)	800		ns
$t_{su}(\text{DX})$	DX setup time before SCLK↓	20		ns
	DX setup time before SCLK↓, TLC32044M	28		ns
$t_h(\text{DX})$	DX hold time after SCLK↓	$t_c(\text{SCLK})/4$		ns

NOTE 11:  $\overline{\text{RESET}}$  pulse duration is the amount of time that the reset pin is held below 0.8 V after the power supplies have reached their recommended values.



# TLC32044C, TLC32044E, TLC32044I, TLC32044M, TLC32045C, TLC32045I VOICE-BAND ANALOG INTERFACE CIRCUITS

SLAS017F – MARCH 1988 – REVISED MAY 1995

## serial port — AIC output signals

	TEST CONDITIONS	MIN	TYP†	MAX	UNIT
$t_c(\text{SCLK})$ Shift clock (SCLK) cycle time		380			ns
$t_f(\text{SCLK})$ Shift clock (SCLK) fall time			50		ns
$t_r(\text{SCLK})$ Shift clock (SCLK) rise time			50		ns
Shift clock (SCLK) duty cycle		45		55	%
$t_d(\text{CH-FL})$ Delay from SCLK↑ to $\overline{\text{FSR}}/\overline{\text{FSX}}\downarrow$	$C_L = 50$ pF			52	ns
$t_d(\text{CH-FH})$ Delay from SCLK↑ to $\overline{\text{FSR}}/\overline{\text{FSX}}\uparrow$	$C_L = 50$ pF			52	ns
$t_d(\text{CH-DR})$ DR valid after SCLK↑				90	ns
$t_d(\text{CH-EL})$ Delay from SCLK↑ to $\overline{\text{EODX}}/\overline{\text{EODR}}\downarrow$ in word mode				90	ns
$t_d(\text{CH-EH})$ Delay from SCLK↑ to $\overline{\text{EODX}}/\overline{\text{EODR}}\uparrow$ in word mode				90	ns
$t_f(\text{EODX})$ $\overline{\text{EODX}}$ fall time				15	ns
$t_f(\text{EODR})$ $\overline{\text{EODR}}$ fall time				15	ns
$t_d(\text{CH-EL})$ Delay from SCLK↑ to $\overline{\text{EODX}}/\overline{\text{EODR}}\downarrow$ in byte mode				100	ns
$t_d(\text{CH-EH})$ Delay from SCLK↑ to $\overline{\text{EODX}}/\overline{\text{EODR}}\uparrow$ in byte mode				100	ns
$t_d(\text{MH-SL})$ Delay from MSTR CLK↑ to SCLK↓			65		ns
$t_d(\text{MH-SH})$ Delay from MSTR CLK↑ to SCLK↑			65		ns

## serial port — AIC output signals, TLC32044M

	MIN	TYP†	MAX	UNIT
$t_c(\text{SCLK})$ Shift clock (SCLK) cycle time	400			ns
$t_f(\text{SCLK})$ Shift clock (SCLK) fall time		50		ns
$t_r(\text{SCLK})$ Shift clock (SCLK) rise time		50		ns
Shift clock (SCLK) duty cycle		50		%
$t_d(\text{CH-FL})$ Delay from SCLK↑ to $\overline{\text{FSR}}/\overline{\text{FSX}}\downarrow$			260	ns
$t_d(\text{CH-FH})$ Delay from SCLK↑ to $\overline{\text{FSR}}/\overline{\text{FSX}}\uparrow$			260	ns
$t_d(\text{CH-DR})$ DR valid after SCLK↑			316	ns
$t_d(\text{CH-EL})$ Delay from SCLK↑ to $\overline{\text{EODX}}/\overline{\text{EODR}}\downarrow$ in word mode			280	ns
$t_d(\text{CH-EH})$ Delay from SCLK↑ to $\overline{\text{EODX}}/\overline{\text{EODR}}\uparrow$ in word mode			280	ns
$t_f(\text{EODX})$ $\overline{\text{EODX}}$ fall time		15		ns
$t_f(\text{EODR})$ $\overline{\text{EODR}}$ fall time		15		ns
$t_d(\text{CH-EL})$ Delay from SCLK↑ to $\overline{\text{EODX}}/\overline{\text{EODR}}\downarrow$ in byte mode		100		ns
$t_d(\text{CH-EH})$ Delay from SCLK↑ to $\overline{\text{EODX}}/\overline{\text{EODR}}\uparrow$ in byte mode		100		ns
$t_d(\text{MH-SL})$ Delay from MSTR CLK↑ to SCLK↓		65		ns
$t_d(\text{MH-SH})$ Delay from MSTR CLK↑ to SCLK↑		65		ns

† Typical values are at  $T_A = 25^\circ\text{C}$ .



# TLC32044C, TLC32044E, TLC32044I, TLC32044M, TLC32045C, TLC32045I VOICE-BAND ANALOG INTERFACE CIRCUITS

SLAS017F – MARCH 1988 – REVISED MAY 1995

**Table 3. Gain Control Table (Analog Input Signal Required for Full-Scale A/D Conversion)**

INPUT CONFIGURATIONS	CONTROL REGISTER BITS		ANALOG INPUT‡	A/D CONVERSION RESULT
	d6	d7		
Differential configuration Analog input = IN+ – IN– = AUX IN+ – AUX IN–	1	1	±6 V	Full-scale
	0	0		
	1	0	±3 V	Full-scale
	0	1	±1.5 V	Full-scale
Single-ended configuration Analog input = IN+ – ANLG GND = AUX IN+ – ANLG GND	1	1	±3 V	Half-scale
	0	0		
	1	0	±3 V	Full-scale
	0	1	±1.5 V	Full-scale

‡ In this example,  $V_{ref}$  is assumed to be 3 V. In order to minimize distortion, it is recommended that the analog input not exceed 0.1 dB below full scale.

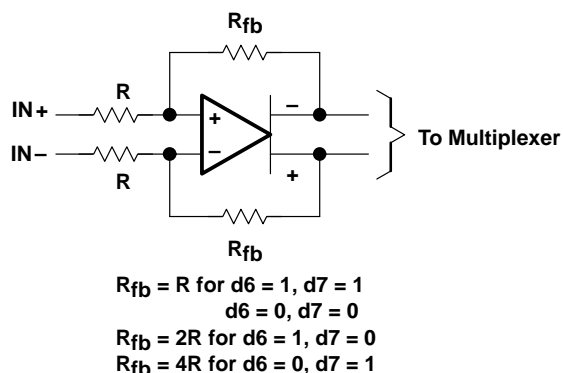

**Figure 7. IN+ and IN– Gain Control Circuitry**

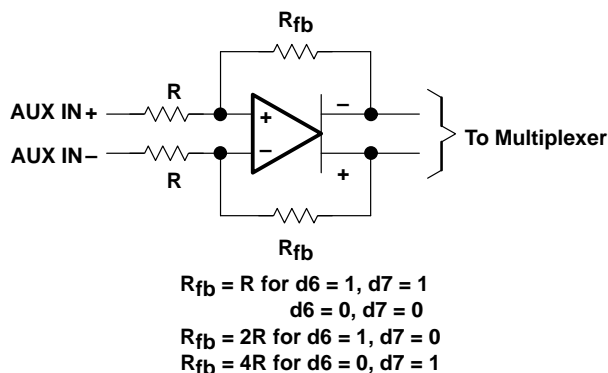

**Figure 8. AUX IN+ and AUX IN– Gain Control Circuitry**

## (sin x)/x correction

The AIC does not have (sin x)/x correction circuitry after the digital-to-analog converter. (Sin x)/x correction can be accomplished easily and efficiently in digital signal processor (DSP) software. Excellent correction accuracy can be achieved to a band edge of 3000 Hz by using a first-order digital correction filter. The results, which are shown in Table 4, are typical of the numerical correction accuracy that can be achieved for sample rates of interest. The filter requires only seven instruction cycles per sample on the TMS(SMJ)320 DSPs. With a 200-ns instruction cycle, nine instructions per sample represents an overhead factor of 1.4% and 1.7% for sampling rates of 8000 Hz and 9600 Hz, respectively. This correction adds a slight amount of group delay at the upper edge of the 300–3000-Hz band.

**(sin x)/x roll-off for a zero-order hold function**

The (sin x)/x roll-off for the AIC DAC zero-order hold function at a band-edge frequency of 3000 Hz for the various sampling rates is shown in the table below.

**Table 4. (sin x)/x Roll-Off**

$f_s$ (Hz)	$20 \log \frac{\sin \pi f/f_s}{\pi f/f_s}$ ( $f = 3000$ Hz) (dB)
7200	-2.64
8000	-2.11
9600	-1.44
14400	-0.63
19200	-0.35

The actual AIC (sin x)/x roll-off will be slightly less than the above figures because the AIC has less than a 100% duty cycle hold interval.

**correction filter**

To compensate for the (sin x)/x roll-off of the AIC, a first-order correction filter (shown below) is recommended.

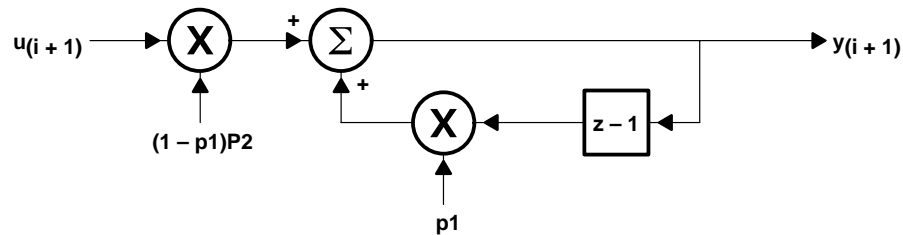

The difference equation for this correction filter is:

$$y_i + 1 = p_2(1 - p_1) (u_i + 1) + p_1 y_i$$

where the constant p1 determines the pole locations.

The resulting squared magnitude transfer function is:

$$|H(f)|^2 = \frac{p_2^2 (1-p_1)^2}{1 - 2p_1 \cos(2 \pi f/f_s) + p_1^2}$$

# TLC32044C, TLC32044E, TLC32044I, TLC32044M, TLC32045C, TLC32045I VOICE-BAND ANALOG INTERFACE CIRCUITS

SLAS017F – MARCH 1988 – REVISED MAY 1995

## correction results

Table 5 shows the optimum p values and the corresponding correction results for 8000-Hz and 9600-Hz sampling rates.

**Table 5. Optimum P Values**

f (Hz)	ERROR (dB) f <sub>s</sub> = 8000 Hz p1 = -0.14813 p2 = 0.9888	ERROR (dB) f <sub>s</sub> = 9600 Hz p1 = -0.1307 p2 = 0.9951
300	-0.099	-0.043
600	-0.089	-0.043
900	-0.054	0
1200	-0.002	0
1500	0.041	0
1800	0.079	0.043
2100	0.100	0.043
2400	0.091	0.043
2700	-0.043	0
3000	-0.102	-0.043

## TMS(SMJ)320 software requirements

The digital correction filter equation can be written in state variable form as follows:

$$Y = k1 \times Y + k2 \times U$$

where

$$k1 = p1$$

$$k2 = (1 - p1) \times p2$$

Y = filter state

U = next I/O sample

The coefficients k1 and k2 must be represented as 16-bit integers. The SACH instruction (with the proper shift) yields the correct result. With the assumption that the TMS(SMJ)320 processor page pointer and memory configuration are properly initialized, the equation can be executed in seven instructions or seven cycles with the following program:

```
ZAC
LT K2
MPY U
LTA K1
MPY Y
APAC
SACH (dma), (shift)
```

PARAMETER MEASUREMENT INFORMATION

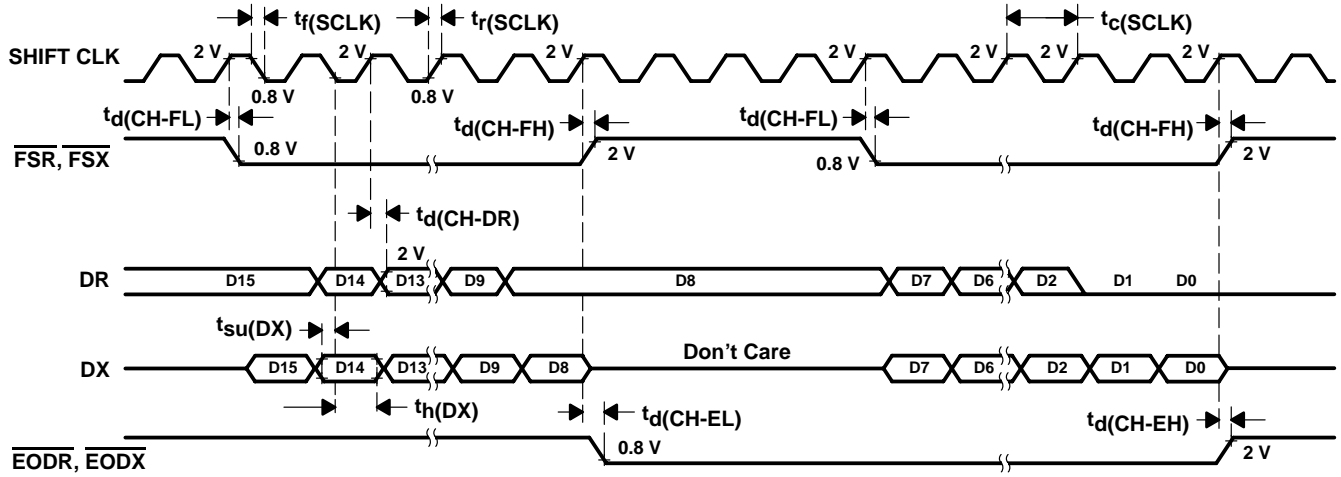

(a) BYTE-MODE TIMING

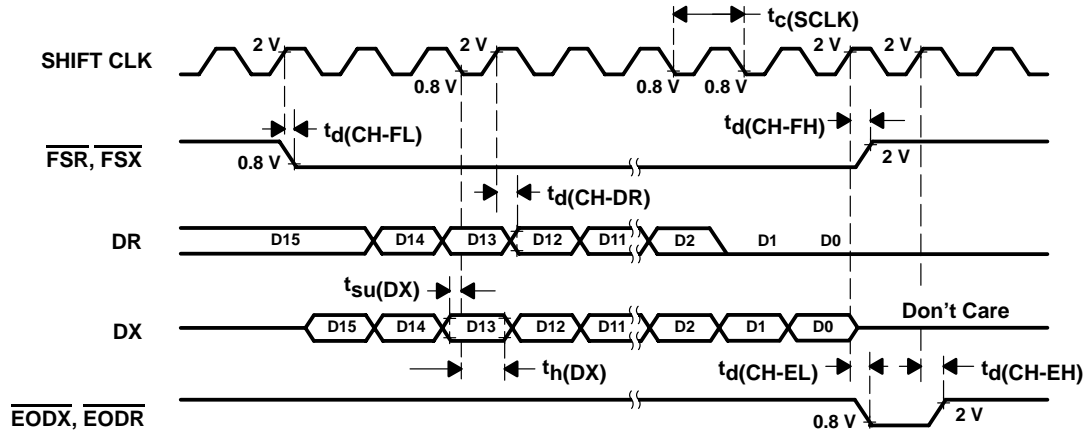

(b) WORD-MODE TIMING

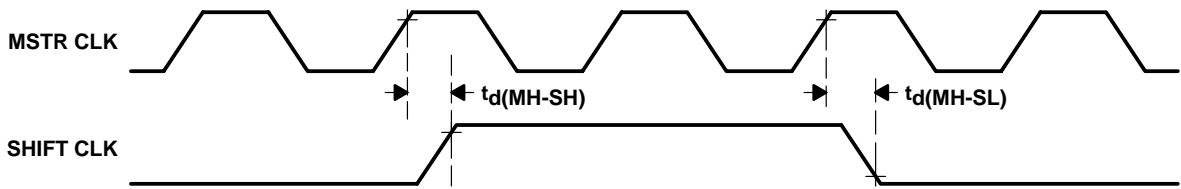

(c) SHIFT-CLOCK TIMING

Figure 9. Serial-Port Timing

# TLC32044C, TLC32044E, TLC32044I, TLC32044M, TLC32045C, TLC32045I VOICE-BAND ANALOG INTERFACE CIRCUITS

SLAS017F – MARCH 1988 – REVISED MAY 1995

## PARAMETER MEASUREMENT INFORMATION

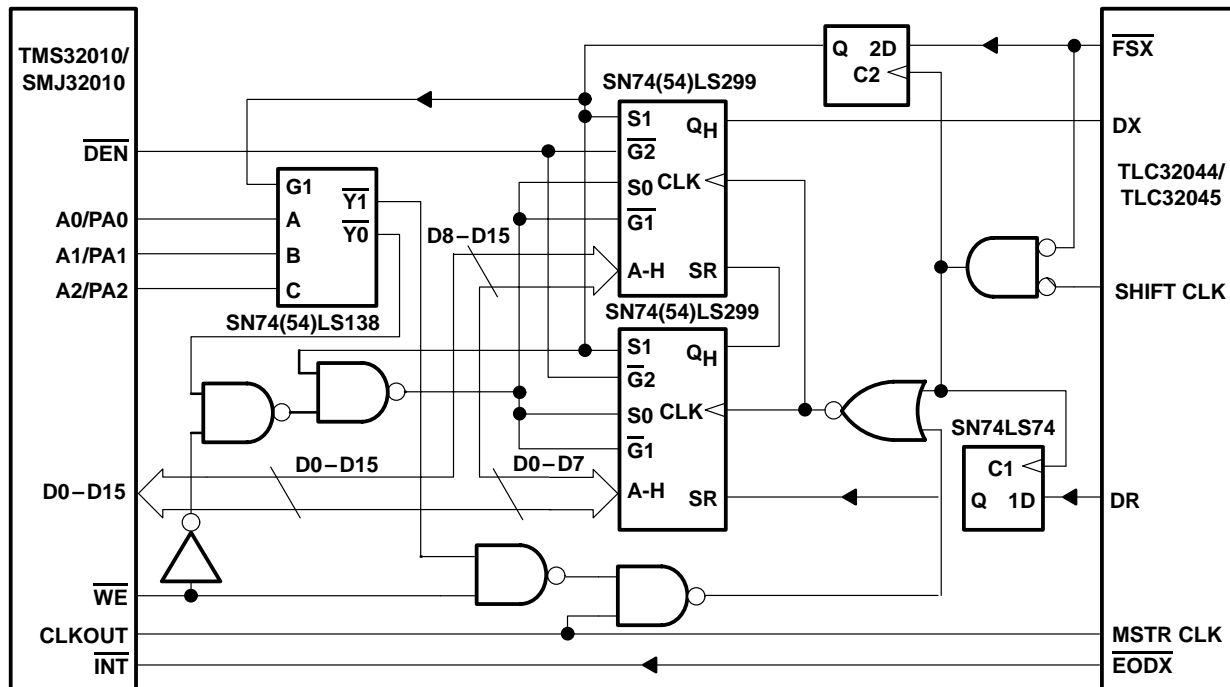

Figure 10. TMS(SMJ)32010/TMS(SMJ)320C15/(SMJ320E15)-TLC32044/45 Interface Circuit



PARAMETER MEASUREMENT INFORMATION

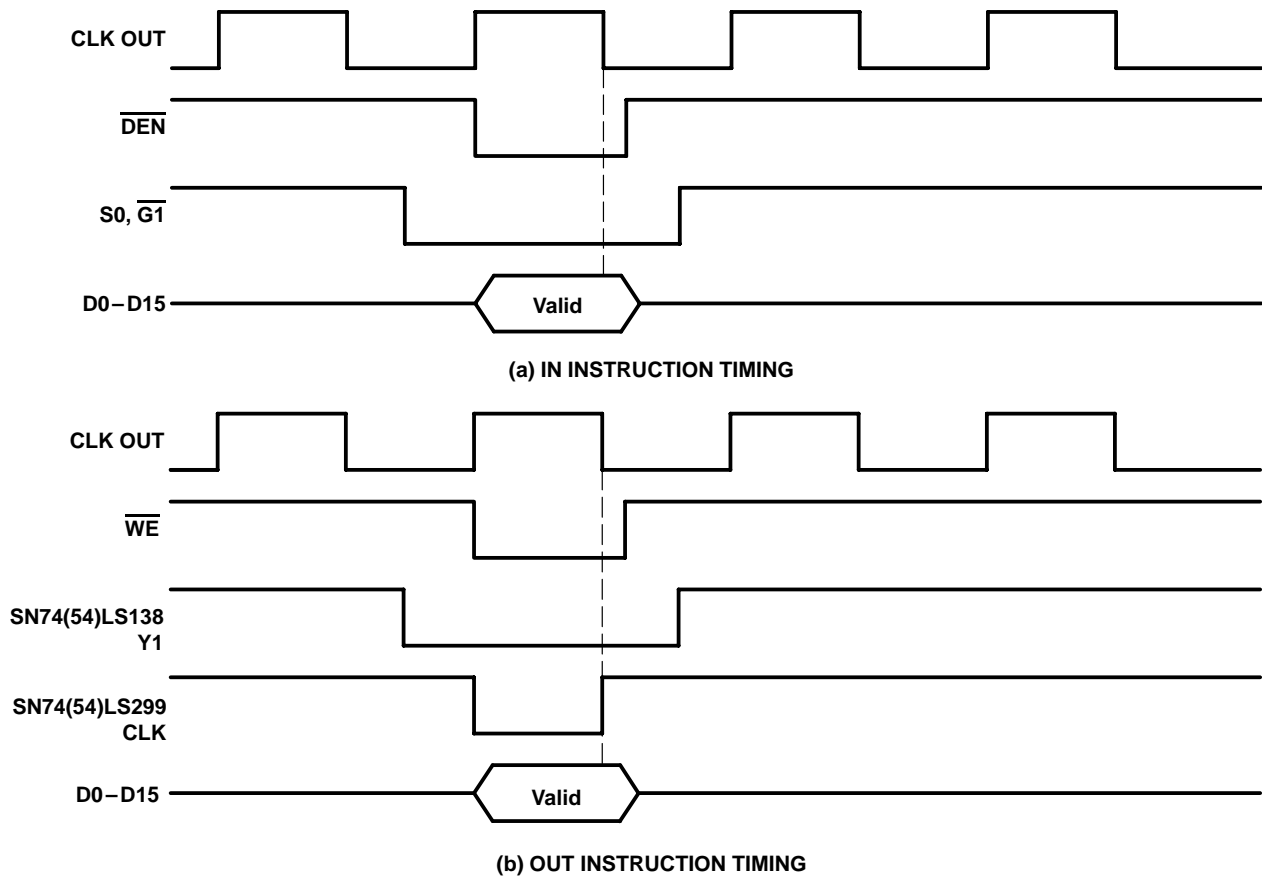

Figure 11. TMS(SMJ)32010/TMS(SMJ)320C15-TLC32044/TLC32045 Interface Timing

# TLC32044C, TLC32044E, TLC32044I, TLC32044M, TLC32045C, TLC32045I VOICE-BAND ANALOG INTERFACE CIRCUITS

SLAS017F – MARCH 1988 – REVISED MAY 1995

## TYPICAL CHARACTERISTICS

**AIC TRANSMIT AND RECEIVE  
LOW-PASS FILTER**

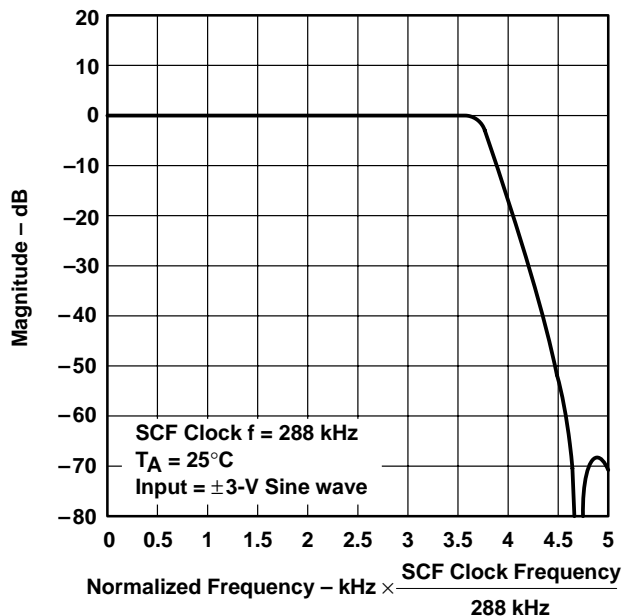

Figure 12

**AIC TRANSMIT AND RECEIVE  
LOW-PASS FILTER**

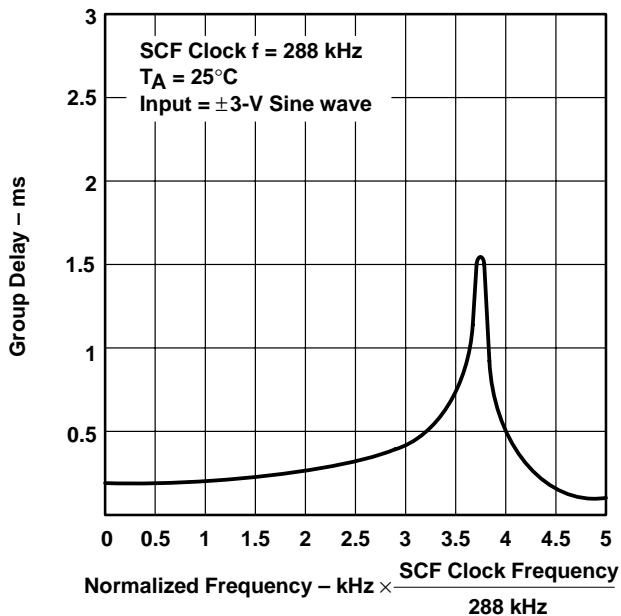

Figure 13

**AIC RECEIVE-CHANNEL  
BANDPASS FILTER**

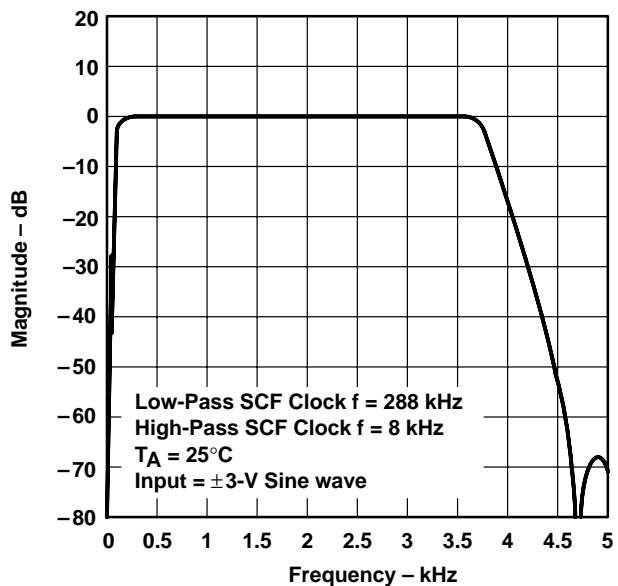

Figure 14

**AIC RECEIVE-CHANNEL  
HIGH-PASS FILTER**

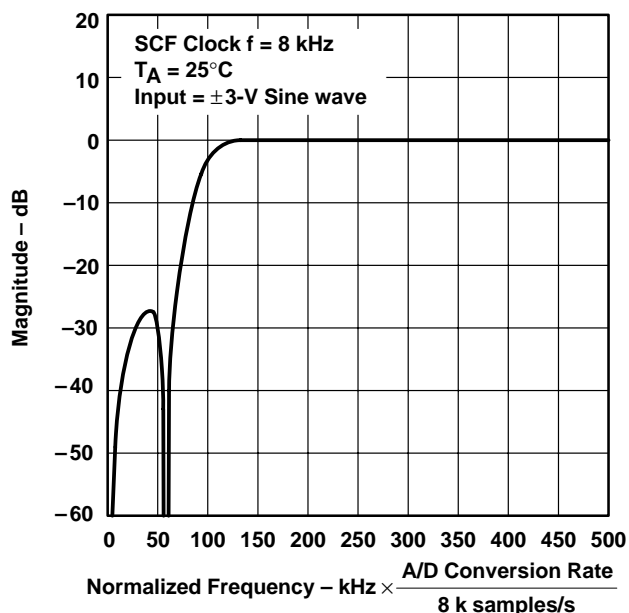
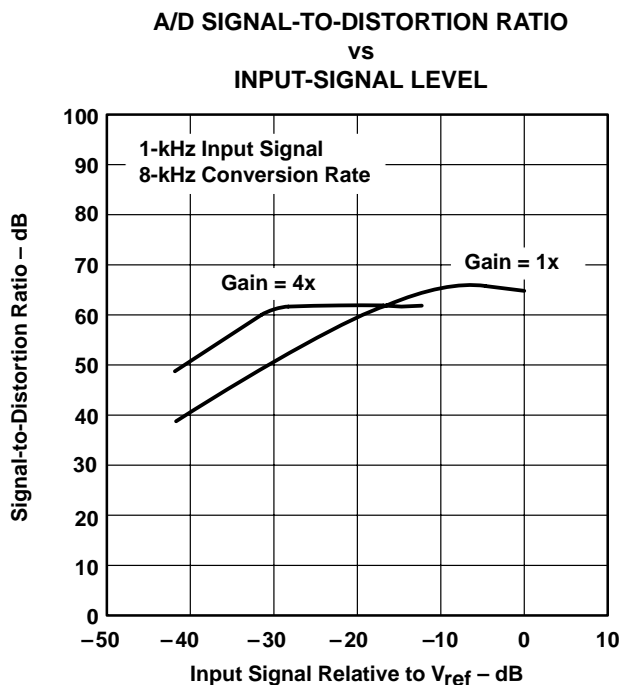
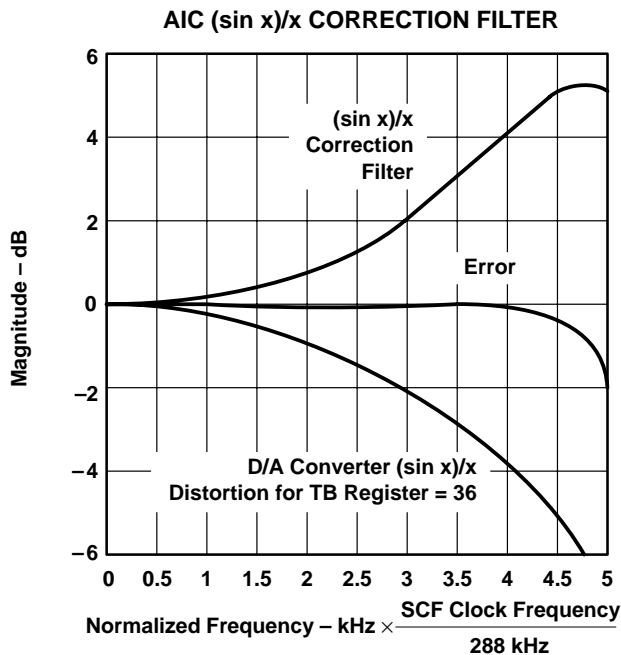
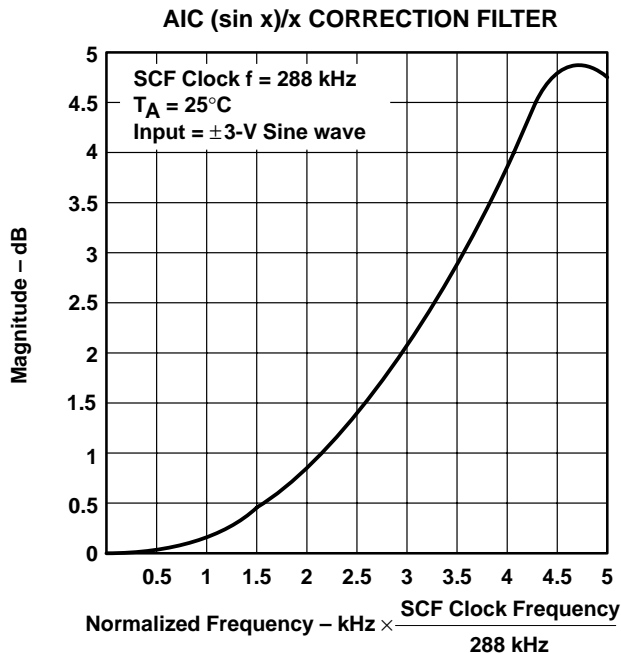
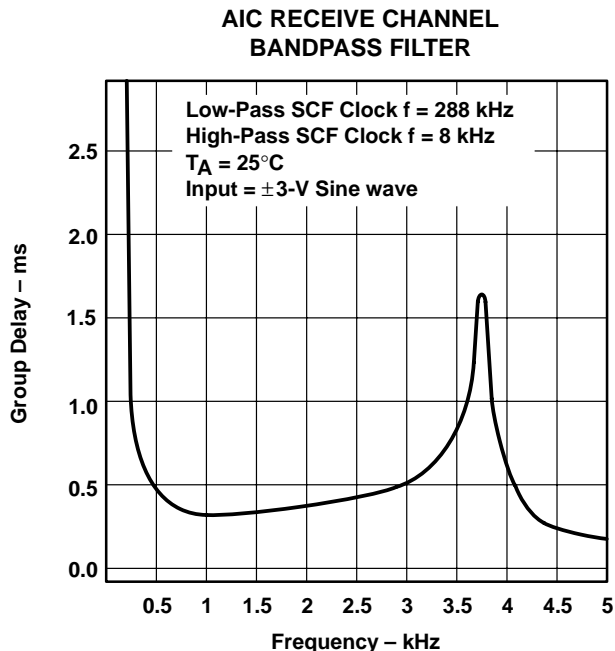

Figure 15

TYPICAL CHARACTERISTICS



TYPICAL CHARACTERISTICS

A/D GAIN TRACKING  
 (GAIN RELATIVE TO GAIN  
 AT 0-dB INPUT-SIGNAL LEVEL)

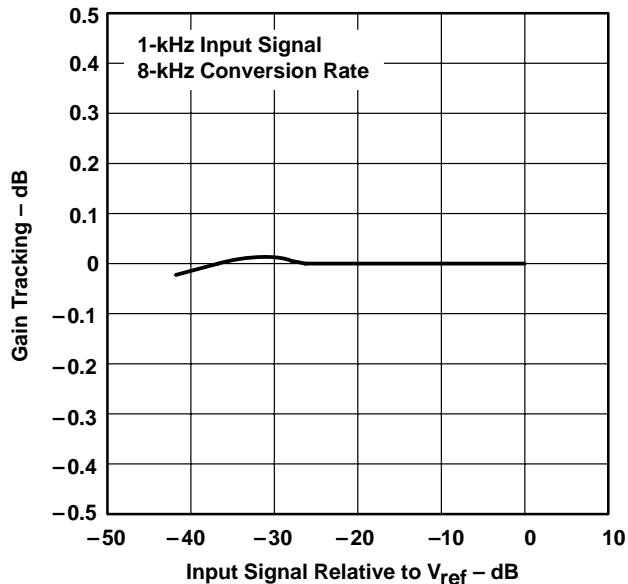

Figure 20

D/A CONVERTER SIGNAL-TO-DISTORTION RATIO  
 vs  
 INPUT-SIGNAL LEVEL

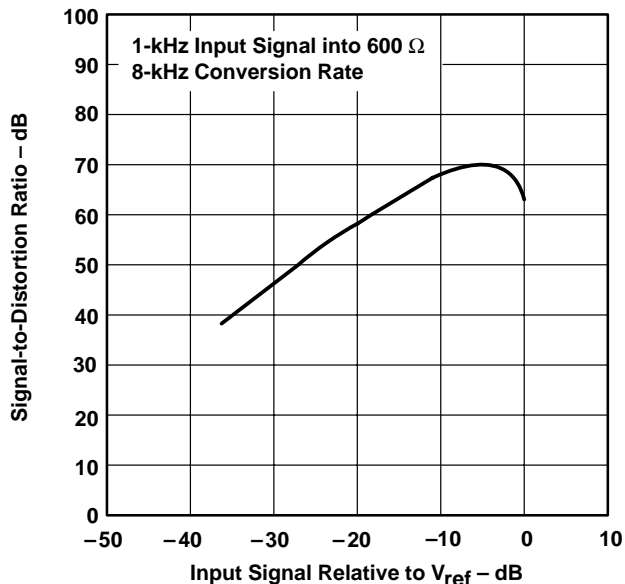

Figure 21

D/A GAIN TRACKING  
 (GAIN RELATIVE TO GAIN  
 AT 0-dB INPUT-SIGNAL LEVEL)

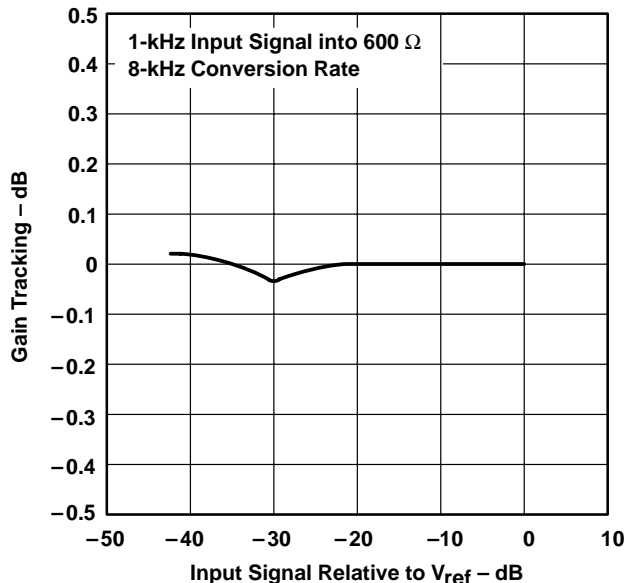

Figure 22

A/D SECOND HARMONIC DISTORTION  
 vs  
 INPUT-SIGNAL LEVEL

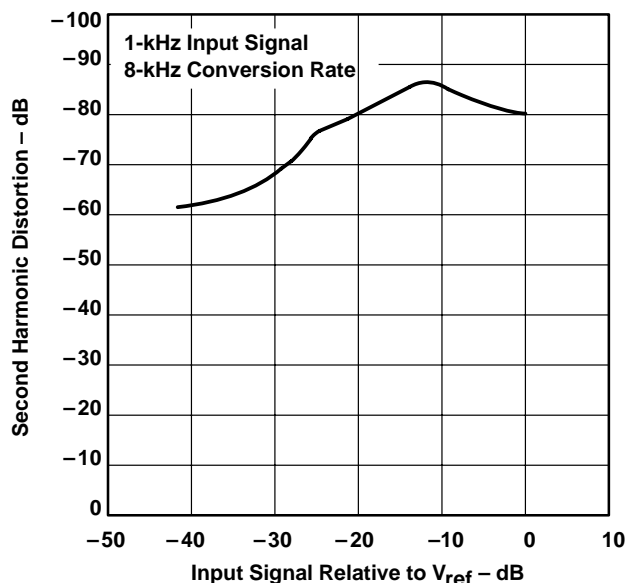

Figure 23

TYPICAL CHARACTERISTICS

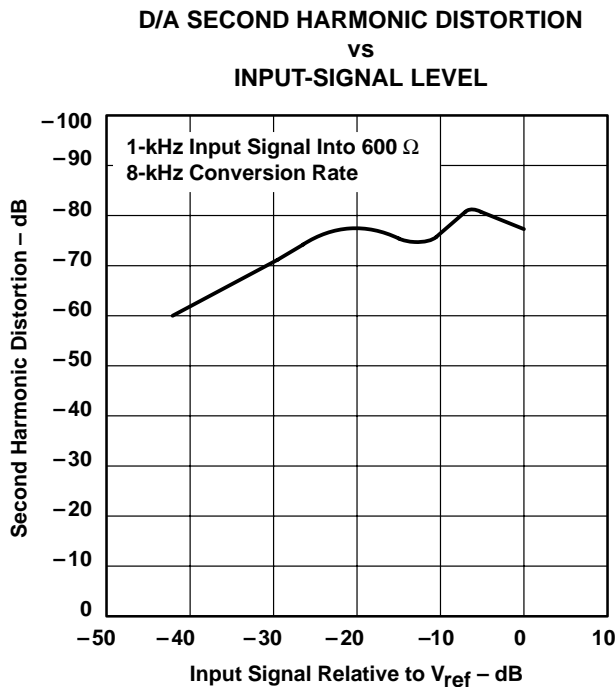

Figure 24

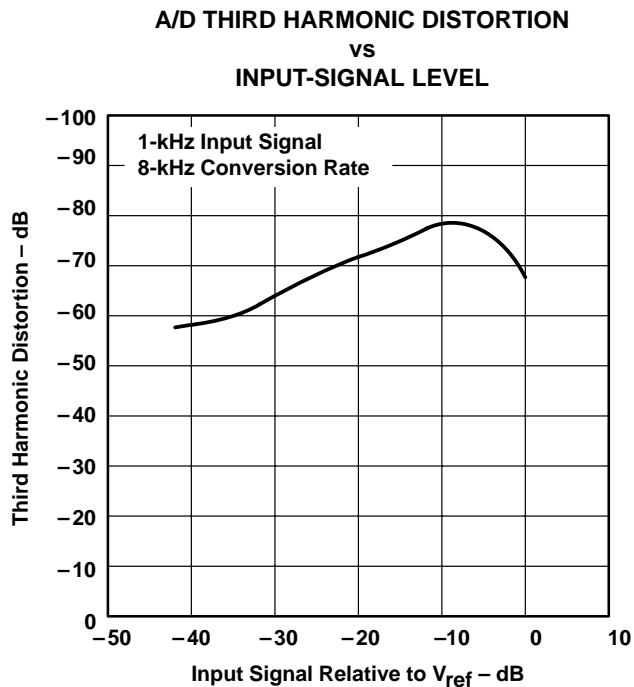

Figure 25

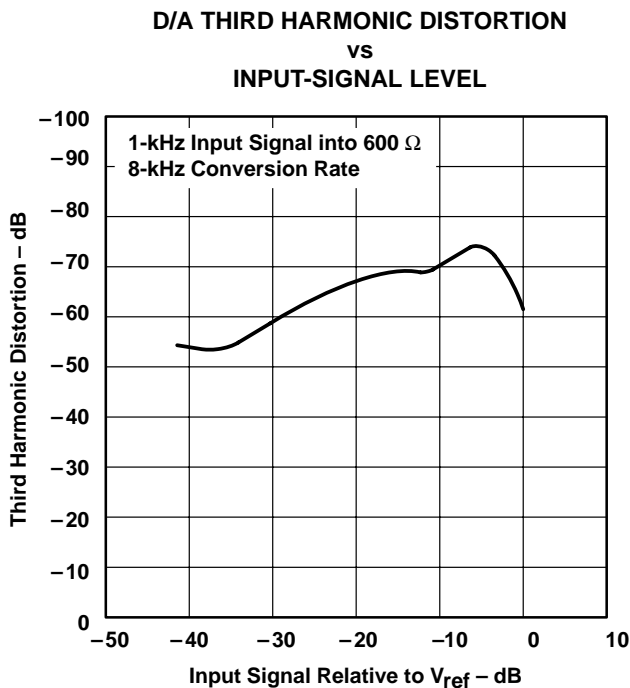

Figure 26

# TLC32044C, TLC32044E, TLC32044I, TLC32044M, TLC32045C, TLC32045I VOICE-BAND ANALOG INTERFACE CIRCUITS

SLAS017F – MARCH 1988 – REVISED MAY 1995

## APPLICATION INFORMATION

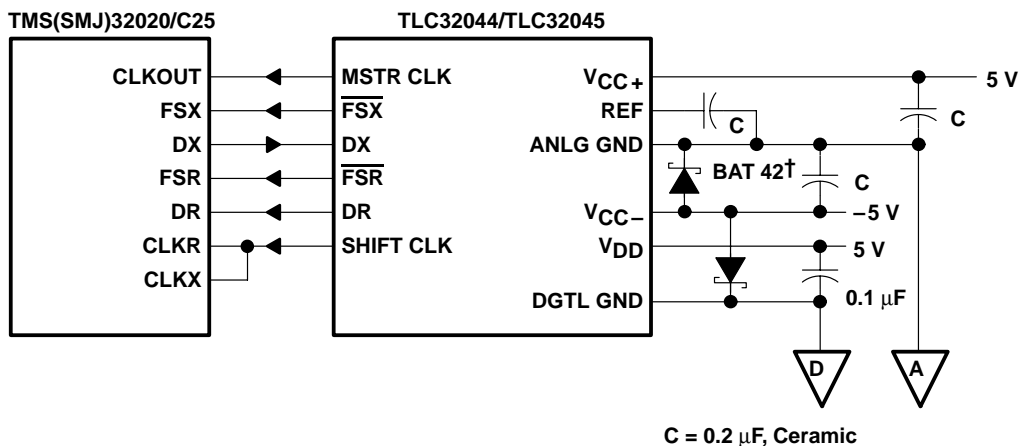

Figure 27. AIC Interface to the TMS(SMJ)32020/C25 Showing Decoupling Capacitors and Schottky Diode†

† Thomson Semiconductors

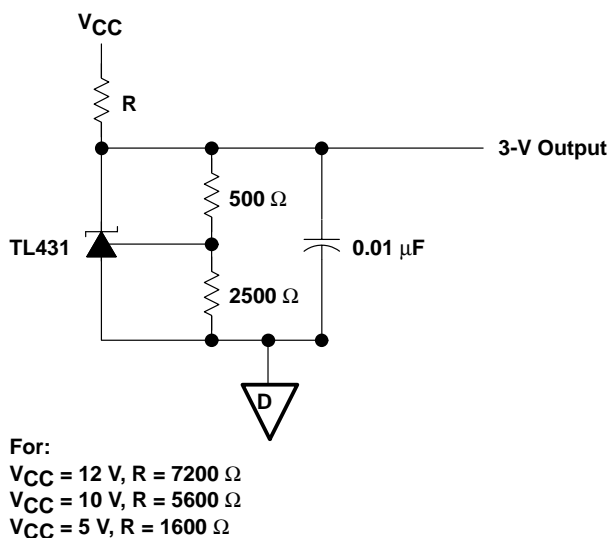

Figure 28. External Reference Circuit For TLC32044/TLC32045

## **IMPORTANT NOTICE**

Texas Instruments (TI) reserves the right to make changes to its products or to discontinue any semiconductor product or service without notice, and advises its customers to obtain the latest version of relevant information to verify, before placing orders, that the information being relied on is current.

TI warrants performance of its semiconductor products and related software to the specifications applicable at the time of sale in accordance with TI's standard warranty. Testing and other quality control techniques are utilized to the extent TI deems necessary to support this warranty. Specific testing of all parameters of each device is not necessarily performed, except those mandated by government requirements.

Certain applications using semiconductor products may involve potential risks of death, personal injury, or severe property or environmental damage ("Critical Applications").

**TI SEMICONDUCTOR PRODUCTS ARE NOT DESIGNED, INTENDED, AUTHORIZED, OR WARRANTED TO BE SUITABLE FOR USE IN LIFE-SUPPORT APPLICATIONS, DEVICES OR SYSTEMS OR OTHER CRITICAL APPLICATIONS.**

Inclusion of TI products in such applications is understood to be fully at the risk of the customer. Use of TI products in such applications requires the written approval of an appropriate TI officer. Questions concerning potential risk applications should be directed to TI through a local SC sales office.

In order to minimize risks associated with the customer's applications, adequate design and operating safeguards should be provided by the customer to minimize inherent or procedural hazards.

TI assumes no liability for applications assistance, customer product design, software performance, or infringement of patents or services described herein. Nor does TI warrant or represent that any license, either express or implied, is granted under any patent right, copyright, mask work right, or other intellectual property right of TI covering or relating to any combination, machine, or process in which such semiconductor products or services might be or are used.