

ADC0808, ADC0809 CMOS ANALOG-TO-DIGITAL CONVERTERS WITH 8-CHANNEL MULTIPLEXERS

SLAS036 – JUNE 1981 – REVISED MAY 1988

- Total Unadjusted Error . . . ± 0.75 LSB Max for ADC0808 and ± 1.25 LSB Max for ADC0809
- Resolution of 8 Bits
- 100- μ s Conversion Time
- Ratiometric Conversion
- Monotonicity Over the Entire A/D Conversion Range
- No Missing Codes
- Easy interface with Microprocessors
- Latched 3-State Outputs
- Latched Address inputs
- Single 5-V Supply
- Low Power Consumption
- Designed to Be Interchangeable With National Semiconductor ADC0808, ADC0809

description

The ADC0808 and ADC0809 are monolithic CMOS devices with an 8-channel multiplexer, an 8-bit analog-to-digital (A/D) converter, and microprocessor-compatible control logic. The 8-channel multiplexer can be controlled by a microprocessor through a 3-bit address decoder with address load to select any one of eight single-ended analog switches connected directly to the comparator. The 8-bit A/D converter uses the successive-approximation conversion technique featuring a high-impedance threshold detector, a switched-capacitor array, a sample-and-hold, and a successive-approximation register (SAR). Detailed information on interfacing to most popular microprocessors is readily available from the factory.

The comparison and converting methods used eliminate the possibility of missing codes, nonmonotonicity, and the need for zero or full-scale adjustment. Also featured are latched 3-state outputs from the SAR and latched inputs to the multiplexer address decoder. The single 5-V supply and low power requirements make the ADC0808 and ADC0809 especially useful for a wide variety of applications. Ratiometric conversion is made possible by access to the reference voltage input terminals.

The ADC0808 and ADC0809 are characterized for operation from -40°C to 85°C .

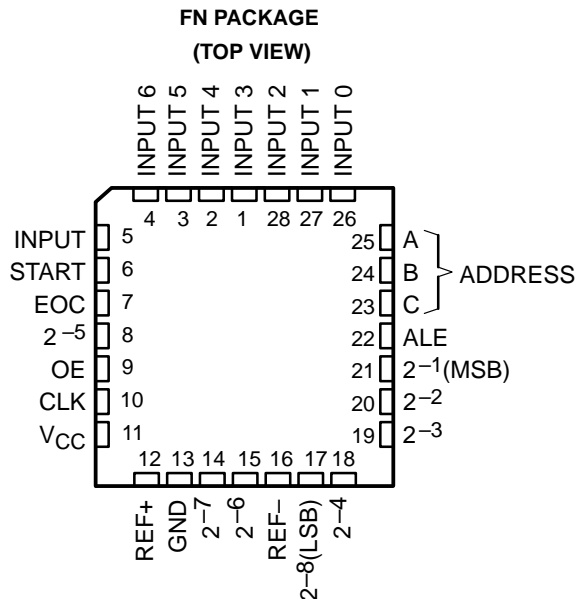
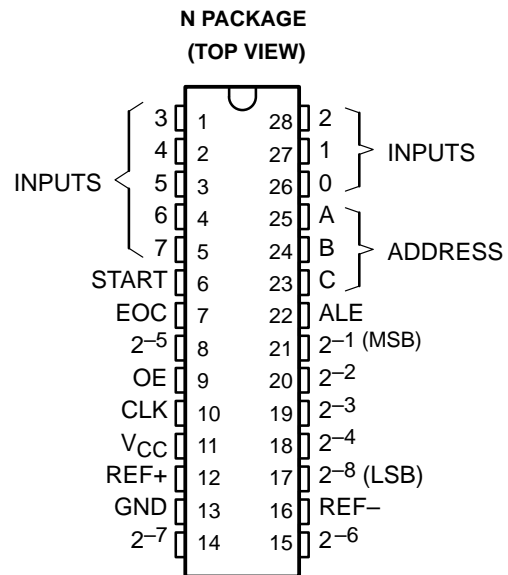

ADC0808, ADC0809 CMOS ANALOG-TO-DIGITAL CONVERTERS WITH 8-CHANNEL MULTIPLEXERS

SLAS036 – JUNE 1981 – REVISED MAY 1988

functional block diagram (positive logic)

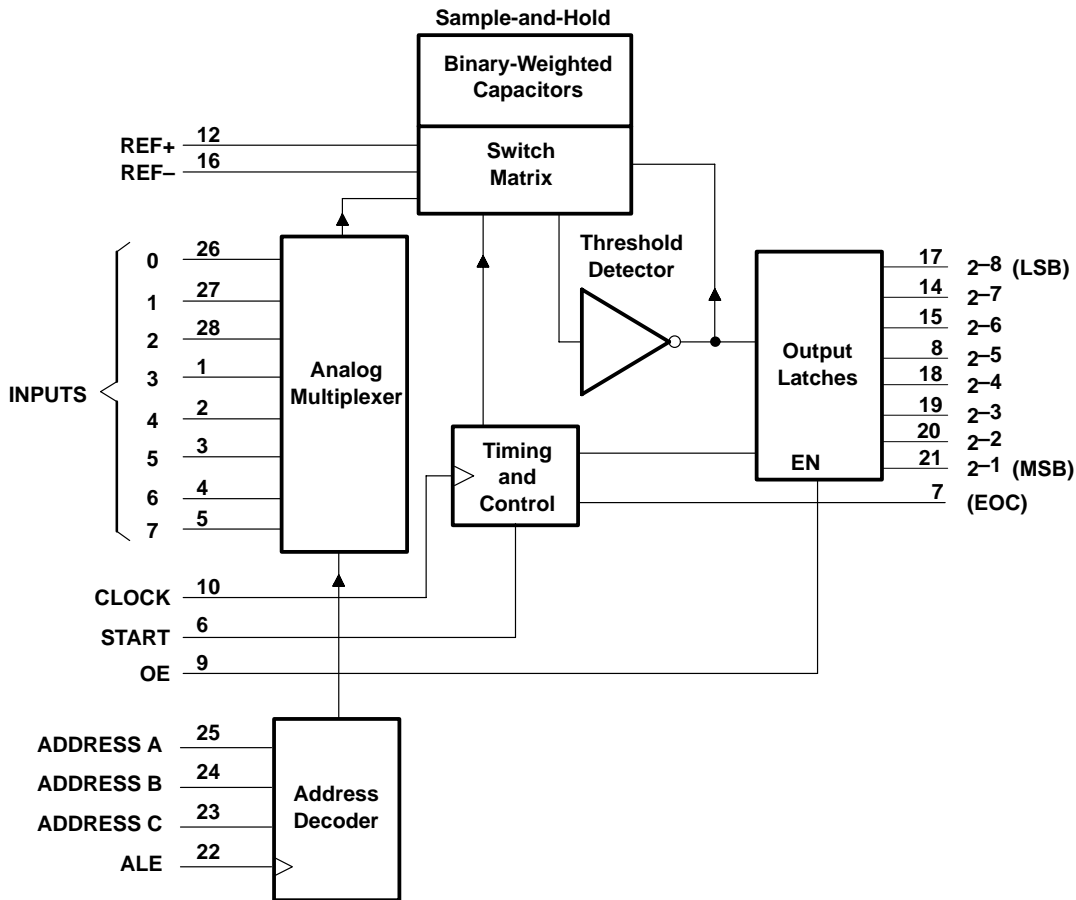

FUNCTION TABLE

INPUTS				SELECTED ANALOG CHANNEL
ADDRESS			ALE	
C	B	A		ALE
L	L	L	↑	0
L	L	H	↑	1
L	H	L	↑	2
L	H	H	↑	3
H	L	L	↑	4
H	L	H	↑	5
H	H	L	↑	6
H	H	H	↑	7

H = high level, L = low level
↑ = low-to-high transition



ADC0808, ADC0809
 CMOS ANALOG-TO-DIGITAL CONVERTERS
 WITH 8-CHANNEL MULTIPLEXERS

SLAS036 – JUNE 1981 – REVISED MAY 1988

operating sequence

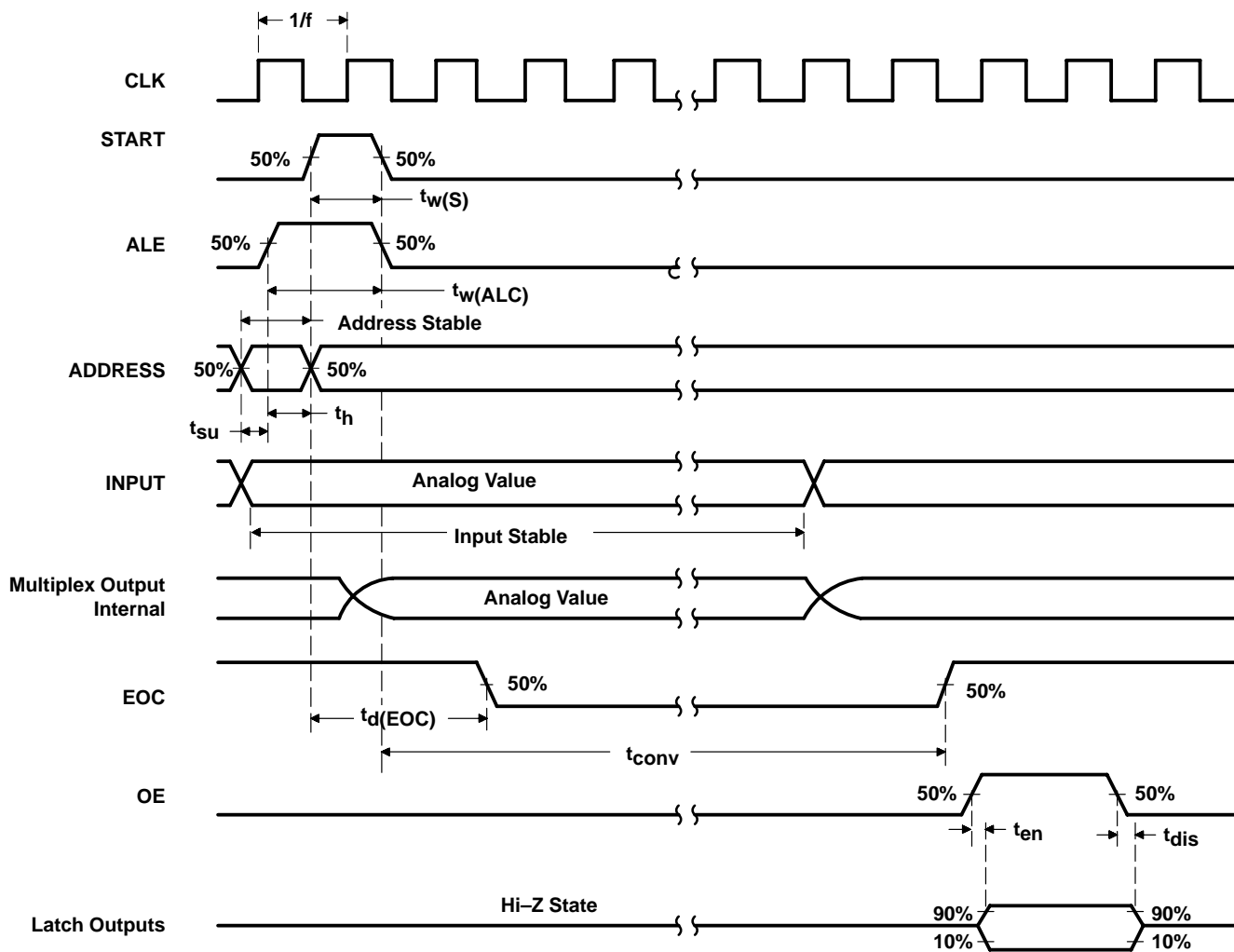

ADC0808, ADC0809

CMOS ANALOG-TO-DIGITAL CONVERTERS

WITH 8-CHANNEL MULTIPLEXERS

SLAS036 – JUNE 1981 – REVISED MAY 1988

absolute maximum ratings over operating free-air temperature range (unless otherwise noted)

Supply voltage, V_{CC} (see Note 1)	6.5 V
Input voltage range: Control inputs	-0.3 V to 15 V
All other inputs	-0.3 V to $V_{CC} + 0.3$ V
Operating free-air temperature range	-40°C to 85°C
Storage temperature range	-65°C to 150°C
Case temperature for 10 seconds: FN package	260°C
Lead temperature 1,6 mm (1/16 inch) from case for 10 seconds: N package	260°C

NOTE 1: All voltage values are with respect to network ground terminal.

recommended operating conditions

	MIN	NOM	MAX	UNIT
Supply voltage, V_{CC}	4.5	5	6	V
Positive reference voltage, V_{ref+} (see Note 2)		V_{CC}	$V_{CC} + 0.1$	V
Negative reference voltage, V_{ref-}		0	-0.1	V
Differential reference voltage, $V_{ref+} - V_{ref-}$		5		V
High-level input voltage, V_{IH}	$V_{CC} - 1.5$			V
Low-level input voltage, V_{IL}			1.5	V
Operating free-air temperature, T_A	-40		85	°C

NOTE 2: Care must be taken that this rating is observed even during power-up.

electrical characteristics over recommended operating free-air temperature range. $V_{CC} = 4.75$ V to 5.25 V (unless otherwise noted)

PARAMETER		TEST CONDITIONS	MIN	TYP†	MAX	UNIT
V_{OH}	High-level output voltage	$I_O = -360 \mu A$	$V_{CC} - 0.4$			V
V_{OL}	Low-level output voltage	Data outputs			0.45	V
		End of conversion	$I_O = 1.2 \text{ mA}$		0.45	
I_{OZ}	Off-state (high-impedance-state) output current	$V_O = V_{CC}$			3	μA
		$V_O = 0$			-3	
I_I	Control input current at maximum input voltage	$V_I = 15 \text{ V}$			1	μA
I_{IL}	Low-level control input current	$V_I = 0$			-1	μA
I_{CC}	Supply current	$f_{clock} = 640 \text{ kHz}$		0.3	3	mA
C_i	Input capacitance, control inputs	$T_A = 25^\circ C$		10	15	pF
C_O	Output capacitance, data outputs	$T_A = 25^\circ C$		10	15	pF
	Resistance from REF+ to REF-			1000		k Ω

† Typical values are at $V_{CC} = 5 \text{ V}$ and $T_A = 25^\circ C$.



analog multiplexer

PARAMETER		TEST CONDITIONS	MIN	TYP†	MAX	UNIT	
I _{on}	Channel on-state current (see Note 3)	V _I = V _{CC} , f _{clock} = 640 kHz			2	μA	
		V _I = 0.1 V, f _{clock} = 640 kHz			-2		
I _{off}	Channel off-state current	V _{CC} = 5 V, T _A = 25°C	V _I = 5 V		10	200	nA
			V _I = 0		-10	-200	
		V _{CC} = 5 V	V _I = 5 V			1	μA
			V _I = 0			-1	

† Typical values are at V_{CC} = 5 V and T_A = 25°C.

NOTE 3: Channel on-state current is primarily due to the bias current into or out of the threshold detector, and it varies directly with clock frequency.

timing requirements, V_{CC} = V_{ref+} = 5 V, V_{ref-} = 0 V (unless otherwise noted)

PARAMETER		TEST CONDITIONS	MIN	TYP†	MAX	UNIT
f _{clock}	Clock frequency		10	640	1280	kHz
t _{conv}	Conversion time	See Note 4	90	100	116	μs
t _{w(s)}	Pulse duration, START		200			ns
t _{w(ALE)}	Pulse duration ALE		200			ns
t _{su}	Setup time, ADDRESS		50			ns
t _h	Hold time, ADDRESS		50			ns
t _d	Delay time, EOC	See Notes 4 and 5	0		14.5	μs

operating characteristics, T_A = 25°C, V_{CC} = V_{ref+} = 5 V, V_{ref-} = 0 V, f_{clock} = 640 kHz (unless otherwise noted)

PARAMETER	TEST CONDITIONS	ADC0808			ADC0809			UNIT
		MIN	TYP†	MAX	MIN	TYP†	MAX	
k _{SVS}	Supply voltage sensitivity	V _{CC} = V _{ref+} = 4.75 V to 5.25 V, T _A = -40°C to 85°C, See Note 6			±0.05			%/V
	Linearity error (see Note 7)				±0.25			LSB
	Zero error (see Note 8)				±0.25			LSB
	Total unadjusted error (see Note 9)	T _A = 25°C			±0.25 ±0.5			LSB
		T _A = -40°C to 85°C			±0.75			
		T _A = 0°C to 70°C			±1			
t _{en}	Output enable time	C _L = 50 pF,	R _L = 10 kΩ	80	250	80	250	ns
t _{dis}	Output disable time	C _L = 10 pF,	R _L = 10 kΩ	105	250	105	250	ns

† Typical values for all except supply voltage sensitivity are at V_{CC} = 5 V, and all are at T_A = 25°C.

- NOTES:
- Refer to the operating sequence diagram.
 - For clock frequencies other than 640 kHz, t_d(EOC) maximum is 8 clock periods plus 2 μs.
 - Supply voltage sensitivity relates to the ability of an analog-to-digital converter to maintain accuracy as the supply voltage varies. The supply and V_{ref+} are varied together and the change in accuracy is measured with respect to full-scale.
 - Linearity error is the maximum deviation from a straight line through the end points of the A/D transfer characteristic.
 - Zero error is the difference between 00000000 and the converted output for zero input voltage; full-scale error is the difference between 11111111 and the converted output for full-scale input voltage.
 - Total unadjusted error is the maximum sum of linearity error, zero error, and full-scale error.



ADC0808, ADC0809 CMOS ANALOG-TO-DIGITAL CONVERTERS WITH 8-CHANNEL MULTIPLEXERS

SLAS036 – JUNE 1981 – REVISED MAY 1988

PRINCIPLES OF OPERATION

The ADC0808 and ADC0809 each consists of an analog signal multiplexer, an 8-bit successive-approximation converter, and related control and output circuitry.

multiplexer

The analog multiplexer selects 1 of 8 single-ended input channels as determined by the address decoder. Address load control loads the address code into the decoder on a low-to-high transition. The output latch is reset by the positive-going edge of the start pulse. Sampling also starts with the positive-going edge of the start pulse and lasts for 32 clock periods. The conversion process may be interrupted by a new start pulse before the end of 64 clock periods. The previous data will be lost if a new start of conversion occurs before the 64th clock pulse. Continuous conversion may be accomplished by connecting the end-of-conversion output to the start input. If used in this mode, an external pulse should be applied after power up to assure start up.

converter

The CMOS threshold detector in the successive-approximation conversion system determines each bit by examining the charge on a series of binary-weighted capacitors (Figure 1). In the first phase of the conversion process, the analog input is sampled by closing switch S_C and all S_T switches, and by simultaneously charging all the capacitors to the input voltage.

In the next phase of the conversion process, all S_T and S_C switches are opened and the threshold detector begins identifying bits by identifying the charge (voltage) on each capacitor relative to the reference voltage. In the switching sequence, all eight capacitors are examined separately until all 8 bits are identified, and then the charge-convert sequence is repeated. In the first step of the conversion phase, the threshold detector looks at the first capacitor (weight = 128). Node 128 of this capacitor is switched to the reference voltage, and the equivalent nodes of all the other capacitors on the ladder are switched to REF-. If the voltage at the summing node is greater than the trip-point of the threshold detector (approximately one-half the V_{CC} voltage), a bit is placed in the output register, and the 128-weight capacitor is switched to REF-. If the voltage at the summing node is less than the trip point of the threshold detector, this 128-weight capacitor remains connected to REF+ through the remainder of the capacitor-sampling (bit-counting) process. The process is repeated for the 64-weight capacitor, the 32-weight capacitor, and so forth down the line, until all bits are counted.

With each step of the capacitor-sampling process, the initial charge is redistributed among the capacitors. The conversion process is successive approximation, but relies on charge redistribution rather than a successive-approximation register (and reference DAC) to count and weigh the bits from MSB to LSB.

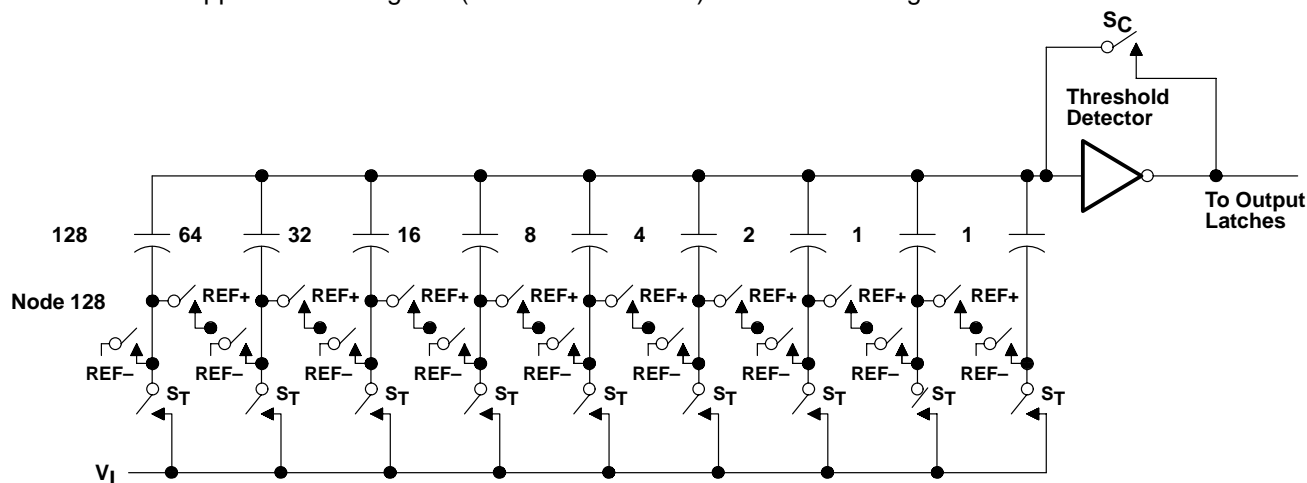

Figure 1. Simplified Model of the Successive-Approximation System



IMPORTANT NOTICE

Texas Instruments (TI) reserves the right to make changes to its products or to discontinue any semiconductor product or service without notice, and advises its customers to obtain the latest version of relevant information to verify, before placing orders, that the information being relied on is current.

TI warrants performance of its semiconductor products and related software to the specifications applicable at the time of sale in accordance with TI's standard warranty. Testing and other quality control techniques are utilized to the extent TI deems necessary to support this warranty. Specific testing of all parameters of each device is not necessarily performed, except those mandated by government requirements.

Certain applications using semiconductor products may involve potential risks of death, personal injury, or severe property or environmental damage ("Critical Applications").

TI SEMICONDUCTOR PRODUCTS ARE NOT DESIGNED, INTENDED, AUTHORIZED, OR WARRANTED TO BE SUITABLE FOR USE IN LIFE-SUPPORT APPLICATIONS, DEVICES OR SYSTEMS OR OTHER CRITICAL APPLICATIONS.

Inclusion of TI products in such applications is understood to be fully at the risk of the customer. Use of TI products in such applications requires the written approval of an appropriate TI officer. Questions concerning potential risk applications should be directed to TI through a local SC sales office.

In order to minimize risks associated with the customer's applications, adequate design and operating safeguards should be provided by the customer to minimize inherent or procedural hazards.

TI assumes no liability for applications assistance, customer product design, software performance, or infringement of patents or services described herein. Nor does TI warrant or represent that any license, either express or implied, is granted under any patent right, copyright, mask work right, or other intellectual property right of TI covering or relating to any combination, machine, or process in which such semiconductor products or services might be or are used.