

# TLV0834C, TLV0834I, TLV0838C, TLV0838I 3-VOLT 8-BIT ANALOG-TO-DIGITAL CONVERTERS WITH SERIAL CONTROL

SLAS147 – SEPTEMBER 1996

- 8-Bit Resolution
- 2.7 V to 3.6 V  $V_{CC}$
- Easy Microprocessor Interface or Standalone Operation
- Operates Ratiometrically or With  $V_{CC}$  Reference
- 4- or 8-Channel Multiplexer Options With Address Logic
- Input Range 0 V to  $V_{CC}$  With  $V_{CC}$  Reference
- Remote Operation With Serial Data Link
- Inputs and Outputs Are Compatible With TTL and MOS
- Conversion Time of 32  $\mu$ s at  $f_{(CLK)} = 250$  kHz
- Functionally Equivalent to the ADC0834 and ADC0838 at 3-V Supply Without the Internal Zener Regulator Network
- Total Unadjusted Error . . .  $\pm 1$  LSB

## description

These devices are 8-bit successive-approximation analog-to-digital converters, each with an input-configurable multichannel multiplexer and serial input/output. The serial input/output is configured to interface with standard shift registers or microprocessors. Detailed information on interfacing with most popular microprocessors is readily available from the factory.

The TLV0834 (4-channel) and TLV0838 (8-channel) multiplexer is software configured for single-ended or differential inputs as well as pseudo-differential input assignments. The differential analog voltage input allows for common-mode rejection or offset of the analog zero input voltage value. In addition, the voltage reference input can be adjusted to allow encoding of any smaller analog voltage span to the full 8 bits of resolution.

The TLV0834C and TLV0838C are characterized for operation from 0°C to 70°C. The TLV0834I and TLV0838I are characterized for operation from -40°C to 85°C.

TLV0834 . . . D OR N PACKAGE  
(TOP VIEW)

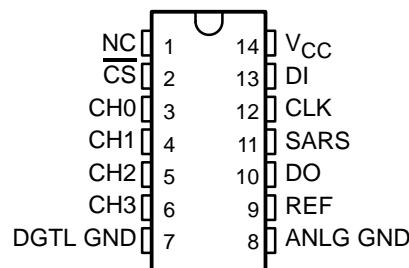

TLV0838 . . . DW OR N PACKAGE  
(TOP VIEW)

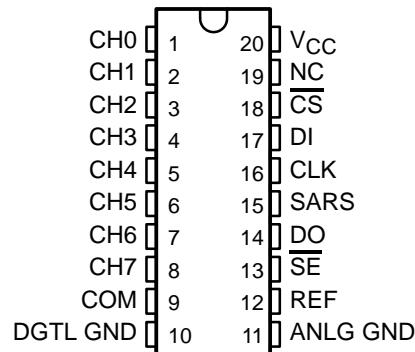

## AVAILABLE OPTIONS

T <sub>A</sub>	PACKAGE		
	SMALL OUTLINE (D)	SMALL OUTLINE (DW)	PLASTIC DIP (N)
0°C to 70°C	TLV0834CD	TLV0838CDW	TLV0834CN TLV0838CN
-40°C to 85°C	TLV0834ID	TLV0838IDW	TLV0834IN TLV0838IN



Please be aware that an important notice concerning availability, standard warranty, and use in critical applications of Texas Instruments semiconductor products and disclaimers thereto appears at the end of this data sheet.

PRODUCTION DATA information is current as of publication date. Products conform to specifications per the terms of Texas Instruments standard warranty. Production processing does not necessarily include testing of all parameters.

 **TEXAS  
INSTRUMENTS**

POST OFFICE BOX 655303 • DALLAS, TEXAS 75265

Copyright © 1996, Texas Instruments Incorporated

functional block diagram

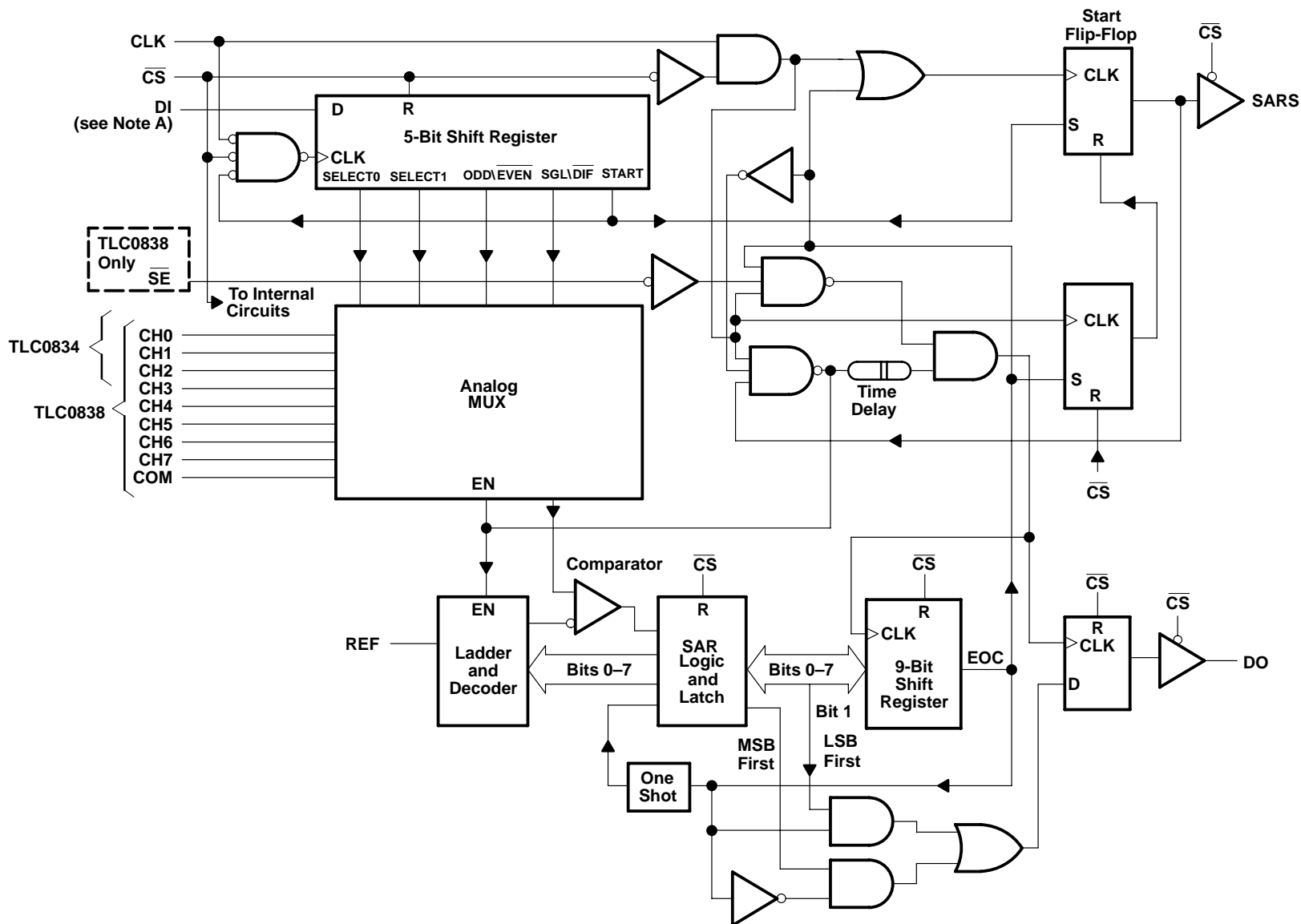

NOTE A: For the TLC0834, DI is input directly to the D input of SELECT1; SELECT0 is forced to a high.

## functional description

The TLV0834 and TLV0838 use a sample-data-comparator structure that converts differential analog inputs by a successive-approximation routine. Operation of both devices is similar with the exception of  $\overline{SE}$ , an analog common input, and multiplexer addressing. The input voltage to be converted is applied to a channel terminal and is compared to ground (single ended), to an adjacent input (differential), or to a common terminal (pseudo differential) that can be an arbitrary voltage. The input terminals are assigned a positive (+) or negative (–) polarity. When the signal input applied to the assigned positive terminal is less than the signal on the negative terminal, the converter output is all zeros.

Channel selection and input configuration are under software control using a serial-data link from the controlling processor. A serial-communication format allows more functions to be included in a converter package with no increase in size. In addition, it eliminates the transmission of low-level analog signals by locating the converter at the analog sensor and communicating serially with the controlling processor. This process returns noise-free digital data to the processor.

A particular input configuration is assigned during the multiplexer-addressing sequence. The multiplexer address shifts into the converter through the data input (DI) line. The multiplexer address selects the analog inputs to be enabled and determines whether the input is single ended or differential. When the input is differential, the polarity of the channel input is assigned. Differential inputs are assigned to adjacent channel pairs. For example, channel 0 and channel 1 may be selected as a differential pair. These channels cannot act differentially with any other channel. In addition to selecting the differential mode, the polarity may also be selected. Either channel of the channel pair may be designated as the negative or positive input.

The common input on the TLV0838 can be used for a pseudo-differential input. In this mode, the voltage on the common input is considered to be the negative differential input for all channel inputs. This voltage can be any reference potential common to all channel inputs. Each channel input can then be selected as the positive differential input. This feature is useful when all analog circuits are biased to a potential other than ground.

A conversion is initiated by setting  $\overline{CS}$  low, which enables all logic circuits.  $\overline{CS}$  must be held low for the complete conversion process. A clock input is then received from the processor. On each low-to-high transition of the clock input, the data on DI is clocked into the multiplexer-address shift register. The first logic high on the input is the start bit. A 3- to 4-bit assignment word follows the start bit. On each successive low-to-high transition of the clock input, the start bit and assignment word are shifted through the shift register. When the start bit is shifted into the start location of the multiplexer register, the input channel is selected and conversion starts. The SAR status output (SARS) goes high to indicate that a conversion is in progress, and DI to the multiplexer shift register is disabled for the duration of the conversion.

An interval of one clock period is automatically inserted to allow the selected multiplexed channel to settle. DO comes out of the high-impedance state and provides a leading low for one clock period of multiplexer settling time. The SAR comparator compares successive outputs from the resistive ladder with the incoming analog signal. The comparator output indicates whether the analog input is greater than or less than the resistive-ladder output. As the conversion proceeds, conversion data is simultaneously output from DO, with the most significant bit (MSB) first. After eight clock periods, the conversion is complete and SARS goes low.

The TLV0834 outputs the least-significant-bit (LSB) first data after the MSB-first data stream. When  $\overline{SE}$  is held high on the TLV0838, the value of the LSB remains on the data line. When  $\overline{SE}$  is forced low, the data is then clocked out as LSB-first data. (To output LSB first,  $\overline{SE}$  must first go low, then the data stored in the 9-bit shift register outputs LSB first.) When  $\overline{CS}$  goes high, all internal registers are cleared. At this time, the output circuits go to the high-impedance state. If another conversion is desired,  $\overline{CS}$  must make a high-to-low transition followed by address information.

DI and DO can be tied together and controlled by a bidirectional processor I/O bit received on a single wire. This is possible because DI is only examined during the multiplexer-addressing interval and DO is still in the high-impedance state.

# TLV0834C, TLV0834I, TLV0838C, TLV0838I

## 3-VOLT 8-BIT ANALOG-TO-DIGITAL CONVERTERS WITH SERIAL CONTROL

SLAS147 – SEPTEMBER 1996

### sequence of operation

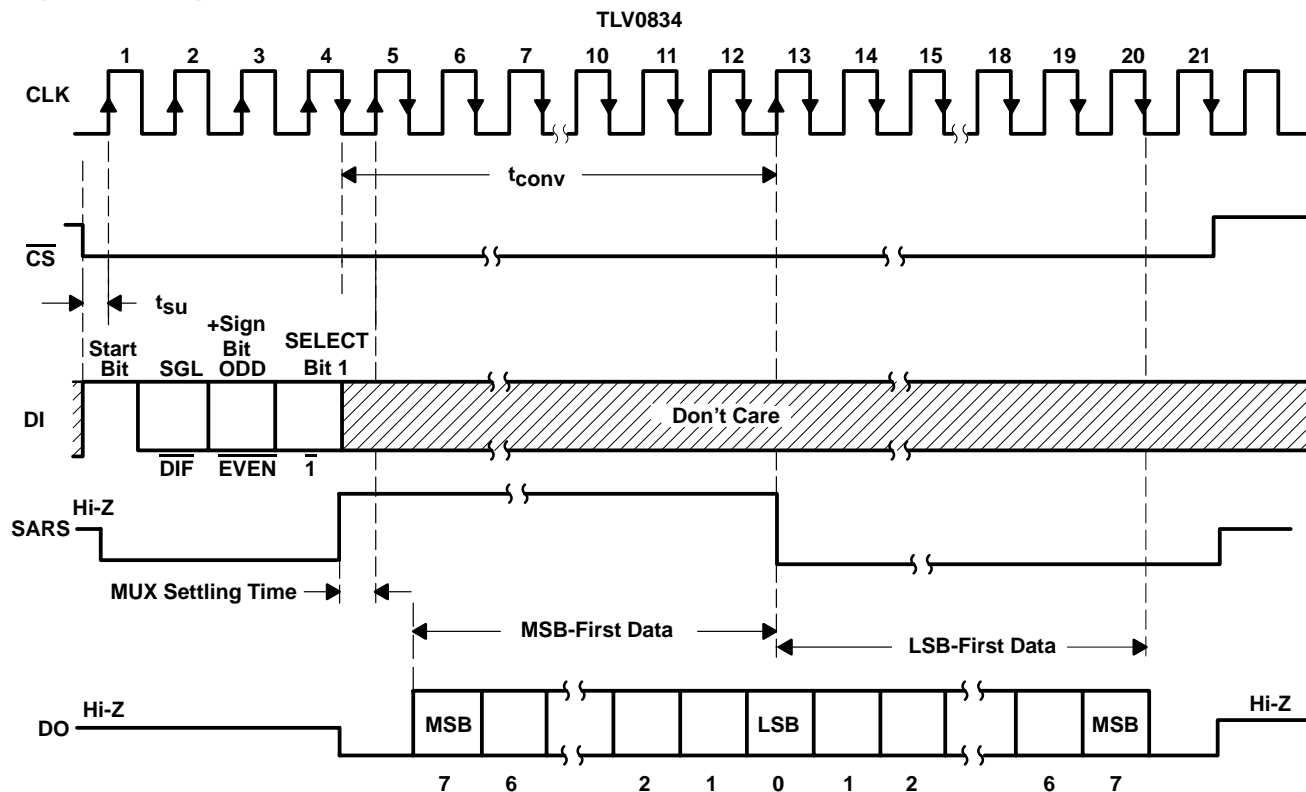

TLV0834 MUX-ADDRESS CONTROL LOGIC TABLE

MUX ADDRESS			CHANNEL NUMBER			
SGL/DIF	ODD/EVEN	SELECT BIT 1	CH0	CH1	CH2	CH3
L	L	L	+	-		
L	L	H			+	-
L	H	L	-	+		
L	H	H			-	+
H	L	L	+			
H	L	H			+	
H	H	L		+		
H	H	H				+

H = high level, L = low level, - or + = terminal polarity for the selected input channel



# TLV0834C, TLV0834I, TLV0838C, TLV0838I

## 3-VOLT 8-BIT ANALOG-TO-DIGITAL CONVERTERS WITH SERIAL CONTROL

SLAS147 – SEPTEMBER 1996

### sequence of operation

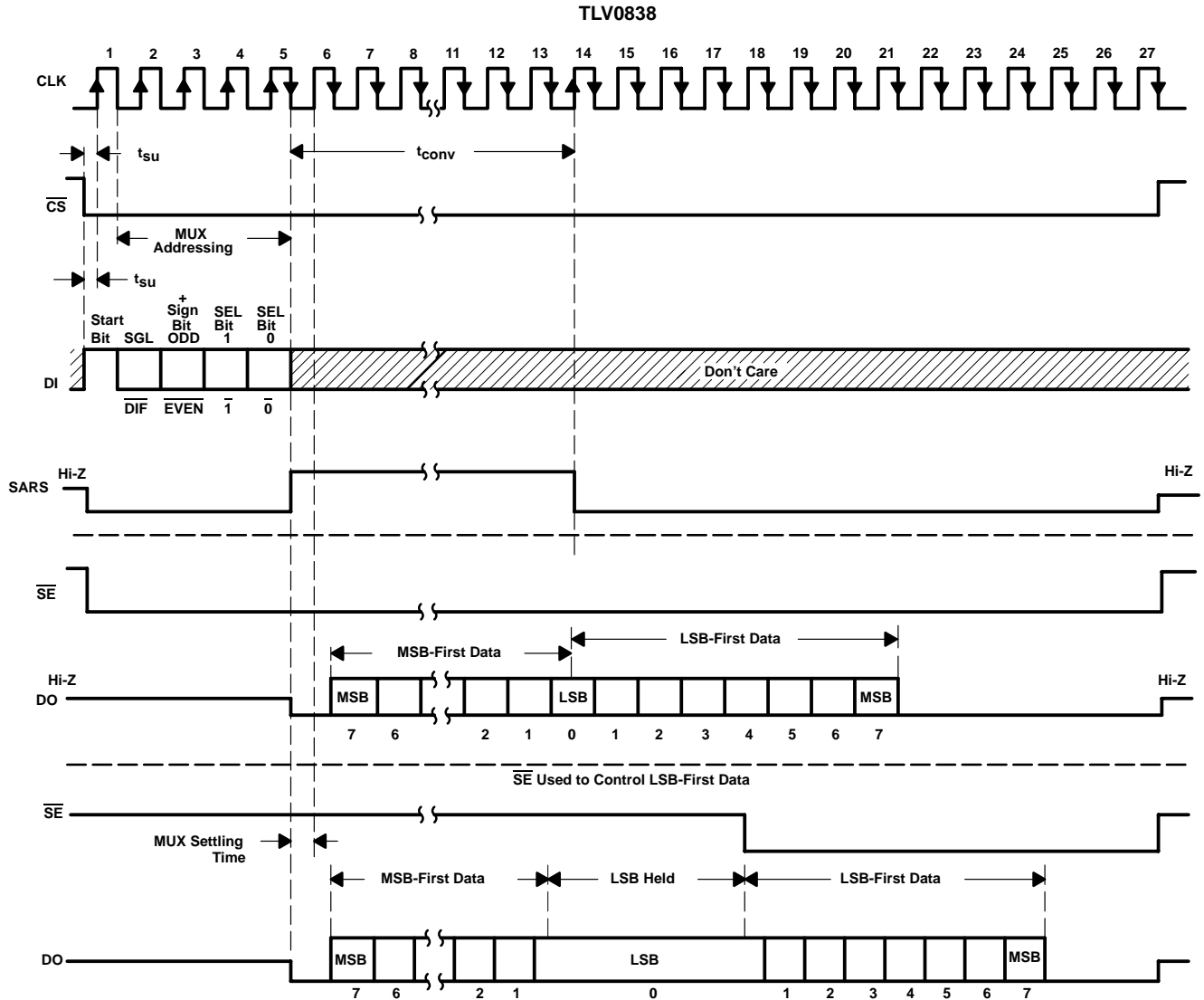

# TLV0834C, TLV0834I, TLV0838C, TLV0838I

## 3-VOLT 8-BIT ANALOG-TO-DIGITAL CONVERTERS WITH SERIAL CONTROL

SLAS147 – SEPTEMBER 1996

TLV0838 MUX-ADDRESS CONTROL LOGIC TABLE

MUX ADDRESS				SELECTED CHANNEL NUMBER								COM
SGL/DIF	ODD/EVEN	SELECT		0		1		2		3		
		1	0	CH0	CH1	CH2	CH3	CH4	CH5	CH6	CH7	
L	L	L	L	+	-							
L	L	L	H			+	-					
L	L	H	L					+	-			
L	L	H	H							+	-	
L	H	L	L	-	+							
L	H	L	H			-	+					
L	H	H	L					-	+			
L	H	H	H							-	+	
H	L	L	L	+								-
H	L	L	H			+						-
H	L	H	L					+				-
H	L	H	H							+		-
H	H	L	L		+							-
H	H	L	H				+					-
H	H	H	L					+				-
H	H	H	H								+	-

H = high level, L = low level, - or + = polarity of external input

### absolute maximum ratings over recommended operating free-air temperature range (unless otherwise noted)†

- Supply voltage,  $V_{CC}$  (see Note 1) ..... 6.5 V
- Input voltage range: Logic ..... -0.3 V to  $V_{CC} + 0.3$  V
- Analog ..... -0.3 V to  $V_{CC} + 0.3$  V
- Input current,  $I_I$  .....  $\pm 5$  mA
- Total input current .....  $\pm 20$  mA
- Operating free-air temperature range,  $T_A$ : C suffix ..... 0°C to 70°C
- I suffix ..... -40°C to 85°C
- Storage temperature range,  $T_{stg}$  ..... -65°C to 150°C
- Lead temperature 1,6 mm (1/16 inch) from case for 10 seconds: N package ..... 260°C

† Stresses beyond those listed under “absolute maximum ratings” may cause permanent damage to the device. These are stress ratings only, and functional operation of the device at these or any other conditions beyond those indicated under “recommended operating conditions” is not implied. Exposure to absolute-maximum-rated conditions for extended periods may affect device reliability.

NOTE 1: All voltage values, except differential voltages, are with respect to the network ground terminal.



# TLV0834C, TLV0834I, TLV0838C, TLV0838I

## 3-VOLT 8-BIT ANALOG-TO-DIGITAL CONVERTERS WITH SERIAL CONTROL

SLAS147 – SEPTEMBER 1996

### recommended operating conditions

		MIN	NOM	MAX	UNIT
Supply voltage, $V_{CC}$ (see clock frequency operating conditions)		2.7	3.3	3.6	V
High-level input voltage, $V_{IH}$		2			V
Low-level input voltage, $V_{IL}$		0.8			V
Clock frequency, $f_{(CLK)}$	$V_{CC} = 2.7\text{ V}$	10	250		kHz
Clock frequency, $f_{(CLK)}$	$V_{CC} = 3.3\text{ V}$	10	600		kHz
Clock duty cycle (see Note 2)		40%	60%		
Pulse duration, $\overline{CS}$ high, $t_{WH}(CS)$		220			ns
Setup time, $\overline{CS}$ low, $\overline{SE}$ low, or data valid before $CLK\uparrow$ , $t_{su}$		350			ns
Hold time, data valid after $CLK\uparrow$ , $t_h$		90			ns
Operating free-air temperature, $T_A$	C suffix	0		70	°C
	I suffix	-40		85	

NOTE 2: The clock-duty-cycle range ensures proper operation at all clock frequencies. When a clock frequency is used outside the recommended duty-cycle range, the minimum pulse duration (high or low) is 1  $\mu$ s.

### electrical characteristics over recommended range of operating free-air temperature, $V_{CC} = 3.3\text{ V}$ , $f_{(CLK)} = 250\text{ kHz}$ (unless otherwise noted)

#### digital section

PARAMETER	TEST CONDITIONS†	C SUFFIX			I SUFFIX			UNIT
		MIN	TYP‡	MAX	MIN	TYP‡	MAX	
$V_{OH}$ High-level output voltage	$V_{CC} = 3\text{ V}$ , $I_{OH} = -360\ \mu\text{A}$	2.8			2.4			V
	$V_{CC} = 3\text{ V}$ , $I_{OH} = -10\ \mu\text{A}$	2.9			2.8			
$V_{OL}$ Low-level output voltage	$V_{CC} = 3\text{ V}$ , $I_{OL} = 1.6\text{ mA}$	0.34			0.4			V
$I_{IH}$ High-level input current	$V_{IH} = 3.6\text{ V}$	0.005	1		0.005	1		$\mu\text{A}$
$I_{IL}$ Low-level input current	$V_{IL} = 0$	-0.005	-1		-0.005	-1		$\mu\text{A}$
$I_{OH}$ High-level output (source) current	At $V_{OH}$ , $DO = 0\text{ V}$ , $T_A = 25^\circ\text{C}$	-6.5	-15		-6.5	-15		mA
$I_{OL}$ Low-level output (sink) current	At $V_{OL}$ , $DO = V_{CC}$ , $T_A = 25^\circ\text{C}$	8	16		8	16		mA
$I_{OZ}$ High-impedance-state output current (DO or SARS)	$V_O = 3.3\text{ V}$ , $T_A = 25^\circ\text{C}$	0.01			3			$\mu\text{A}$
	$V_O = 0$ , $T_A = 25^\circ\text{C}$	-0.01			-3			
$C_i$ Input capacitance					5			pF
$C_o$ Output capacitance					5			pF

† All parameters are measured under open-loop conditions with zero common-mode input voltage (unless otherwise specified).

‡ All typical values are at  $V_{CC} = 3.3\text{ V}$ ,  $T_A = 25^\circ\text{C}$ .

# TLV0834C, TLV0834I, TLV0838C, TLV0838I

## 3-VOLT 8-BIT ANALOG-TO-DIGITAL CONVERTERS WITH SERIAL CONTROL

SLAS147 – SEPTEMBER 1996

### analog and converter section

PARAMETER		TEST CONDITIONS†	MIN	TYP‡	MAX	UNIT
$V_{IC}$	Common-mode input voltage	See Note 3	-0.05 to $V_{CC}+0.05$			V
$I_{I(stdby)}$	Standby input current (see Note 4)	On channel	$V_I = 3.3\text{ V}$		1	$\mu\text{A}$
		Off channel	$V_I = 0$		-1	
		On channel	$V_I = 0$		-1	
		Off channel	$V_I = 3.3\text{ V}$		1	
$r_{i(REF)}$	Input resistance to REF		1.3	2.4	5.9	$\text{k}\Omega$

### total device

PARAMETER		MIN	TYP‡	MAX	UNIT
$I_{CC}$	Supply current		0.2	0.75	$\text{mA}$

† All parameters are measured under open-loop conditions with zero common-mode input voltage.

‡ All typical values are at  $V_{CC} = 3.3\text{ V}$ ,  $T_A = 25^\circ\text{C}$ .

NOTES: 3. When channel IN- is more positive than channel IN+, the digital output code is 0000 0000. Connected to each analog input are two on-chip diodes that conduct forward current for analog input voltages one diode drop above  $V_{CC}$ . Care must be taken during testing at low  $V_{CC}$  levels (3 V) because high-level analog input voltage (3.6 V) can, especially at high temperatures, cause the input diode to conduct and cause errors for analog inputs that are near full scale. As long as the analog voltage does not exceed the supply voltage by more than 50 mV, the output code is correct. To achieve an absolute 0- to 3.3-V input range requires a minimum  $V_{CC}$  of 3.25 V for all variations of temperature and load.

4. Standby input currents go in or out of the on or off channels when the A/D converter is not performing conversion and the clock is in a high or low steady-state condition.

### operating characteristics, $V_{CC} = 3.3\text{ V}$ , $f_{(CLK)} = 250\text{ kHz}$ , $t_r = t_f = 20\text{ ns}$ , $T_A = 25^\circ\text{C}$ (unless otherwise noted)

PARAMETER		TEST CONDITIONS§	MIN	TYP	MAX	UNIT
Supply-voltage variation error		$V_{CC} = 3\text{ V to }3.6\text{ V}$		$\pm 1/16$	$\pm 1/4$	LSB
Total unadjusted error (see Note 5)		$V_{ref} = 3.3\text{ V}$ , $T_A = \text{MIN to MAX}$			$\pm 1$	LSB
Common-mode error		Differential mode		$\pm 1/16$	$\pm 1/4$	LSB
$t_{pd}$	Propagation delay time, output data after $\text{CLK}\downarrow$ (see Note 6)	MSB-first data	$C_L = 100\text{ pF}$		500	ns
		LSB-first data			200	
$t_{dis}$	Output disable time, DO or SARS after $\text{CS}\uparrow$	$C_L = 10\text{ pF}$ , $R_L = 10\text{ k}\Omega$			80	ns
		$C_L = 100\text{ pF}$ , $R_L = 2\text{ k}\Omega$			250	
$t_{conv}$	Conversion time (multiplexer-addressing time not included)				8	clock periods

§ All parameters are measured under open-loop conditions with zero common-mode input voltage. For conditions shown as MIN or MAX, use the appropriate value specified under recommended operating conditions.

NOTES: 5. Total unadjusted error includes offset, full-scale, linearity, and multiplexer errors.

6. The MSB-first data is output directly from the comparator and, therefore, requires additional delay to allow for comparator response time.





PARAMETER MEASUREMENT INFORMATION

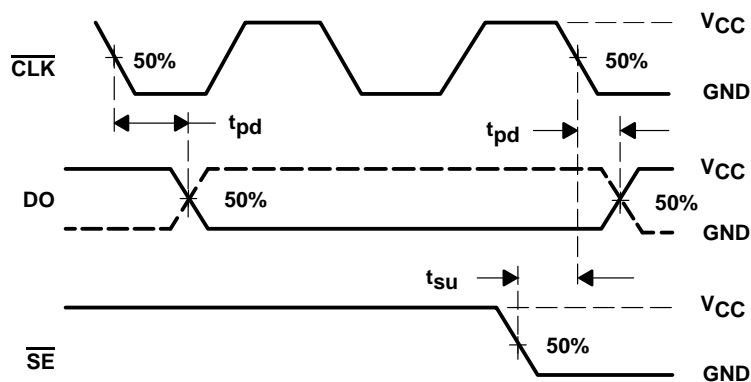
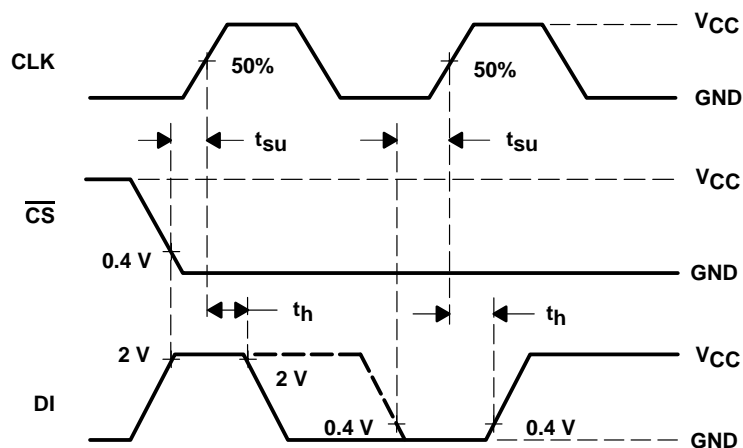

Figure 2. Data-Output Timing

# TLV0834C, TLV0834I, TLV0838C, TLV0838I

## 3-VOLT 8-BIT ANALOG-TO-DIGITAL CONVERTERS WITH SERIAL CONTROL

SLAS147 – SEPTEMBER 1996

### PARAMETER MEASUREMENT INFORMATION

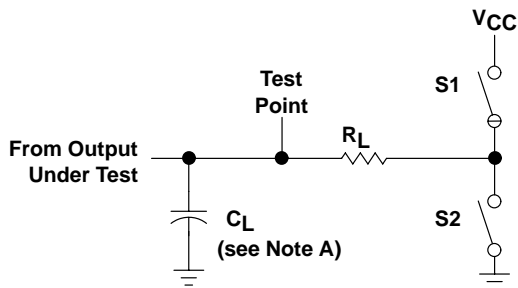

LOAD CIRCUIT

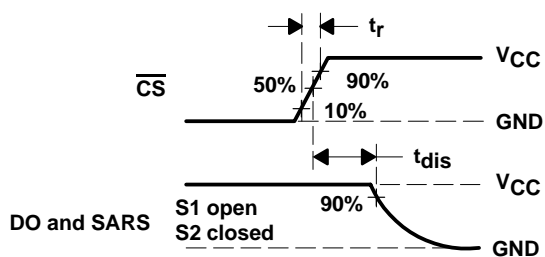

VOLTAGE WAVEFORMS

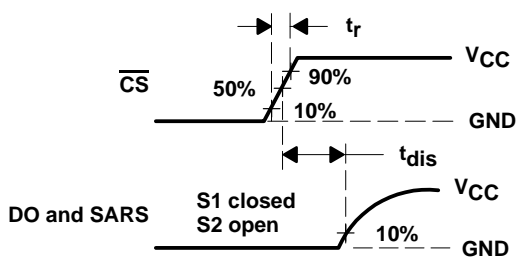

VOLTAGE WAVEFORMS

NOTE A:  $C_L$  includes probe and jig capacitance.

Figure 3. Output Disable Time Test Circuit and Voltage Waveforms

TYPICAL CHARACTERISTICS

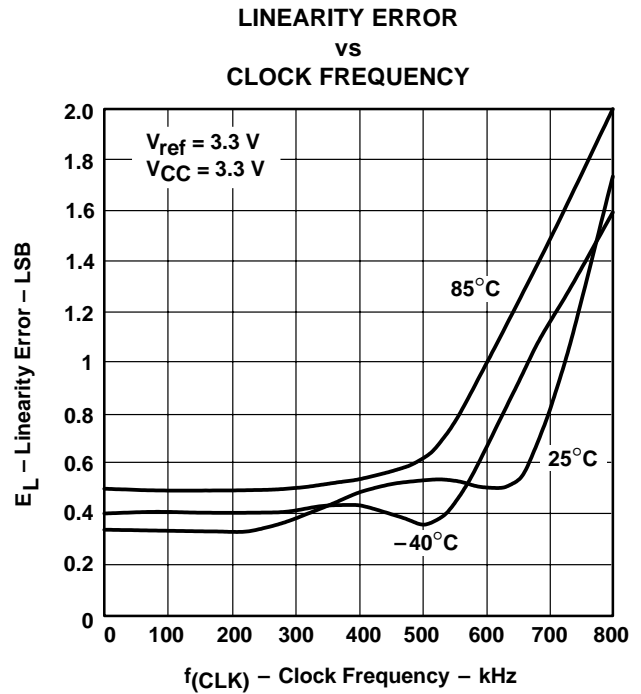
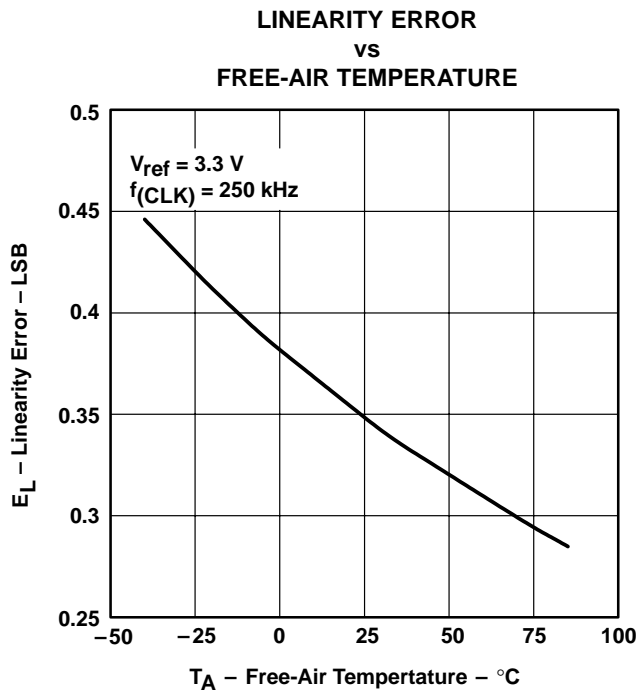
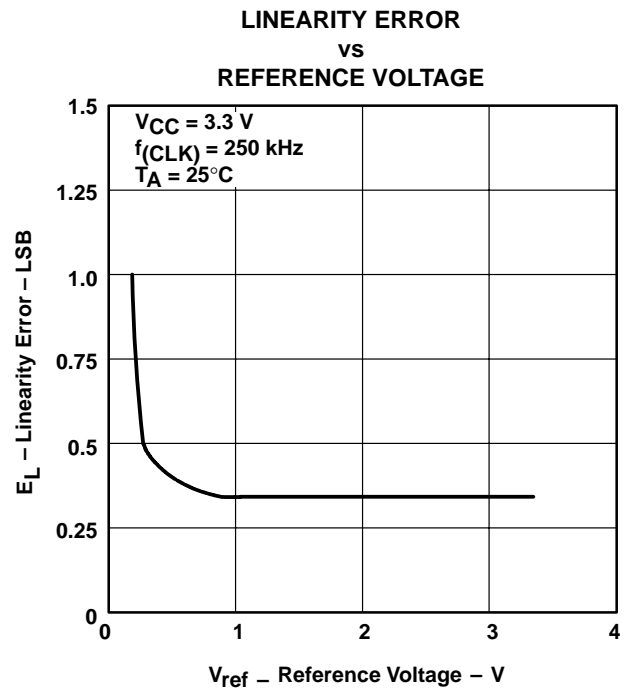
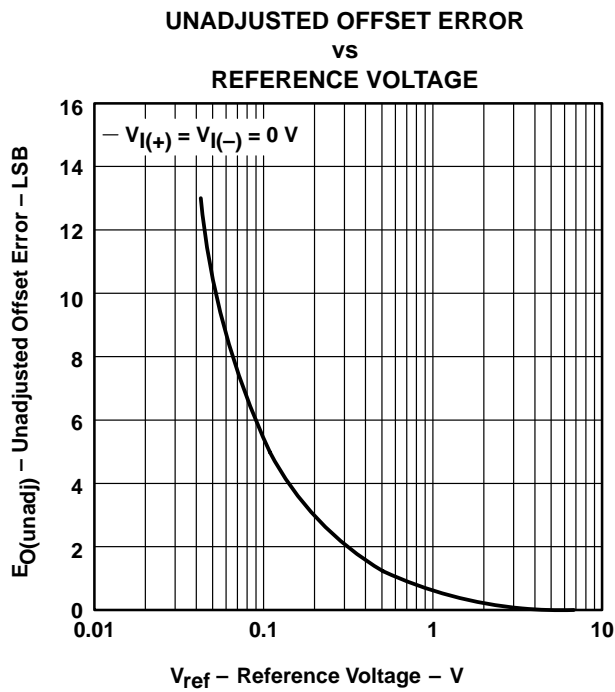

# TLV0834C, TLV0834I, TLV0838C, TLV0838I

## 3-VOLT 8-BIT ANALOG-TO-DIGITAL CONVERTERS WITH SERIAL CONTROL

SLAS147 – SEPTEMBER 1996

### TYPICAL CHARACTERISTICS

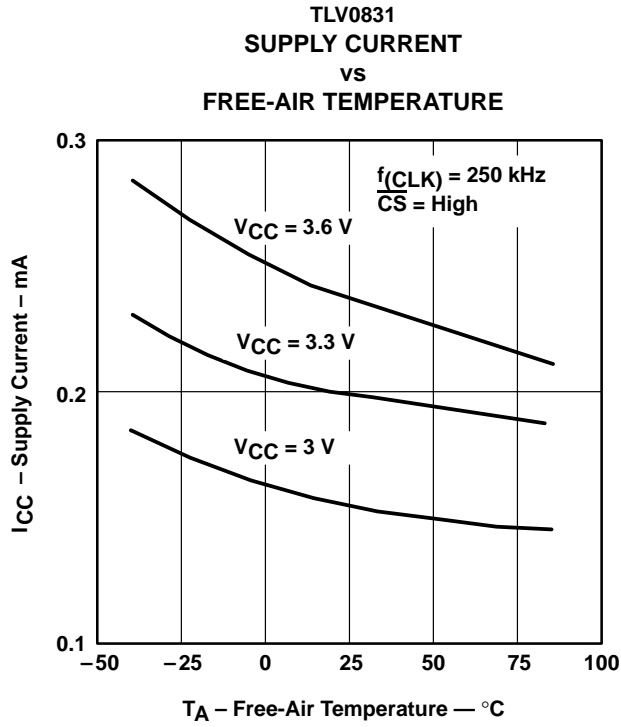

Figure 8

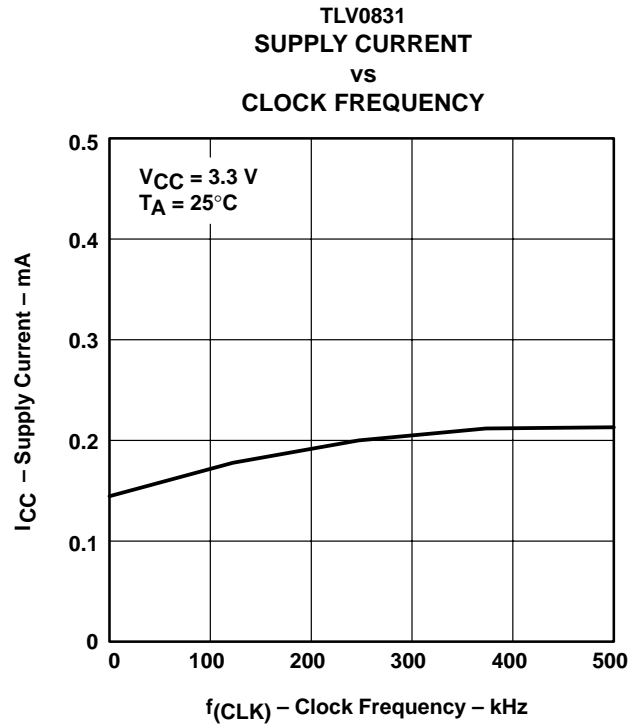

Figure 9

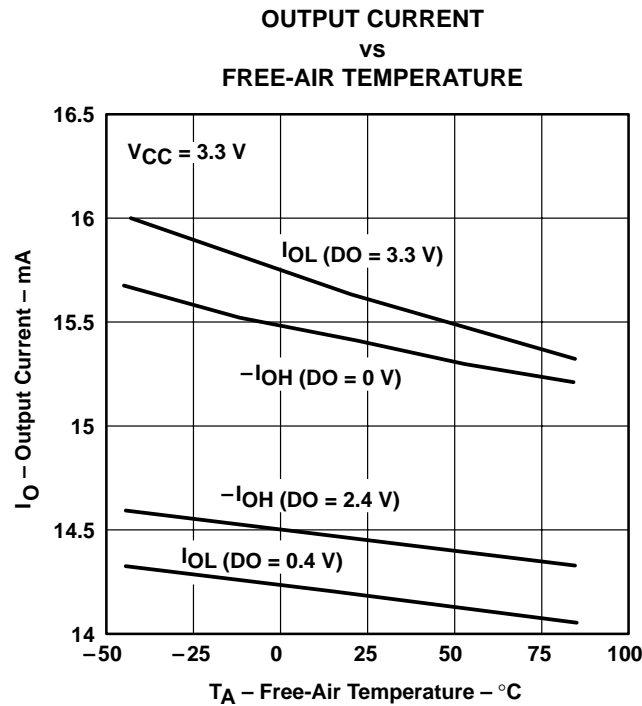

Figure 10



TYPICAL CHARACTERISTICS

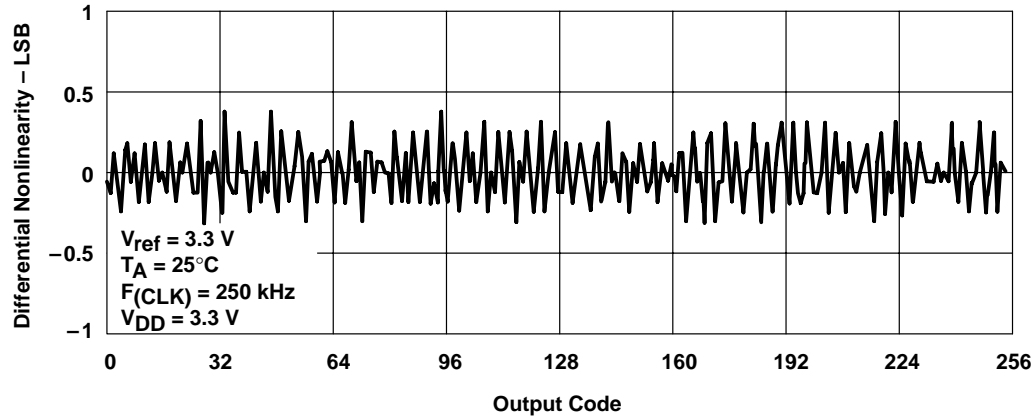

Figure 11. Differential Nonlinearity With Output Code

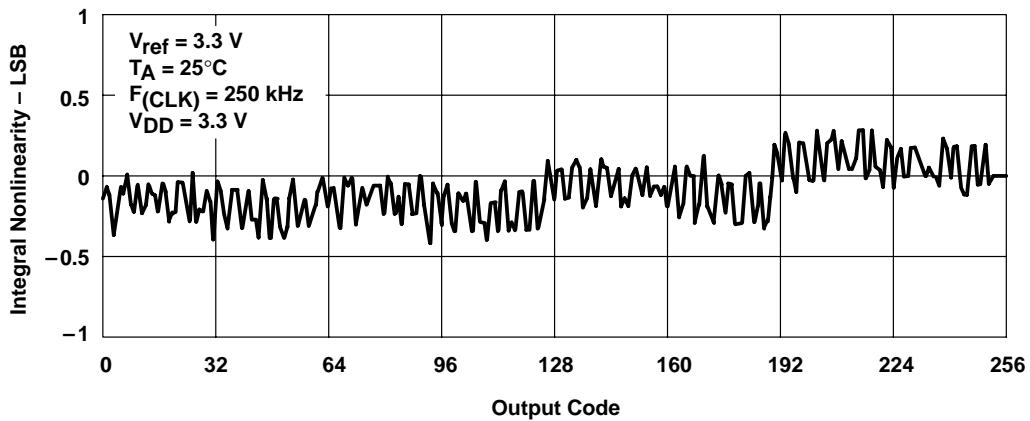

Figure 12. Integral Nonlinearity With Output Code

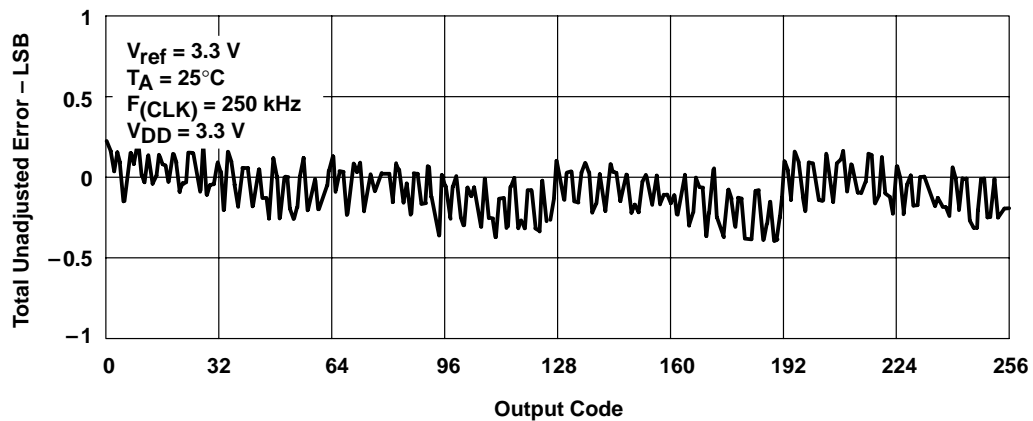

Figure 13. Total Unadjusted Error With Output Code

## **IMPORTANT NOTICE**

Texas Instruments (TI) reserves the right to make changes to its products or to discontinue any semiconductor product or service without notice, and advises its customers to obtain the latest version of relevant information to verify, before placing orders, that the information being relied on is current.

TI warrants performance of its semiconductor products and related software to the specifications applicable at the time of sale in accordance with TI's standard warranty. Testing and other quality control techniques are utilized to the extent TI deems necessary to support this warranty. Specific testing of all parameters of each device is not necessarily performed, except those mandated by government requirements.

Certain applications using semiconductor products may involve potential risks of death, personal injury, or severe property or environmental damage ("Critical Applications").

**TI SEMICONDUCTOR PRODUCTS ARE NOT DESIGNED, INTENDED, AUTHORIZED, OR WARRANTED TO BE SUITABLE FOR USE IN LIFE-SUPPORT APPLICATIONS, DEVICES OR SYSTEMS OR OTHER CRITICAL APPLICATIONS.**

Inclusion of TI products in such applications is understood to be fully at the risk of the customer. Use of TI products in such applications requires the written approval of an appropriate TI officer. Questions concerning potential risk applications should be directed to TI through a local SC sales office.

In order to minimize risks associated with the customer's applications, adequate design and operating safeguards should be provided by the customer to minimize inherent or procedural hazards.

TI assumes no liability for applications assistance, customer product design, software performance, or infringement of patents or services described herein. Nor does TI warrant or represent that any license, either express or implied, is granted under any patent right, copyright, mask work right, or other intellectual property right of TI covering or relating to any combination, machine, or process in which such semiconductor products or services might be or are used.