

TL712 DIFFERENTIAL COMPARATOR

SLCS002B – JUNE 1983 – REVISED DECEMBER 1992

- Operates From a Single 5-V Supply
- 0 to 5 V Common-Mode Input Voltage Range
- Self-Biased Inputs
- Complementary 3-State Outputs
- Enable Capability
- Hysteresis . . . 5 mV Typ
- Response Times . . . 25 ns Typ

D, JG, P, OR PW PACKAGE
(TOP VIEW)

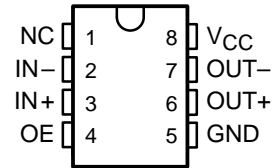

NC—No internal connection

description

The TL712 is a high-speed comparator fabricated with bipolar Schottky process technology. The circuit has differential analog inputs and complementary 3-state TTL-compatible logic outputs with symmetrical switching characteristics. When the output enable, (OE), is low, both outputs are in the high-impedance state. This device operates from a single 5-V supply and is useful as a disk memory read-chain data comparator.

The TL712 is characterized for operation from 0°C to 70°C.

symbol (positive logic)

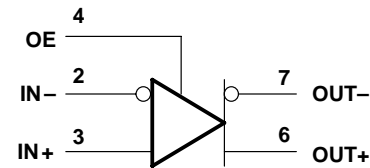

schematics of inputs and outputs

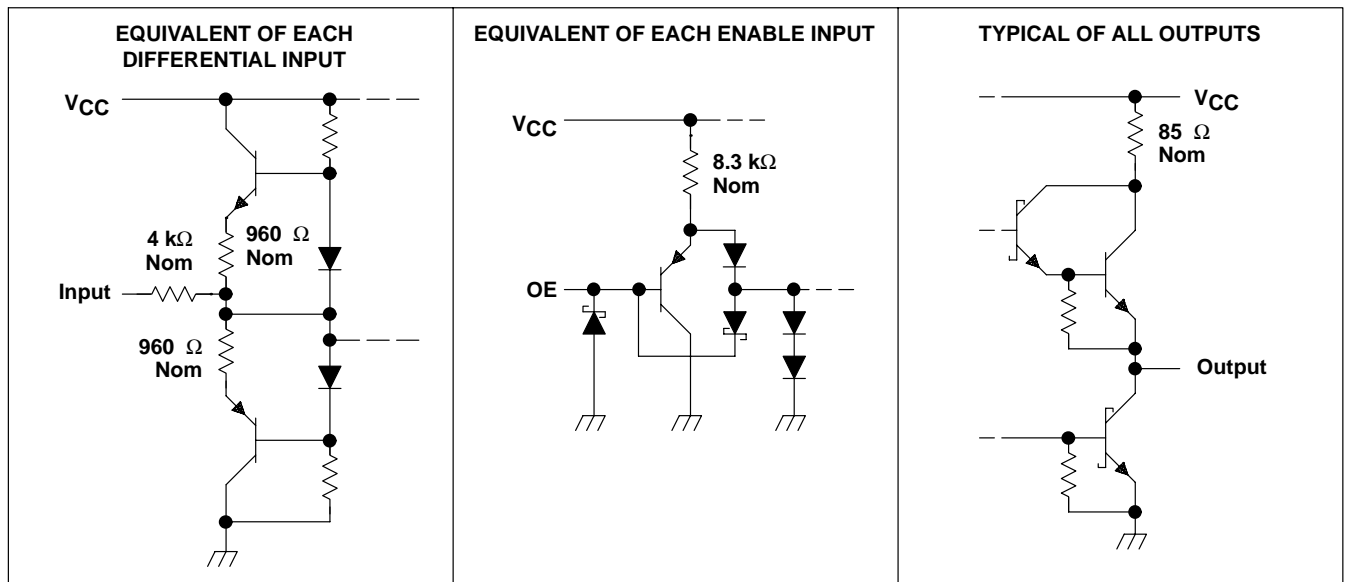

PRODUCTION DATA information is current as of publication date. Products conform to specifications per the terms of Texas Instruments standard warranty. Production processing does not necessarily include testing of all parameters.

 **TEXAS
INSTRUMENTS**

POST OFFICE BOX 655303 • DALLAS, TEXAS 75265

Copyright © 1992, Texas Instruments Incorporated

TL712

DIFFERENTIAL COMPARATOR

SLCS002B – JUNE 1983 – REVISED DECEMBER 1992

absolute maximum ratings over operating free-air temperature range (unless otherwise noted)†

| | |
|---|----------------|
| Supply voltage, V_{CC} (see Note 1) | 7 V |
| Input voltage, V_I , any differential input | ± 25 V |
| Differential input voltage, V_{ID} (see Note 2) | ± 25 V |
| Enable input voltage | 7 V |
| Low-level output current, I_{OL} | 50 mA |
| Operating free-air temperature range, T_A | 0°C to 70°C |
| Storage temperature range | -65°C to 150°C |
| Lead temperature 1,6 mm (1/16 inch) from case for 60 seconds: JG package | 300°C |
| Lead temperature 1,6 mm (1/16 inch) from case for 10 seconds: D, P, or PW package | 260°C |

† Stresses beyond those listed under “absolute maximum ratings” may cause permanent damage to the device. These are stress ratings only, and functional operation of the device at these or any other conditions beyond those indicated in the “recommended operating conditions” section of this specification is not implied. Exposure to absolute-maximum-rated conditions for extended periods may affect device reliability.

- NOTES: 1. All voltage values, except differential voltages, are with respect to the network ground.
2. Differential voltage values are at $IN+$ with respect to $IN-$.

recommended operating conditions

| | MIN | NOM | MAX | UNIT |
|---------------------------------------|------|-----|------|------|
| Supply voltage, V_{CC} | 4.75 | 5 | 5.25 | V |
| Common-mode input voltage, V_{IC} | 0 | | 5 | V |
| High-level output current, I_{OH} | | | -1 | mA |
| Low-level output current, I_{OL} | | | 16 | mA |
| Operating free-air temperature, T_A | 0 | | 70 | °C |

electrical characteristics at $V_{CC} = 5$ V, $T_A = 25^\circ\text{C}$

| PARAMETER | TEST CONDITIONS | MIN | TYP | MAX | UNIT |
|---|--------------------------------------|-------|-----|------|---------------|
| V_T Threshold voltage (V_{T+} and V_{T-}) | $V_{ICR} = 0$ to 5 V | -100‡ | | 100 | mV |
| V_{hys} Hysteresis ($V_{T+} - V_{T-}$) | | | 5 | | mV |
| V_{OH} High-level output voltage | $V_{ID} = 100$ mV, $I_{OH} = -1$ mA | 2.7 | 3.5 | | V |
| V_{OL} Low-level output voltage | $V_{ID} = -100$ mV, $I_{OL} = 16$ mA | | 0.4 | 0.5 | V |
| I_{OZ} Off-state output current | $V_O = 2.4$ V | | | -20 | μA |
| I_I Enable current | $V_I = 5.5$ V | | | 100 | μA |
| I_{IH} High-level enable current | $V_{IH} = 2.7$ V | | | 20 | μA |
| I_{IL} Low-level enable current | $V_{IL} = 0.4$ V | | | -360 | μA |
| r_i Differential input resistance | | 4 | | | k Ω |
| r_o Output resistance | | | | 100 | W |
| I_{OS} Short-circuit output current | | -15 | | -85 | mA |
| I_{CC} Supply current | $V_{ID} = 0$, No load | | 17 | 20 | mA |

‡ The algebraic convention, where the more negative limit is designated as minimum, is used in this data sheet for input threshold voltage levels only.

switching characteristics, $V_{CC} = 5$ V, $T_A = 25^\circ\text{C}$

| PARAMETER | TEST CONDITIONS | MIN | TYP | MAX | UNIT |
|--|------------------------------------|-----|-----|-----|------|
| t_{PLH} Propagation delay time, low-to-high-level output | TTL load, See Figure 1, See Note 3 | | 25 | | ns |
| t_{PHL} Propagation delay time, high-to-low-level output | | | 25 | | ns |

NOTE 3: The response time specified is for a 100-mV input step with 5-mV overdrive (105 mV total), and is the interval between the input step function and the instant when the output crosses 2.5 V.



PARAMETER MEASUREMENT INFORMATION

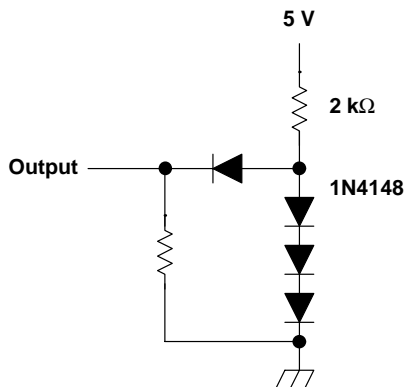

Figure 1. TTL Output Load Circuit

TYPICAL CHARACTERISTICS

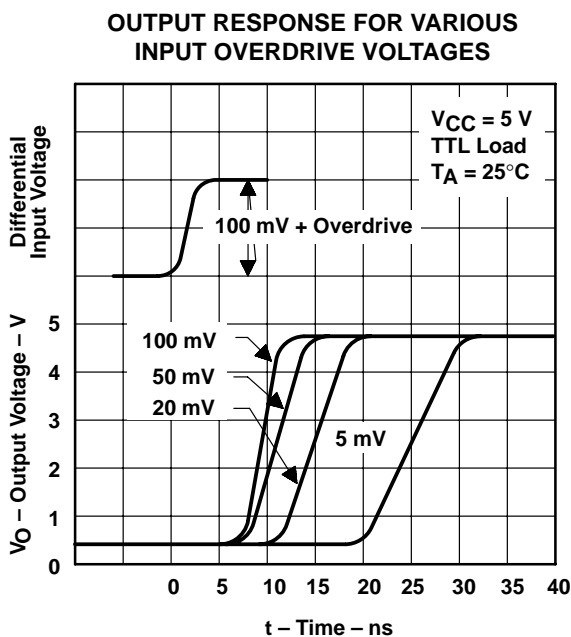

Figure 2

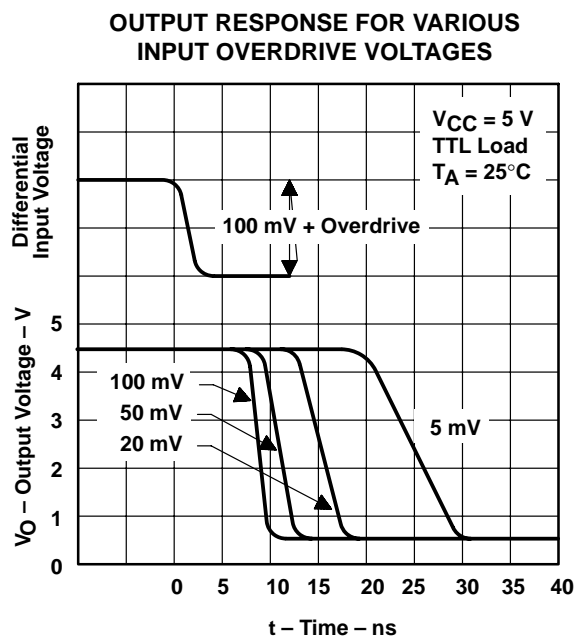

Figure 3

TL712 DIFFERENTIAL COMPARATOR

SLCS002B – JUNE 1983 – REVISED DECEMBER 1992

TYPICAL CHARACTERISTICS

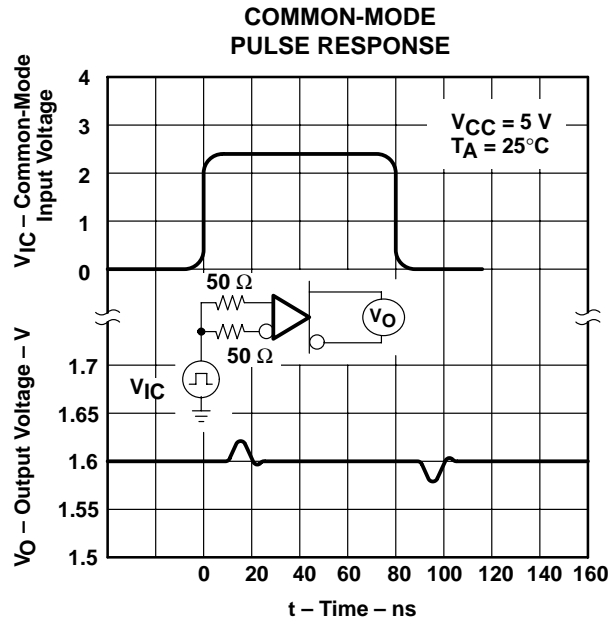

Figure 4

IMPORTANT NOTICE

Texas Instruments (TI) reserves the right to make changes to its products or to discontinue any semiconductor product or service without notice, and advises its customers to obtain the latest version of relevant information to verify, before placing orders, that the information being relied on is current.

TI warrants performance of its semiconductor products and related software to the specifications applicable at the time of sale in accordance with TI's standard warranty. Testing and other quality control techniques are utilized to the extent TI deems necessary to support this warranty. Specific testing of all parameters of each device is not necessarily performed, except those mandated by government requirements.

Certain applications using semiconductor products may involve potential risks of death, personal injury, or severe property or environmental damage ("Critical Applications").

TI SEMICONDUCTOR PRODUCTS ARE NOT DESIGNED, INTENDED, AUTHORIZED, OR WARRANTED TO BE SUITABLE FOR USE IN LIFE-SUPPORT APPLICATIONS, DEVICES OR SYSTEMS OR OTHER CRITICAL APPLICATIONS.

Inclusion of TI products in such applications is understood to be fully at the risk of the customer. Use of TI products in such applications requires the written approval of an appropriate TI officer. Questions concerning potential risk applications should be directed to TI through a local SC sales office.

In order to minimize risks associated with the customer's applications, adequate design and operating safeguards should be provided by the customer to minimize inherent or procedural hazards.

TI assumes no liability for applications assistance, customer product design, software performance, or infringement of patents or services described herein. Nor does TI warrant or represent that any license, either express or implied, is granted under any patent right, copyright, mask work right, or other intellectual property right of TI covering or relating to any combination, machine, or process in which such semiconductor products or services might be or are used.