

TL592B DIFFERENTIAL VIDEO AMPLIFIER

SLFS001A – JUNE 1985 – REVISED APRIL 1988

- Adjustable Gain to 400 Typ
- No Frequency Compensation Required
- Low Noise . . . 3 μ V Typ V_n

description

This device is a monolithic two-stage video amplifier with differential inputs and differential outputs. It features internal series-shunt feedback that provides wide bandwidth, low phase distortion, and excellent gain stability. Emitter-follower outputs enable the device to drive capacitive loads. All stages are current-source biased to obtain high common-mode and supply-voltage rejection ratios.

The differential gain is typically 400 when the gain adjust pins are connected together, or amplification may be adjusted for near 0 to 400 by the use of a single external resistor connected between the gain adjustment pins A and B. No external frequency-compensating components are required for any gain option.

The device is particularly useful in magnetic-tape or disk-file systems using phase or NRZ encoding and in high-speed thin-film or plated-wire memories. Other applications include general-purpose video and pulse amplifiers.

The device achieves low equivalent noise voltage through special processing and a new circuit layout incorporating input transistors with low base resistance.

The TL592B is characterized for operation from 0°C to 70°C.

D8† OR P PACKAGE
(TOP VIEW)

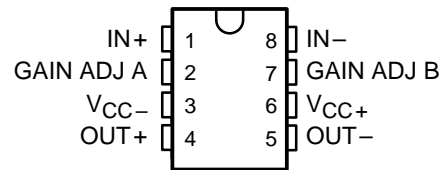

D14† OR N PACKAGE
(TOP VIEW)

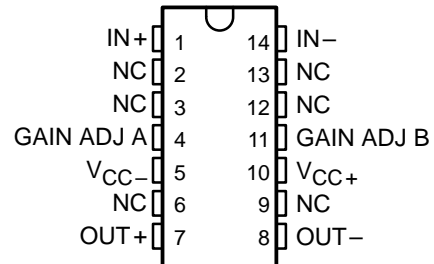

† D8 and D14 are the codes to differentiate the 8-pin and 14-pin versions, respectively.

symbol

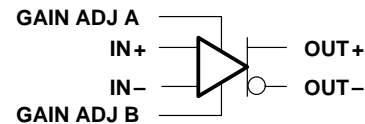

TL592B DIFFERENTIAL VIDEO AMPLIFIER

SLFS001A – JUNE 1985 – REVISED APRIL 1988

schematic

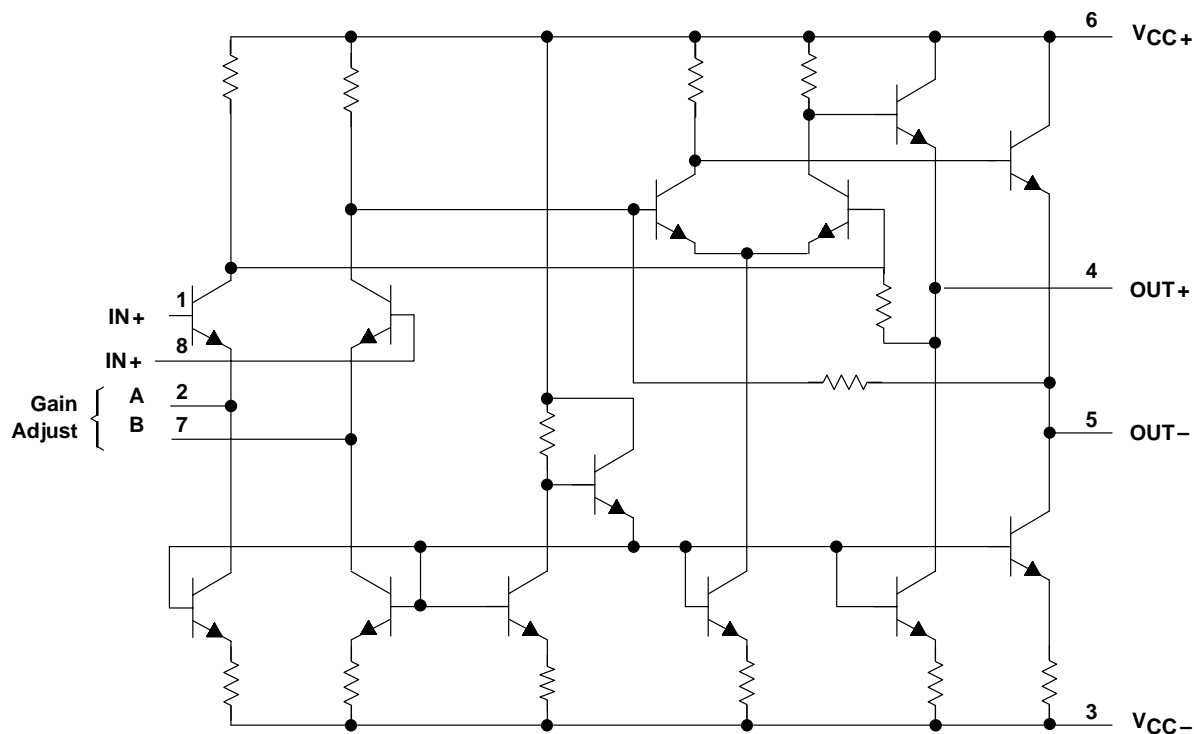

Pin numbers are for D8 and P packages.

absolute maximum ratings over operating free-air temperature (unless otherwise noted)

Supply voltage, V_{CC+} (see Note 1)	8 V
Supply voltage, V_{CC-}	-8 V
Differential input voltage	± 5 V
Voltage range, any input	V_{CC+} to V_{CC-}
Output current	10 mA
Continuous total power dissipation	See Dissipation Rating Table
Operating free-air temperature range	0°C to 70°C
Storage temperature range	-65°C to 150°C
Lead temperature 1,6 mm (1/16 inch) from case for 10 seconds	260°C

NOTES: 1. All voltage values except differential input voltages are with respect to the midpoint between V_{CC+} and V_{CC-} .

DISSIPATION RATING TABLE

PACKAGE	$T_A \leq 25^\circ\text{C}$ POWER RATING	DERATING FACTOR	DERATE ABOVE T_A	$T_A = 70^\circ\text{C}$ POWER RATING
D8	530 mW	5.8 mW/°C	59°C	464 mW
D14	530 mW	N/A	N/A	530 mW
N	530 mW	N/A	N/A	530 mW
P	530 mW	N/A	N/A	530 mW

TL592B DIFFERENTIAL VIDEO AMPLIFIER

SLFS001A – JUNE 1985 – REVISED APRIL 1988

recommended operating conditions

	MIN	NOM	MAX	UNIT
Supply voltage, V_{CC+}	3	6	8	V
Supply voltage, V_{CC-}	-3	-6	-8	V
Operating free-air temperature, T_A	0		70	°C

electrical characteristics at specified free-air temperature, $V_{CC\pm} = \pm 6$ V, $R_L = 2$ k Ω (unless otherwise noted)

PARAMETER		TEST FIGURE	TEST CONDITION†	T_A	MIN	TYP	MAX	UNIT
A_{VD}	Large-signal differential voltage amplification	1	$V_{OPP} = 3$ V, $R_L = 2$ k Ω , $R_{AB} = 0$	25°C	300	400	500	V/V
				0°C to 70°C	250		600	
A_{VD2}	Large-signal differential voltage amplification	1	$V_{OPP} = 3$ V, $R_L = 2$ k Ω , $R_{AB} = 1$ k Ω	25°C		13		V/V
BW	Bandwidth (-3 dB)	2	$V_{OPP} = 1$ V, $R_{AB} = 0$	25°C		50		MHz
I_{IO}	Input offset current			25°C		0.4	5	μ A
				0°C to 70°C			6	
I_{IB}	Input bias current			25°C		9	30	μ A
				0°C to 70°C			40	
V_{ICR}	Common-mode input voltage range	3		25°C	± 1			V
				0°C to 70°C	± 1			
V_{OC}	Common-mode output voltage	1	$R_L = \infty$	25°C	2.4	2.9	3.4	V
V_{OO}	Output offset voltage	1	$V_{ID} = 0$, $R_{AB} = \infty$, $R_L = \infty$	25°C		0.35	0.75	V
				0°C to 70°C			1.5	
V_{OPP}	Peak-to-peak output voltage swing	1	$R_L = 2$ k Ω , $R_{AB} = 0$	25°C	3	4		V
				0°C to 70°C	2.8			
r_i	Input resistance		$V_{OD} = 1$ V, $R_{AB} = 0$	25°C		4		k Ω
				0°C to 70°C		3.6		
r_o	Output resistance			0°C to 70°C			30	Ω
C_i	Input capacitance			25°C		5		pF
$CMRR$	Common-mode rejection ratio	3	$V_{IC} = \pm 1$ V, $R_{AB} = 0$	f = 100 kHz	25°C	60	86	dB
				f = 5 MHz		60		
				f = 100 kHz	0°C to 70°C	50		
				f = 5 MHz		60		
k_{SVR}	Supply voltage rejection ratio ($\Delta V_{CC+}/\Delta V_{IO}$)	4	$\Delta V_{CC+} = \pm 0.5$ V, $\Delta V_{CC-} = \pm 0.5$ V, $R_{AB} = 0$	25°C	50	70		dB
				0°C to 70°C	50			
V_n	Broadband equivalent input noise voltage	4	$BW = 1$ kHz to 10 MHz	25°C		3		μ V
t_{pd}	Propagation delay time	2	$\Delta V_O = 1$ V	25°C		7.5		ns
t_r	Rise time	2	$\Delta V_O = 1$ V	25°C		10.5		ns
$I_{sink(max)}$	Maximum output sink current		$V_{ID} = 1$ V, $V_O = 3$ V		3	4		mA
I_{CC}	Supply current		No load, No signal	25°C		18	24	mA
				0°C to 70°C			27	

† R_{AB} is the gain-adjustment resistor connected between gain-adjust pins A and B. If not specified for a particular parameter, its value is irrelevant to that parameter.



TL592B DIFFERENTIAL VIDEO AMPLIFIER

SLFS001A – JUNE 1985 – REVISED APRIL 1988

PARAMETER MEASUREMENT INFORMATION

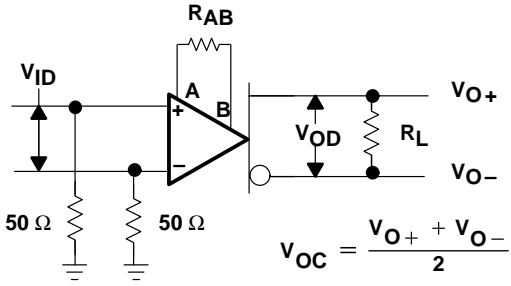

Figure 1

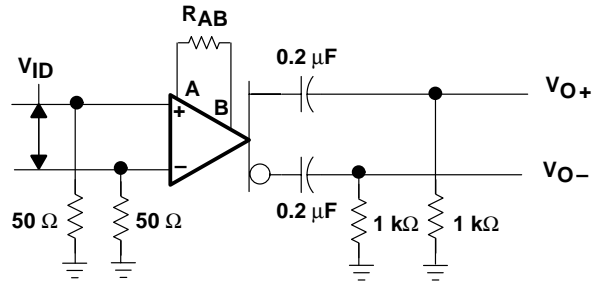

Figure 2

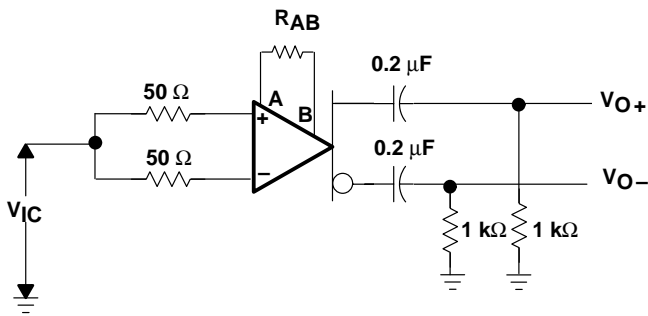

Figure 3

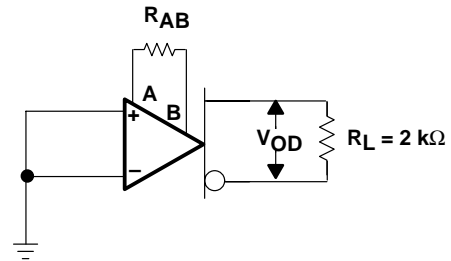

Figure 4

TYPICAL CHARACTERISTICS

LARGE-SIGNAL DIFFERENTIAL
VOLTAGE AMPLIFICATION
vs
SUPPLY VOLTAGE

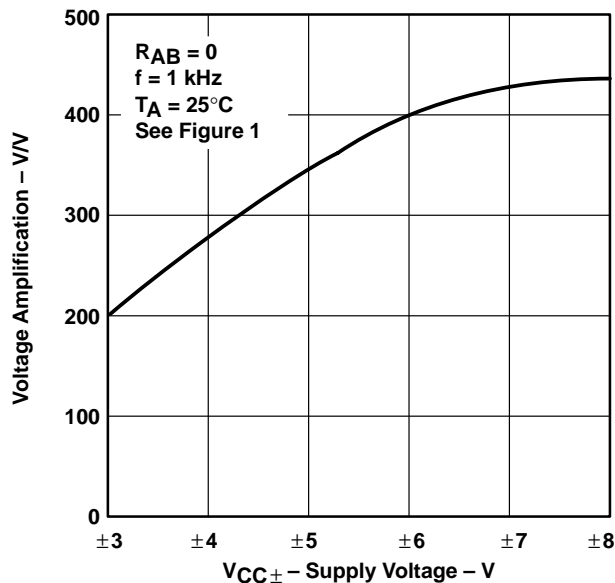

Figure 5

LARGE-SIGNAL DIFFERENTIAL
VOLTAGE AMPLIFICATION
vs
GAIN-ADJUSTMENT RESISTANCE

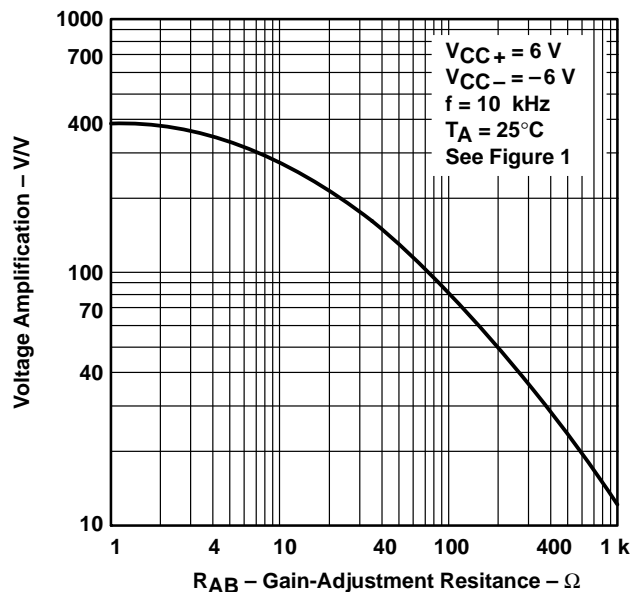

Figure 6

SUPPLY CURRENT
vs
SUPPLY VOLTAGE

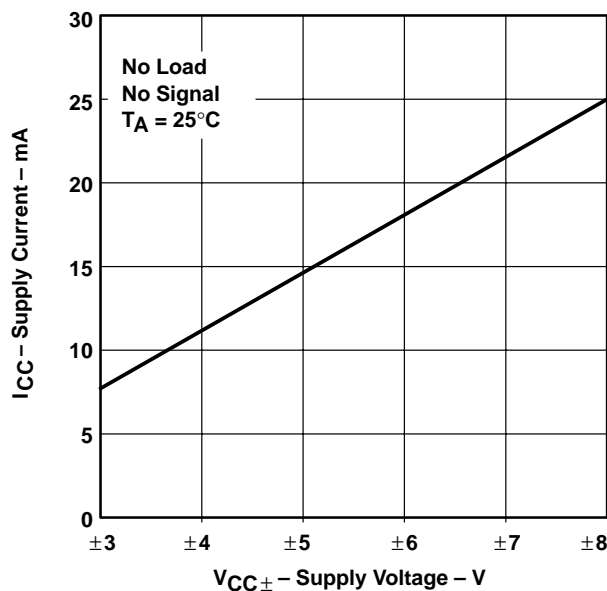

Figure 7

IMPORTANT NOTICE

Texas Instruments (TI) reserves the right to make changes to its products or to discontinue any semiconductor product or service without notice, and advises its customers to obtain the latest version of relevant information to verify, before placing orders, that the information being relied on is current.

TI warrants performance of its semiconductor products and related software to the specifications applicable at the time of sale in accordance with TI's standard warranty. Testing and other quality control techniques are utilized to the extent TI deems necessary to support this warranty. Specific testing of all parameters of each device is not necessarily performed, except those mandated by government requirements.

Certain applications using semiconductor products may involve potential risks of death, personal injury, or severe property or environmental damage ("Critical Applications").

TI SEMICONDUCTOR PRODUCTS ARE NOT DESIGNED, INTENDED, AUTHORIZED, OR WARRANTED TO BE SUITABLE FOR USE IN LIFE-SUPPORT APPLICATIONS, DEVICES OR SYSTEMS OR OTHER CRITICAL APPLICATIONS.

Inclusion of TI products in such applications is understood to be fully at the risk of the customer. Use of TI products in such applications requires the written approval of an appropriate TI officer. Questions concerning potential risk applications should be directed to TI through a local SC sales office.

In order to minimize risks associated with the customer's applications, adequate design and operating safeguards should be provided by the customer to minimize inherent or procedural hazards.

TI assumes no liability for applications assistance, customer product design, software performance, or infringement of patents or services described herein. Nor does TI warrant or represent that any license, either express or implied, is granted under any patent right, copyright, mask work right, or other intellectual property right of TI covering or relating to any combination, machine, or process in which such semiconductor products or services might be or are used.