

TPIC5203 2-CHANNEL INDEPENDENT GATE-PROTECTED POWER DMOS ARRAY

SLIS040 – SEPTEMBER 1994

- Low $r_{DS(on)}$. . . 0.26 Ω Typ
- High Voltage Output . . . 60 V
- Extended ESD Capability . . . 4000 V
- Pulsed Current . . . 8 A Per Channel
- Fast Commutation Speed

**D PACKAGE
(TOP VIEW)**

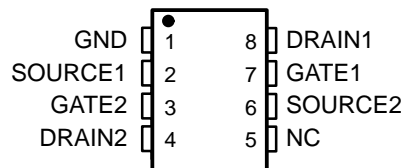

NC – No internal connection

description

The TPIC5203 is a monolithic gate-protected power DMOS array that consists of two independent electrically isolated N-channel enhancement-mode DMOS transistors. Each transistor features integrated high-current zener diodes (Z_{CXa} and Z_{CXb}) to prevent gate damage in the event that an overstress condition occurs. These zener diodes also provide up to 4000 V of ESD protection when tested using the human-body model of a 100-pF capacitor in series with a 1.5-k Ω resistor.

The TPIC5203 is offered in a standard eight-pin small-outline surface-mount (D) package and is characterized for operation over the case temperature range of -40°C to 125°C .

schematic

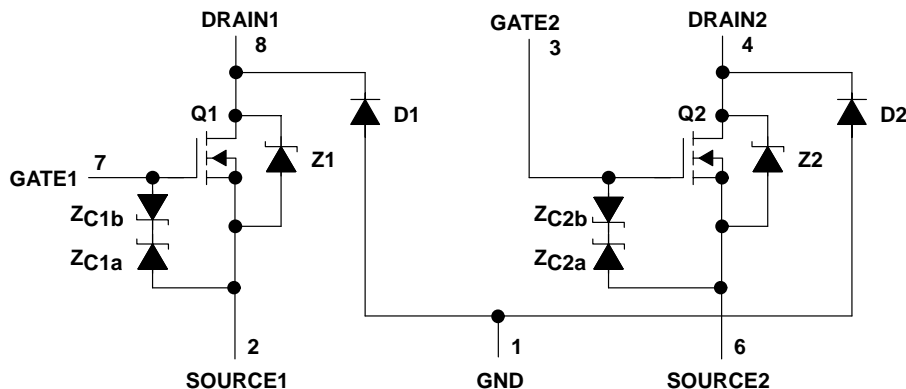

NOTE: For correct operation, no terminal pin may be taken below GND.

TPIC5203

2-CHANNEL INDEPENDENT GATE-PROTECTED POWER DMOS ARRAY

SLIS040 – SEPTEMBER 1994

absolute maximum ratings over operating case temperature range (unless otherwise noted)†

Drain-to-source voltage, V_{DS}	60 V
Source-to-GND voltage (Q1, Q2)	100 V
Drain-to-GND voltage (Q1, Q2)	100 V
Gate-to-source voltage range, V_{GS}	-9 V to 18 V
Continuous drain current, each output, $T_C = 25^\circ\text{C}$	1.6 A
Continuous source-to-drain diode current, $T_C = 25^\circ\text{C}$	1.6 A
Pulsed drain current, each output, I_{max} , $T_C = 25^\circ\text{C}$ (see Note 1 and Figure 15)	8 A
Continuous gate-to-source zener diode current, $T_C = 25^\circ\text{C}$	± 50 mA
Pulsed gate-to-source zener-diode current, $T_C = 25^\circ\text{C}$	± 500 mA
Single-pulse avalanche energy, E_{AS} , $T_C = 25^\circ\text{C}$ (see Figures 4, 15, and 16)	21.6 mJ
Continuous total dissipation, $T_C = 25^\circ\text{C}$ (see Figure 15)	962 mW
Operating virtual junction temperature range, T_J	-40°C to 150°C
Operating case temperature range, T_C	-40°C to 125°C
Storage temperature range, T_{stg}	-65°C to 150°C
Lead temperature 1,6 mm (1/16 inch) from case for 10 seconds	260°C

† Stresses beyond those listed under "absolute maximum ratings" may cause permanent damage to the device. These are stress ratings only, and functional operation of the device at these or any other conditions beyond those indicated under "recommended operating conditions" is not implied. Exposure to absolute-maximum-rated conditions for extended periods may affect device reliability.

NOTE 1: Pulse duration = 10 ms, duty cycle = 2%

electrical characteristics, $T_C = 25^\circ\text{C}$ (unless otherwise noted)

PARAMETER		TEST CONDITIONS		MIN	TYP	MAX	UNIT
$V_{(BR)DSX}$	Drain-to-source breakdown voltage	$I_D = 250 \mu\text{A}$,	$V_{GS} = 0$	60			V
$V_{GS(th)}$	Gate-to-source threshold voltage	$I_D = 1 \text{ mA}$, See Figure 5	$V_{DS} = V_{GS}$,	1.5	2.05	2.2	V
$V_{(BR)GS}$	Gate-to-source breakdown voltage	$I_{GS} = 250 \mu\text{A}$		18			V
$V_{(BR)SG}$	Source-to-gate breakdown voltage	$I_{SG} = 250 \mu\text{A}$		9			V
$V_{(BR)}$	Reverse drain-to-GND breakdown voltage (across D1, D2)	Drain-to-GND current = $250 \mu\text{A}$		100			V
$V_{DS(on)}$	Drain-to-source on-state voltage	$I_D = 1.6 \text{ A}$, See Notes 2 and 3	$V_{GS} = 10 \text{ V}$,		0.42	0.5	V
$V_{F(SD)}$	Forward on-state voltage, source-to-drain	$I_S = 1.6 \text{ A}$, $V_{GS} = 0$ (Z1, Z2), See Notes 2 and 3 and Figure 12			1	1.2	V
V_F	Forward on-state voltage, GND-to-drain	$I_D = 1.6 \text{ A}$ (D1, D2), See Notes 2 and 3			5		V
I_{DSS}	Zero-gate-voltage drain current	$V_{DS} = 48 \text{ V}$, $V_{GS} = 0$	$T_C = 25^\circ\text{C}$	0.05	1		μA
			$T_C = 125^\circ\text{C}$	0.5	10		
I_{GSSF}	Forward-gate current, drain short circuited to source	$V_{GS} = 15 \text{ V}$,	$V_{DS} = 0$		20	200	nA
I_{GSSR}	Reverse-gate current, drain short circuited to source	$V_{SG} = 5 \text{ V}$,	$V_{DS} = 0$		10	100	nA
I_{lkg}	Leakage current, drain-to-GND	$V_{DGND} = 48 \text{ V}$	$T_C = 25^\circ\text{C}$	0.05	1		μA
			$T_C = 125^\circ\text{C}$	0.5	10		
$r_{DS(on)}$	Static drain-to-source on-state resistance	$V_{GS} = 10 \text{ V}$, $I_D = 1.6 \text{ A}$, See Notes 2 and 3 and Figures 6 and 7	$T_C = 25^\circ\text{C}$	0.26	0.31		Ω
			$T_C = 125^\circ\text{C}$	0.41	0.45		
g_{fs}	Forward transconductance	$V_{DS} = 15 \text{ V}$, See Notes 2 and 3 and Figure 9	$I_D = 800 \text{ mA}$,	1.5	1.83		S
C_{iss}	Short-circuit input capacitance, common source			150	275		pF
C_{oss}	Short-circuit output capacitance, common source	$V_{DS} = 25 \text{ V}$,	$V_{GS} = 0$,	100	150		
C_{rss}	Short-circuit reverse transfer capacitance, common source	$f = 1 \text{ MHz}$,	See Figure 11	40	125		

NOTES: 2. Technique should limit $T_J - T_C$ to 10°C maximum.
 3. These parameters are measured with voltage-sensing contacts separate from the current-carrying contacts.

source-to-drain and GND-to-drain diode characteristics, $T_C = 25^\circ\text{C}$

PARAMETER		TEST CONDITIONS		MIN	TYP	MAX	UNIT
t_{rr}	Reverse-recovery time	$I_S = 800 \text{ mA}$, $V_{GS} = 0$, See Figures 1 and 14	$V_{DS} = 48 \text{ V}$, $di/dt = 100 \text{ A}/\mu\text{s}$,	Z1 and Z2	50		ns
				D1 and D2	265		
Q_{RR}	Total diode charge			Z1 and Z2	63		nC
				D1 and D2	1240		

TPIC5203
2-CHANNEL INDEPENDENT GATE-PROTECTED
POWER DMOS ARRAY

SLIS040 – SEPTEMBER 1994

resistive-load switching characteristics, $T_C = 25^\circ\text{C}$

PARAMETER	TEST CONDITIONS	MIN	TYP	MAX	UNIT
$t_{d(on)}$ Turn-on delay time	$V_{DD} = 25\text{ V}$, $R_L = 30\ \Omega$, $t_{en} = 10\text{ ns}$, $t_{dis} = 10\text{ ns}$, See Figure 2		25	50	ns
$t_{d(off)}$ Turn-off delay time			27	50	
t_r Rise time			15	30	
t_f Fall time			7	15	
Q_g Total gate charge	$V_{DS} = 48\text{ V}$, $I_D = 0.8\text{ A}$, $V_{GS} = 10\text{ V}$, See Figure 3		4.7	5.9	nC
$Q_{gs(th)}$ Threshold gate-to-source charge			0.5	0.6	
Q_{gd} Gate-to-drain charge			1.9	2.4	
L_D Internal drain inductance			5		nH
L_S Internal source inductance			5		
R_g Internal gate resistance			0.25		Ω

thermal resistance

PARAMETER	TEST CONDITIONS	MIN	TYP	MAX	UNIT
$R_{\theta JA}$ Junction-to-ambient thermal resistance	See Notes 4 and 7		130		$^\circ\text{C/W}$
$R_{\theta JB}$ Junction-to-board thermal resistance	See Notes 5 and 7		79		
$R_{\theta JP}$ Junction-to-pin thermal resistance	See Notes 6 and 7		34		

- NOTES: 4. Package mounted on an FR4 printed-circuit board with no heatsink
5. Package mounted on a 24 inch², 4-layer FR4 printed-circuit board
6. Package mounted in intimate contact with infinite heatsink
7. All outputs with equal power

PARAMETER MEASUREMENT INFORMATION

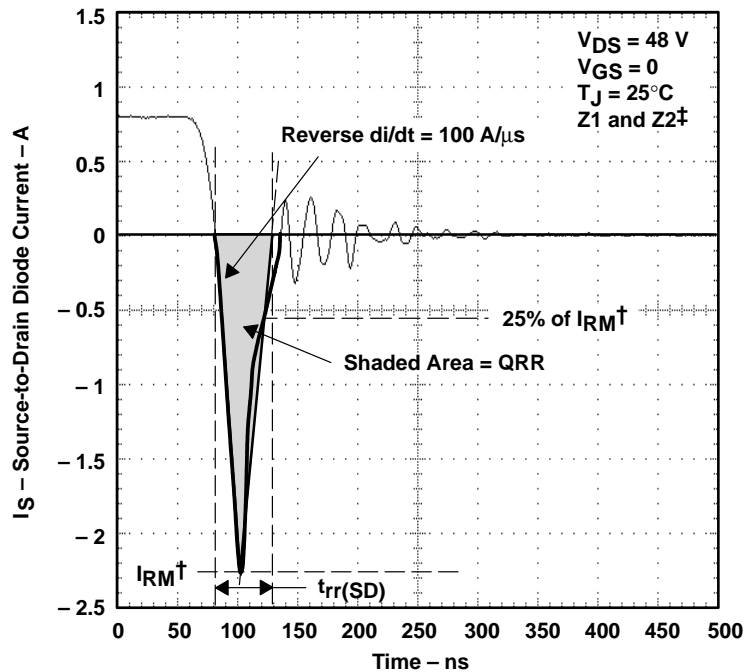

$^\dagger I_{RM}$ = maximum recovery current
 ‡ The above waveform is representative of D1 and D2 in shape only.

Figure 1. Reverse-Recovery-Current Waveform of Source-to-Drain Diode



PARAMETER MEASUREMENT INFORMATION

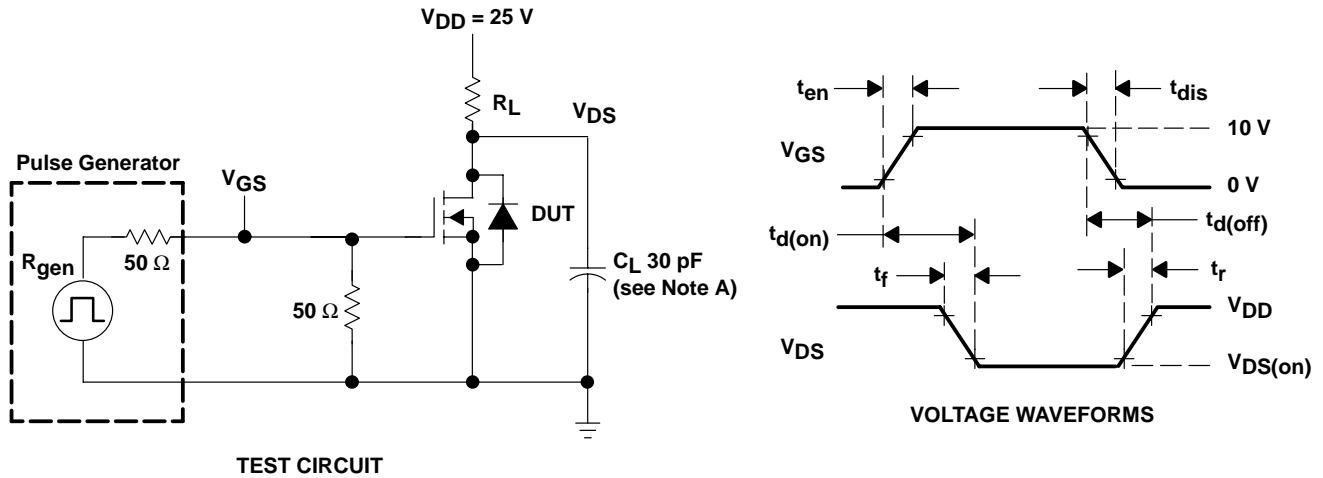

NOTE A: C_L includes probe and jig capacitance.

Figure 2. Resistive-Switching Test Circuit and Voltage Waveforms

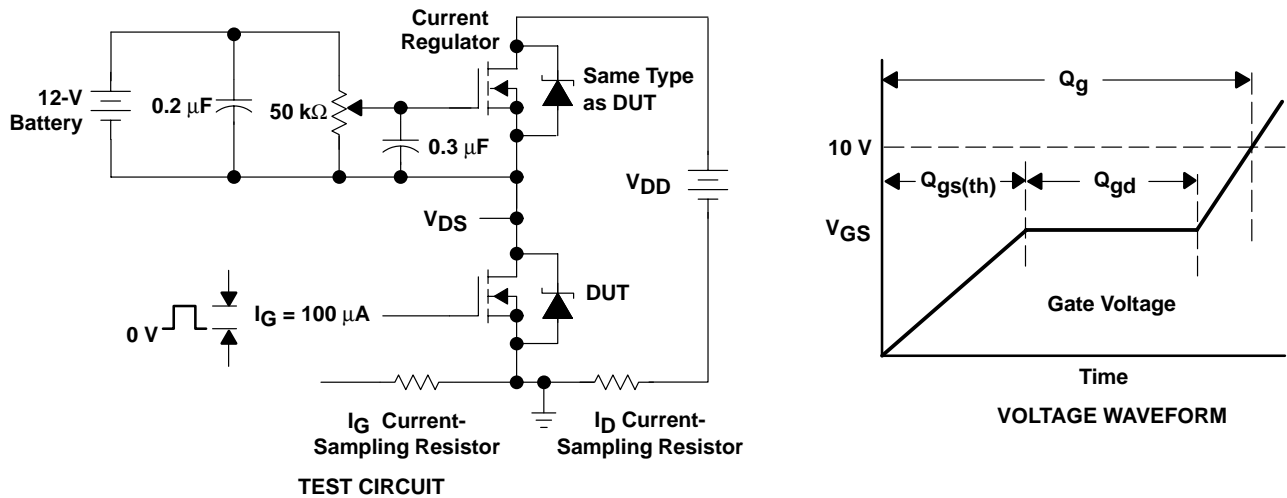
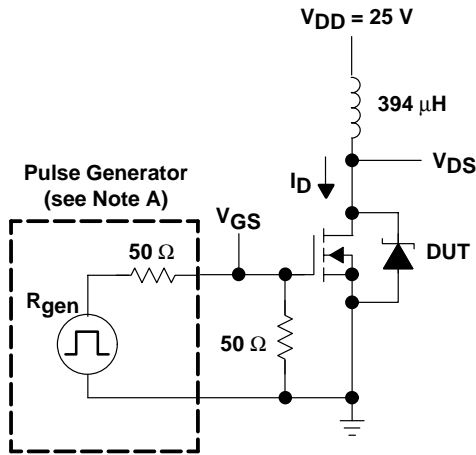

Figure 3. Gate-Charge Test Circuit and Voltage Waveform

TPIC5203
2-CHANNEL INDEPENDENT GATE-PROTECTED
POWER DMOS ARRAY

SLIS040 – SEPTEMBER 1994

PARAMETER MEASUREMENT INFORMATION



TEST CIRCUIT

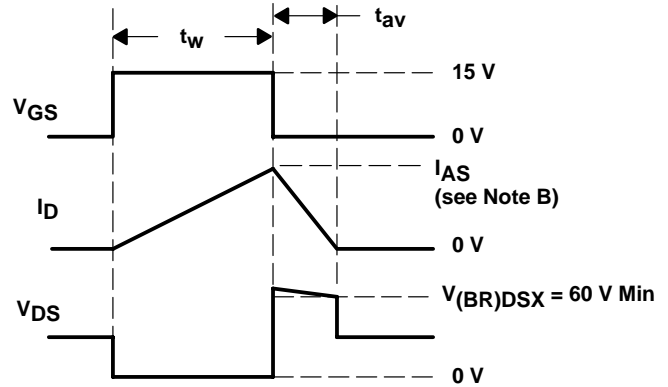

VOLTAGE AND CURRENT WAVEFORMS

- NOTES: A. The pulse generator has the following characteristics: $t_r \leq 10$ ns, $t_f \leq 10$ ns, $Z_O = 50 \Omega$.
 B. Input pulse duration (t_w) is increased until peak current $I_{AS} = 8$ A.

Energy test level is defined as $E_{AS} = \frac{I_{AS} \times V_{(BR)DSX} \times t_{av}}{2} = 21.6$ mJ.

Figure 4. Single-Pulse Avalanche Energy Test Circuit and Waveforms

TYPICAL CHARACTERISTICS

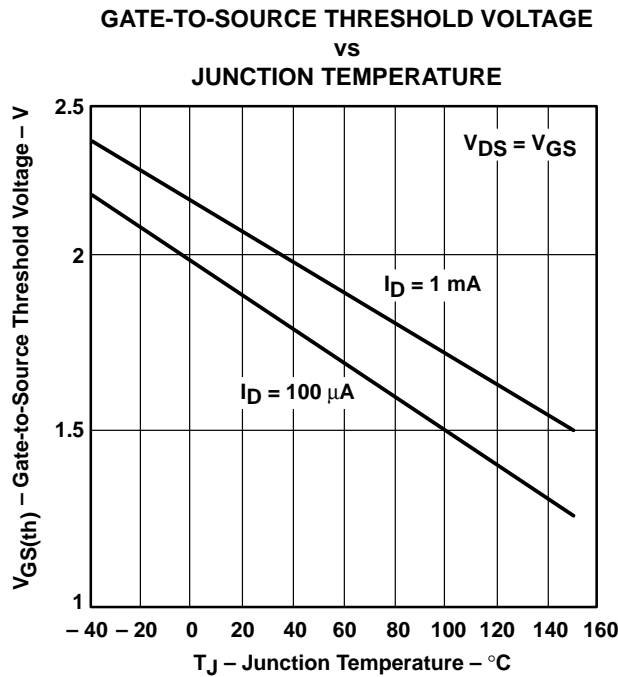

Figure 5

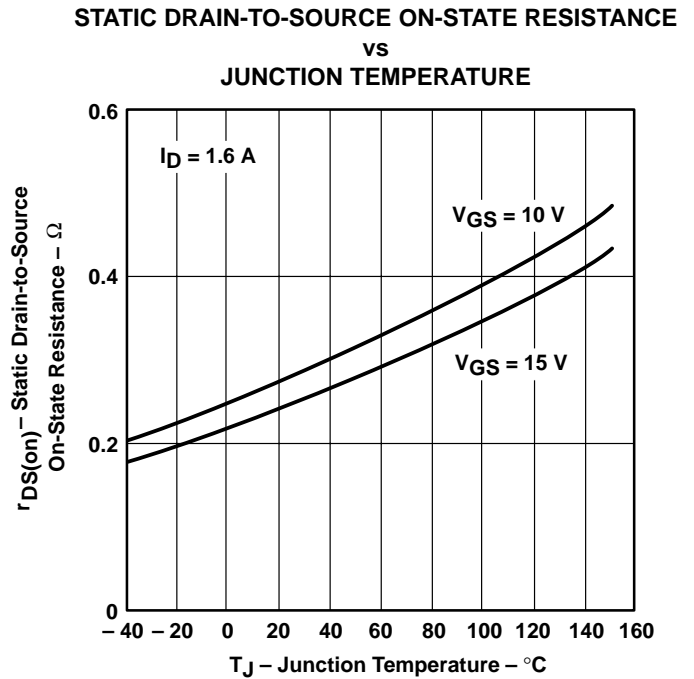

Figure 6



TYPICAL CHARACTERISTICS

STATIC DRAIN-TO-SOURCE ON-STATE RESISTANCE
 vs
DRAIN CURRENT

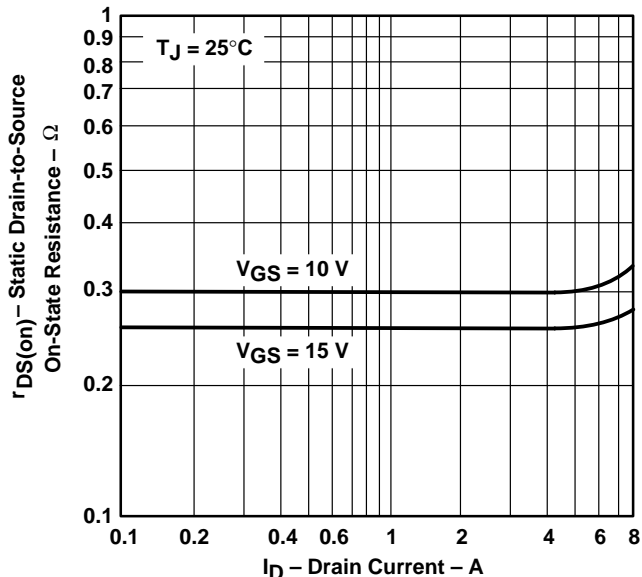

Figure 7

DRAIN CURRENT
 vs
DRAIN-TO-SOURCE VOLTAGE

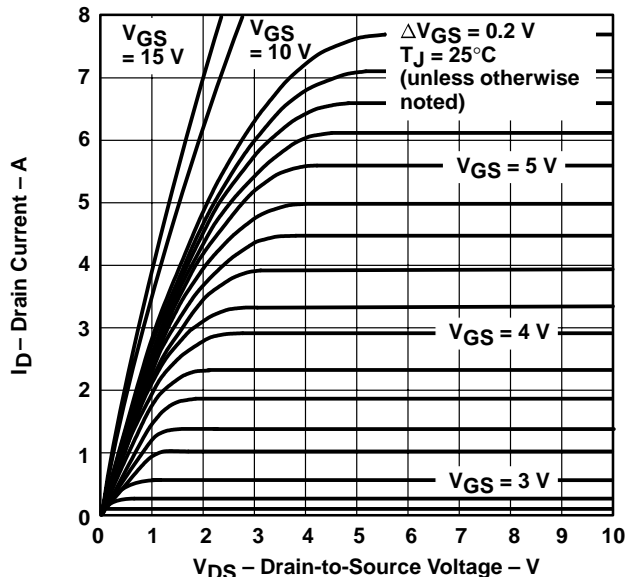

Figure 8

DISTRIBUTION OF
FORWARD TRANSCONDUCTANCE

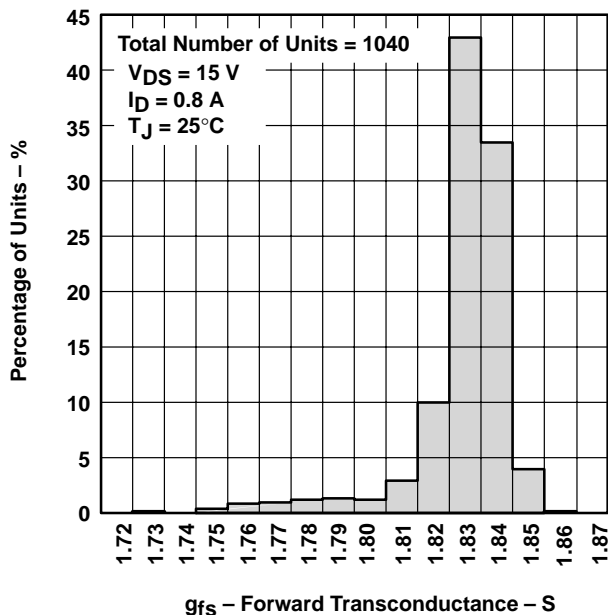

Figure 9

DRAIN CURRENT
 vs
GATE-TO-SOURCE VOLTAGE

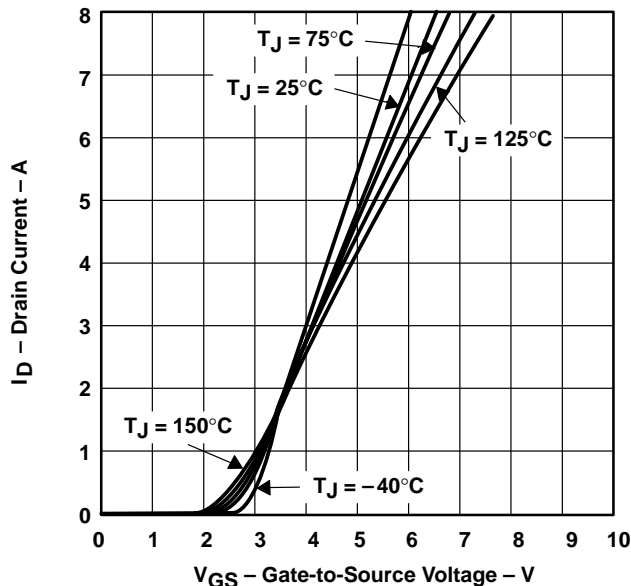

Figure 10

TPIC5203
2-CHANNEL INDEPENDENT GATE-PROTECTED
POWER DMOS ARRAY

SLIS040 – SEPTEMBER 1994

TYPICAL CHARACTERISTICS

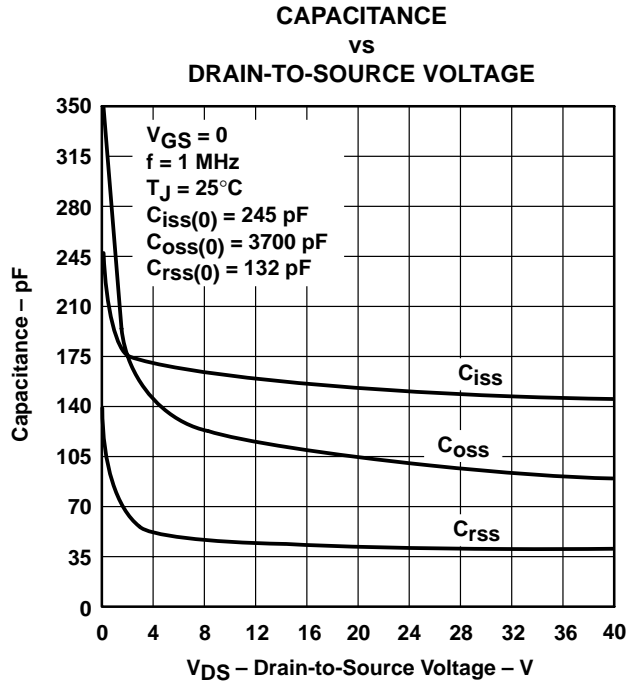

Figure 11

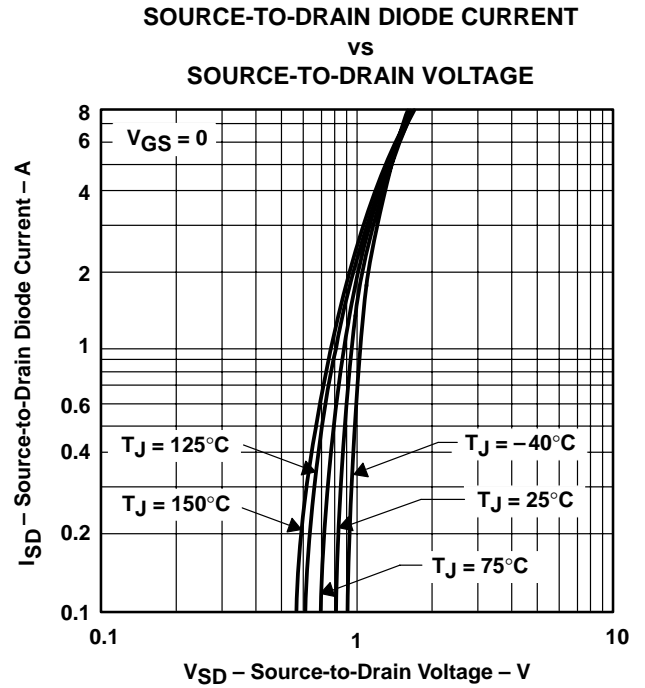

Figure 12

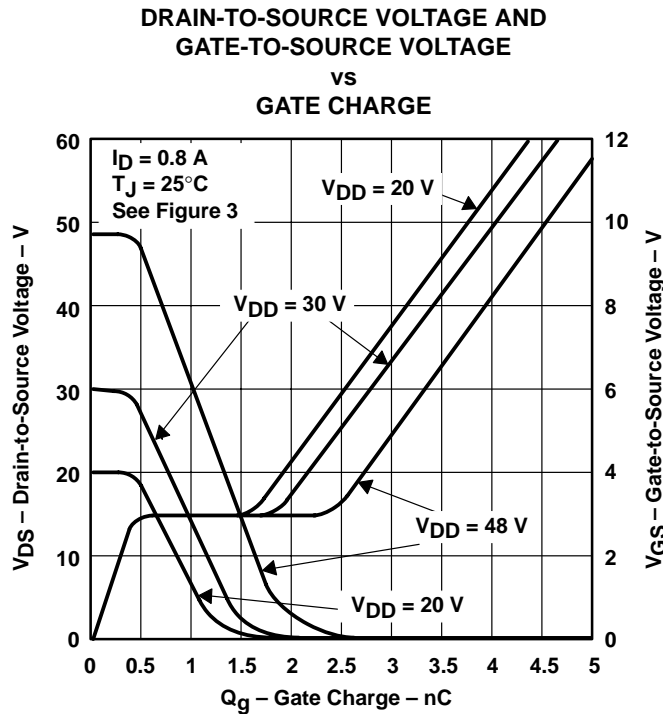

Figure 13

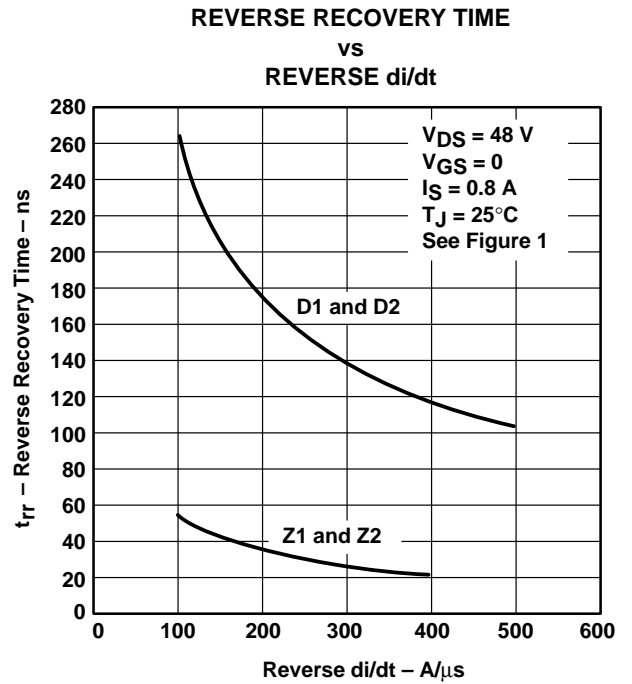
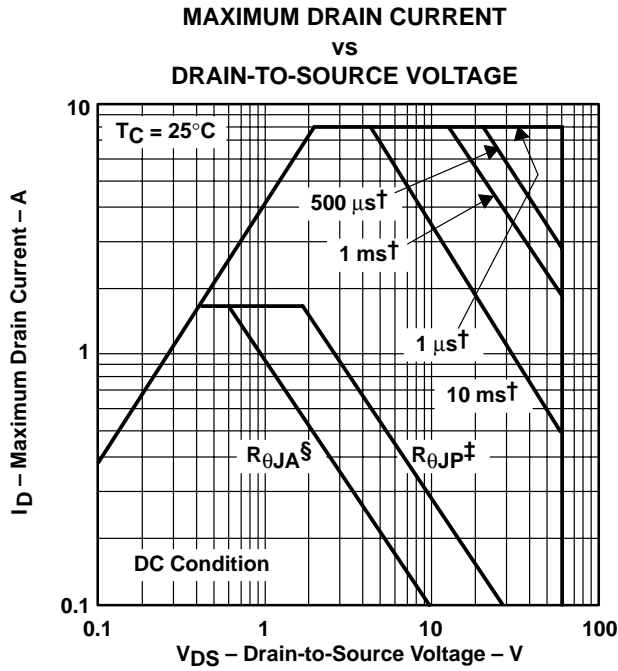

Figure 14

THERMAL INFORMATION



† Less than 2% duty cycle
 ‡ Device mounted in intimate contact with infinite heatsink.
 § Device mounted on FR4 printed circuit board with no heatsink.

Figure 15

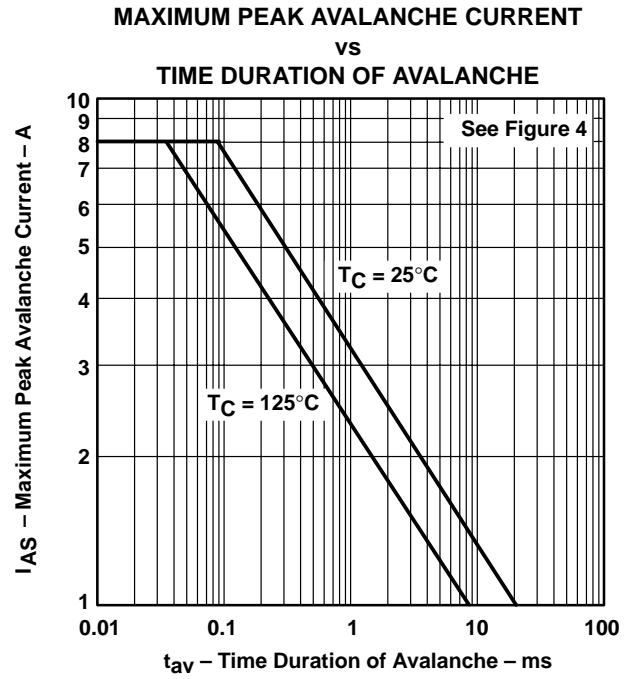

Figure 16

TPIC5203
2-CHANNEL INDEPENDENT GATE-PROTECTED
POWER DMOS ARRAY

SLIS040 – SEPTEMBER 1994

THERMAL INFORMATION

D PACKAGE†
JUNCTION-TO-BOARD THERMAL RESISTANCE
vs
PULSE DURATION

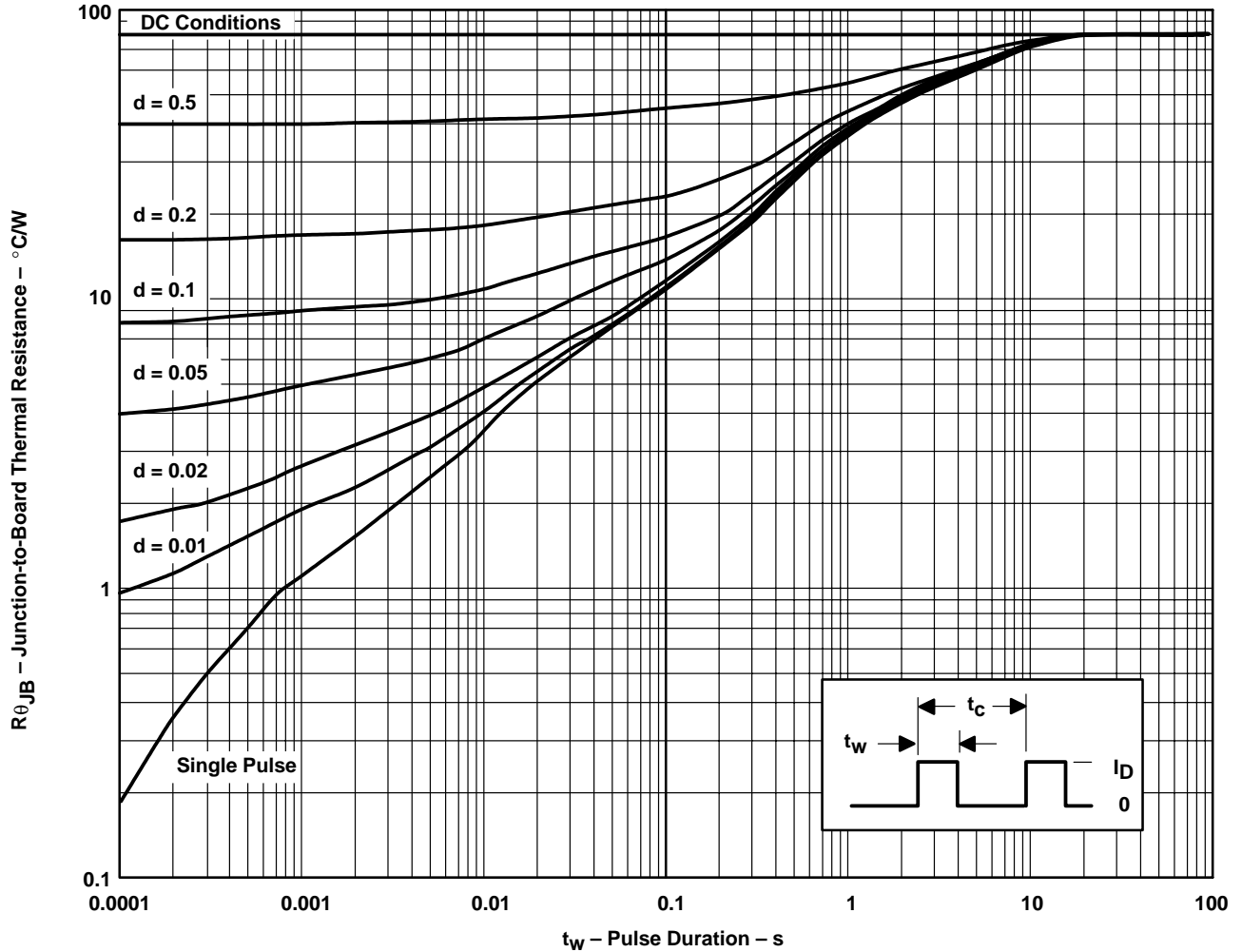

† Device mounted on 24 in², 4-layer FR4 printed-circuit board with no heatsink

NOTE A. $Z_{\theta JB}(t) = r(t)R_{\theta JB}$
 t_w = pulse duration
 t_c = cycle time
 d = duty cycle = t_w/t_c

Figure 17

IMPORTANT NOTICE

Texas Instruments (TI) reserves the right to make changes to its products or to discontinue any semiconductor product or service without notice, and advises its customers to obtain the latest version of relevant information to verify, before placing orders, that the information being relied on is current.

TI warrants performance of its semiconductor products and related software to the specifications applicable at the time of sale in accordance with TI's standard warranty. Testing and other quality control techniques are utilized to the extent TI deems necessary to support this warranty. Specific testing of all parameters of each device is not necessarily performed, except those mandated by government requirements.

Certain applications using semiconductor products may involve potential risks of death, personal injury, or severe property or environmental damage ("Critical Applications").

TI SEMICONDUCTOR PRODUCTS ARE NOT DESIGNED, INTENDED, AUTHORIZED, OR WARRANTED TO BE SUITABLE FOR USE IN LIFE-SUPPORT APPLICATIONS, DEVICES OR SYSTEMS OR OTHER CRITICAL APPLICATIONS.

Inclusion of TI products in such applications is understood to be fully at the risk of the customer. Use of TI products in such applications requires the written approval of an appropriate TI officer. Questions concerning potential risk applications should be directed to TI through a local SC sales office.

In order to minimize risks associated with the customer's applications, adequate design and operating safeguards should be provided by the customer to minimize inherent or procedural hazards.

TI assumes no liability for applications assistance, customer product design, software performance, or infringement of patents or services described herein. Nor does TI warrant or represent that any license, either express or implied, is granted under any patent right, copyright, mask work right, or other intellectual property right of TI covering or relating to any combination, machine, or process in which such semiconductor products or services might be or are used.