

# SN75ALS164

## OCTAL GENERAL-PURPOSE INTERFACE BUS TRANSCEIVER

SLLS022C – JUNE 1986 – REVISED MAY 1998

- **8-Channel Bidirectional Transceiver**
- **Designed to Implement Control Bus Interface**
- **Designed for Multiple-Controller Systems**
- **High-Speed Advanced Low-Power Schottky Circuitry**
- **Low-Power Dissipation . . . 46 mW Max Per Channel**
- **Fast Propagation Times . . . 20 ns Max**
- **High-Impedance pnp Inputs**
- **Receiver Hysteresis . . . 650 mV Typ**
- **Bus-Terminating Resistors Provided on Driver Outputs**
- **No Loading of Bus When Device Is Powered Down ( $V_{CC} = 0$ )**
- **Power-Up/Power-Down Protection (Glitch Free)**

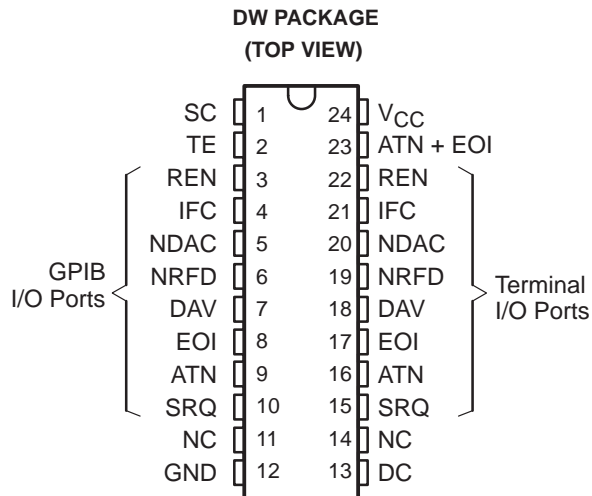

NC – No internal connection

**NOT RECOMMENDED FOR NEW DESIGNS**

### description

The SN75ALS164 eight-channel general-purpose interface bus transceiver is a monolithic, high-speed, advanced low-power Schottky device designed to meet the requirements of IEEE Standard 488-1978. Each transceiver is designed to provide the bus-management and data-transfer signals between operating units of a multiple-controller instrumentation system. When combined with the SN75ALS160 octal bus transceiver, the SN75ALS164 provides the complete 16-wire interface for the IEEE 488 bus.

The SN75ALS164 features eight driver-receiver pairs connected in a front-to-back configuration to form input/output (I/O) ports at both the bus and terminal sides. All outputs are disabled (at the high-impedance state) during  $V_{CC}$  power-up and power-down transitions for glitch-free operation. The direction of data flow through these driver-receiver pairs is determined by the DC, TE, and SC enable signals. The SN75ALS164 is identical to the SN75ALS162 with the addition of an OR gate to help simplify board layouts in several popular applications. The ATN and EOI signals are ORed to provide the ATN + EOI output, which is a standard totem-pole output.

The driver outputs (GPIB I/O ports) feature active bus-terminating resistor circuits designed to provide a high impedance to the bus when supply voltage  $V_{CC}$  is 0. The drivers are designed to handle loads up to 48 mA of sink current. Each receiver features pnp transistor inputs for high input impedance and hysteresis of 400 mV minimum for increased noise immunity. All receivers have 3-state outputs that present a high impedance to the terminal when disabled.

The SN75ALS164 is characterized for operation from 0°C to 70°C.



Please be aware that an important notice concerning availability, standard warranty, and use in critical applications of Texas Instruments semiconductor products and disclaimers thereto appears at the end of this data sheet.

PRODUCTION DATA information is current as of publication date. Products conform to specifications per the terms of Texas Instruments standard warranty. Production processing does not necessarily include testing of all parameters.

**TEXAS  
INSTRUMENTS**

POST OFFICE BOX 655303 • DALLAS, TEXAS 75265

Copyright © 1998, Texas Instruments Incorporated

# SN75ALS164 OCTAL GENERAL-PURPOSE INTERFACE BUS TRANSCEIVER

SLLS022C – JUNE 1986 – REVISED MAY 1998

**CHANNEL IDENTIFICATION TABLE**

NAME	IDENTITY	CLASS
DC TE SC	Direction-Control Talk-Enable System Control	Control
ATN SRQ REN IFC EOI	Attention Service Request Remote Enable Interface Clear End or Identity	Bus Management
ATN+EOI	ATN Logical or EOI	Logic
DAV NDAC NRFD	Data Valid No Data Accepted Not Ready for Data	Data Transfer

## Function Tables

**RECEIVE/TRANSMIT FUNCTION TABLE**

CONTROLS				BUS-MANAGEMENT CHANNELS					DATA-TRANSFER CHANNELS		
SC	DC	TE	ATN†	ATN† (controlled by DC)	SRQ	REN (controlled by SC)	IFC	EOI	DAV	NDAC	NRFD (controlled by TE)
	H	H	H	R	T			T	T	R	R
	H	H	L					R			
	L	L	H	T	R			R	R	T	T
	L	L	L					T			
	H	L	X	R	T			R	R	T	T
	L	H	X	T	R			T	T	R	R
H						T	T				
L						R	R				

H = high level, L = low level, R = receive, T = transmit, X = irrelevant

Direction of data transmission is from the terminal side to the bus side, and the direction of data receiving is from the bus side to the terminal side.

Data transfer is noninverting in both directions.

† ATN is a normal transceiver channel that functions additionally as an internal direction control or talk enable for EOI when the DC and TE inputs are in the same state. When DC and TE are in opposite states, the ATN channel functions as an independent transceiver only.

**ATN + EOI FUNCTION TABLE**

INPUTS		OUTPUT ATN + EOI
ATN	EOI	
H	X	H
X	H	H
L	L	L

# SN75ALS164 OCTAL GENERAL-PURPOSE INTERFACE BUS TRANSCEIVER

SLLS022C – JUNE 1986 – REVISED MAY 1998

**logic symbol†**

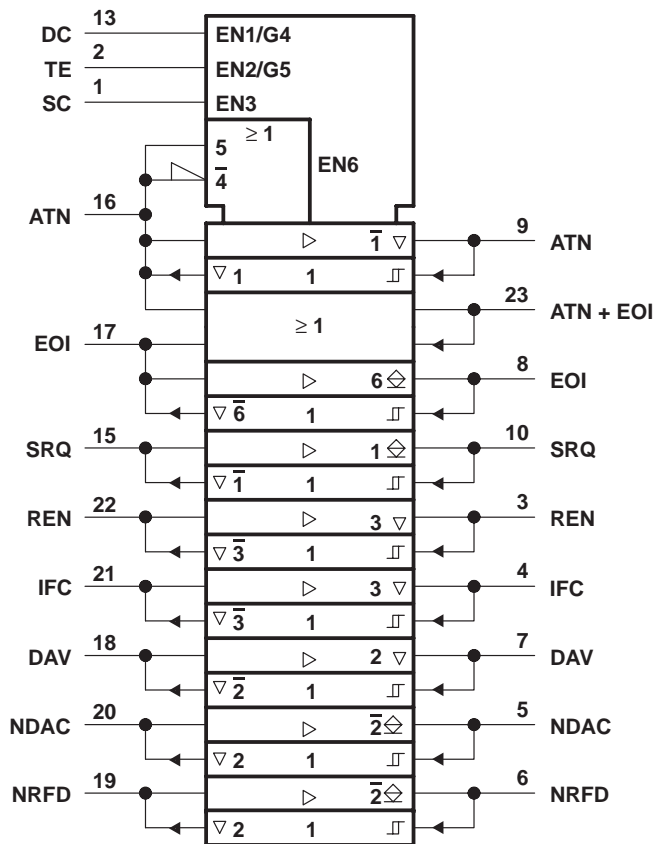

† This symbol is in accordance with ANSI/IEEE Std 91-1984 and IEC Publication 617-12.

▽ Designates 3-state outputs

◇ Designates passive-pullup outputs

**logic diagram (positive logic)**

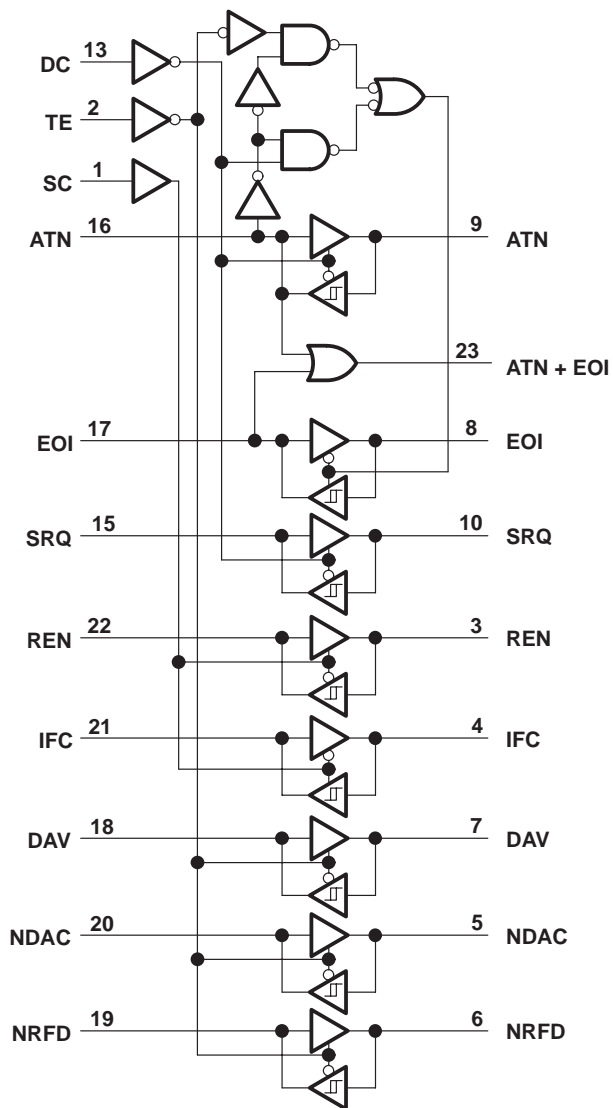

# SN75ALS164 OCTAL GENERAL-PURPOSE INTERFACE BUS TRANSCEIVER

SLLS022C – JUNE 1986 – REVISED MAY 1998

## schematics of inputs and outputs

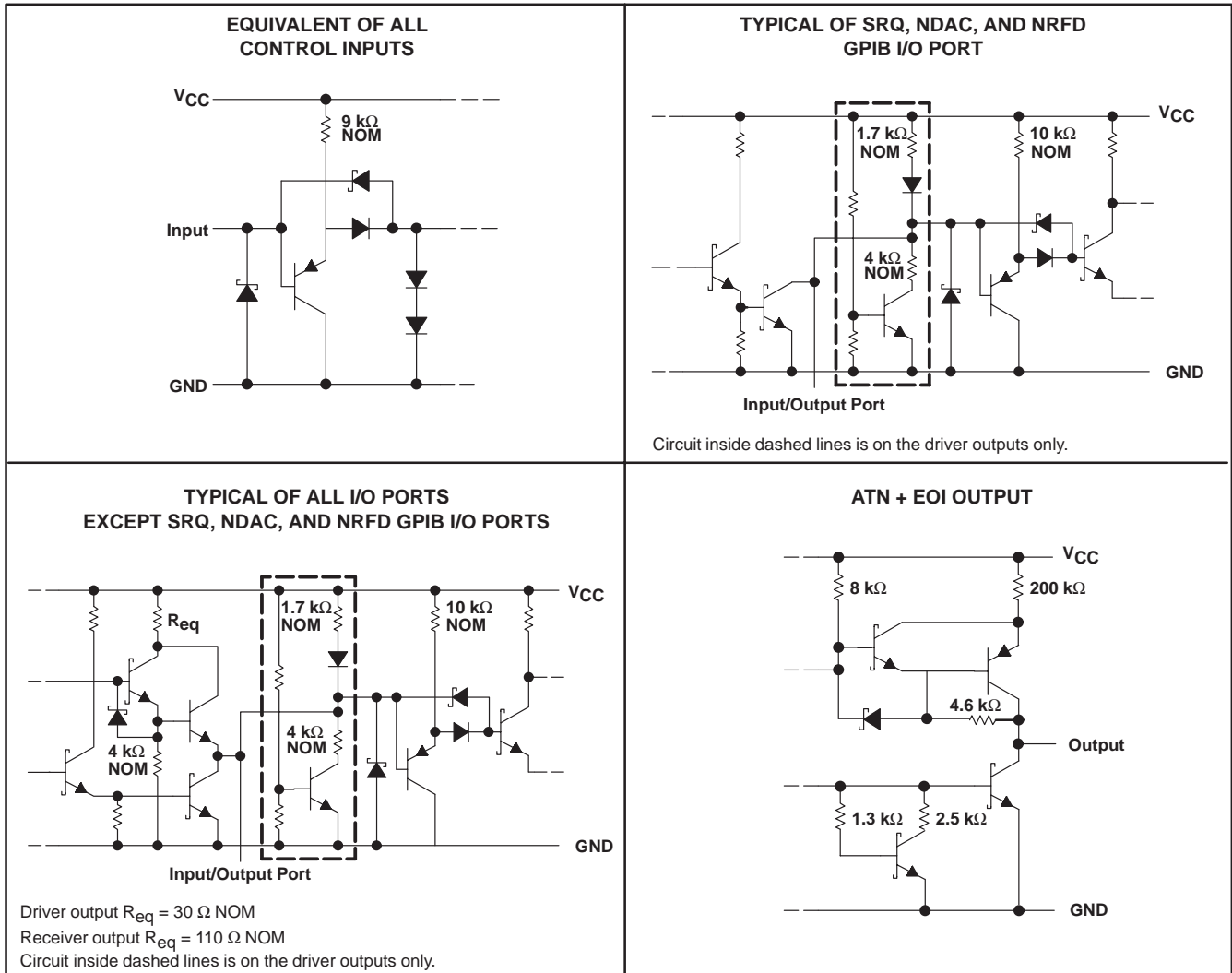

### absolute maximum ratings over operating free-air temperature range (unless otherwise noted)†

Supply voltage, $V_{CC}$ (see Note 1)	7 V
Input voltage	5.5 V
Low-level driver output current	100 mA
Package thermal impedance, $\theta_{JA}$ (see Note 2)	81°C/W
Storage temperature range, $T_{stg}$	-65°C to 150°C
Lead temperature 1,6 mm (1/16 inch) from the case for 10 seconds	260°C

† Stresses beyond those listed under “absolute maximum ratings” may cause permanent damage to the device. These are stress ratings only, and functional operation of the device at these or any other conditions beyond those indicated under “recommended operating conditions” is not implied. Exposure to absolute-maximum-rated conditions for extended periods may affect device reliability.

- NOTES: 1. All voltage values are with respect to network ground terminal.  
2. The package thermal impedance is calculated in accordance with JESD 51.

# SN75ALS164

## OCTAL GENERAL-PURPOSE INTERFACE BUS TRANSCEIVER

SLLS022C – JUNE 1986 – REVISED MAY 1998

### recommended operating conditions

		MIN	NOM	MAX	UNIT
Supply voltage, $V_{CC}$		4.75	5	5.25	V
High-level input voltage, $V_{IH}$		2			V
Low-level input voltage, $V_{IL}$		0.8			V
High-level output current, $I_{OH}$	Bus ports with 3-state outputs	– 5.2			mA
	Terminal ports	– 800			$\mu$ A
	ATN + EOI	– 400			
Low-level output current, $I_{OL}$	Bus ports	48			mA
	Terminal ports	16			
	ATN + EOI	4			
Operating free-air temperature, $T_A$		0	70		$^{\circ}$ C

### electrical characteristics over recommended supply-voltage and operating free-air temperature ranges (unless otherwise noted)

PARAMETER		TEST CONDITIONS		MIN	TYP†	MAX	UNIT
$V_{IK}$	Input clamp voltage	$I_I = -18$ mA		– 0.8	– 1.5		V
$V_{hys}$	Hysteresis ( $V_{T+} - V_{T-}$ )	Bus		0.4	0.65		V
$V_{OH}^{\ddagger}$	High-level output voltage	Terminal	$I_{OH} = -800$ $\mu$ A	2.7	3.5		V
		Bus	$I_{OH} = -5.2$ mA	2.5	3.3		
		ATN+EOI	$I_{OH} = -400$ $\mu$ A	2.7			
$V_{OL}$	Low-level output voltage	Terminal	$I_{OL} = 16$ mA		0.3	0.5	V
		Bus	$I_{OL} = 48$ mA		0.35	0.5	
		ATN+EOI	$I_{OL} = 4$ mA			0.4	
$I_I$	Input current at maximum input voltage	Terminal§	$V_I = 5.5$ V		0.2	100	$\mu$ A
		ATN, EOI	$V_I = 5.5$ V			200	
$I_{IH}$	High-level input current	Terminal control	$V_I = 2.7$ V		0.1	20	$\mu$ A
		ATN, EOI	$V_I = 2.7$ V			40	
$I_{IL}$	Low-level input current	Terminal control	$V_I = 0.5$ V		– 10	– 100	$\mu$ A
		ATN, EOI	$V_I = 0.5$ V			– 500	
$V_{I/O}(\text{bus})$	Voltage at bus port	Driver disabled	$I_{I(\text{bus})} = 0$	2.5	3.0	3.7	V
			$I_{I(\text{bus})} = -12$ mA			– 1.5	
$I_{I/O}(\text{bus})$	Current into bus port	Power on	Driver disabled	$V_{I(\text{bus})} = -1.5$ V to 0.4 V	– 1.3		mA
				$V_{I(\text{bus})} = 0.4$ V to 2.5 V	0	– 3.2	
				$V_{I(\text{bus})} = 2.5$ V to 3.7 V		+ 2.5	
				$V_{I(\text{bus})} = 3.7$ V to 5 V	0	2.5	
				$V_{I(\text{bus})} = 5$ V to 5.5 V	0.7	2.5	
		Power off	$V_{CC} = 0$ , $V_{I(\text{bus})} = 0$ to 2.5 V		– 40	$\mu$ A	
$I_{OS}$	Short-circuit output current	Terminal		– 15	– 35	– 75	mA
		Bus		– 25	– 50	– 125	
		ATN + EOI		– 10		– 100	
$I_{CC}$	Supply current	No load, TE, DC, and SC low		55	75		mA
$C_{I/O}(\text{bus})$	Bus-port capacitance	$V_{CC} = 0$ to 5 V, $V_{I/O} = 0$ to 2 V, $f = 1$ MHz		30			pF

† All typical values are at  $V_{CC} = 5$  V,  $T_A = 25^{\circ}$ C.

‡  $V_{OH}$  applies for 3-state outputs only.

§ Except ATN and EOI terminals.



# SN75ALS164

## OCTAL GENERAL-PURPOSE INTERFACE BUS TRANSCEIVER

SLLS022C – JUNE 1986 – REVISED MAY 1998

### switching characteristics over recommended operating free-air temperature range, $V_{CC} = 5\text{ V}$

PARAMETER		FROM (INPUT)	TO (OUTPUT)	TEST CONDITIONS	MIN	TYP	MAX	UNIT
$t_{PLH}$	Propagation delay time, low-to-high-level output	Terminal	Bus	$C_L = 30\text{ pF}$ , See Figure 1		10	20	ns
$t_{PHL}$	Propagation delay time, high-to-low-level output					12	20	
$t_{PLH}$	Propagation delay time, low-to-high-level output	Bus	Terminal	$C_L = 30\text{ pF}$ , See Figure 2		5	10	ns
$t_{PHL}$	Propagation delay time, high-to-low-level output					7	14	
$t_{PLH}$	Propagation delay time, low-to-high-level output	Terminal ATN or Terminal EOI	ATN+EOI	$C_L = 15\text{ pF}$ , See Figure 3		3.5	10	ns
$t_{PHL}$	Propagation delay time, high-to-low-level output	Terminal ATN or Terminal EOI	ATN+EOI	$C_L = 15\text{ pF}$ , See Figure 3		7	15	ns
$t_{PZH}$	Output enable time to high level	TE, DC, or SC	Bus (ATN, EOI, REN, IFC, and DAV)	$C_L = 15\text{ pF}$ , See Figure 4			30	ns
$t_{PHZ}$	Output disable time from high level						20	
$t_{PZL}$	Output enable time to low level						45	
$t_{PLZ}$	Output disable time from low level						20	
$t_{PZH}$	Output enable time to high level	TE, DC, or SC	Terminal	$C_L = 15\text{ pF}$ , See Figure 5			30	ns
$t_{PHZ}$	Output disable time from high level						25	
$t_{PZL}$	Output enable time to low level						30	
$t_{PLZ}$	Output disable time from low level						25	



**PARAMETER MEASUREMENT INFORMATION**

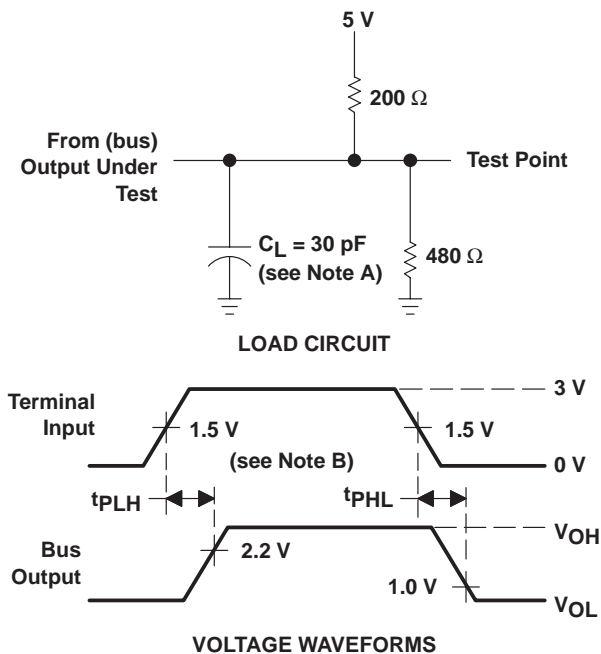

- NOTES: A.  $C_L$  includes probe and jig capacitance.  
 B. The input pulse is supplied by a generator having the following characteristics:  $PRR \leq 1$  MHz, 50% duty cycle,  $t_r \leq 6$  ns,  $t_f \leq 6$  ns,  $Z_O = 50 \Omega$ .

**Figure 1. Terminal-to-Bus Load Circuit and Voltage Waveforms**

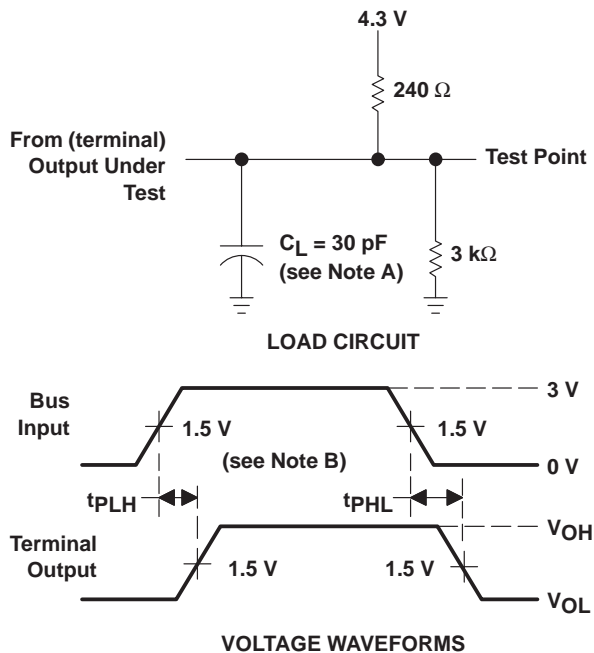

- NOTES: A.  $C_L$  includes probe and jig capacitance.  
 B. The input pulse is supplied by a generator having the following characteristics:  $PRR \leq 1$  MHz, 50% duty cycle,  $t_r \leq 6$  ns,  $t_f \leq 6$  ns,  $Z_O = 50 \Omega$ .

**Figure 2. Bus-to-Terminal Load Circuit and Voltage Waveforms**

# SN75ALS164 OCTAL GENERAL-PURPOSE INTERFACE BUS TRANSCEIVER

SLLS022C – JUNE 1986 – REVISED MAY 1998

## PARAMETER MEASUREMENT INFORMATION

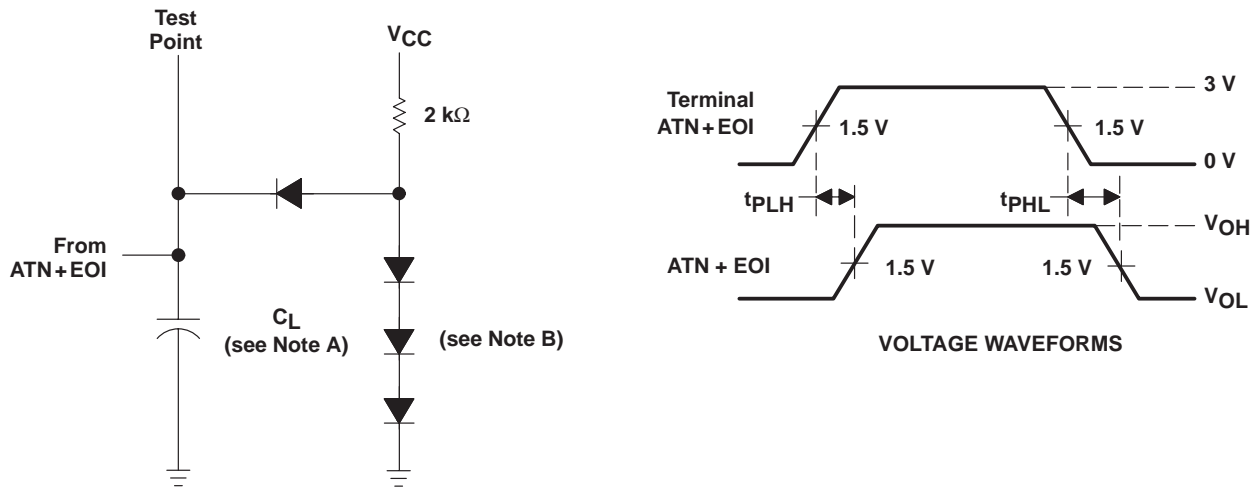

### LOAD CIRCUIT

- NOTES: A. C<sub>L</sub> includes probe and jig capacitance.  
B. All diodes are 1N916 or 1N3064

Figure 3. ATN + EOI Load Circuit and Voltage Waveforms



**PARAMETER MEASUREMENT INFORMATION**

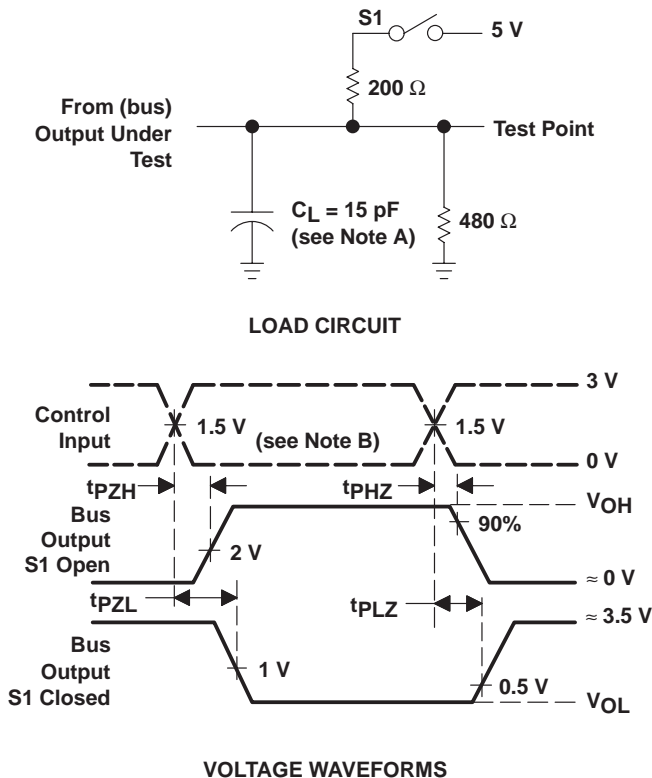

- NOTES: A.  $C_L$  includes probe and jig capacitance.  
 B. The input pulse is supplied by a generator having the following characteristics:  $PRR \leq 1 \text{ MHz}$ , 50% duty cycle,  $t_r \leq 6 \text{ ns}$ ,  $t_f \leq 6 \text{ ns}$ ,  $Z_O = 50 \Omega$ .

**Figure 4. Bus Load Circuit and Voltage Waveforms**

# SN75ALS164 OCTAL GENERAL-PURPOSE INTERFACE BUS TRANSCEIVER

SLLS022C – JUNE 1986 – REVISED MAY 1998

## PARAMETER MEASUREMENT INFORMATION

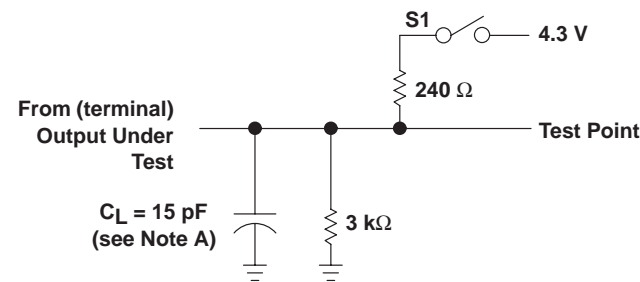

LOAD CIRCUIT

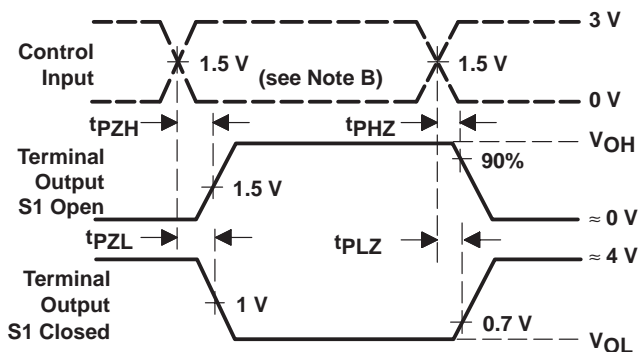

VOLTAGE WAVEFORMS

- NOTES: A.  $C_L$  includes probe and jig capacitance.  
 B. The input pulse is supplied by a generator having the following characteristics:  $PRR \leq 1 \text{ MHz}$ , 50% duty cycle,  $t_r \leq 6 \text{ ns}$ ,  $t_f \leq 6 \text{ ns}$ ,  $Z_O = 50 \Omega$ .

Figure 5. Terminal Load Circuit and Voltage Waveforms

TYPICAL CHARACTERISTICS

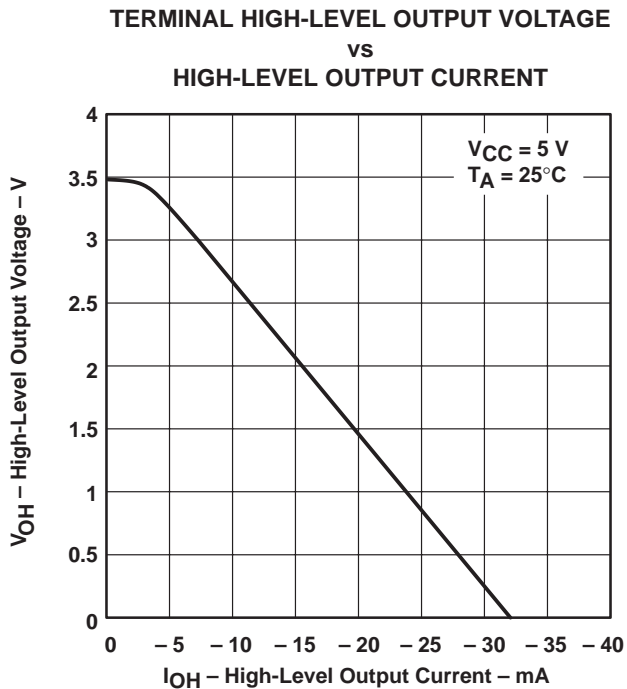

Figure 6

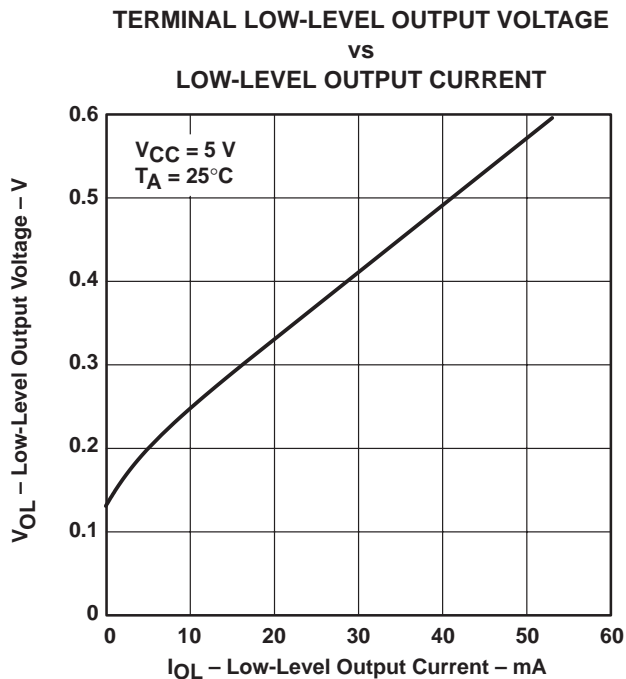

Figure 7

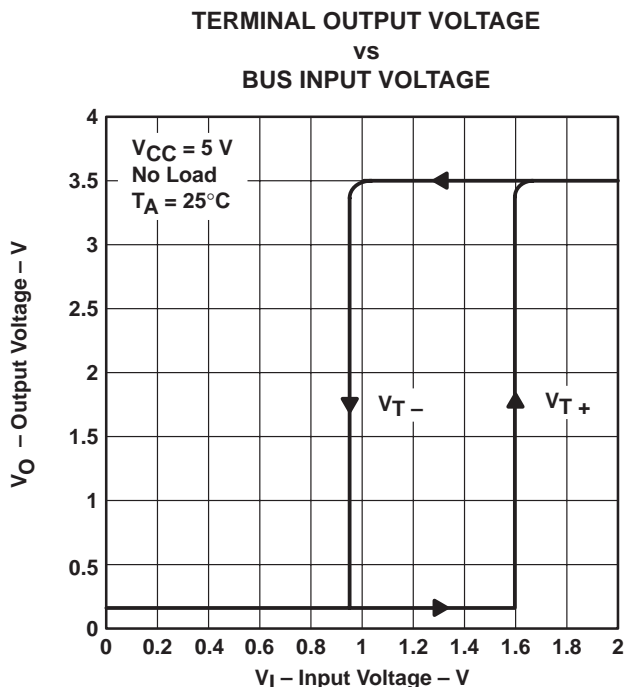
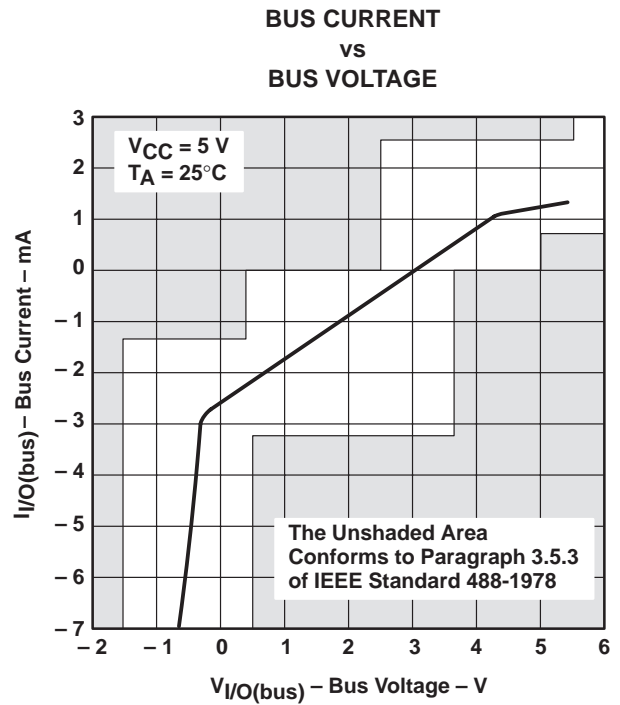
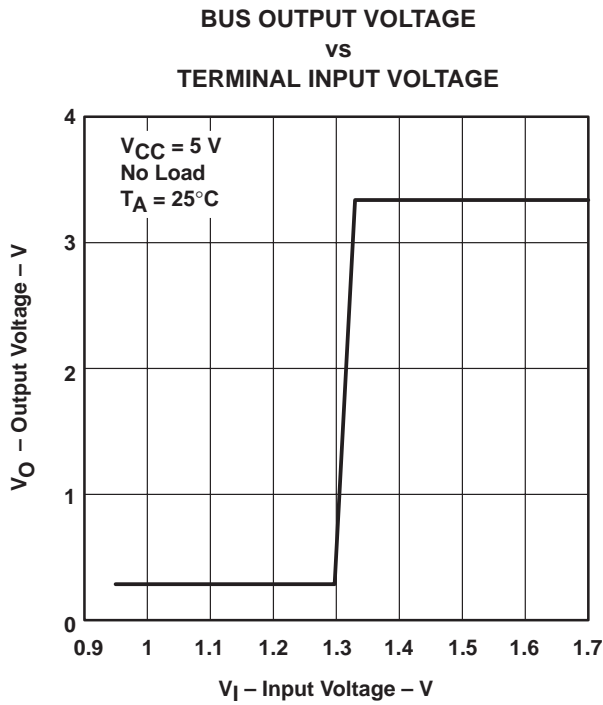
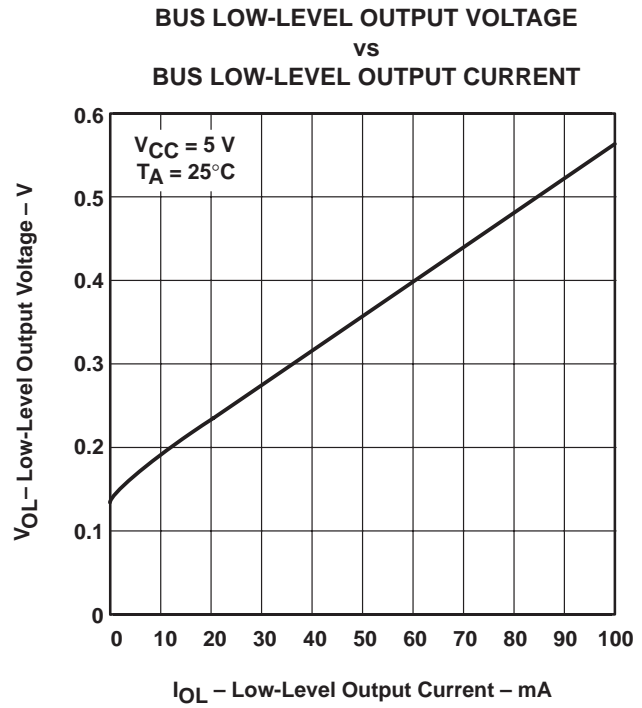
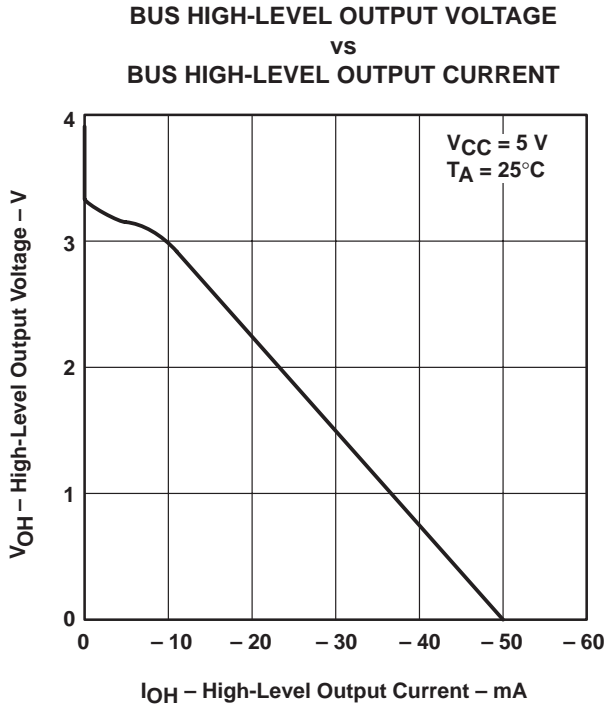

Figure 8

# SN75ALS164 OCTAL GENERAL-PURPOSE INTERFACE BUS TRANSCEIVER

SLLS022C – JUNE 1986 – REVISED MAY 1998

## TYPICAL CHARACTERISTICS



## IMPORTANT NOTICE

Texas Instruments and its subsidiaries (TI) reserve the right to make changes to their products or to discontinue any product or service without notice, and advise customers to obtain the latest version of relevant information to verify, before placing orders, that information being relied on is current and complete. All products are sold subject to the terms and conditions of sale supplied at the time of order acknowledgement, including those pertaining to warranty, patent infringement, and limitation of liability.

TI warrants performance of its semiconductor products to the specifications applicable at the time of sale in accordance with TI's standard warranty. Testing and other quality control techniques are utilized to the extent TI deems necessary to support this warranty. Specific testing of all parameters of each device is not necessarily performed, except those mandated by government requirements.

CERTAIN APPLICATIONS USING SEMICONDUCTOR PRODUCTS MAY INVOLVE POTENTIAL RISKS OF DEATH, PERSONAL INJURY, OR SEVERE PROPERTY OR ENVIRONMENTAL DAMAGE ("CRITICAL APPLICATIONS"). TI SEMICONDUCTOR PRODUCTS ARE NOT DESIGNED, AUTHORIZED, OR WARRANTED TO BE SUITABLE FOR USE IN LIFE-SUPPORT DEVICES OR SYSTEMS OR OTHER CRITICAL APPLICATIONS. INCLUSION OF TI PRODUCTS IN SUCH APPLICATIONS IS UNDERSTOOD TO BE FULLY AT THE CUSTOMER'S RISK.

In order to minimize risks associated with the customer's applications, adequate design and operating safeguards must be provided by the customer to minimize inherent or procedural hazards.

TI assumes no liability for applications assistance or customer product design. TI does not warrant or represent that any license, either express or implied, is granted under any patent right, copyright, mask work right, or other intellectual property right of TI covering or relating to any combination, machine, or process in which such semiconductor products or services might be or are used. TI's publication of information regarding any third party's products or services does not constitute TI's approval, warranty or endorsement thereof.