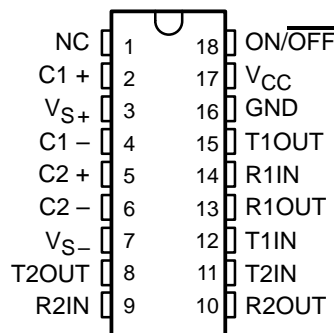


**LT1080, LT1081**  
**ADVANCED LOW-POWER**  
**5-V DUAL EIA-232 DRIVER/RECEIVERS**  
 SLLS050A – D3121, SEPTEMBER 1989 – REVISED FEBRUARY 1991

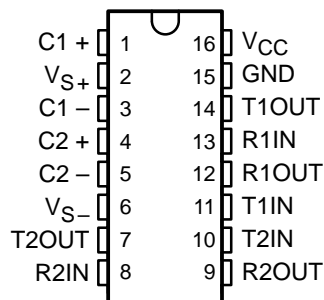
- Operates With Single 5-V Power Supply
- Generates  $\pm 9$ -V Supply Voltages With Only 1- $\mu$ F Capacitors
- Designed to Avoid Latch-Up
- CMOS Comparable Low Power . . . 60 mW
- Features Superior to CMOS:
  - Improved Speed . . . Operates Over 64K Baud
  - Improved Protection . . . Outputs Can Be Forced to  $\pm 30$  V Without Damage
  - 3-State Outputs Are at High Impedance When Off
- Power Additional EIA-232 Drivers . . . 10 mA
- 1- $\mu$ A Supply Current in Shutdown
- Available With or Without Shutdown
- Suitable for ANSI/EIA-232-D-1986 Applications (Revision of EIA Std RS-232-C)
- Designed to Be Interchangeable With Linear Technology LT1080 and LT1081

LT1080C, LT1080I . . . DW OR N PACKAGE  
(TOP VIEW)



NC – No internal connection

LT1081C, LT1081I . . . DW OR N PACKAGE  
(TOP VIEW)



**description**

The LT1080 and LT1081 are dual driver/receivers that include a charge pump to supply EIA-232 voltage levels from a single 5-V supply. These interface-optimized devices are designed to avoid latch-up and provide a realistic balance between CMOS levels of power dissipation and real-world requirements for ruggedness. The driver outputs are fully protected against overload and can be shorted to  $\pm 30$  V. Unlike CMOS devices, the advanced architecture of the LT1080 and LT1081 does not load the signal line when shut down or when the power is off. Both the receiver and EIA-232 outputs are put into a high-impedance state. An advanced output stage allows driving higher capacitive loads at higher speeds with exceptional resistance to ESD.

Applications for these devices include portable computers, battery-powered EIA-232 systems, power-supply generators, terminals, and modems.

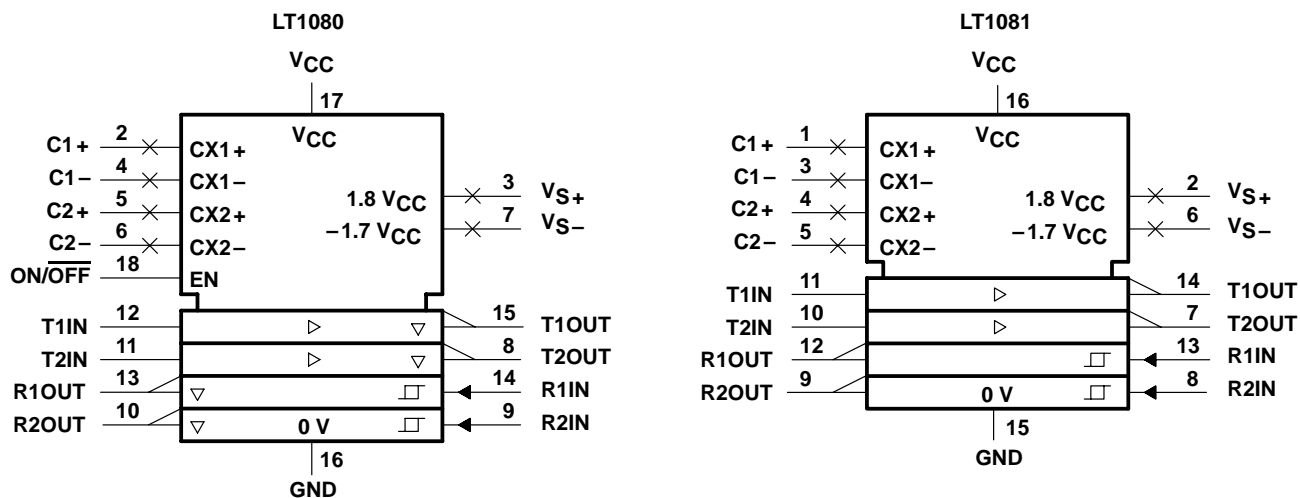
The LT1080C and LT1081C are characterized for operation from 0°C to 70°C. The LT1080I and LT1081I are characterized for operation from -40°C to 85°C.

PRODUCTION DATA information is current as of publication date. Products conform to specifications per the terms of Texas Instruments standard warranty. Production processing does not necessarily include testing of all parameters.



**LT1080, LT1081**  
**ADVANCED LOW-POWER**  
**5-V DUAL EIA-232 DRIVER/RECEIVERS**  
 SLLS050A – D3121, SEPTEMBER 1989 – REVISED FEBRUARY 1991

**logic symbols†**



† These symbols are in accordance with ANSI/IEEE Std 91-1984 and IEC Publication 617-12.

**Terminal Functions**

PIN NAME	NO.†	I/O	DESCRIPTION
C1 +	2 [1]		External capacitor C1
C1 -	4 [3]		
C2 +	5 [4]		External capacitor C2
C2 -	6 [5]		
GND	16 [15]		Ground pin
ON/OFF	18	I	Controls the operation mode and is TTL/CMOS compatible. A low logic level places the device in the shutdown mode, which reduces input supply current to near zero and places both driver and receiver outputs in a high-impedance state. This input is not available on the LT1081.
R1IN	14 [13]	I	Receiver input. Accepts EIA-232 voltage levels ( $\pm 30$ V) and has hysteresis to provide noise immunity.
R2IN	9 [8]	I	Same as R1IN
R1OUT	13 [12]	O	Receiver output with TTL/CMOS voltage levels. Output is in a high-impedance state when in the shutdown mode or when $V_{CC} = 0$ to allow bus operation. Fully short-circuit protected to GND or $V_{CC}$ with power on, power off, or in the shutdown mode.
R2OUT	10 [9]	O	Same as R1OUT
T1IN	12 [11]	I	EIA-232 driver input pin. Input is TTL/CMOS compatible. Unused inputs should be tied to $V_{CC}$ .
T2IN	11 [10]	I	Same as T1IN
T1OUT	15 [14]	O	Driver output with EIA-232 voltage levels. Outputs are in a high-impedance state when in the shutdown mode or when $V_{CC} = 0$ to allow bus operation. Fully short-circuit protected to GND or $V_{CC}$ with power on, power off, or in the shutdown mode.
T2OUT	8 [7]	O	Same as T1OUT
$V_{S+}$	3 [2]		Positive supply for EIA-232 drivers. Requires an external capacitor (1- $\mu$ F) for charge storage.
$V_{S-}$	7 [6]		Negative supply for EIA-232 drivers. Requires an external capacitor (1- $\mu$ F) for charge storage.
$V_{CC}$	17 [16]		Input supply pin. Supply current drops to near zero in the shutdown mode. Driver and receiver outputs are in a high-impedance state when $V_{CC} = 0$ .

† Pin numbers in brackets are for the LT1081.



**absolute maximum ratings over operating free-air temperature range (unless otherwise noted)**

Supply voltage, $V_{CC}$ (see Note 1)	6 V
Positive output supply voltage	12 V
Negative output supply voltage	–12 V
Input voltage range: Driver	$\pm 12$ V
Receiver	$\pm 30$ V
ON/OFF	GND to 12 V
Output voltage range: T1OUT, T2OUT	$V_{S-} + 30$ V to $V_{S+} - 30$ V
R1OUT, R2OUT	–0.3 V to $V_{CC} + 0.3$ V
Duration of output short circuit at (or below) 25°C: $V_{S+}$	30 s
$V_{S-}$	30 s
Driver or receiver output	unlimited
Continuous total dissipation	See Dissipation Rating Table
Operating free-air temperature range: LT1080C, LT1081C	0°C to 70°C
LT1080I, LT1081I	–40°C to 85°C
Storage temperature range	–65°C to 150°C
Lead temperature 1,6 mm (1/16 inch) from case for 10 seconds	260°C

NOTE 1: All voltage values are with respect to network ground terminal.

**DISSIPATION RATING TABLE**

PACKAGE	$T_A \leq 25^\circ\text{C}$ POWER RATING	DERATING FACTOR ABOVE $T_A = 25^\circ\text{C}$	$T_A = 70^\circ\text{C}$ POWER RATING	$T_A = 85^\circ\text{C}$ POWER RATING
DW	1025 mW	8.2 mW/°C	656 mW	533 mW
N	1150 mW	9.2 mW/°C	736 mW	598 mW

**recommended operating conditions**

	LT1080C, LT1081C			LT1080I, LT1081I			UNIT
	MIN	TYP	MAX	MIN	TYP	MAX	
Supply voltage, $V_{CC}$	4.5	5	5.5	4.5	5	5.5	V
High-level input voltage, $V_{IH}$ (T1IN, T2IN)	2		5.5	2		5.5	V
Low-level input voltage, $V_{IL}$ (T1IN, T2IN)			0.8			0.8	V
Operating free-air temperature, $T_A$	0		70	–40		85	°C

**LT1080, LT1081**  
**ADVANCED LOW-POWER**  
**5-V DUAL EIA-232 DRIVER/RECEIVERS**  
 SLLS050A – D3121, SEPTEMBER 1989 – REVISED FEBRUARY 1991

electrical characteristics over recommended ranges of supply voltage and operating free-air temperature,  $V_I = 3\text{ V}$  (unless otherwise noted)

**driver section**

PARAMETER	TEST CONDITIONS	MIN	TYP†	MAX	UNIT
$V_{OM+}$ Positive-peak output voltage	$R_L = 3\text{ k}\Omega$ to GND	5	7.5		V
$V_{OM-}$ Negative-peak output voltage	$R_L = 3\text{ k}\Omega$ to GND	-5	-6.5		V
$I_{IH}$ High-level input current	$V_I = 2\text{ V}$ to $5.5\text{ V}$		5	20	$\mu\text{A}$
$I_{IL}$ Low-level input current	$V_I \leq 0.8\text{ V}$		-5	-20	$\mu\text{A}$
$I_{OHS}$ Output short-circuit current (sourcing)	$V_I = 0$ , $V_O = 0$ , $T_A = 25^\circ\text{C}$	-7	12		mA
$I_{OLS}$ Output short-circuit current (sinking)	$V_I = 2\text{ V}$ , $V_O = 0$ , $T_A = 25^\circ\text{C}$	7	-12		mA
$I_{OZ}$ High-impedance output current	Shutdown mode, $V_O = \pm 30\text{ V}$			100	$\mu\text{A}$

**receiver section**

PARAMETER	TEST CONDITIONS	MIN	TYP†	MAX	UNIT
$V_{T+}$ Positive-going input threshold voltage	LT1080C, LT1081C		1.7	2.4	V
	LT1080I, LT1081I		1.7	3	
$V_{T-}$ Negative-going input threshold voltage	LT1080C, LT1081C	0.8	1.3		V
	LT1080I, LT1081I	0.2	1.3		
$V_{hys}$ Input hysteresis		0.1	0.4	1	V
$r_i$ Input resistance	$T_A = 25^\circ\text{C}$	3	5	7	k $\Omega$
$V_{OH}$ High-level output voltage	$I_{OH} = -160\text{ }\mu\text{A}$ , $V_{CC} = 5\text{ V}$	3.5	4.8		V
$V_{OL}$ Low-level output voltage	$I_{OL} = 1.6\text{ mA}$		0.2	0.4	V
$I_{OSH}$ Output short-circuit current (sourcing)	$V_I = 3\text{ V}$ , $V_O = 0$ , $T_A = 25^\circ\text{C}$	-0.6	-1		mA
$I_{OSL}$ Output short-circuit current (sinking)	$V_I = 3\text{ V}$ , $V_O = V_{CC}$ , $T_A = 25^\circ\text{C}$	10	20		mA
$I_{OZ}$ High-impedance output current	Shutdown mode, $V_O = 0$ to $V_{CC}$			10	$\mu\text{A}$

**power supply section,  $V_{CC} = 5\text{ V}$ , driver outputs low (unless otherwise noted)**

PARAMETER	TEST CONDITIONS	MIN	TYP†	MAX	UNIT
$V_{S+}$ Supply output voltage	$I_S = 0$ , $T_A = 25^\circ\text{C}$	8	9		V
	$I_S = 10\text{ mA}$ , $T_A = 25^\circ\text{C}$	7	8		
	$I_S = 15\text{ mA}$ , $T_A = 25^\circ\text{C}$	6.5	7.5		
$V_{S-}$ Supply output voltage	$I_S = 0$ , $T_A = 25^\circ\text{C}$	-7.5	-8.5		V
	$I_S = 10\text{ mA}$ , $T_A = 25^\circ\text{C}$	-5.5	-6.5		
	$I_S = 15\text{ mA}$ , $T_A = 25^\circ\text{C}$	-5	-6		
$I_{CC}$ Supply current			10	22	mA
$I_{CC(off)}$ Off-state supply current (LT1080)	ON/OFF at $0.4\text{ V}$			100	$\mu\text{A}$
$I_I$ Input current (ON/OFF) (LT1080)	$V_I = 5\text{ V}$			80	$\mu\text{A}$
	$V_I = 0\text{ V}$			-15	

† All typical values are at  $V_{CC} = 5\text{ V}$ ,  $T_A = 25^\circ\text{C}$ .

**operating characteristics over recommended range of supply voltage,  $V_I = 3\text{ V}$ ,  $T_A = 25^\circ\text{C}$**

PARAMETER	TEST CONDITIONS	MIN	TYP	MAX	UNIT
SR Driver slew rate	$R_L = 3\text{ k}\Omega$ to $7\text{ k}\Omega$ , $C_L = 560\text{ pF}$ , See Note 2	4	15	30	V/ $\mu\text{s}$
$t_r(\text{supply})$ Supply rise time (see Note 3)	$C1 - C4 = 1\text{ }\mu\text{F}$		1		ms

- NOTES: 2. Meets EIA-232-D specifications for capacitive loads greater than  $560\text{ pF}$ .  
 3. Time from either shutdown input ON/OFF (LT1080) goes active high or  $V_{CC}$  power on (LT1081) until the output voltages reach  $V_{S+} \geq 6\text{ V}$  and  $V_{S-} \leq -6\text{ V}$ .



TYPICAL CHARACTERISTICS†

HIGH- AND LOW-LEVEL  
 DRIVER OUTPUT VOLTAGE  
 vs  
 FREE-AIR TEMPERATURE

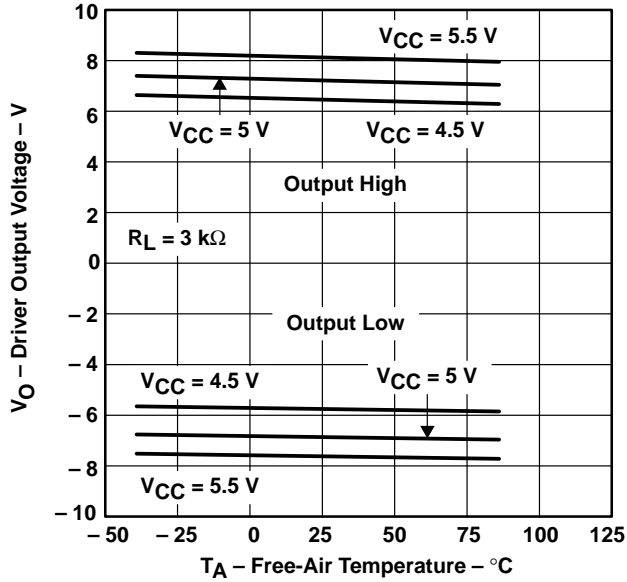


Figure 1

HIGH-IMPEDANCE  
 DRIVER OUTPUT CURRENT  
 vs  
 FREE-AIR TEMPERATURE

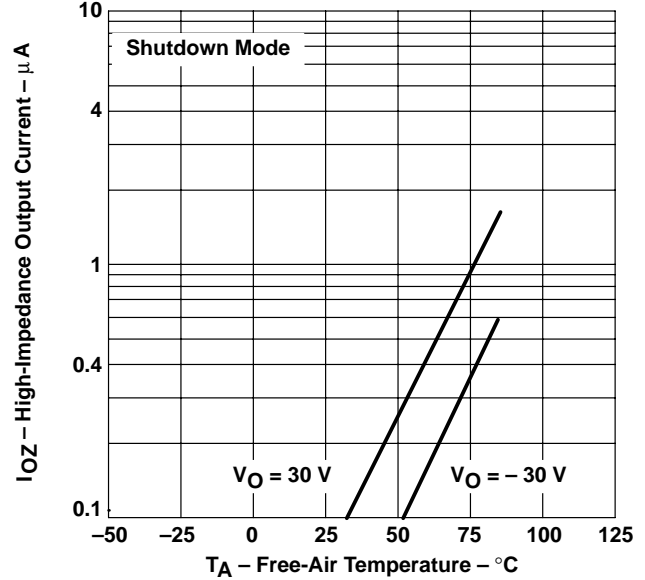


Figure 2

POSITIVE-GOING AND NEGATIVE-GOING  
 RECEIVER INPUT THRESHOLD VOLTAGE  
 vs  
 FREE-AIR TEMPERATURE

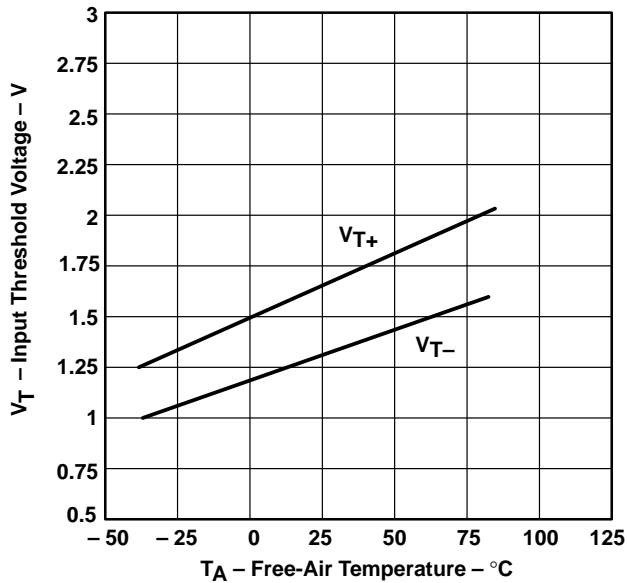


Figure 3

RECEIVER SOURCE CURRENT  
 AND SINK CURRENT  
 vs  
 FREE-AIR TEMPERATURE

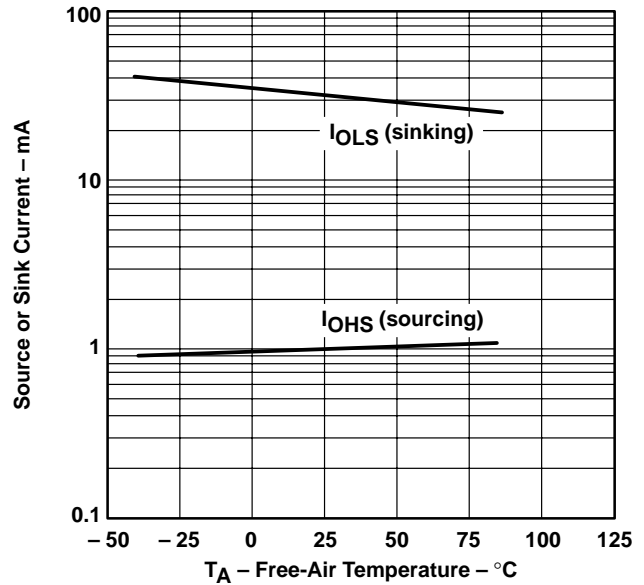
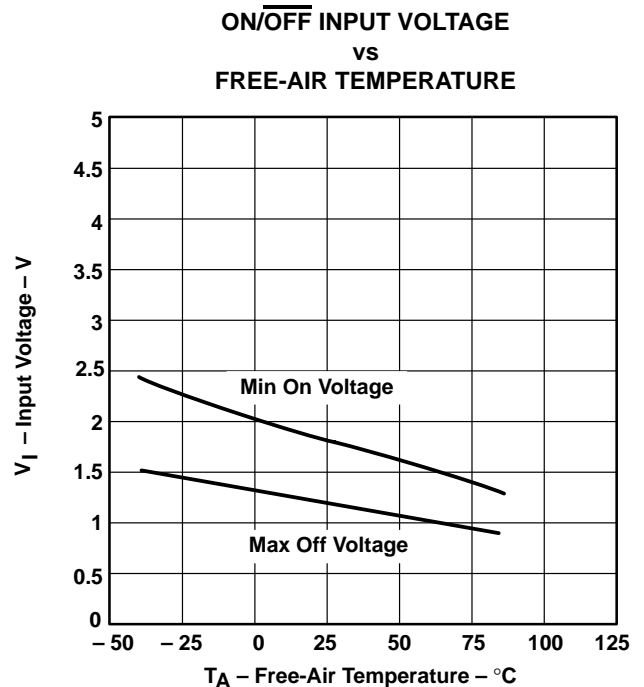
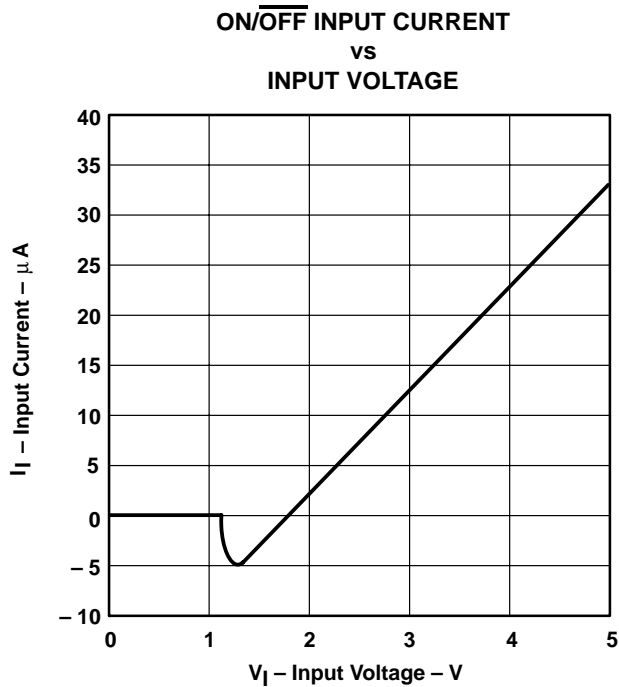
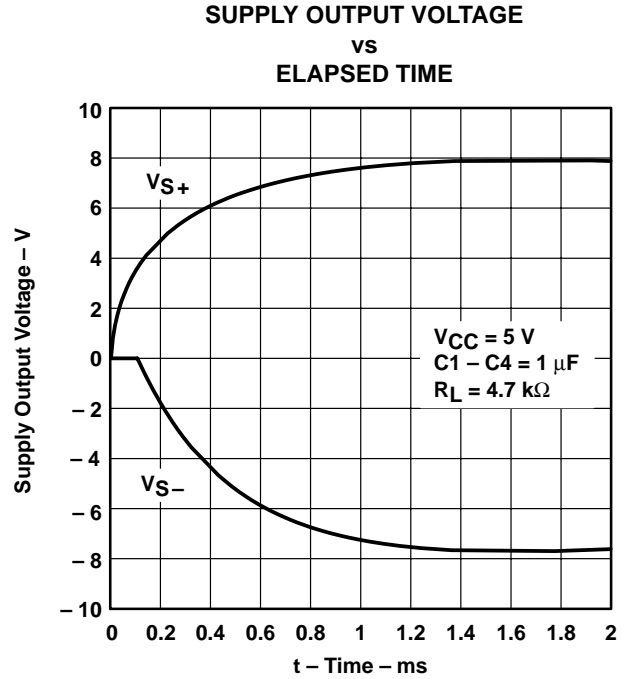
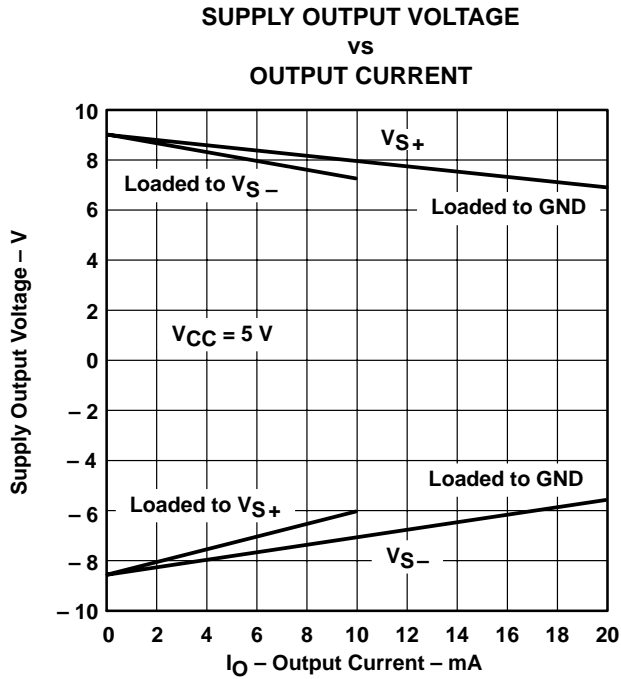


Figure 4

† Data at high and low temperatures are applicable only within the rated operating free-air temperature ranges of the various devices.

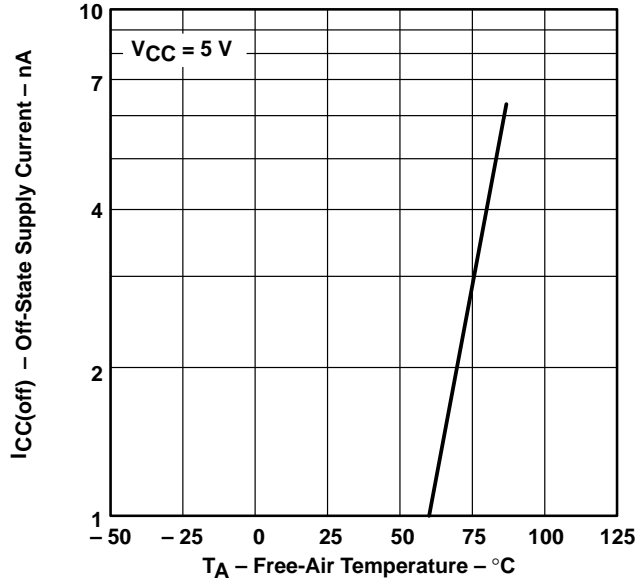
**TYPICAL CHARACTERISTICS†**



† Data at high and low temperatures are applicable only within the rated operating free-air temperature ranges of the various devices.

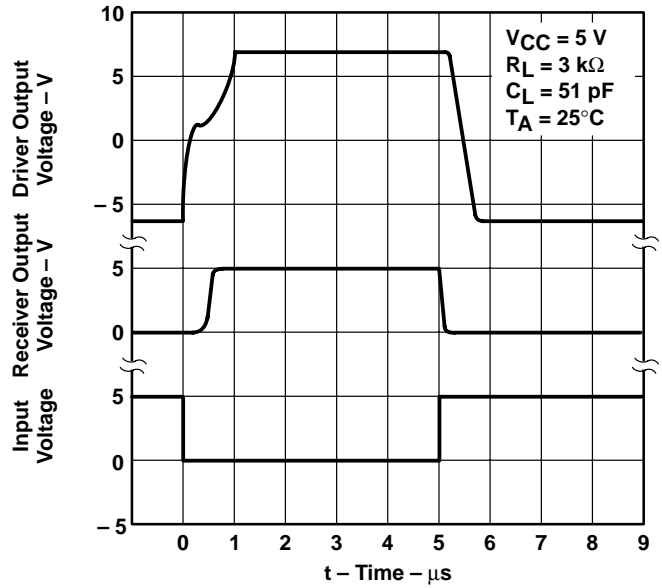
**TYPICAL CHARACTERISTICS†**

**OFF-STATE SUPPLY CURRENT**  
**vs**  
**FREE-AIR TEMPERATURE**



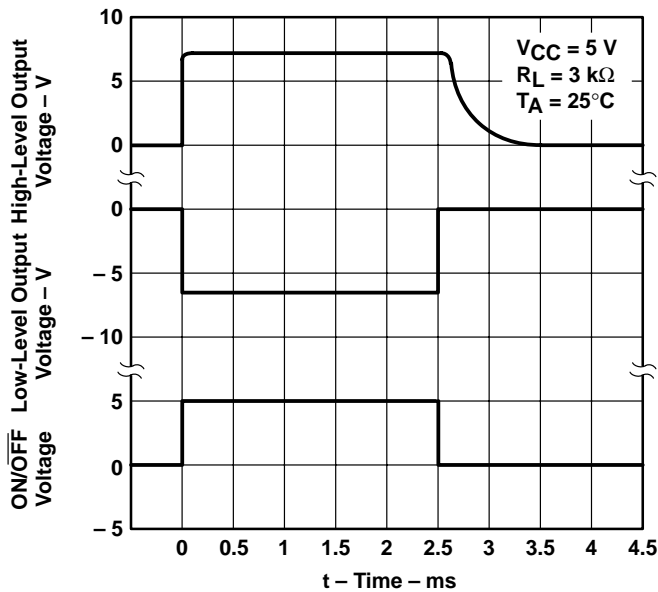
**Figure 9**

**DRIVER and RECEIVER**  
**PULSE RESPONSE**



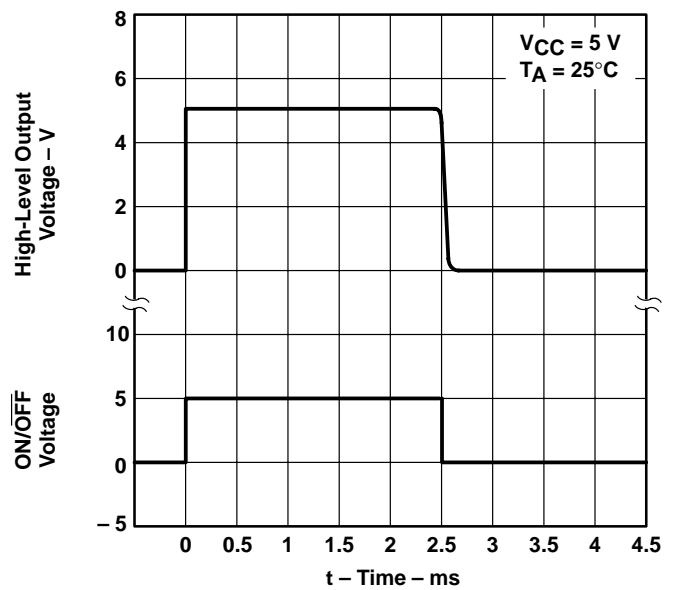
**Figure 10**

**ON/OFF TO DRIVER OUTPUT**  
**PULSE RESPONSE**



**Figure 11**

**ON/OFF TO RECEIVER**  
**PULSE RESPONSE**

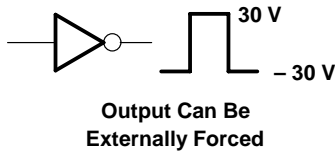


**Figure 12**

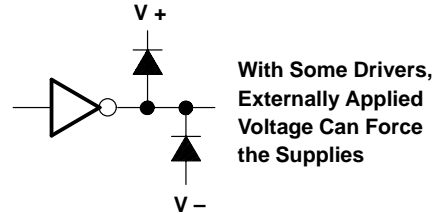
† Data at high and low temperatures are applicable only within the rated operating free-air temperature ranges of the various devices.

**APPLICATION INFORMATION**

The driver output stage of the LT1080 offers significantly improved protection over older bipolar and CMOS designs (see Figures 13 and 14). In addition to limiting current, the driver output can be externally forced to  $\pm 30$  V without damage, excessive current flow, or supply disruption. Some drivers have diodes connected between the outputs and the supplies, allowing externally applied voltages to cause excessive supply voltage to develop.

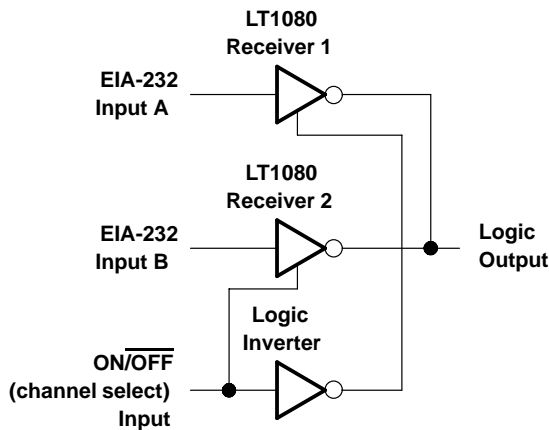


**Figure 13. LT1080/LT1081 Driver**

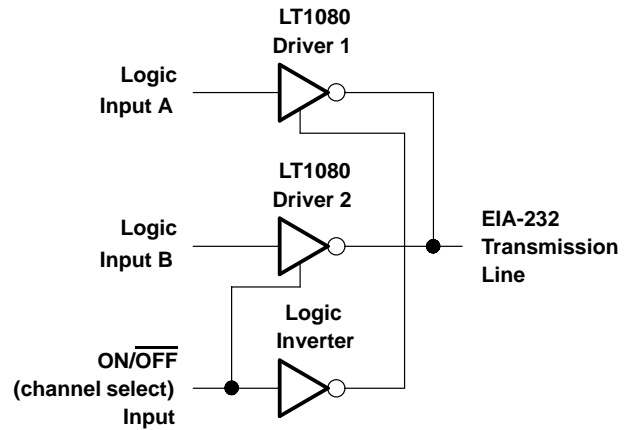


**Figure 14. Older EIA-232 Drivers and CMOS Drivers**

Placing the LT1080 in the shutdown mode (pin 18 low) puts both the driver and receiver outputs in a high-impedance state. This allows for bus operation and transceiver applications (see Figures 15–17). The shutdown mode also drops input supply current ( $V_{CC}$ ) to near zero for power-conscious systems.



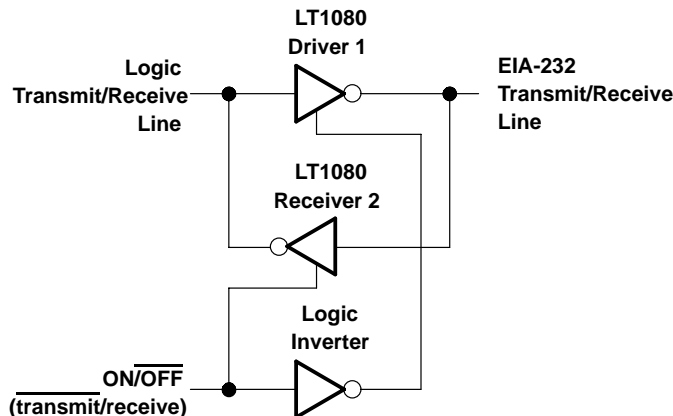
**Figure 15. Sharing a Receiver Line**



**Figure 16. Sharing a Transmitter Line**



**APPLICATION INFORMATION**

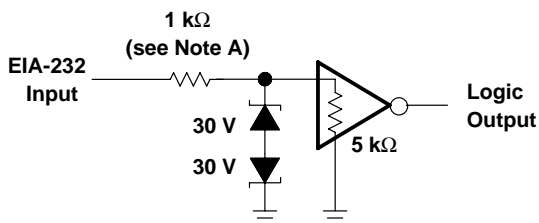


**Figure 17. Transceiver**

To protect against receiver input overloads in excess of  $\pm 30$  V, a voltage clamp can be placed on the data line and still maintain EIA-232 compatibility (see Figure 18).

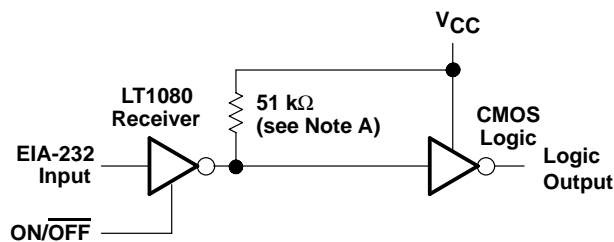
When driving CMOS logic from a receiver that will be used in the shutdown mode and when there is no other active receiver on the line, a 51-k $\Omega$  resistor can be placed from the logic input to  $V_{CC}$  to force a definite logic level when the receiver output is in a high-impedance state (see Figure 19).

The generated driver supplies ( $V_{S+}$  and  $V_{S-}$ ) may be used to power external circuitry such as other EIA-232 drivers or operational amplifiers (see Figure 20). They should be loaded with care, since excessive loading can cause the generated supply voltages to drop, causing the EIA-232 driver output voltages to fall below EIA-232 requirements. See Figure 5 for a comparison of generated supply voltage versus supply current.



NOTE A: A PTC thermistor will allow continuous overload of greater than  $\pm 100$  V.

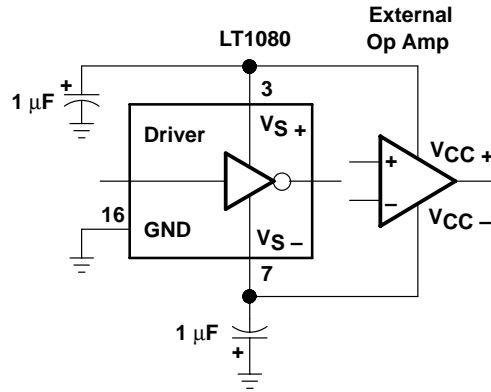
**Figure 18. Input Overload Protection**



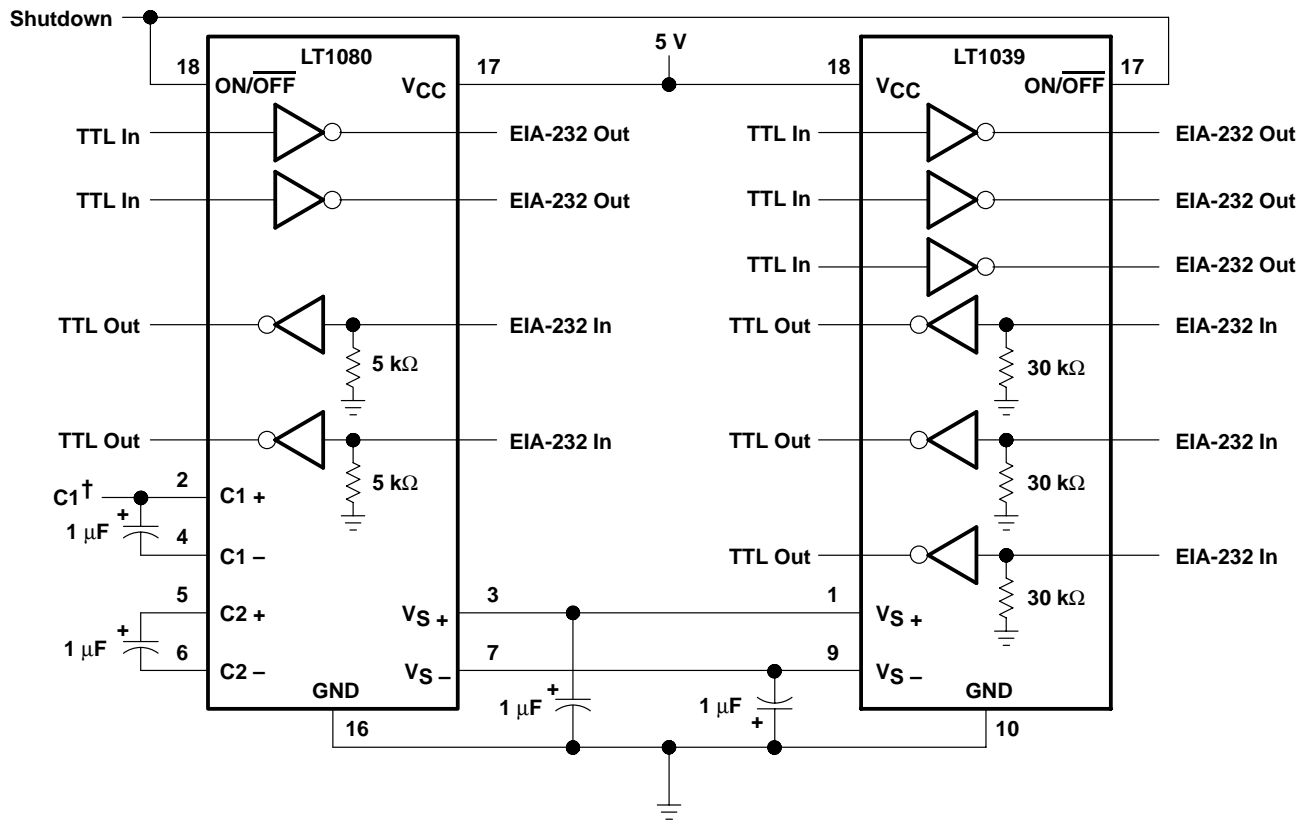
NOTE A: Forces logic input state when  $V_I$  is low.

**Figure 19. Forcing a Definite Logic Level**

**APPLICATION INFORMATION**



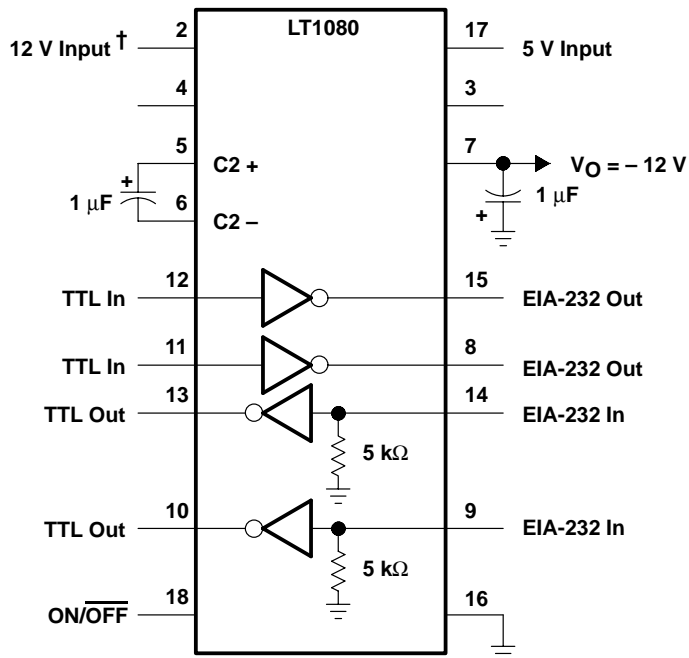
**Figure 20. Powering External Circuitry**



† In applications in which a separate second positive supply is available (such as 5 V and 12 V), the 12-V supply may be connected to pin 2 and C1 deleted. The power circuitry will then invert the 12-V supply. The 5-V supply is still needed to power the biasing circuitry and receivers.

**Figure 21. Supporting an LT1039 (Triple Driver/Receiver)**

**APPLICATION INFORMATION**



† C1+ used on LT1081

**Figure 22. Operating With 5 V and 12 V**



## **IMPORTANT NOTICE**

Texas Instruments (TI) reserves the right to make changes to its products or to discontinue any semiconductor product or service without notice, and advises its customers to obtain the latest version of relevant information to verify, before placing orders, that the information being relied on is current.

TI warrants performance of its semiconductor products and related software to the specifications applicable at the time of sale in accordance with TI's standard warranty. Testing and other quality control techniques are utilized to the extent TI deems necessary to support this warranty. Specific testing of all parameters of each device is not necessarily performed, except those mandated by government requirements.

Certain applications using semiconductor products may involve potential risks of death, personal injury, or severe property or environmental damage ("Critical Applications").

**TI SEMICONDUCTOR PRODUCTS ARE NOT DESIGNED, INTENDED, AUTHORIZED, OR WARRANTED TO BE SUITABLE FOR USE IN LIFE-SUPPORT APPLICATIONS, DEVICES OR SYSTEMS OR OTHER CRITICAL APPLICATIONS.**

Inclusion of TI products in such applications is understood to be fully at the risk of the customer. Use of TI products in such applications requires the written approval of an appropriate TI officer. Questions concerning potential risk applications should be directed to TI through a local SC sales office.

In order to minimize risks associated with the customer's applications, adequate design and operating safeguards should be provided by the customer to minimize inherent or procedural hazards.

TI assumes no liability for applications assistance, customer product design, software performance, or infringement of patents or services described herein. Nor does TI warrant or represent that any license, either express or implied, is granted under any patent right, copyright, mask work right, or other intellectual property right of TI covering or relating to any combination, machine, or process in which such semiconductor products or services might be or are used.