

# SN75126 QUADRUPLE LINE DRIVER

SLLS060B – FEBRUARY 1990 – REVISED MAY 1995

- Meets or Exceeds the Requirements of IBM™ System 360/370 Input/Output Interface Specification GA22-6974-3
- Minimum Output Voltage of 3.11 V at  $I_{OH} = -59.3$  mA
- Fault-Flag Circuit Output Signals Driver Output Fault
- Fault-Detection Current-Limit Circuit Minimizes Power Dissipation During a Fault Condition
- Dual Common Enable
- Individual Fault Flags
- Designed to Replace the MC3481

## description

The SN75126 quadruple line driver is designed to meet the IBM 360/370 I/O specification A22-6974-3. The output voltage is 3.11 V minimum (at  $I_{OH} = -59.3$  mA) over the recommended ranges of supply voltage (4.5 V to 5.95 V) and temperature. Driver outputs use a fault-detection current-limit circuit to allow high drive current but still minimize power dissipation when the output is shorted to ground. The SN75126 is compatible with standard TTL logic and supply voltages.

Fault-flag circuitry is designed to sense and signal a line short on any Y line. Upon detecting an output fault condition, the fault-flag circuit forces the driver output into a low state and signals a fault condition by causing the fault-flag output to go low.

The SN75126 can drive a 50-Ω load or a 90-Ω load as used in many I/O systems. Optimum performance can be achieved when the device is used with either the SN75128 or SN75129 line receivers. Also, see the SN751730 for new 360/370 interface designs.

The SN75126 is characterized for operation from 0°C to 70°C.

D OR N PACKAGE  
(TOP VIEW)

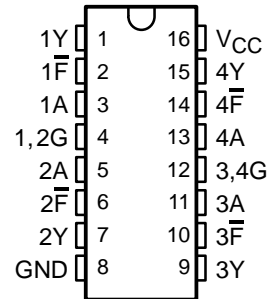

FUNCTION TABLE

INPUTS		OUTPUTS	
G	A	Y	F
L	X	L	H
H	H	H	H
H	H	S	L

H = high level,  
L = low level,  
X = irrelevant,  
S = shorted to ground

IBM is a trademark of International Business Machines Corp.

PRODUCTION DATA information is current as of publication date. Products conform to specifications per the terms of Texas Instruments standard warranty. Production processing does not necessarily include testing of all parameters.

 **TEXAS  
INSTRUMENTS**

POST OFFICE BOX 655303 • DALLAS, TEXAS 75265

Copyright © 1995, Texas Instruments Incorporated

# SN75126 QUADRUPLE LINE DRIVER

SLLS060B – FEBRUARY 1990 – REVISED MAY 1995

## logic symbol†

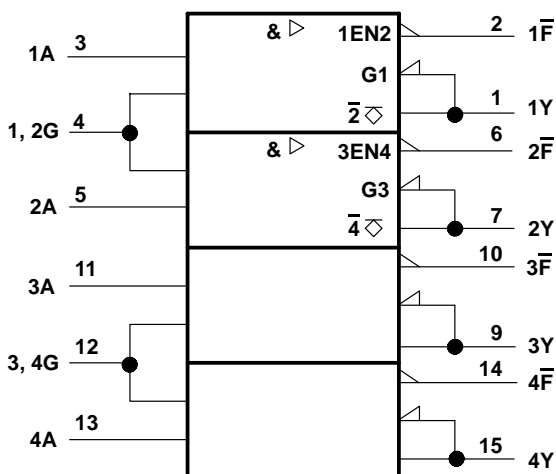

† This symbol is in accordance with ANSI/IEEE Std 91-1984 and IEC Publication 617-12.

## logic diagram (positive logic)

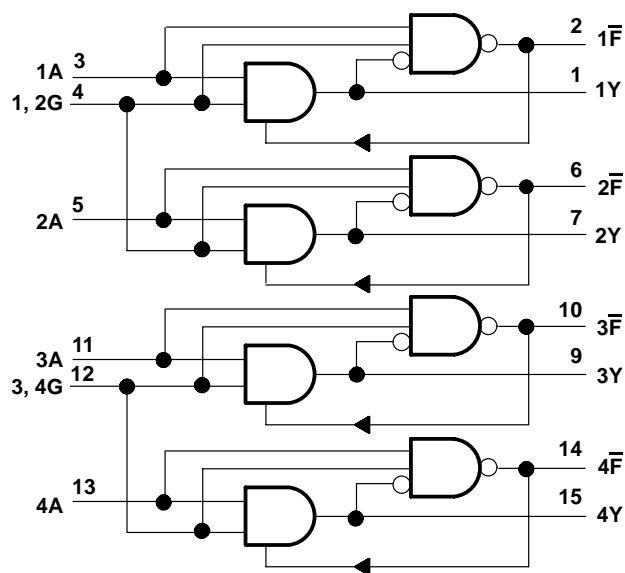

## schematics of inputs and outputs

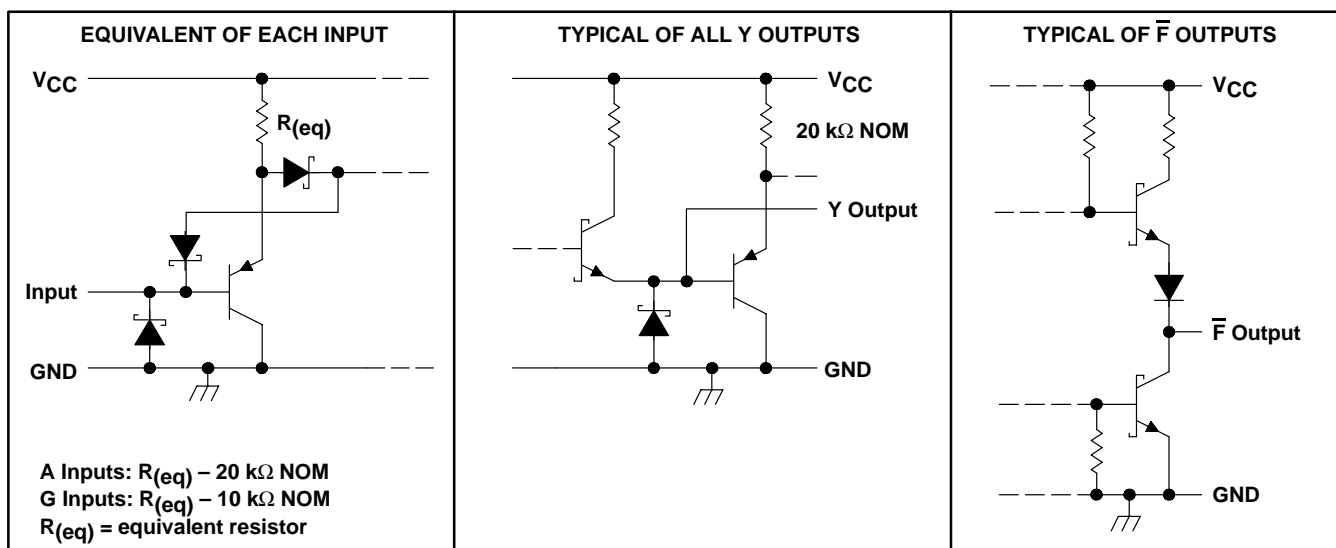

## absolute maximum ratings over operating free-air temperature range (unless otherwise noted)†

Supply voltage, $V_{CC}$	7 V
Input voltage, $V_I$	7 V
Continuous total power dissipation	See Dissipation Rating Table
Operating free-air temperature range, $T_A$	0°C to 70°C
Storage temperature range, $T_{Stg}$	-65°C to 150°C
Lead temperature 1,6 mm (1/16 inch) from case for 10 seconds	260°C

† Stresses beyond those listed under "absolute maximum ratings" may cause permanent damage to the device. These are stress ratings only, and functional operation of the device at these or any other conditions beyond those indicated under "recommended operating conditions" is not implied. Exposure to absolute-maximum-rated conditions for extended periods may affect device reliability.

**DISSIPATION RATING TABLE**

PACKAGE	$T_A \leq 25^\circ\text{C}$ POWER RATING	DERATING FACTOR ABOVE $T_A = 25^\circ\text{C}$	$T_A = 70^\circ\text{C}$ POWER RATING
D	950 mW	7.6 mW/°C	608 mW
N	1150 mW	9.2 mW/°C	736 mW

**recommended operating conditions**

	MIN	NOM	MAX	UNIT
Supply voltage, $V_{CC}$	4.5	5	5.95	V
High-level input voltage, $V_{IH}$	2			V
Low-level input voltage, $V_{IL}$			0.8	V
High-level output current, $I_{OH}$			-59.3	mA
Operating free-air temperature, $T_A$	0		70	°C

**electrical characteristics over recommended operating free-air temperature range**

PARAMETER		TEST CONDITIONS		MIN	MAX	UNIT
$V_{IK}$	Input clamp voltage	A, G	$V_{CC} = 4.5\text{ V}$ , $I_I = -18\text{ mA}$		-1.5	V
$V_{OH}$	High-level output voltage	Y	$V_{CC} = 4.5\text{ V}$ , $I_{OH} = -59.3\text{ mA}$ , $V_{IH} = 2\text{ V}$	3.11		V
		Y	$V_{CC} = 5.25\text{ V}$ , $I_{OH} = -41\text{ mA}$ , $V_{IH} = 2\text{ V}$	3.9		
		$\bar{F}$	$V_{CC} = 4.5\text{ V}$ , $I_{OH} = -400\text{ }\mu\text{A}$ , $V_{IH} = 2\text{ V}$	2.5		
$V_{OL}$	Low-level output voltage	Y	$V_{CC} = 5.5\text{ V}$ , $I_{OL} = -240\text{ }\mu\text{A}$ , $V_{IL} = 0.8\text{ V}$		0.15	V
		Y	$V_{CC} = 5.95\text{ V}$ , $I_{OL} = -1\text{ mA}$ , $V_{IL} = 0.8\text{ V}$		0.15	
		$\bar{F}$	$V_{CC} = 4.5\text{ V}$ , $I_{OL} = 8\text{ mA}$ , Y at 0 V, $V_{IH} = 2\text{ V}$		0.5	
$I_{O(off)}$	Off-state output current	Y	$V_{CC} = 4.5\text{ V}$ , $V_I = 0$ , $V_O = 3.11\text{ V}$		100	$\mu\text{A}$
		Y	$V_{CC} = 0$ , $V_I = 0$ , $V_O = 3.11\text{ V}$		200	
$I_I$	Input current	A	$V_{CC} = 4.5\text{ V}$ , $V_I = 2.7\text{ V}$		100	$\mu\text{A}$
		G		200		
$I_{IH}$	High-level input current	A	$V_{CC} = 4.5\text{ V}$ , $V_I = 2.7\text{ V}$		20	$\mu\text{A}$
		G		40		
$I_{IL}$	Low-level input current	A	$V_{CC} = 5.95\text{ V}$ , $V_I = 0.4\text{ V}$		-250	$\mu\text{A}$
		G		-500		
$I_{OS}$	Short-circuit output current	Y	$V_{CC} = 5.5\text{ V}$ , $V_O = 0$ , $V_{IH} = 2.7\text{ V}$		-5	mA
		$\bar{F}$	$V_{CC} = 5.5\text{ V}$ , $V_O = 0$	-15	-100	
		Y	$V_{CC} = 5.95\text{ V}$ , $V_O = 0$ , $V_{IH} = 2.7\text{ V}$		-5	
		$\bar{F}$	$V_{CC} = 5.95\text{ V}$ , $V_O = 0$	-15	-110	
$I_{CCH}$	Supply current, all outputs high		$V_{CC} = 5.5\text{ V}$ , No load, $V_{IH} = 2\text{ V}$		70	mA
			$V_{CC} = 5.95\text{ V}$ , No load, $V_{IH} = 2\text{ V}$		80	
$I_{CCL}$	Supply current, Y outputs low		$V_{CC} = 5.5\text{ V}$ , No load, $V_{IL} = 0.8\text{ V}$		55	mA
			$V_{CC} = 5.95\text{ V}$ , No load, $V_{IL} = 0.8\text{ V}$		70	

# SN75126 QUADRUPLE LINE DRIVER

SLLS060B – FEBRUARY 1990 – REVISED MAY 1995

## switching characteristics at $T_A = 25^\circ\text{C}$

PARAMETER	FROM (INPUT)	TO (OUTPUT)	TEST CONDITIONS	MIN	MAX	UNIT
$t_{PLH}$ Propagation delay time, low- to high-level output	A	Y	$V_{CC} = 4.5\text{ V to } 5.5\text{ V}$ , $R_L = 50\ \Omega$ , $C_L = 50\text{ pF}$ , $V_{OH(ref)} = 3.11\text{ V}$ , See Figures 1 and 2		40	ns
$t_{PHL}$ Propagation delay time, high- to low-level output					37	ns
$\frac{t_{PLH}}{t_{PHL}}$ Ratio of propagation delay times					0.3	3
$t_{PLH}$ Propagation delay time, low- to high-level output	A	Y	$V_{CC} = 5.25\text{ V to } 5.95\text{ V}$ , $R_L = 90\ \Omega$ , $C_L = 50\text{ pF}$ , $V_{OH(ref)} = 3.9\text{ V}$ , See Figures 1 and 2		45	ns
$t_{PHL}$ Propagation delay time, high- to low-level output					45	ns
$t_{PLH}$ Propagation delay time, low- to high-level output	A	$\bar{F}$	$V_{CC} = 5\text{ V}$ , $C_L = 15\text{ pF}$ , $R_L = 2\text{ k}\Omega$ , See Figures 1 and 2		60	ns
$t_{PHL}$ Propagation delay time, high- to low-level output					100	ns

### PARAMETER MEASUREMENT INFORMATION

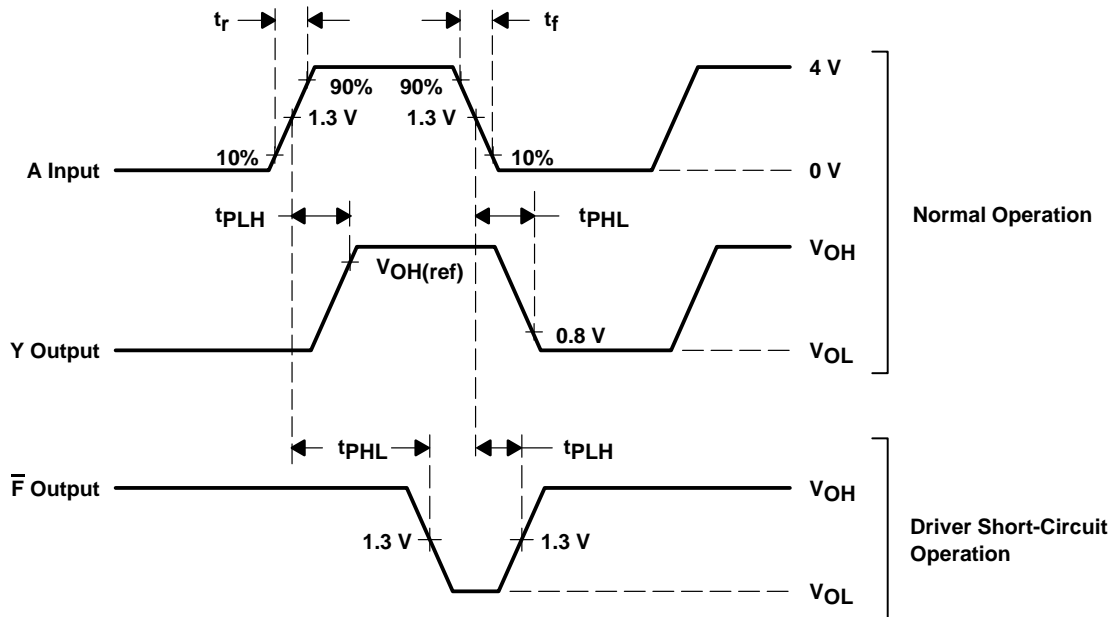

NOTE: The input pulse is supplied by a generator having the following characteristics:  $PRR \leq 1\text{ MHz}$ , duty cycle  $\leq 50\%$ ,  $t_r \leq 6\text{ ns}$ ,  $t_f \leq 6\text{ ns}$ ,  $Z_O \approx 50\ \Omega$ .

Figure 1. Input and Output Voltage Waveforms

PARAMETER MEASUREMENT INFORMATION

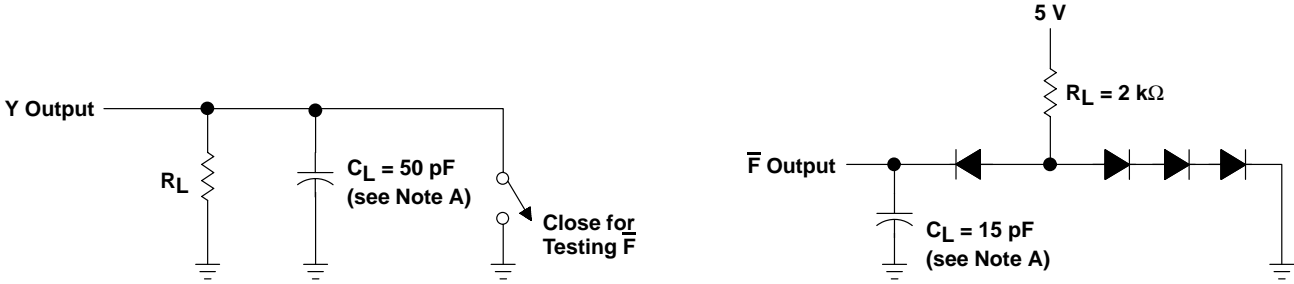

NOTE A:  $C_L$  includes probe and stray capacitance.

Figure 2. Switching Characteristics Load Circuits



## **IMPORTANT NOTICE**

Texas Instruments (TI) reserves the right to make changes to its products or to discontinue any semiconductor product or service without notice, and advises its customers to obtain the latest version of relevant information to verify, before placing orders, that the information being relied on is current.

TI warrants performance of its semiconductor products and related software to the specifications applicable at the time of sale in accordance with TI's standard warranty. Testing and other quality control techniques are utilized to the extent TI deems necessary to support this warranty. Specific testing of all parameters of each device is not necessarily performed, except those mandated by government requirements.

Certain applications using semiconductor products may involve potential risks of death, personal injury, or severe property or environmental damage ("Critical Applications").

**TI SEMICONDUCTOR PRODUCTS ARE NOT DESIGNED, INTENDED, AUTHORIZED, OR WARRANTED TO BE SUITABLE FOR USE IN LIFE-SUPPORT APPLICATIONS, DEVICES OR SYSTEMS OR OTHER CRITICAL APPLICATIONS.**

Inclusion of TI products in such applications is understood to be fully at the risk of the customer. Use of TI products in such applications requires the written approval of an appropriate TI officer. Questions concerning potential risk applications should be directed to TI through a local SC sales office.

In order to minimize risks associated with the customer's applications, adequate design and operating safeguards should be provided by the customer to minimize inherent or procedural hazards.

TI assumes no liability for applications assistance, customer product design, software performance, or infringement of patents or services described herein. Nor does TI warrant or represent that any license, either express or implied, is granted under any patent right, copyright, mask work right, or other intellectual property right of TI covering or relating to any combination, machine, or process in which such semiconductor products or services might be or are used.