

LT1039 TRIPLE EIA-232 LINE TRANSCEIVER

SLLS105B – D3627, FEBRUARY 1991 – REVISED JANUARY 1992

- Meets All EIA-232-D (Revision of RS-232-C) Specifications
- Three Independent Drivers and Receivers Per Package
- EIA-232 Inputs and Outputs Withstand ± 30 V
- 3-State Outputs
- All Outputs Are Short-Circuit Protected
- Virtually Zero Supply Current When Shutdown
- Output of Several Devices Can Be Paralleled
- Operates From ± 5 -V to ± 15 -V Supplies
- Designed to Be Interchangeable With Linear Technology LT1039

DW OR N PACKAGE
(TOP VIEW)

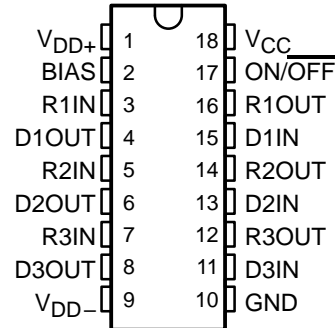

description

The LT1039 is a triple EIA-232 line transceiver designed to meet the requirements of Standard EIA-232-D. All outputs are fully protected against an overload or short to ground. A major advantage of the LT1039 is high-impedance output states when the device is off or powered down. This feature allows several different devices to be connected together on the same bus.

The bias pin provides a receiver to be kept alive when the LT1039 is shutdown ($\overline{\text{ON/OFF}} = \text{low}$).

The LT1039 is characterized for operation from 0°C to 70°C .

AVAILABLE OPTIONS

T _A	PACKAGE	
	SMALL OUTLINE (DW)	PLASTIC DIP (N)
0°C to 70°C	LT1039CDW	LT1039CN

The DW package is available taped and reeled. Add the suffix R to the device type (i.e., LT1039CDWR).

LT1039 TRIPLE EIA-232 LINE TRANSCEIVER

SLLS105B – D3627, FEBRUARY 1991 – REVISED JANUARY 1992

logic symbol†

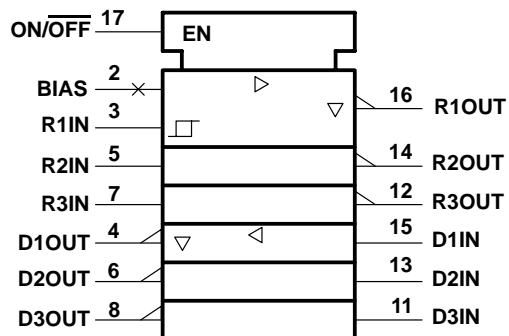

† This symbol is in accordance with ANSI/IEEE Std 91-1984 and IEC Publication 617-12.

logic diagram

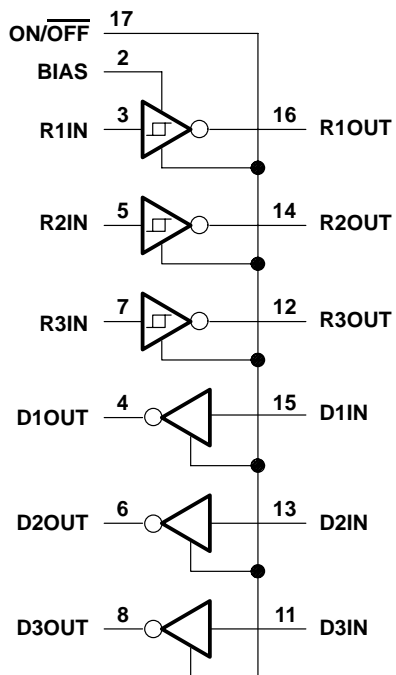

Terminal Functions

PIN NAME	NO.	DESCRIPTION
BIAS	2	Keeps receiver 1 alive while the LT1039 is in the shutdown mode. Leave BIAS open when not in use.
D1IN, D2IN, D3IN	15, 13, 11	Line driver inputs. Operate properly on TTL or CMOS levels. Output valid from $V_I = (V_{DD-}) + (2 \text{ to } 15 \text{ V})$. Connect to 5 V when not used.
D1OUT, D2OUT, D3OUT	4, 6, 8	Line driver outputs
GND	10	Ground
ON/OFF	17	Shuts down entire circuit. Cannot be left open. If V_{IL} is at or near 0.8 V, significant settling time may be required.
R1IN, R2IN, R3IN	3, 5, 7	Receiver inputs. Input impedance is normally 30 k Ω . Accepts EIA-232 voltage levels and has 0.4 V of hysteresis to provide noise immunity.
R1OUT, R2OUT, R3OUT	16, 14, 12	Receiver outputs with TTL/CMOS voltage levels
V_{DD+}	1	Positive supply voltage for driver
V_{DD-}	9	Negative supply voltage for driver
V_{CC}	18	5-V supply voltage for receivers

absolute maximum ratings over operating free-air temperature range (unless otherwise noted)

Supply voltage range, V_{DD+} (see Note 1)	0 V to 15 V
Supply voltage range, V_{DD-}	0 V to -15 V
Supply voltage, V_{CC}	7 V
Input voltage range, driver input	V_{DD-} to 25 V
receiver input	± 30 V
Input voltage range, ON/OFF	0 V to 12 V
Output voltage range, driver output	$V_{DD+} - 30$ V to $V_{DD-} + 30$ V
Duration of output short circuit at (or below) $T_A = 25^\circ\text{C}$ (to ± 30 V, see Note 2)	unlimited
Continuous total dissipation	See Dissipation Rating Table
Operating free-air temperature range, T_A	0°C to 70°C
Storage temperature range	-65°C to 150°C
Lead temperature 1,6 mm (1/16 inch) from case for 10 seconds	260°C

NOTES: 1. All voltage values, except differential voltages, are with respect to the GND terminal.

2. The output may be shorted to either supply. Temperature and/or supply voltages must be limited to ensure that the maximum dissipation rating is not exceeded.

DISSIPATION RATING TABLE

PACKAGE	$T_A \leq 25^\circ\text{C}$ POWER RATING	DERATING FACTOR ABOVE $T_A = 25^\circ\text{C}$	$T_A = 70^\circ\text{C}$ POWER RATING
DW	1025 mW	8.2 mW/°C	656 mW
N	1150 mW	9.2 mW/°C	736 mW

LT1039

TRIPLE EIA-232 LINE TRANSCEIVER

SLLS105B – D3627, FEBRUARY 1991 – REVISED JANUARY 1992

recommended operating conditions

	MIN	NOM	MAX	UNIT
Supply voltage, V_{DD+}	5	12	15	V
Supply voltage, V_{DD-}	-5	-12	-15	V
Supply voltage, V_{CC}	4.75	5	5.25	V
High-level input voltage, V_{IH} (see Note 3)	2			V
Low-level input voltage, V_{IL} (see Note 3)			0.8	V
Operating free-air temperature, T_A	0		70	°C

NOTE 3: V_{IH} and V_{IL} specifications apply only for inputs D11N to D31N.

DRIVER SECTION

electrical characteristics over recommended operating free-air temperature range, $V_{DD\pm} = \pm 11.4$ V to ± 12.6 V, ON/OFF at 2.5 V (unless otherwise noted)

PARAMETER	TEST CONDITIONS	MIN	TYP†	MAX	UNIT
V_{OM+} Maximum positive peak output voltage swing	Load = 3 k Ω to GND	$V_{DD+} - 0.4$	$V_{DD+} - 0.4$		V
V_{OM-} Maximum negative peak output voltage swing		$V_{DD-} + 1.0$	$V_{DD-} + 1.5$		
I_{IH} High-level input current	$V_I \geq 2$ V		1	20	μ A
I_{IL} Low-level input current	$V_I \leq 0.8$ V		5	20	μ A
	$V_I = 0$			15	
	$V_I = 5$ V			80	
	Sourcing current, $V_O = 0$	5	15		
	Sinking current, $V_O = 0$	-5	-15		
I_{OZ} Off-state output current	$V_O = \pm 18$ V, $V_I = 0$, ON/OFF at 0.4 V		± 10	± 200	μ A
I_{CC} Supply current	$I_O = 0$		4	8	mA
$I_{CC(off)}$ Off-state supply current	ON/OFF at 0.4 V		1	100	μ A
SR Slew rate	$R_L = 3$ k Ω , $C_L = 51$ pF	4	15	30	V/ μ s

† All typical values are at $V_{DD\pm} = \pm 12$ V, $T_A = 25^\circ$ C.

RECEIVER SECTION

electrical characteristics over recommended ranges of supply voltage and operating free-air temperature, ON/OFF at 2.5 V (unless otherwise noted)

PARAMETER		TEST CONDITIONS	MIN	TYP†	MAX	UNIT
V_{T-}	Negative-going input threshold voltage		0.5	1.3		V
V_{T+}	Positive-going input threshold voltage			1.7	2.8	V
V_{hys}	Hysteresis ($V_{T+} - V_{T-}$)		0.1	0.4	1	V
V_{OL}	Low-level output voltage	$I_O = -1.6$ mA		0.4	0.5	V
V_{OH}	High-level output voltage	$I_O = 160$ μ A	3.5	4.8		V
I_{OS}	Short-circuit output current	Sinking current, $V_O = V_{CC}$	-10			mA
		Sourcing current, $V_O = 0$	0.5	1		
I_{OZ}	Off-state (high-impedance state) output current	$V_O = 0$ to V_{CC} , $V_I = 0$, ON/OFF at 0.4 V		± 1	± 10	μ A
I_{CC}	Supply current	$I_O = 0$		4	7	mA
$I_{CC(off)}$	Off-state supply current	ON/OFF at 0.4 V		1	100	μ A

† All typical values ground are at $V_{CC} = 5$ V, $T_A = 25^\circ$ C.

IMPORTANT NOTICE

Texas Instruments (TI) reserves the right to make changes to its products or to discontinue any semiconductor product or service without notice, and advises its customers to obtain the latest version of relevant information to verify, before placing orders, that the information being relied on is current.

TI warrants performance of its semiconductor products and related software to the specifications applicable at the time of sale in accordance with TI's standard warranty. Testing and other quality control techniques are utilized to the extent TI deems necessary to support this warranty. Specific testing of all parameters of each device is not necessarily performed, except those mandated by government requirements.

Certain applications using semiconductor products may involve potential risks of death, personal injury, or severe property or environmental damage ("Critical Applications").

TI SEMICONDUCTOR PRODUCTS ARE NOT DESIGNED, INTENDED, AUTHORIZED, OR WARRANTED TO BE SUITABLE FOR USE IN LIFE-SUPPORT APPLICATIONS, DEVICES OR SYSTEMS OR OTHER CRITICAL APPLICATIONS.

Inclusion of TI products in such applications is understood to be fully at the risk of the customer. Use of TI products in such applications requires the written approval of an appropriate TI officer. Questions concerning potential risk applications should be directed to TI through a local SC sales office.

In order to minimize risks associated with the customer's applications, adequate design and operating safeguards should be provided by the customer to minimize inherent or procedural hazards.

TI assumes no liability for applications assistance, customer product design, software performance, or infringement of patents or services described herein. Nor does TI warrant or represent that any license, either express or implied, is granted under any patent right, copyright, mask work right, or other intellectual property right of TI covering or relating to any combination, machine, or process in which such semiconductor products or services might be or are used.