

- **Single Chip With Easy Interface Between UART and Serial-Port Connector of an External Modem or Other Computer Peripheral**
- **Five Drivers and Three Receivers Meet or Exceed the Requirements of TIA/EIA-232-F and ITU Recommendation V.28**
- **Designed to Support Data Rates up to 120 kbit/s**
- **ESD Protection Meets Or Exceeds 10 kV on RS-232 Pins and 5 kV on All Other Pins (Human-Body Model)**
- **Complement to the SN75185**
- **Pin-to-Pin Replacement for the Goldstar GD75323**
- **Functional Replacement for the MC145405**

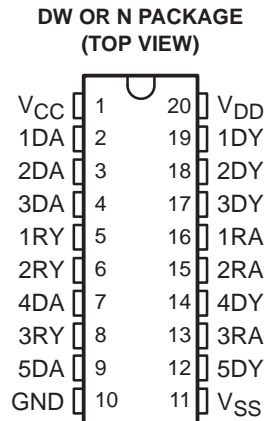

description

The SN75196 combines five drivers and three receivers from the trade-standard SN75188 and SN75189 bipolar quadruple drivers and receivers, respectively. The flow-through design of the SN75196 decreases the part count, reduces the board space required, and allows easy interconnection of the UART and serial-port connector. The all-bipolar circuits and processing of the SN75196 provide a rugged, low-cost solution for this function.

The SN75196 complies with the requirements of TIA/EIA-232-F and ITU (formerly CCITT) V.28 standards. These standards are for data interchange between a host computer and peripheral at signal rates of up to 20 kbit/s. The switching speeds of the SN75196 are fast enough to support rates of up to 120 kbit/s with lower capacitive loads (shorter cables). Interoperability at the higher signaling rates cannot be assured unless the designer has design control of the cable and the interface circuits at both ends. For interoperability at signaling rates of up to 120 kbit/s, use of TIA/EIA-423-B (ITU V.10) and TIA/EIA-422-B (ITU V.11) standards are recommended.

The SN75196 is characterized for operation over a temperature range of 0°C to 70°C.



Please be aware that an important notice concerning availability, standard warranty, and use in critical applications of Texas Instruments semiconductor products and disclaimers thereto appears at the end of this data sheet.

PRODUCTION DATA information is current as of publication date. Products conform to specifications per the terms of Texas Instruments standard warranty. Production processing does not necessarily include testing of all parameters.

**TEXAS
INSTRUMENTS**

POST OFFICE BOX 655303 • DALLAS, TEXAS 75265

Copyright © 1998, Texas Instruments Incorporated

SN75196

MULTIPLE RS-232 DRIVERS AND RECEIVERS

SLLS188B – MAY 1995 – REVISED APRIL 1998

logic symbol†

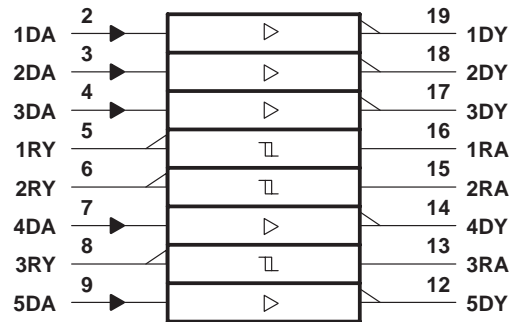

† This symbol is in accordance with ANSI/IEEE Std 91-1984 and IEC Publication 617-12.

logic diagram (positive logic)

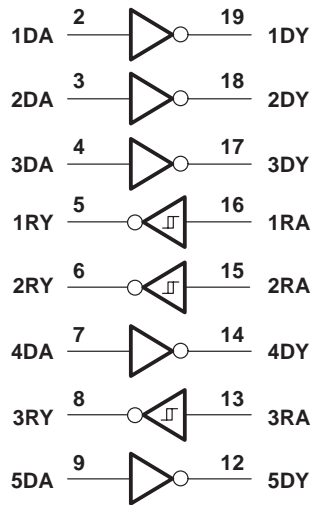

schematic of each driver

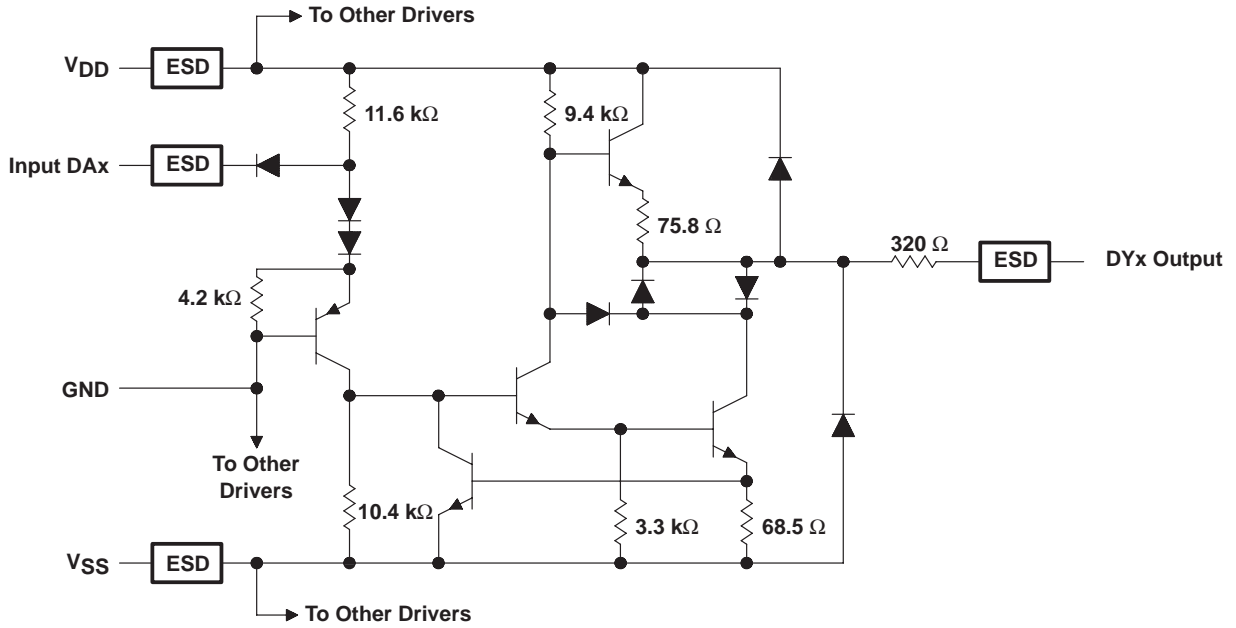

Resistor values shown are nominal.

schematic of each receiver

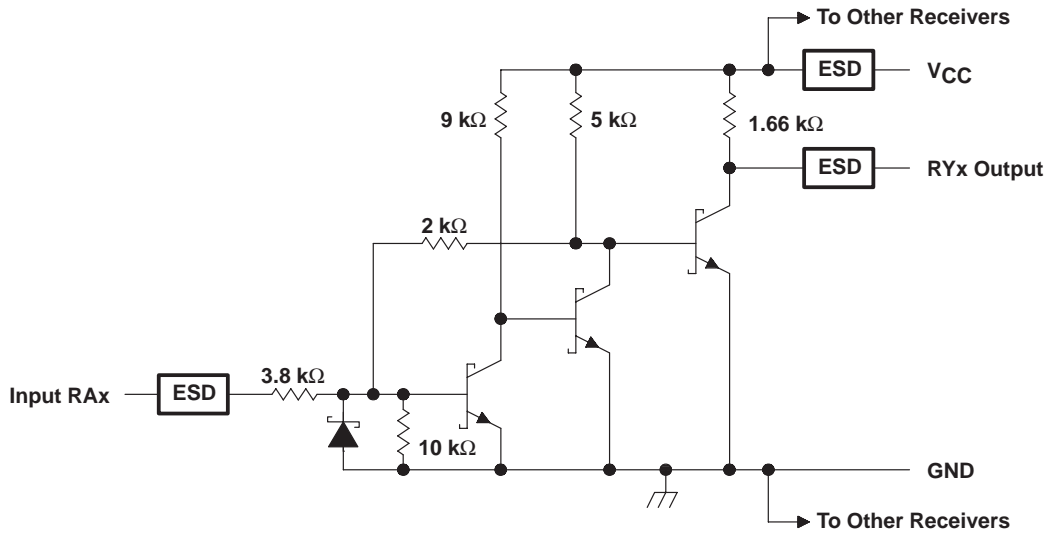

Resistor values shown are nominal.

SN75196 MULTIPLE RS-232 DRIVERS AND RECEIVERS

SLLS188B – MAY 1995 – REVISED APRIL 1998

absolute maximum ratings over operating free-air temperature (unless otherwise noted)†

Supply voltage, V_{CC} (see Note 1)	10 V
Supply voltage, V_{DD} (see Note 1)	15 V
Supply voltage, V_{SS} (see Note 1)	-15 V
Input voltage range, V_i : Driver	-15 V to 7 V
Receiver	-30 V to 30 V
Output voltage range, V_O (Driver)	-15 V to 15 V
Low-level output current, I_{OL} (Receiver)	20 mA
Continuous total power dissipation	See Dissipation Rating Table
Electrostatic discharge: DY and RA to GND (see Note 2)	Class 3, A: 10 kV, B: 500 V
All pins (see Note 2)	Class 3, A: 5 kV, B: 300 V
Storage temperature range, T_{stg}	-65°C to 150°C
Lead temperature 1,6 mm (1/16 inch) from case for 10 seconds	260°C

† Stresses beyond those listed under "absolute maximum ratings" may cause permanent damage to the device. These are stress ratings only, and functional operation of the device at these or any other conditions beyond those indicated under "recommended operating conditions" is not implied. Exposure to absolute-maximum-rated conditions for extended periods may affect device reliability.

- NOTES: 1. All voltages are with respect to the network ground terminal.
2. Per MIL-PRF-38535, Method 3015.7

DISSIPATION RATING TABLE

PACKAGE	$T_A \leq 25^\circ\text{C}$ POWER RATING	DERATING FACTOR‡ ABOVE $T_A = 25^\circ\text{C}$	$T_A = 70^\circ\text{C}$ POWER RATING
DW	1125 mW	9.0 mW/°C	720 mW
N	1150 mW	9.2 mW/°C	736 mW

‡ This is the inverse of the traditional junction-to-case thermal resistance ($R_{\theta JA}$).

recommended operating conditions

		MIN	NOM	MAX	UNIT
Supply voltage, V_{DD}		7.5	9	13.5	V
Supply voltage, V_{SS}		-7.5	-9	-13.5	V
Supply voltage, V_{CC}		4.5	5	5.5	V
High-level input voltage, V_{IH}	Driver	1.9			V
Low-level input voltage, V_{IL}	Driver			0.8	V
High-level output current, I_{OH}	Driver			-6	mA
	Receiver			-0.5	
High-level output current, I_{OL}	Driver			6	mA
	Receiver			16	
Operating free-air temperature, T_A		0		70	°C



supply currents over operating free-air temperature range

PARAMETER		TEST CONDITIONS			MIN	MAX	UNIT
I _{DD}	Supply current from V _{DD}	All inputs at 1.9 V, No load	V _{DD} = 9 V, V _{SS} = -9 V			25	mA
			V _{DD} = 12 V, V _{SS} = -12 V			32	
		All inputs at 0.8 V, No load	V _{DD} = 9 V, V _{SS} = -9 V			7.5	
			V _{DD} = 12 V, V _{SS} = -12 V			9.5	
I _{SS}	Supply current from V _{SS}	All inputs at 1.9 V, No load	V _{DD} = 9 V, V _{SS} = -9 V			-25	mA
			V _{DD} = 12 V, V _{SS} = -12 V			-32	
		All inputs at 0.8 V, No load	V _{DD} = 9 V, V _{SS} = -9 V			-5.3	
			V _{DD} = 12 V, V _{SS} = -12 V			-5.3	
I _{CC}	Supply current from V _{CC}	V _{CC} = 5 V, All inputs at 5 V, No load			20	mA	

DRIVER SECTION

electrical characteristics over operating free-air temperature range, V_{DD} = 9 V, V_{SS} = -9 V, V_{CC} = 5 V, (unless otherwise noted)

PARAMETER		TEST CONDITIONS			MIN	TYP	MAX	UNIT
V _{OH}	High-level output voltage	V _{IL} = 0.8 V, R _L = 3 kΩ, See Figure 1			6	7.5		V
V _{OL}	Low-level output voltage (see Note 3)	V _{IH} = 1.9 V, R _L = 3 kΩ, See Figure 1				-7.5	-6	V
I _{IH}	High-level input current	V _I = 5 V, See Figure 2					10	μA
I _{IL}	Low-level input current	V _I = 0, See Figure 2					-1.6	mA
I _{OS(H)}	High-level short-circuit output current (see Note 4)	V _{IL} = 0.8 V, V _O = 0, See Figure 1			-4.5	-9	-19.5	mA
I _{OS(L)}	Low-level short-circuit output current (see Note 4)	V _{IH} = 2 V, V _O = 0, See Figure 1			4.5	9	19.5	mA
r _o	Output resistance (see Note 5)	V _{CC} = V _{DD} = V _{SS} = 0, V _O = -2 V to 2 V			300			Ω

- NOTES: 3. The algebraic convention, where the more positive (less negative) limit is designated as maximum, is used in this data sheet for logic levels only, e.g., if -10 V is a maximum, the typical value is a more negative voltage.
 4. Output short-circuit conditions must maintain the total power dissipation below absolute maximum ratings.
 5. Test conditions are those specified by TIA/EIA-232-F and as listed above.

switching characteristics, V_{DD} = 12 V, V_{SS} = -12 V, V_{CC} = 5 V ±10%, T_A = 25°C

PARAMETER		TEST CONDITIONS			MIN	TYP	MAX	UNIT
t _{PLH}	Propagation delay time, low- to high-level output	R _L = 3 kΩ to 7 kΩ, C _L = 15 pF, See Figure 3				315	500	ns
t _{PHL}	Propagation delay time, high- to low-level output	R _L = 3 kΩ to 7 kΩ, C _L = 15 pF, See Figure 3				75	175	ns
t _{TLH}	Transition time, low- to high-level output (see Note 6)	R _L = 3 kΩ to 7 kΩ	C _L = 15 pF, See Figure 3			60	100	ns
			C _L = 2500 pF, See Figure 3 and Note 6			1.7	2.5	μs
t _{THL}	Transition time, high- to low-level output (see Note 7)	R _L = 3 kΩ to 7 kΩ	C _L = 15 pF, See Figure 3			40	75	ns
			C _L = 2500 pF, See Figure 3 and Note 7			1.5	2.5	μs

- NOTES: 6. Measured between -3-V and 3-V points of the output waveform (TIA/EIA-232-F conditions), all unused inputs are tied either high or low.
 7. Measured between 3-V and -3-V points of the output waveform (TIA/EIA-232-F conditions), all unused inputs are tied either high or low.

SN75196 MULTIPLE RS-232 DRIVERS AND RECEIVERS

SLLS188B – MAY 1995 – REVISED APRIL 1998

RECEIVER SECTION

electrical characteristics over recommended operating conditions (unless otherwise noted)

PARAMETER		TEST CONDITIONS		MIN	TYP†	MAX	UNIT
V _{IT+}	Positive-going input threshold voltage	See Figure 5	T _A = 25°C	1.75	1.9	2.3	V
			T _A = 0°C to 70 °C	1.55		2.3	
V _{IT-}	Negative-going input threshold voltage	See Figure 5		0.75	0.97	1.25	V
V _{hys}	Input hysteresis (V _{IT+} - V _{IT-})	See Figure 5		0.5			V
V _{OH}	High-level output voltage	I _{OH} = -0.5 mA, See Figure 5	V _{IH} = 0.75 V	2.6	4	5	V
			Inputs open	2.6			
V _{OL}	Low-level input voltage	I _{OL} = 10 mA, V _I = 3 V, See Figure 5			0.2	0.45	V
I _{IH}	High-level input current	V _I = 25 V		3.6		8.3	mA
		V _I = 3 V		0.43			
I _{IL}	Low-level input current	V _I = -25 V		-3.6		-8.3	mA
		V _I = -3 V		-0.43			
I _{OS}	Short-circuit output current	See Figure 4		-3.4		-12	mA

† All typical values are at T_A = 25°C, V_{CC} = 5 V, V_{DD} = 9 V, and V_{SS} = -9 V.

switching characteristics, V_{CC} = 5 V, V_{DD} = 12 V, V_{SS} = -12 V, T_A = 25°C

PARAMETER		TEST CONDITIONS		MIN	TYP	MAX	UNIT
t _{PLH}	Propagation delay time, low- to high-level output	C _L = 50 pF, R _L = 5 kΩ, See Figure 6			107	500	ns
t _{PHL}	Propagation delay time, high- to low-level output	C _L = 50 pF, R _L = 5 kΩ, See Figure 6			42	150	ns
t _{T LH}	Transition time, low- to high-level output	C _L = 50 pF, R _L = 5 kΩ, See Figure 6			175	525	ns
t _{T HL}	Transition time, high- to low-level output	C _L = 50 pF, R _L = 5 kΩ, See Figure 6			16	60	ns



PARAMETER MEASUREMENT INFORMATION

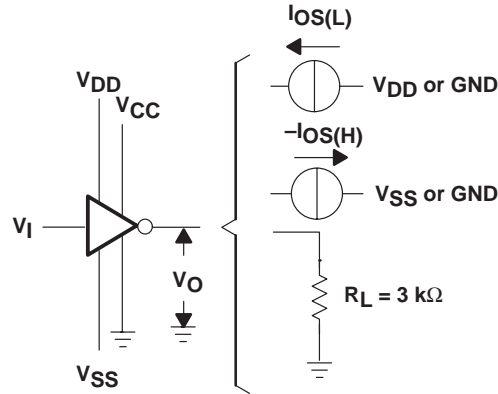

Figure 1. Driver Test Circuit for V_{OH} , V_{OL} , $I_{OS(H)}$, and $I_{OS(L)}$

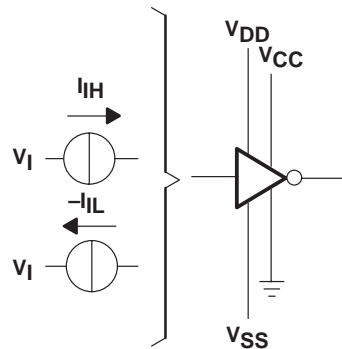
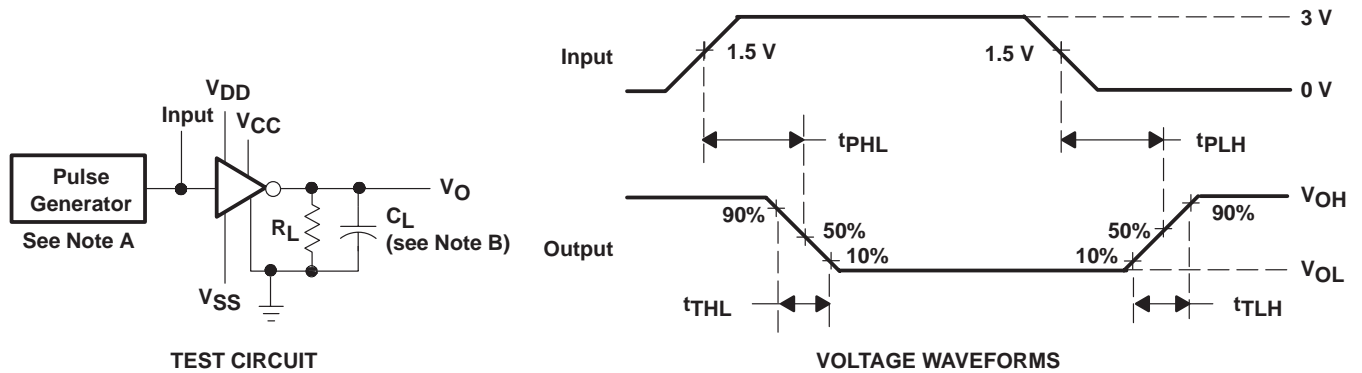

Figure 2. Driver Test Circuit for I_{IH} and I_{IL}



- NOTES: A. The pulse generator has the following characteristics: $t_w = 25\ \mu\text{s}$, $\text{PRR} = 20\ \text{kHz}$, $Z_O = 50\ \Omega$, $t_r = t_f < 50\ \text{ns}$.
 B. C_L includes probe and jig capacitance.

Figure 3. Driver Test Circuit and Voltage Waveforms

SN75196 MULTIPLE RS-232 DRIVERS AND RECEIVERS

SLLS188B – MAY 1995 – REVISED APRIL 1998

PARAMETER MEASUREMENT INFORMATION

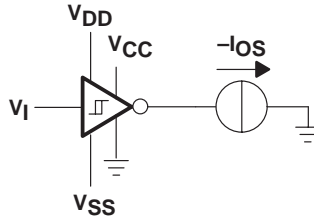

Figure 4. Receiver Test Circuit for I_{OS}

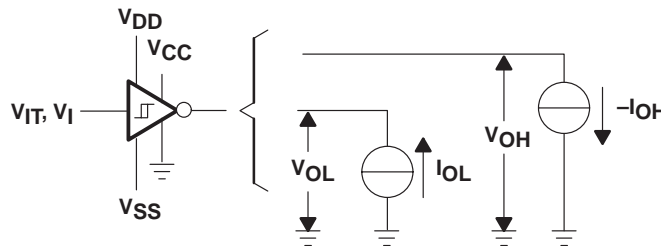
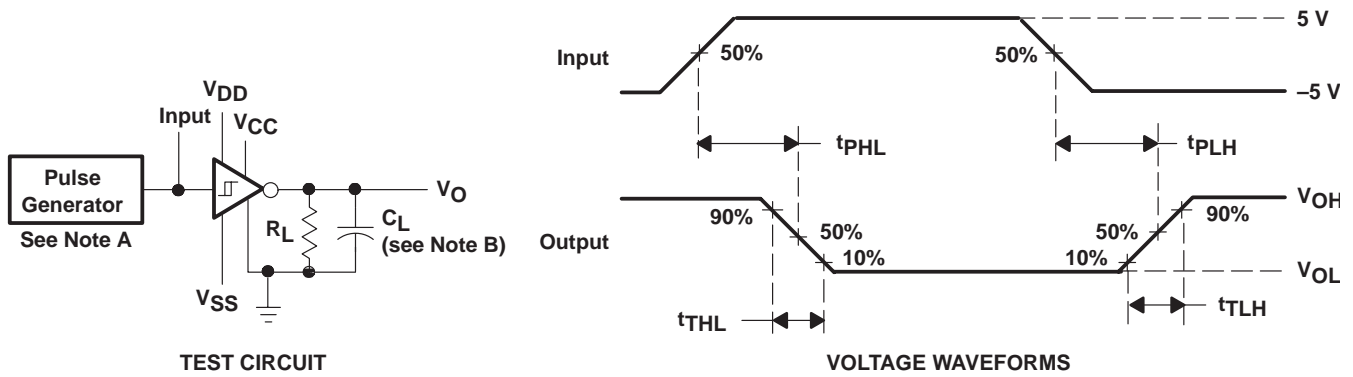

Figure 5. Receiver Test Circuit for V_{IT} , V_{OH} , and V_{OL}



- NOTES: A. The pulse generator has the following characteristics: $t_w = 25 \mu s$, $PRR = 20 \text{ kHz}$, $Z_O = 50 \Omega$, $t_r = t_f < 50 \text{ ns}$.
B. C_L includes probe and jig capacitance.

Figure 6. Receiver Propagation and Transition Times

TYPICAL CHARACTERISTICS

DRIVER SECTION

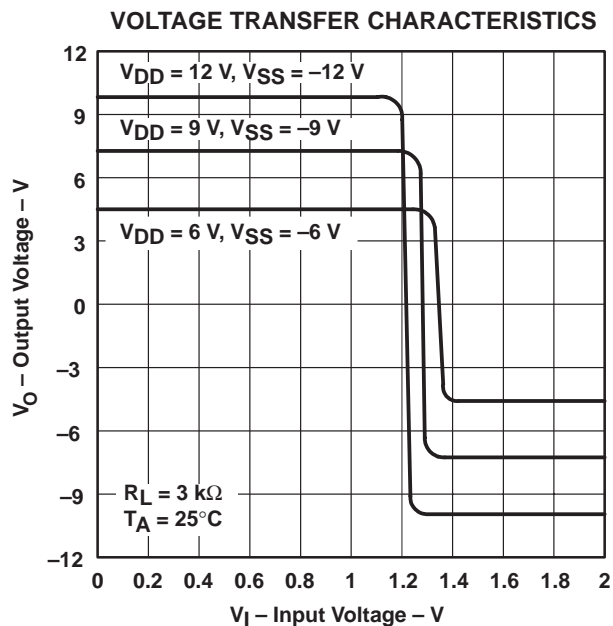

Figure 7

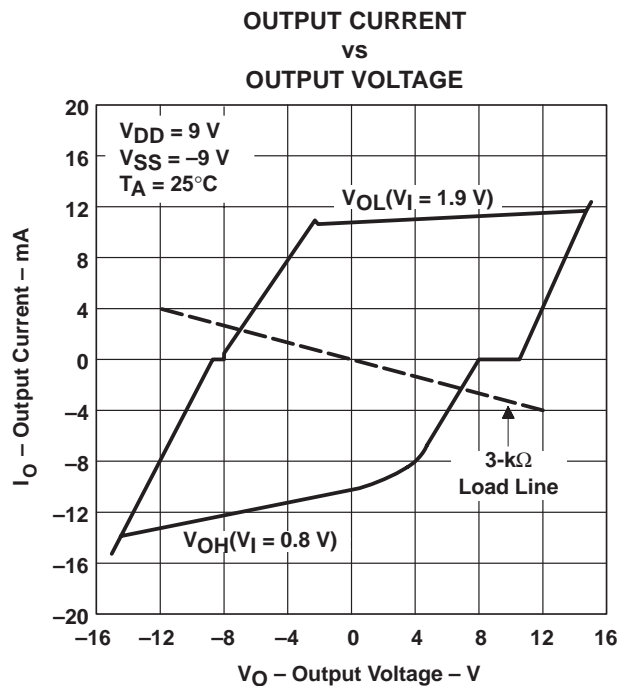

Figure 8

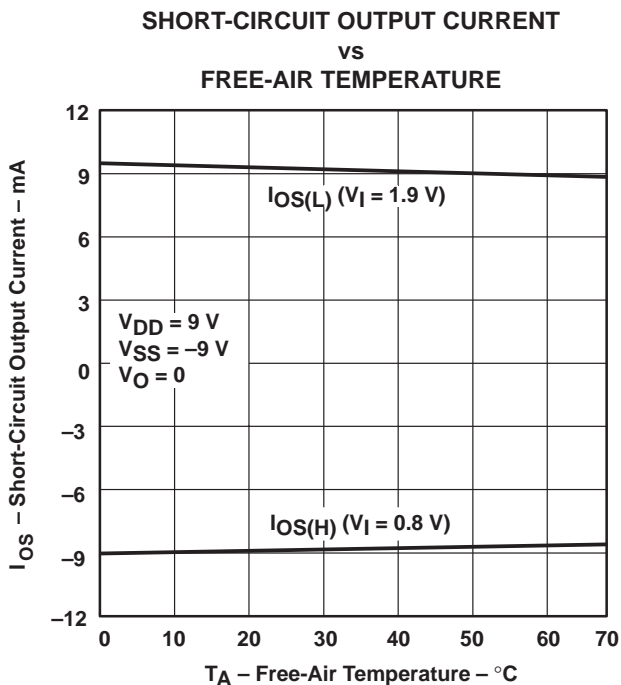

Figure 9

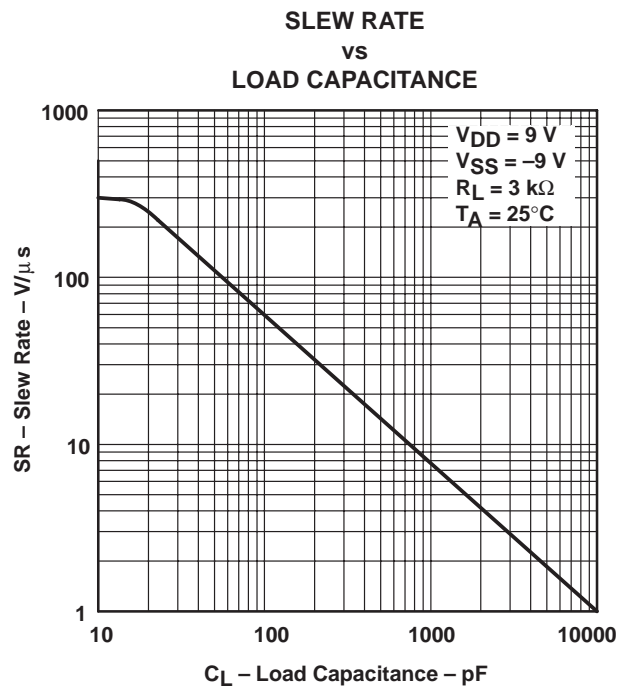

Figure 10

TYPICAL CHARACTERISTICS
 RECEIVER SECTION

INPUT THRESHOLD VOLTAGE
 vs
 FREE-AIR TEMPERATURE

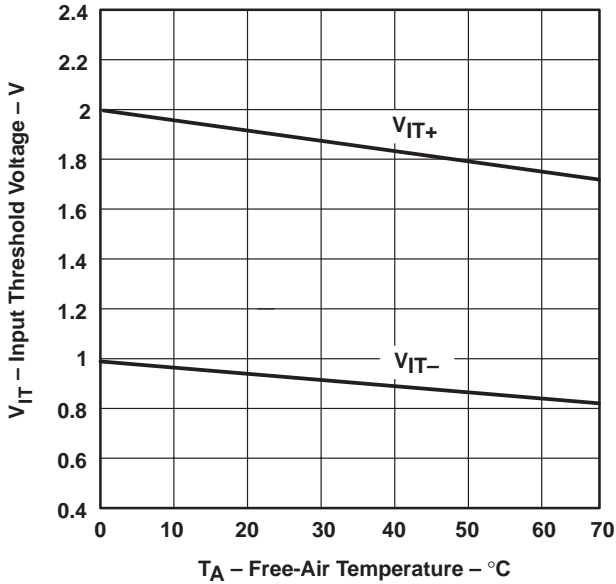

Figure 11

INPUT THRESHOLD VOLTAGE
 vs
 SUPPLY VOLTAGE

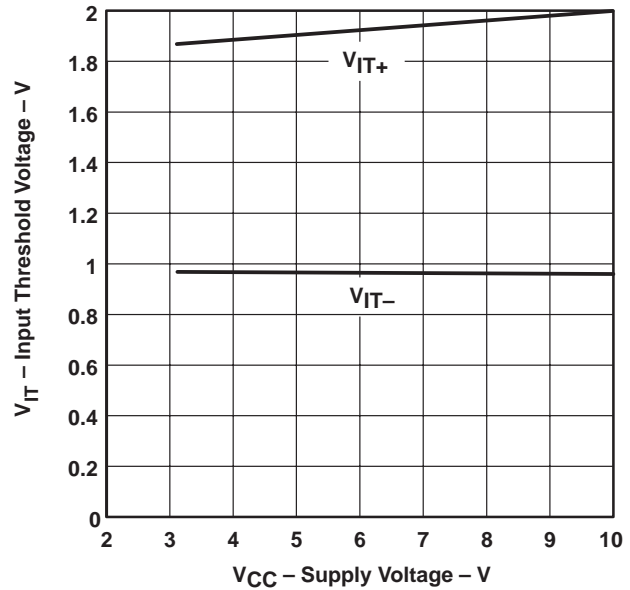
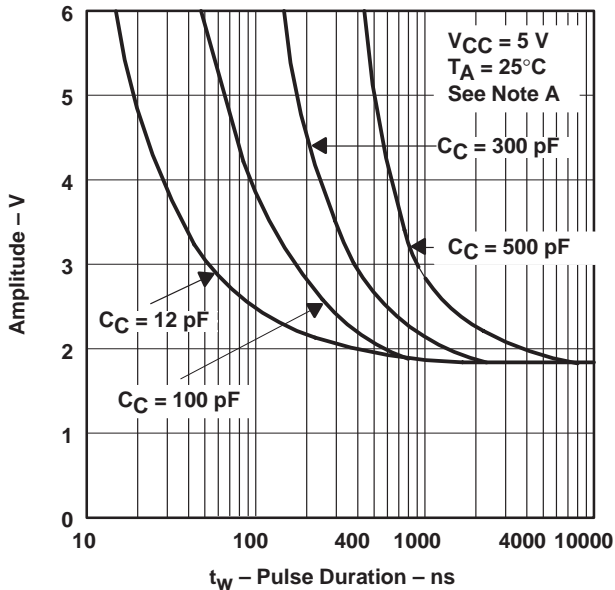

Figure 12

NOISE REJECTION



NOTE A: This figure shows the maximum amplitude of a positive-going pulse that, starting from 0 V, does not cause a change of the output level.

Figure 13

MAXIMUM SUPPLY VOLTAGE
 vs
 FREE-AIR TEMPERATURE

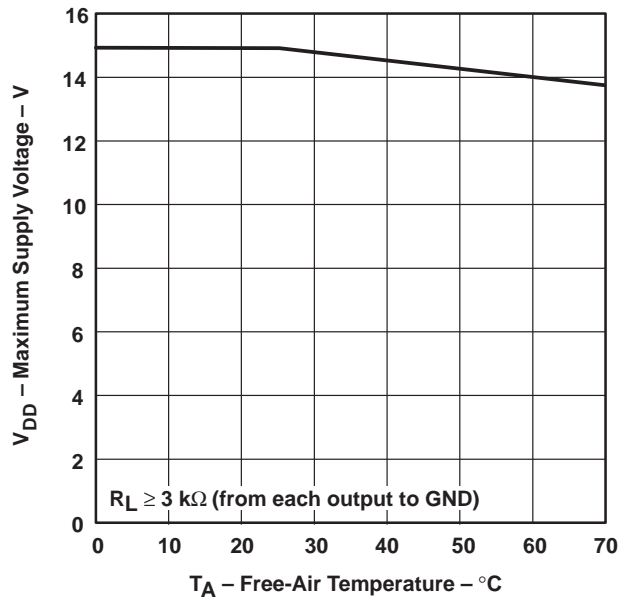

Figure 14

APPLICATION INFORMATION

Diodes placed in series with the V_{DD} and V_{SS} terminals protect the SN75196 in the fault condition when the device outputs are shorted to V_{DD} or V_{SS} and the power supplies are at low and provide low-impedance paths to ground (see Figure 15).

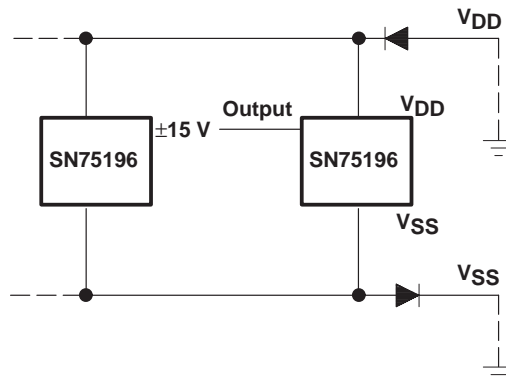
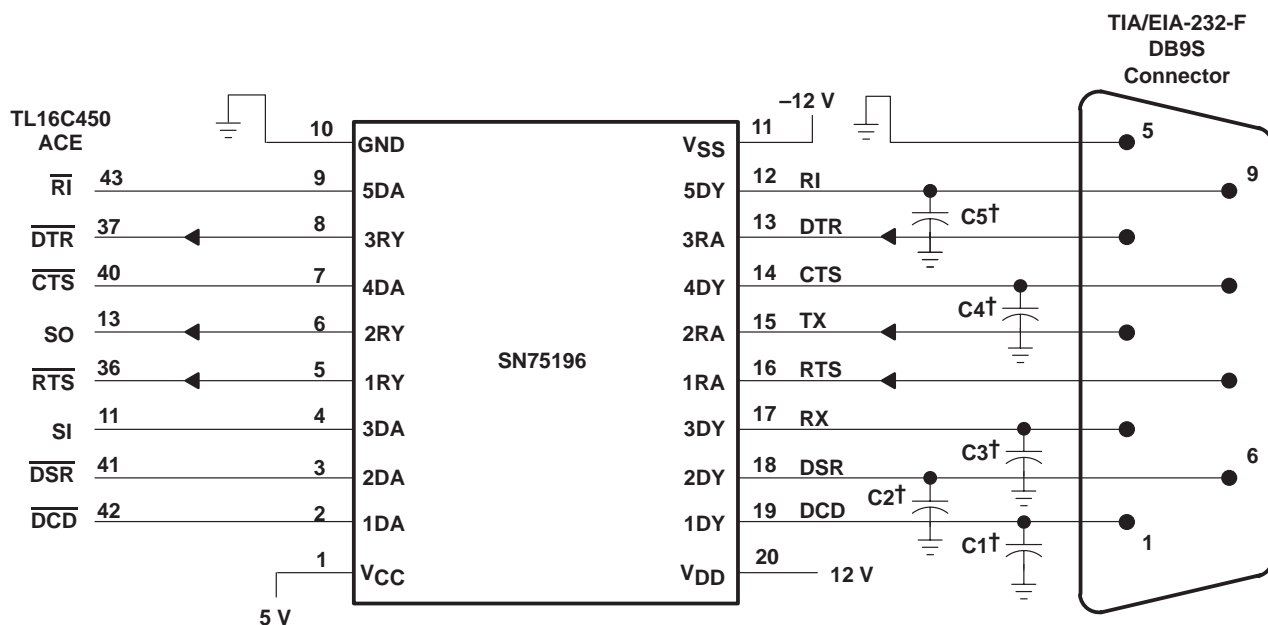

Figure 15. Power-Supply Protection to Meet Power-Off Fault Conditions of TIA/EIA-232-F



† See Figure 10 to select the correct values for the loading capacitors (C1, C2, C3, C4, and C5), which may be required to meet the RS-232 maximum slew-rate requirement of 30 V/μs. The value of the loading capacitors required depends upon the line length and desired slew rate, but is typically 330 pF.

NOTE A: To use the receivers only, V_{DD} and V_{SS} must both be powered or tied to ground.

Figure 16. Typical TIA/EIA-232-F Connection

IMPORTANT NOTICE

Texas Instruments and its subsidiaries (TI) reserve the right to make changes to their products or to discontinue any product or service without notice, and advise customers to obtain the latest version of relevant information to verify, before placing orders, that information being relied on is current and complete. All products are sold subject to the terms and conditions of sale supplied at the time of order acknowledgement, including those pertaining to warranty, patent infringement, and limitation of liability.

TI warrants performance of its semiconductor products to the specifications applicable at the time of sale in accordance with TI's standard warranty. Testing and other quality control techniques are utilized to the extent TI deems necessary to support this warranty. Specific testing of all parameters of each device is not necessarily performed, except those mandated by government requirements.

CERTAIN APPLICATIONS USING SEMICONDUCTOR PRODUCTS MAY INVOLVE POTENTIAL RISKS OF DEATH, PERSONAL INJURY, OR SEVERE PROPERTY OR ENVIRONMENTAL DAMAGE ("CRITICAL APPLICATIONS"). TI SEMICONDUCTOR PRODUCTS ARE NOT DESIGNED, AUTHORIZED, OR WARRANTED TO BE SUITABLE FOR USE IN LIFE-SUPPORT DEVICES OR SYSTEMS OR OTHER CRITICAL APPLICATIONS. INCLUSION OF TI PRODUCTS IN SUCH APPLICATIONS IS UNDERSTOOD TO BE FULLY AT THE CUSTOMER'S RISK.

In order to minimize risks associated with the customer's applications, adequate design and operating safeguards must be provided by the customer to minimize inherent or procedural hazards.

TI assumes no liability for applications assistance or customer product design. TI does not warrant or represent that any license, either express or implied, is granted under any patent right, copyright, mask work right, or other intellectual property right of TI covering or relating to any combination, machine, or process in which such semiconductor products or services might be or are used. TI's publication of information regarding any third party's products or services does not constitute TI's approval, warranty or endorsement thereof.