

# SN75LBC970A SCSI DIFFERENTIAL CONVERTER-CONTROL

SLLS215A – MAY 1995 – REVISED JULY 1996

- Provides Differential SCSI from Single-Ended Controller When Used With the SN75LBC971A Data Transceiver
- Designed to Operate at Fast-SCSI Speeds of 10 Million Data Transfers per Second
- Nine Transceivers Meet or Exceed the Requirements of ANSI Standard EIA-485 and ISO-8482 Standards
- Packaged in Shrink Small-Outline Package with 25 mil Terminal Pitch
- Low Disabled Supply Current  
22 mA Typ
- Thermal Shutdown Protection
- Positive- and Negative-Current Limiting
- Power-Up/-Down Glitch Protection

## description

The SN75LBC970A SCSI differential converter-control is an adaptation of the industry's first 9-channel RS-485 transceiver, the SN75LBC976. When used in conjunction with one or more of its companion data transceiver(s), SN75LBC971A, the chip set provides the superior electrical performance of differential SCSI from a single-ended SCSI bus controller. A 16-bit, Fast-SCSI bus can be implemented with just three devices (two for data and one for control) in the space-efficient, 56-pin, shrink small-outline package (SSOP) and a few external components.

In a typical differential SCSI node, the SCSI controller provides the enables for each external RS-485 transceiver. This could require as many as 27 additional terminals for a 16-bit differential bus controller or relegate a 16-bit single-ended controller to only an 8-bit differential bus. Using the standard nine SCSI control signals, the SN75LBC970A control transceiver decodes the state of the bus and enables the SN75LBC971A data transceiver(s) to transmit the single-ended, SCSI input signals differentially to the cable or receive the differential cable signals and drive the single-ended outputs to the controller.

The single-ended SCSI bus interface consists of CMOS bidirectional inputs and outputs. The drivers are rated at  $\pm 16$  mA of output current. The receiver inputs are pulled high with approximately 4 mA to eliminate the need for external pullup resistors for the open-drain outputs of most single-ended SCSI controllers. The single-ended side of the device is not intended to drive the SCSI bus directly.

DL PACKAGE  
(TOP VIEW)

<u>RSTFLTR</u>	1	56	X2
RESET	2	55	X1/CLK20
DSENS	3	54	NC
CLK40	4	53	BATN-
GND	5	52	BATN+
AATN-	6	51	BACK-
TEST	7	50	BACK+
AACK-	8	49	BREQ-
<u>TIMEOUT</u>	9	48	BREQ+
AREQ-	10	47	BC/D-
AC/D-	11	46	BC/D+
V <sub>CC</sub>	12	45	V <sub>CC</sub>
GND	13	44	GND
GND	14	43	GND
GND	15	42	GND
GND	16	41	GND
GND	17	40	GND
V <sub>CC</sub>	18	39	V <sub>CC</sub>
DRVBUS	19	38	BMSG-
SDB	20	37	BMSG+
AMSG-	21	36	BI/O-
AI/O-	22	35	BI/O+
ASEL-	23	34	BSEL+
NC	24	33	BSEL-
ABSY-	25	32	BBSY+
NC	26	31	BBSY-
ARST-	27	30	BRST+
NC	28	29	BRST-

NC – no internal connection

Terminals 13 through 17 and 40 through 44 are connected together to the package lead frame and signal ground.



Please be aware that an important notice concerning availability, standard warranty, and use in critical applications of Texas Instruments semiconductor products and disclaimers thereto appears at the end of this data sheet.

PRODUCTION DATA information is current as of publication date. Products conform to specifications per the terms of Texas Instruments standard warranty. Production processing does not necessarily include testing of all parameters.



POST OFFICE BOX 655303 • DALLAS, TEXAS 75265

Copyright © 1996, Texas Instruments Incorporated

# SN75LBC970A

## SCSI DIFFERENTIAL CONVERTER-CONTROL

SLLS215A – MAY 1995 – REVISED JULY 1996

### description (continued)

The differential SCSI bus interface consists of bipolar bidirectional inputs and outputs that meet or exceed the requirements of EIA-485 and ISO 8482-1982/TIA TR30.2 referenced by the American National Standard of Information Systems (ANSI) X3.131-1994 Small Computer System Interface-2 (SCSI-2).

The SN75LBC970A is characterized for operation over the temperature range of 0°C to 70°C.

The SN75LBC970A consists of nine RS-485 differential transceivers, nine TTL- or CMOS-level compatible transceivers, a state machine and control logic block, a 20-MHz crystal-controlled oscillator, a timer, a power-up/down glitch protection circuit, and a thermal-shutdown protection circuit.

The single-ended or controller interface is designated as the A side and the differential port is the B side. Since the device uses the SCSI control signals to decode the state of the bus and data flow direction, the terminal assignments must be matched to the corresponding signal on the SCSI bus. The signal name followed by a minus sign (-) indicates an active-low signal while a plus sign (+) indicates an active-high signal.

A reset function, which disables all outputs and clears internal latches, can be accomplished from two external inputs and two internally generated signals.  $\overline{\text{RESET}}$  (Reset) and DSENS (differential sense) are available to external circuits for a bus reset or to disable all outputs should a single-ended cable be inadvertently connected to a differential connector. The power-up and thermal-shutdown are internally generated signals that have the same effect when the supply voltage is below 3.5 V or the junction temperature exceeds approximately 175°C.

This data sheet contains descriptions of the SN75LBC970A input and output signals followed by the electrical characteristics. The parameter measurement information is followed by the theory of operation, a state flow chart, and a typical circuit in the application information section.

### logic diagram (positive logic)

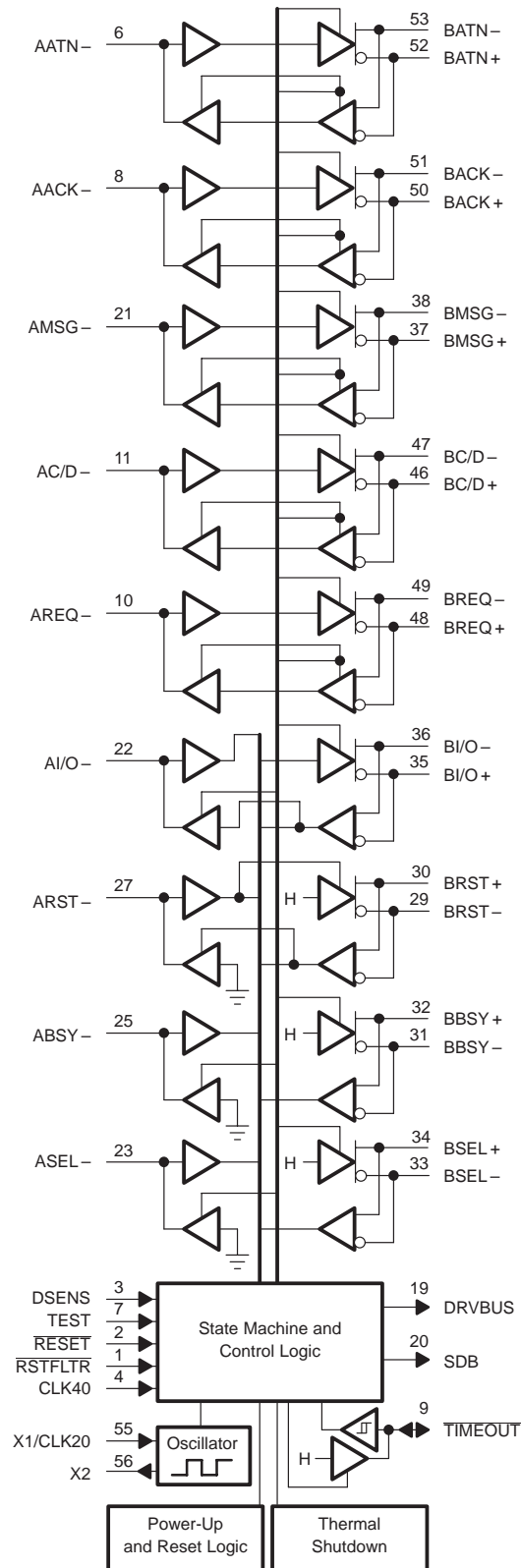

# SN75LBC970A SCSI DIFFERENTIAL CONVERTER-CONTROL

SLLS215A – MAY 1995 – REVISED JULY 1996

## Terminal Functions

TERMINAL NAME	NO.	Logic Level	I/O	Termination	DESCRIPTION
AACK–	8	TTL	I/O	strong pullup	SCSI acknowledge (–ACK) signal to/from controller
AATN–	6	TTL	I/O	strong pullup	SCSI attention (–ATN) signal to/from controller
ABSY–	25	TTL	I/O	strong pullup	SCSI busy (–BSY) signal to/from the controller
AC/D–	11	TTL	I/O	strong pullup	SCSI control/data (–C/D) signal to/from the controller
AI/O–	22	TTL	I/O	strong pullup	SCSI input/output (–I/O) signal to/from the controller
AMSG–	21	TTL	I/O	strong pullup	SCSI message (–MSG) signal to/from the controller
AREQ–	10	TTL	I/O	strong pullup	SCSI request (–REQ) signal to/from controller
ARST–	27	TTL	I/O	strong pullup	SCSI reset (–RST) signal to/from the controller
ASEL–	23	TTL	I/O	strong pullup	SCSI select (–SEL) signal to/from the controller
BACK–	51	RS-485	I/O	weak pullup	SCSI acknowledge (–ACK) signal to/from the bus
BACK+	50	RS-485	I/O	weak pulldown	SCSI acknowledge (+ACK) signal to/from the bus
BATN–	53	RS-485	I/O	weak pullup	SCSI attention (–ATN) signal to/from the bus
BATN+	52	RS-485	I/O	weak pulldown	SCSI attention (+ATN) signal to/from the bus
BBSY–	31	RS-485	I/O	weak pulldown	SCSI busy (–BSY) signal to/from the bus
BBSY+	32	RS-485	I/O	weak pullup	SCSI busy (+BSY) signal to/from the bus
BC/D–	47	RS-485	I/O	weak pullup	SCSI control/data (–C/D) signal to/from the bus
BC/D+	46	RS-485	I/O	weak pulldown	SCSI control/data (+C/D) signal to/from the bus
BI/O–	36	RS-485	I/O	weak pullup	SCSI input/output (–I/O) signal to/from the bus
BI/O+	35	RS-485	I/O	weak pulldown	SCSI input/output (+I/O) signal to/from the bus
BMSG–	38	RS-485	I/O	weak pullup	SCSI message (–MSG) signal to/from the bus
BMSG+	37	RS-485	I/O	weak pulldown	SCSI message (+MSG) signal to/from the bus
BREQ–	49	RS-485	I/O	weak pullup	SCSI request (–REQ) signal to/from the bus
BREQ+	48	RS-485	I/O	weak pulldown	SCSI request (+REQ) signal to/from the bus
BRST–	29	RS-485	I/O	weak pulldown	SCSI reset (–RST) signal to/from the bus
BRST+	30	RS-485	I/O	weak pullup	SCSI reset (+RST) signal to/from the bus
BSEL–	33	RS-485	I/O	weak pulldown	SCSI select (–SEL) signal to/from the bus
BSEL+	34	RS-485	I/O	weak pullup	SCSI select (+SEL) signal to/from the bus
CLK40	4	CMOS	I	strong pulldown	40-MHz clock input
DRVBUS	19	TTL	O	N/A	Driver bus. A high-level logic signal that indicates the SCSI bus is in one of the information transfer phases.
DSENS	3	TTL	I	weak pullup	A low-level input initializes the internal latches and disables all drivers.
GND	5, 13–17, 40–44	N/A	N/A	N/A	Supply common
$\overline{\text{RESET}}$	2	TTL	I	weak pullup	Reset. A low-level input initializes the internal latches and disables all drivers.
$\overline{\text{RSTFLTR}}$	1	TTL	I	weak pullup	Reset filter. Filtered input from the SCSI bus for a system reset. $\overline{\text{RSTFLTR}}$ differs from $\overline{\text{RESET}}$ by keeping the ARST and BRST drivers enabled.
SDB	20	TTL	O	N/A	A high-level logic signal that indicates a differential to single-ended data flow.
TEST	7	TTL	I	weak pulldown	Test. A high-level input that places the device in a test mode (see Table 1). It is grounded during normal operation.
$\overline{\text{TIMEOUT}}$	9	Analog	I/O	N/A	Time out. This signal connects to an external RC time constant for a time out during bus arbitration.
V <sub>CC</sub>	12, 18, 39, 45	N/A	N/A	N/A	5-V supply voltage
X1/CLK20	55	CMOS	I	none	20-MHz crystal oscillator or clock input
X2	56	Analog	O	none	20-MHz crystal oscillator feedback



# SN75LBC970A SCSI DIFFERENTIAL CONVERTER-CONTROL

SLLS215A – MAY 1995 – REVISED JULY 1996

## schematics of inputs and outputs

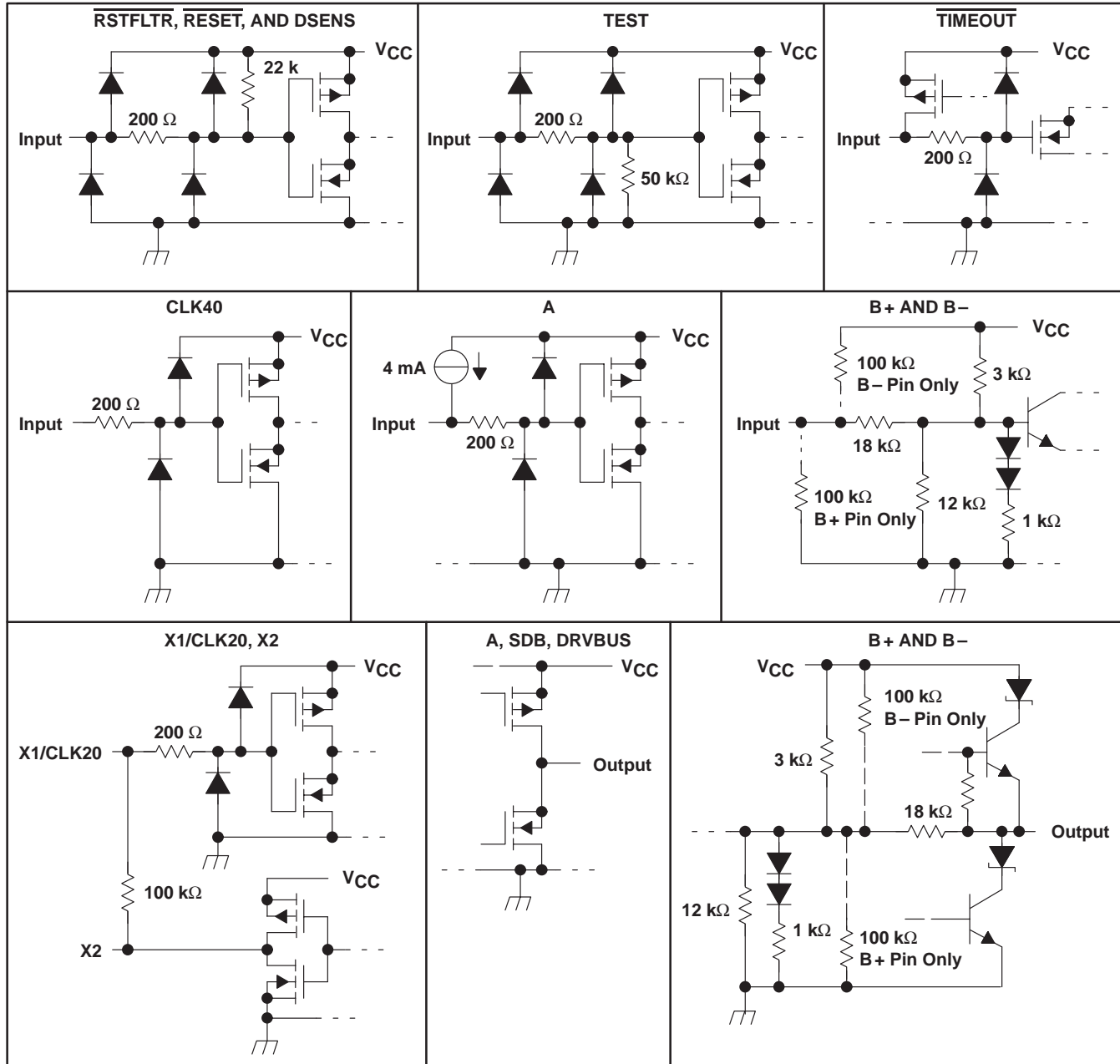

# SN75LBC970A

## SCSI DIFFERENTIAL CONVERTER-CONTROL

SLLS215A – MAY 1995 – REVISED JULY 1996

### absolute maximum ratings over operating free-air temperature range (unless otherwise noted)†

Supply voltage range, $V_{CC}$ (see Note 1)	–0.3 V to 7V
Differential bus voltage range (B side)	–15 V to 15 V
Signal-ended bus voltage range (A side and control)	–0.3 V to 7 V
Continuous total power dissipation	See Dissipation Rating Table
Electrostatic discharge: B side (see Note 2): Class 2, A:	2 kV
Class 2, B:	200 V
All terminals: Class 1, A:	500 V
Class 1, B:	200 V
Operating free-air temperature range, $T_A$	0°C to 70°C
Storage temperature range, $T_{stg}$	–65°C to 150°C
Lead temperature 1,6 mm (1/16 inch) from case for 10 seconds	260°C

† Stresses beyond those listed under “absolute maximum ratings” may cause permanent damage to the device. These are stress ratings only, and functional operation of the device at these or any other conditions beyond those indicated under “recommended operating conditions” is not implied. Exposure to absolute-maximum-rated conditions for extended periods may affect device reliability.

- NOTES: 1. All voltage values are with respect to the GND terminals.  
 2. This absolute maximum rating is tested in accordance with MIL-STD-883C, Method 3015.7.

**DISSIPATION RATING TABLE**

PACKAGE	$T_A \leq 25^\circ\text{C}$ POWER RATING	OPERATING FACTOR‡ ABOVE $T_A = 25^\circ\text{C}$	$T_A = 70^\circ\text{C}$ POWER RATING
DL	2500 mW	20 mW/°C	1600 mW

‡ This is the inverse of the traditional junction-to-case thermal resistance ( $R_{\theta JA}$ ).

### recommended operating conditions

		MIN	NOM	MAX	UNIT
Supply voltage, $V_{CC}$		4.75	5	5.25	V
High-level input voltage, $V_{IH}$	A side, DSENS, TEST, RESET, AND RSTFLTR	2			V
	CLK40 AND X1/CLK20	$0.7 V_{CC}$			
Low-level input voltage, $V_{IL}$	A side, DSENS, TEST, RESET, and RSTFLTR	0.8			V
	CLK40 AND X1/CLK20	$0.2 V_{CC}$			
Input voltage at any bus terminal (separately or common-mode), $V_I$	B side	12			V
		–7			
Output voltage at any bus terminal (separately or common-mode), $V_O$	B side	12			V
		–7			
High-level output current, $I_{OH}$	B side	–60			mA
	A side, DRVBUS, SDB, TIMEOUT	–16			
	X2	–4			
Low-level output current, $I_{OL}$	B side	60			mA
	A side, DRVBUS, and SDB	16			
	X2	4			
Clock frequency, $f_{CLK}$	CLK20	20			MHz
	CLK40	40			
Operating case temperature, $T_C$		0		125	°C
Operating free-air temperature, $T_A$		0		70	°C



# SN75LBC970A

## SCSI DIFFERENTIAL CONVERTER-CONTROL

SLLS215A – MAY 1995 – REVISED JULY 1996

electrical characteristics over recommended operating free-air temperature range (unless otherwise noted)

PARAMETER			TEST CONDITIONS	MIN	TYP†	MAX	UNIT
V <sub>OD(H)</sub>	Driver differential high-level output voltage	B side except BBSY, BRST, and BSEL	See Figure 1	1	1.8		V
V <sub>OD(L)</sub>	Driver differential low-level output voltage	B side		-1	-2.2		V
V <sub>OH</sub>	High-level output voltage	AACK-, AATN-, AC/D-, AI/O-, AMSG-, AREQ-	V <sub>ID</sub> = -200 mA, I <sub>OH</sub> = -16 mA	2.5	4.3		V
		DRVBUS, SDB	I <sub>OH</sub> = -16 mA	2.5	4.4		
		<u>TIMEOUT</u>	Test and RESET at 0.8 V, all others open, I <sub>OH</sub> = -16 mA	2.5	4.5		
		B side			3.4		
		X2	I <sub>OH</sub> = -4 mA	3.2			
V <sub>OL</sub>	Low-level output voltage	DRVBUS, SDB	I <sub>OL</sub> = 16 mA			0.8	V
		A side	V <sub>ID</sub> = 200 mV, I <sub>OL</sub> = 16 mA			0.8	
		B side			1.6		
		X2	I <sub>OL</sub> = 4 mA			0.8	
V <sub>IT+</sub>	Receiver positive-going input threshold voltage	B side	I <sub>OH</sub> = -16 mA, See Figure 2			0.2	V
		<u>TIMEOUT</u>			2.6		
V <sub>IT-</sub>	Receiver negative-going input threshold voltage	B side	I <sub>OL</sub> = 16 mA, See Figure 2	-0.2			V
		<u>TIMEOUT</u>		0.32 V <sub>CC</sub>	0.4 V <sub>CC</sub>		
V <sub>hys</sub>	Receiver input hysteresis (V <sub>IT+</sub> - V <sub>IT-</sub> )	B side			45		mV
		<u>TIMEOUT</u>		0.5			V
I <sub>I</sub>	Bus input current	B side	V <sub>I</sub> = 12 V, V <sub>CC</sub> = 5 V, all other inputs at 0 V		0.6	1	mA
			V <sub>I</sub> = 12 V, V <sub>CC</sub> = 0, all other inputs at 0 V		0.7	1	
			V <sub>I</sub> = -7 V, V <sub>CC</sub> = 5 V, all other inputs at 0 V		-0.5	-0.8	
			V <sub>I</sub> = -7 V, V <sub>CC</sub> = 0, all other inputs at 0 V		-0.4	-0.8	
I <sub>IH</sub>	High-level input current	A side	V <sub>IH</sub> = 2 V	-2.9	-6	-8	mA
		<u>DSSENS</u> , <u>RESET</u> , <u>RSTFLTR</u>			-60	-100	
		CLK40, X1/CLK20				±20	
		TEST				100	
		<u>TIMEOUT</u>	TEST at 2 V, A side and other control inputs at 0.8 V, B side open, V <sub>IH</sub> = 2 V			±1	μA
I <sub>IL</sub>	Low-level input current	A side	V <sub>IH</sub> = 0.8 V	-6	-8		mA
		<u>DSSENS</u> , <u>RESET</u> , <u>RSTFLTR</u>				-100	
		CLK40, TEST, X1/CLK20				±20	
		<u>TIMEOUT</u>	TEST at 0.8 V, A side and other control inputs at 0.8 V, B side open, V <sub>IH</sub> = 2 V			±1	μA
I <sub>OS</sub>	Short circuit output current	B side	V <sub>O</sub> = 5 V and 0 V			±250	mA

† All typical values are at V<sub>CC</sub> = 5 V, T<sub>A</sub> = 25 °C.



# SN75LBC970A SCSI DIFFERENTIAL CONVERTER-CONTROL

SLLS215A – MAY 1995 – REVISED JULY 1996

**electrical characteristics over recommended operating free-air temperature range (unless otherwise noted) (Continued)**

PARAMETER		TEST CONDITIONS	MIN	TYP†	MAX	UNIT
I <sub>CC</sub>	Supply current	Disabled		27	36	mA
		All A-side to B-side channels enabled		72	94	
		All B-side to A-side channels enabled		38	50	
C <sub>O</sub>	Bus output capacitance	B side to GND, V <sub>I</sub> = 0.6 sin(2π 10 <sup>6</sup> t) + 1.5 V		19	21	pF
C <sub>pd</sub>	Power dissipation capacitance (see Note 3)	B side to A side, one channel		100		pF
		A side to B side, one channel		450		pF

† All typical values are at V<sub>CC</sub> = 5 V, T<sub>A</sub> = 25 °C.

NOTE 3: C<sub>pd</sub> determines the no-load dynamic current consumption, I<sub>S</sub> = C<sub>pd</sub> × V<sub>CC</sub> × f + I<sub>CC</sub> (I<sub>CC</sub> depends upon the output states and load circuits and is not necessarily the same I<sub>CC</sub> as specified in the electrical tables).



# SN75LBC970A

## SCSI DIFFERENTIAL CONVERTER-CONTROL

SLLS215A – MAY 1995 – REVISED JULY 1996

switching characteristics over recommended operating free-air temperature range (unless otherwise noted)

PARAMETER	FROM (INPUT)	TO (OUTPUT)	TEST CONDITIONS	MIN	TYP†	MAX	UNIT
t <sub>d1</sub> , t <sub>d2</sub> Delay time, A to B, high- to low-level or low- to high-level output	AATN– AC/D– AI/O– AMSG–	BATN± BC/D± BI/O± BMSG±	See Figure 3	7.6		26.6	ns
	AACK– AREQ–	BACK± BREQ±	V <sub>CC</sub> = 5 V, T <sub>A</sub> = 25°C	8.5		25.3	
			V <sub>CC</sub> = 5 V, T <sub>A</sub> = 25°C	10		18	
			V <sub>CC</sub> = 5 V, T <sub>A</sub> = 70°C	12.5		20.5	
t <sub>sk(lim)</sub>	AACK– AREQ–	BACK± BREQ±	See Note 4			8	ns
t <sub>sk(p)</sub>	AACK– AREQ–	BACK± BREQ±	See Note 5			6	ns
t <sub>d3</sub> , t <sub>d4</sub> Delay time, B to A, high- to low-level or low- to high-level output	BATN± BC/D± BI/O± BMSG±	AATN– AC/D– AI/O– AMSG–	See Figure 4	21.5		36.2	ns
	BACK± BREQ±	AACK– AREQ–	V <sub>CC</sub> = 5 V, T <sub>A</sub> = 25°C	21.5		36.2	
			V <sub>CC</sub> = 5 V, T <sub>A</sub> = 25°C	23.6		32.6	
			V <sub>CC</sub> = 5 V, T <sub>A</sub> = 70°C	24.4		33.4	
t <sub>sk(lim)</sub>	BACK± BREQ±	AACK– AREQ–	See Note 4			9	ns
t <sub>sk(p)</sub>	BACK± BREQ±	AACK– AREQ–	See Note 5			6	ns
t <sub>PHL</sub>	TIMEOUT	DRVBUS	See Figure 5			200	ns
t <sub>PLH</sub>						200	ns
t <sub>dis</sub> Disable time	ABSY–	BBSY±	See Figure 6			200	ns
	ARST–	BRST±				200	
	ASEL–	BSEL±				200	
t <sub>en</sub> Enable time	ABSY–	BBSY±	See Figure 6			40	ns
	ARST–	BRST±				55	
	ASEL–	BSEL±				39	
t <sub>dis1</sub>	BRST±	ARST–	See Figure 7			93	ns
t <sub>dis2</sub>	BSEL±	ASEL–				55	ns
t <sub>dis3</sub>	BBSY±	ABSY–				60	ns
t <sub>en1</sub>	BRST±	ARST–				63	ns
t <sub>en2</sub>	BSEL±	ASEL–				45	ns
t <sub>en3</sub>	BBSY±	ABSY–				45	ns
t <sub>en4</sub>	BSEL±	ASEL–				92	ns

† All typical values are at V<sub>CC</sub> = 5 V, T<sub>A</sub> = 25 °C.

NOTES: 4. This parameter is applicable at one V<sub>CC</sub> and operating temperature within the recommended operating conditions and to any two devices.

5. Pulse skew is the difference between the high-to-low and low-to-high propagation delay times of any single channel.





PARAMETER MEASUREMENT INFORMATION

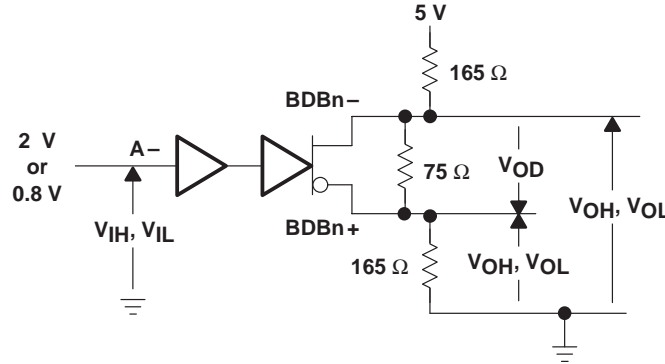

- NOTES: A. The input pulse is supplied by a generator having the following characteristics:  $t_r \leq 6 \text{ ns}$ ,  $t_f \leq 6 \text{ ns}$  PRR  $\leq 1 \text{ MHz}$ ,  $45\% < \text{duty cycle} < 50\%$ ,  $Z_O = 50 \Omega$ .  
 B. Resistance values are with a tolerance of 5%.  
 C. All input voltage levels are held to within 0.01 V.

Figure 1. Differential Driver  $V_{OD}$ ,  $V_{OH}$ , and  $V_{OL}$  Test Circuit

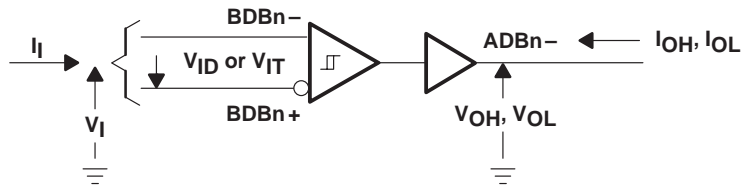
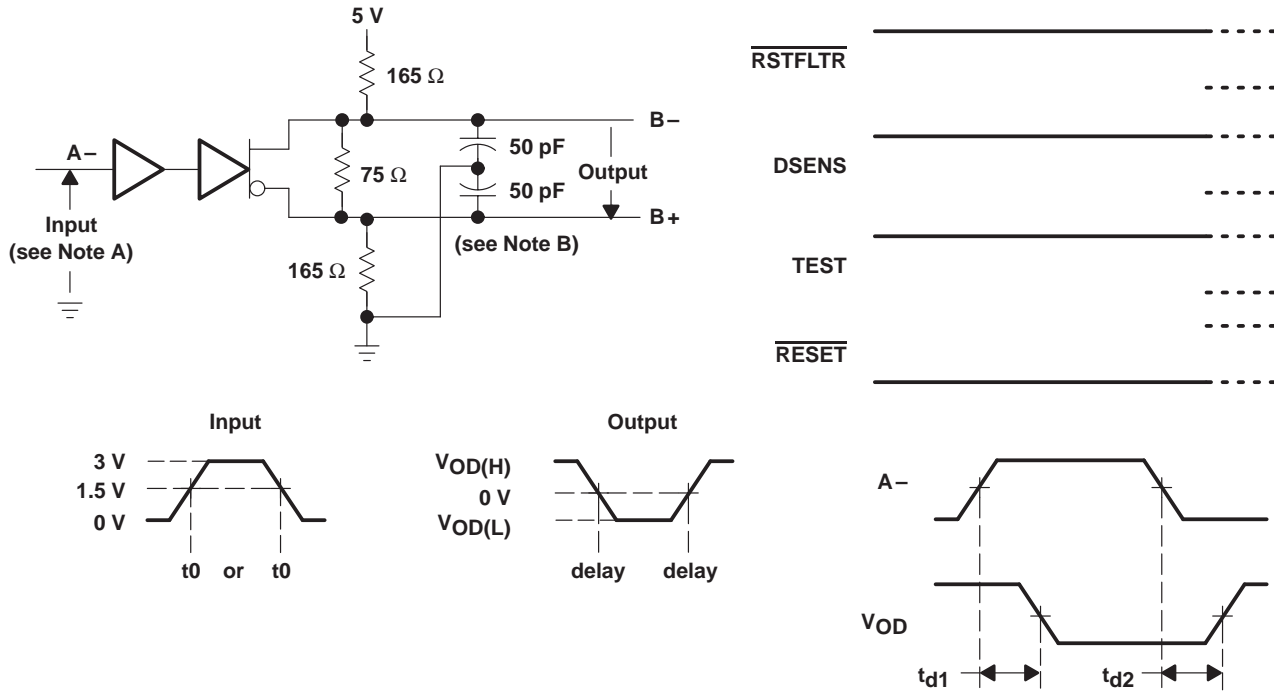

Figure 2. Single-Ended Driver  $V_{OD}$ ,  $V_{OH}$ , and  $V_{OL}$  Test Circuit

# SN75LBC970A SCSI DIFFERENTIAL CONVERTER-CONTROL

SLLS215A – MAY 1995 – REVISED JULY 1996

## PARAMETER MEASUREMENT INFORMATION



- NOTES: A. The input pulse is supplied by a generator having the following characteristics:  $t_r \leq 6$  ns,  $t_f \leq 6$  ns PRR  $\leq 1$  MHz,  $45\% < \text{duty cycle} < 50\%$ ,  $Z_0 = 50 \Omega$ .  
 B. Resistance values are with a tolerance of  $\pm 5\%$ .  
 C. All input voltage levels are held to within 0.01 V.

Figure 3. A-Side to B-Side Propagation Delay Time Test Circuit and Timing Definitions

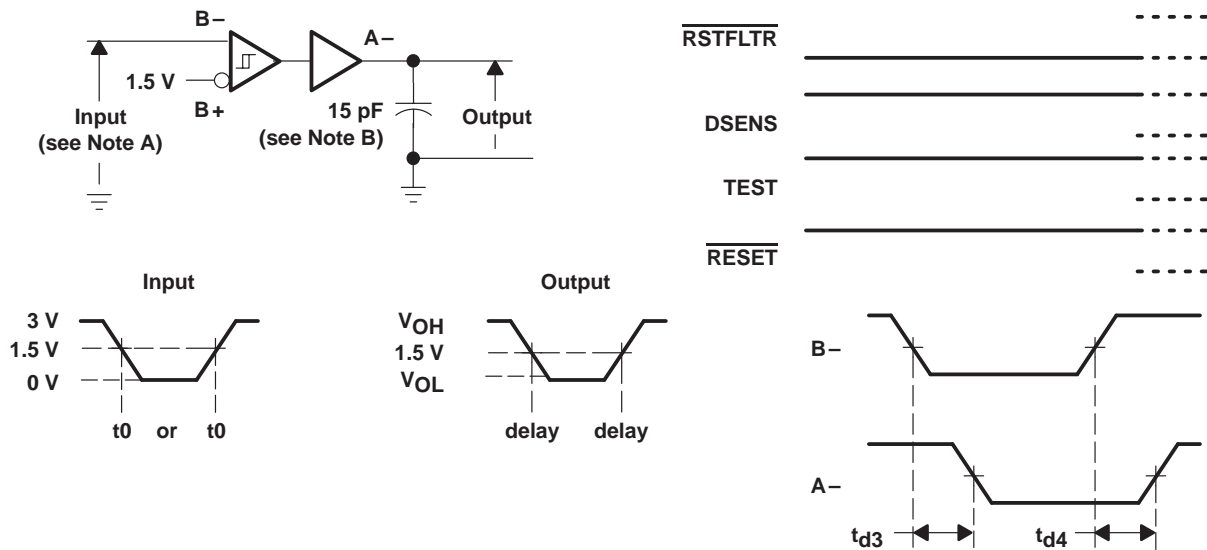

- NOTES: A. The input pulse is supplied by a generator having the following characteristics:  $t_r \leq 6$  ns,  $t_f \leq 6$  ns PRR  $\leq 1$  MHz,  $45\% < \text{duty cycle} < 50\%$ ,  $Z_0 = 50 \Omega$ .  
 B. Resistance values are with a tolerance of  $\pm 5\%$ .  
 C. All input voltage levels are held to within 0.01 V.

Figure 4. B-Side to A-Side Propagation Delay Time Test Circuit and Timing Definitions

PARAMETER MEASUREMENT INFORMATION

Table 1. Output Test Enabling (No Clock Input)

Signal	Bus		Control Input(s)						
	Input(s)	Output	TEST	RSTFLTR	RESET	BBSY-	BBSY+	ABSY-	DSENS
ATN, ACK, MSG, C/D, REQ, I/O	A	B	H	H	L				
ATN, ACK, MSG, C/D, REQ, I/O	B	A	H	L	L				
RST	A	B			L→H	H	L	H	H
RST	B	A			L→H	H	L	H	H
SEL, BSY	B	A	H	H	L				
SEL, BSY		B	L	H	L				H
TIMEOUT	N/A	H	L		L				
DRVBUS†	BBSY-/BBSY+, BSEL-/BSEL+, TIMEOUT	DRVBUS	H	L	L				
TIMEOUT	N/A	Z	H		L				

† For these conditions, DRVBUS = BSEL or BBSY and TIMEOUT together.

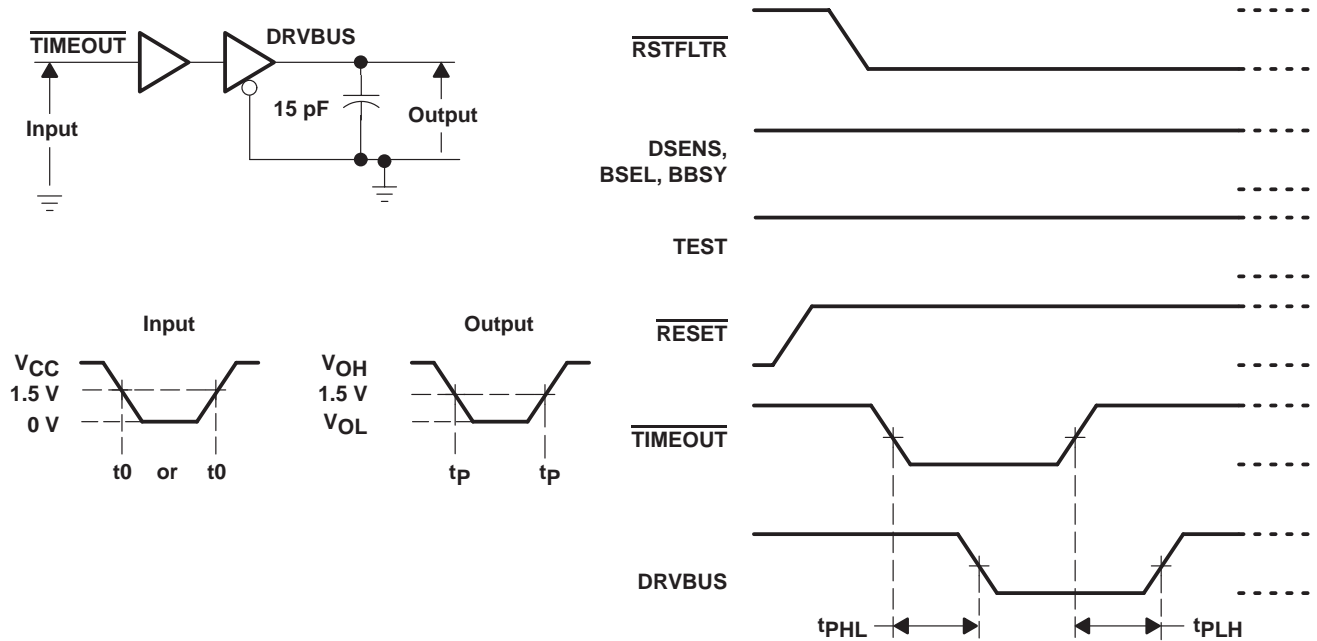
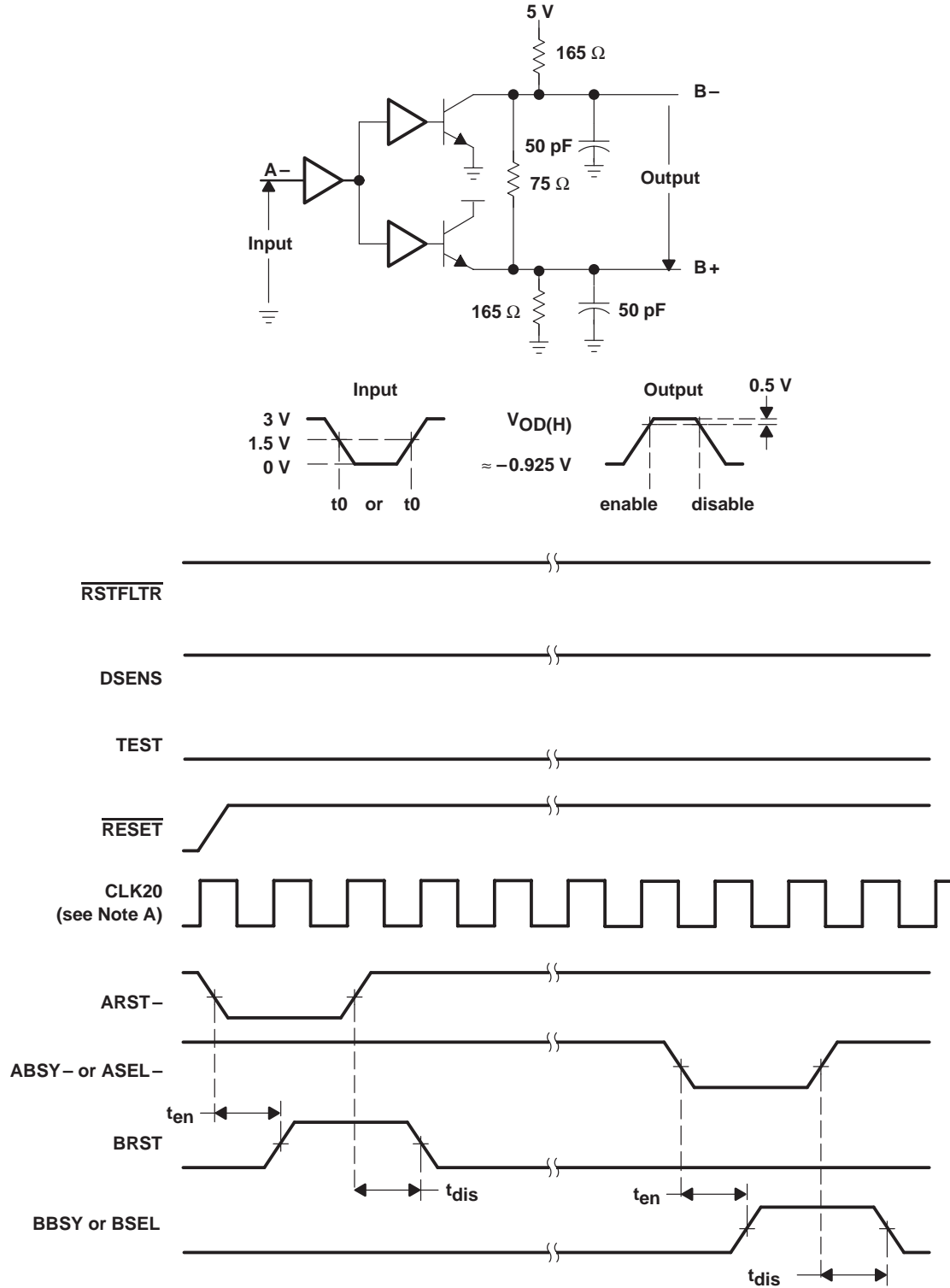

Figure 5. TIMEOUT to DRVBUS Delay Time Test Circuit and Timing Definitions

# SN75LBC970A SCSI DIFFERENTIAL CONVERTER-CONTROL

SLLS215A – MAY 1995 – REVISED JULY 1996

## PARAMETER MEASUREMENT INFORMATION



NOTE A: These are asynchronous events and do not necessarily align with clock edges.

Figure 6. A-Side to B-Side Enable and Disable Delay Time Test Circuit and Timing Definitions

PARAMETER MEASUREMENT INFORMATION

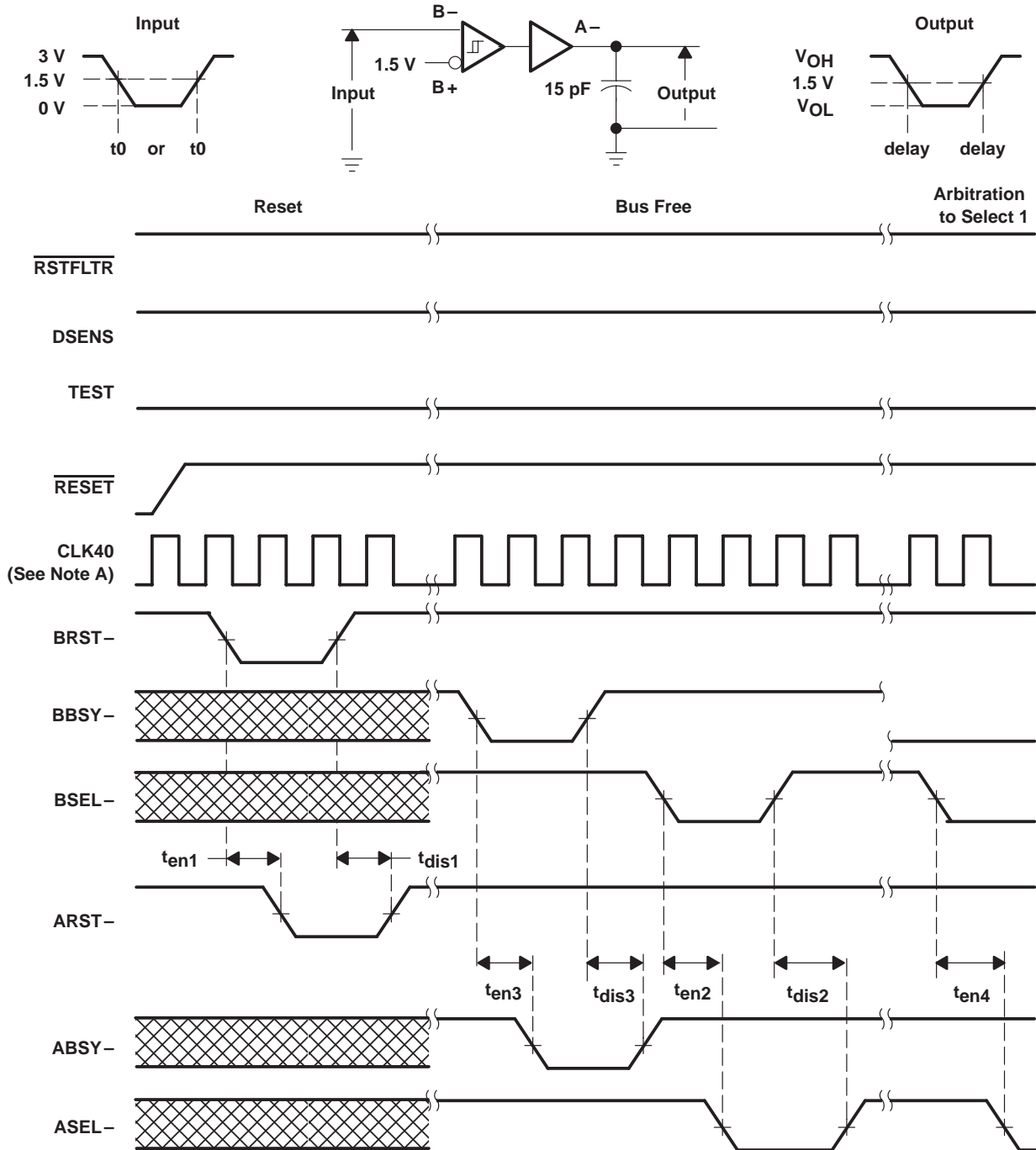

NOTE A: These are asynchronous events and do not necessarily align with clock edges.

Figure 7. B-Side to A-Side Enable and Disable Delay Time Test Circuit and Timing Definitions

# SN75LBC970A

## SCSI DIFFERENTIAL CONVERTER-CONTROL

SLLS215A – MAY 1995 – REVISED JULY 1996

---

### APPLICATION INFORMATION

To correctly set the direction of the SCSI bus signals, the SN75LBC970A must follow the activity on the bus. An asynchronous, 5-state controller watches the state of all the bus control signals, sets the direction of each control signal as needed, and generates the DRVBUS and SDB outputs to control one or two external SN75LBC971A SCSI differential converter-data devices. The controller never generates the data driven on a bus signal; it only enables the drivers. The clock input implements a 400-ns timer that is not part of the controller itself. Controller-state transitions occur immediately when all the transition conditions are met. Note that the frequency of the supplied clock, either 20 MHz or 40 MHz, must be correct in order to meet the SCSI specifications.

As shown in Figure 8, after reset, the controller begins in the bus free state. In case the controller was attached to an active differential bus, it waits for the SCSI bus free condition, defined as when BBSY and BSEL are deasserted for 400 ns. While waiting for the SCSI bus free condition, the state of BBSY and BSEL passes through to the A side. The A side bus device cannot take part in bus activity during this condition before the SCSI bus free condition. Once SCSI bus free is detected, the SCSI arbitration state is entered. Both ABSY and BBSY are enabled; thus when either signal asserts, both drivers turn on and both signals remain asserted until this state is left. Normally the SCSI arbitration state ends after the winner of arbitration asserts BSEL. This would cause the controller to go to the select 1 state. However, when BSEL is not asserted, a timeout would eventually be detected and cause a reset of the controller. In the select 1 state two latches are open, DSEL\_LATCH and RESEL\_LATCH. The first latch captures the state of BSEL so that following states can determine whether the arbitration winner was on the A side or B side.



POST OFFICE BOX 655303 • DALLAS, TEXAS 75265

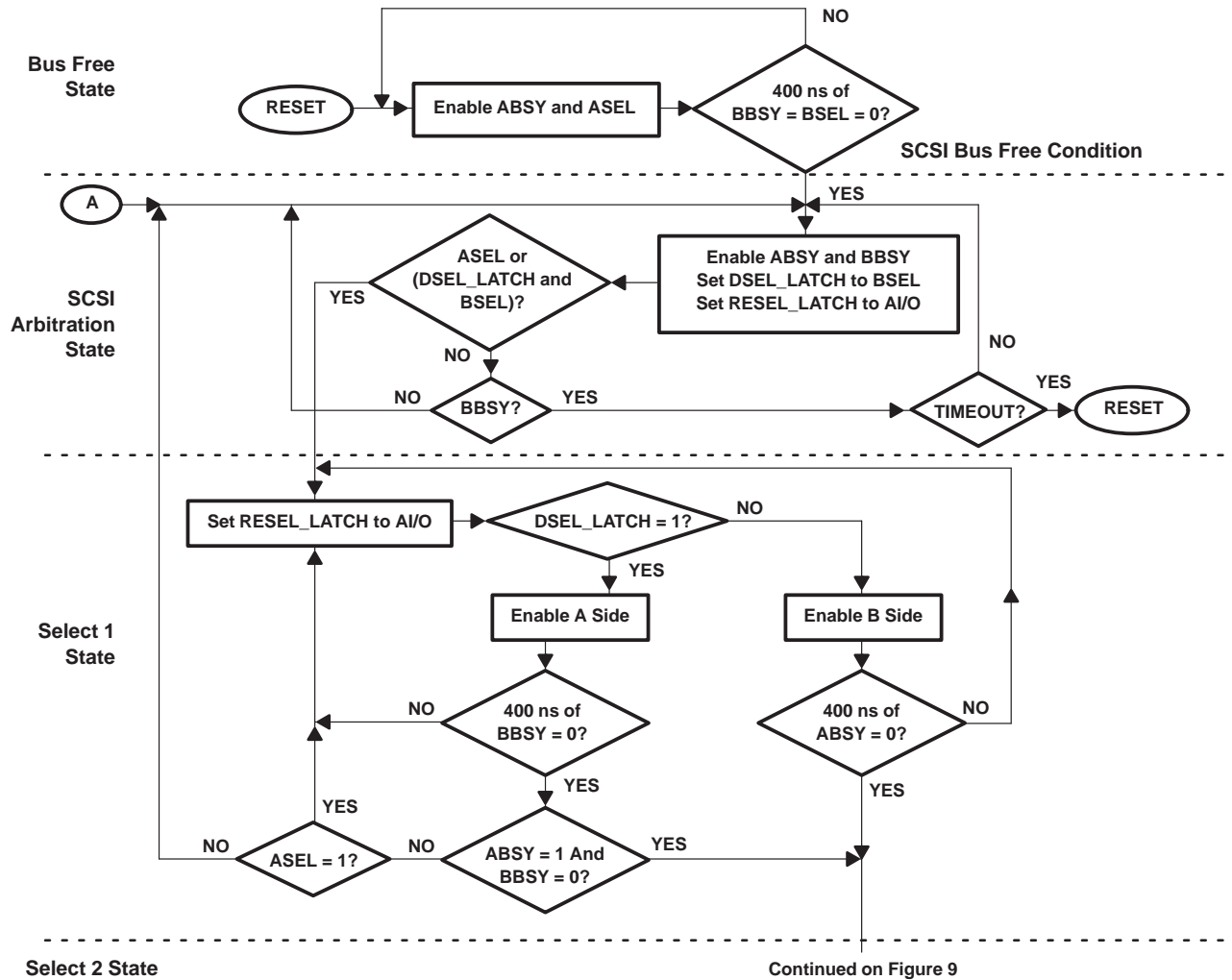

Figure 8. Bus Free, SCSI Arbitration, and Select 1 State Flow Chart

The second latch captures the state of A/I/O, this is true during a reselection phase but not during the selection phase. When the bus is in the selection or reselection phase, the controller enters the select 1 state. There are three possible flows depending on bus events. The first flow is that the SCSI controller on the A side won the arbitration and asserted ASEL. In this event DSEL\_LATCH would not be set. The controller passes all signals to the B side and waits for ABSY to deassert for 400 ns, indicating that the A side controller is selecting or reselecting a device on the B side. The object of the A side controller must be on the B side since only one device is allowed on the A side.

The second possible flow is that DSEL\_LATCH is set, indicating that the arbitration winner is on the B side, and the winner is selecting or reselecting the device on the A side. The controller passes all signals to the A side and waits for BBSY to deassert for 400 ns. When the A side controller responds by asserting ABSY, the controller detects ABSY asserted and BBSY deasserts and goes to the select 2 state.

# SN75LBC970A

## SCSI DIFFERENTIAL CONVERTER-CONTROL

SLLS215A – MAY 1995 – REVISED JULY 1996

---

### APPLICATION INFORMATION

The third possible flow is that a device on the B side won the arbitration and is selecting or reselecting another device on the B side. DSEL\_LATCH is set, and 400 ns of BBSY is asserted first by the object of the selection or reselection. Since ASEL is still asserted, the controller remains in the select 1 state throughout the selection or reselection. If the BBSY deassertion is missed by the timer, again the controller remains in the select 1 state. Once a the transfer state is entered, BBSY is asserted and BSEL is dropped. This again returns the controller to a select 1 state. At the end of the transfer both BBSY and BSEL are deasserted. After the timer limit is reached, the controller goes to the arbitration state for the next bus arbitration.

The controller enters the select 2 state (see Figure 9) during the selection or reselection phases when the initiator and terminator are on the opposite side of SDCC. In this state the RESEL\_LATCH is closed, capturing the value of the I/O. When RESEL\_LATCH is one, reselection is indicated. When RESEL\_LATCH equals zero, a selection is indicated. RESEL\_LATCH, along with the DSEL\_LATCH, now defines which side the initiator is on and therefore what direction to establish for all the bus signals. The target must be on the other side; if both target and initiator were on the B side, the select 2 state would never be entered.

When the RESEL\_LATCH is zero, indicating a selection, the connection is not made. When DSEL\_LATCH is one, the initiator is on the B side and the control lines it drives have their A side drivers enabled. These terminals are the initiator group of ACK and ATN along with SEL. The other terminals are driven by the target and have the B side drivers enabled. They are the target group of REQ, MSG, C/D, and I/O, along with BSY. When DSEL\_LATCH is zero the connection is reversed. Since transfer states are not started, DRVBUS is set to 1, indicating that the data transceiver chips should not take their direction control from SDB and should be actively negated. SDB is generated from I/O and is the bus signal that determines data transfer direction. In this case the it indicates the selection phase, the controller immediately transfers to the transfer state, where exactly the same actions are done.

When the RESEL\_LATCH is 1 indicating a reselection, there are one or more actions before information states can be entered. When the target reselects the initiator, the initiator responds by asserting BSY. Once the connection is made, the assertion of BSY must be changed over to the target, and the controller must reverse the BSY driver direction. It does this when SEL deasserts by transferring to the transfer state where the BSY direction is reversed. In the select 2 state all the control line directions are set as appropriate, except that DRVBUS is not yet asserted. In the transfer state DRVBUS is set as well.

The controller remains in the transfer state during all other SCSI states. When a bus free state is detected, it goes back to the arbitration state to wait for the next activity. Note that after BBSY and BSEL deassert, the controller continues to actively drive the control lines and the data lines through DRVBUS until 400 ns of continuous deassertion is detected. The drivers are turned off only when the state change occurs.

Figure 10 shows a typical system configuration. The timeout function used in the arbitration state is implemented with a resistor and capacitor connected to the  $\overline{\text{TIMEOUT}}$  terminal. During reset and whenever the timer is not in use, the terminal is driven to  $V_{CC}$ . The timer starts when the driver turns off, allowing the capacitor to charge and the  $\overline{\text{TIMEOUT}}$  terminal to drop to ground. When  $V_{IT-}$  is reached, the driver turns on, discharging the capacitor and returning  $\overline{\text{TIMEOUT}}$  to  $V_{CC}$ . A timeout event is declared after the driver turns back on and  $\overline{\text{TIMEOUT}}$  exceeds  $V_{IT+}$ .

RST can be asserted on either the A or B side, and is driven to the other side. The drive to the other side is controlled by a bidirectional latch. When one side asserts, the other side is asserted and a latch is set to that direction. When the first side deasserts, the driver turns off, but the direction is held until both sides are deasserted. Only then can the direction change.



POST OFFICE BOX 655303 • DALLAS, TEXAS 75265



APPLICATION INFORMATION

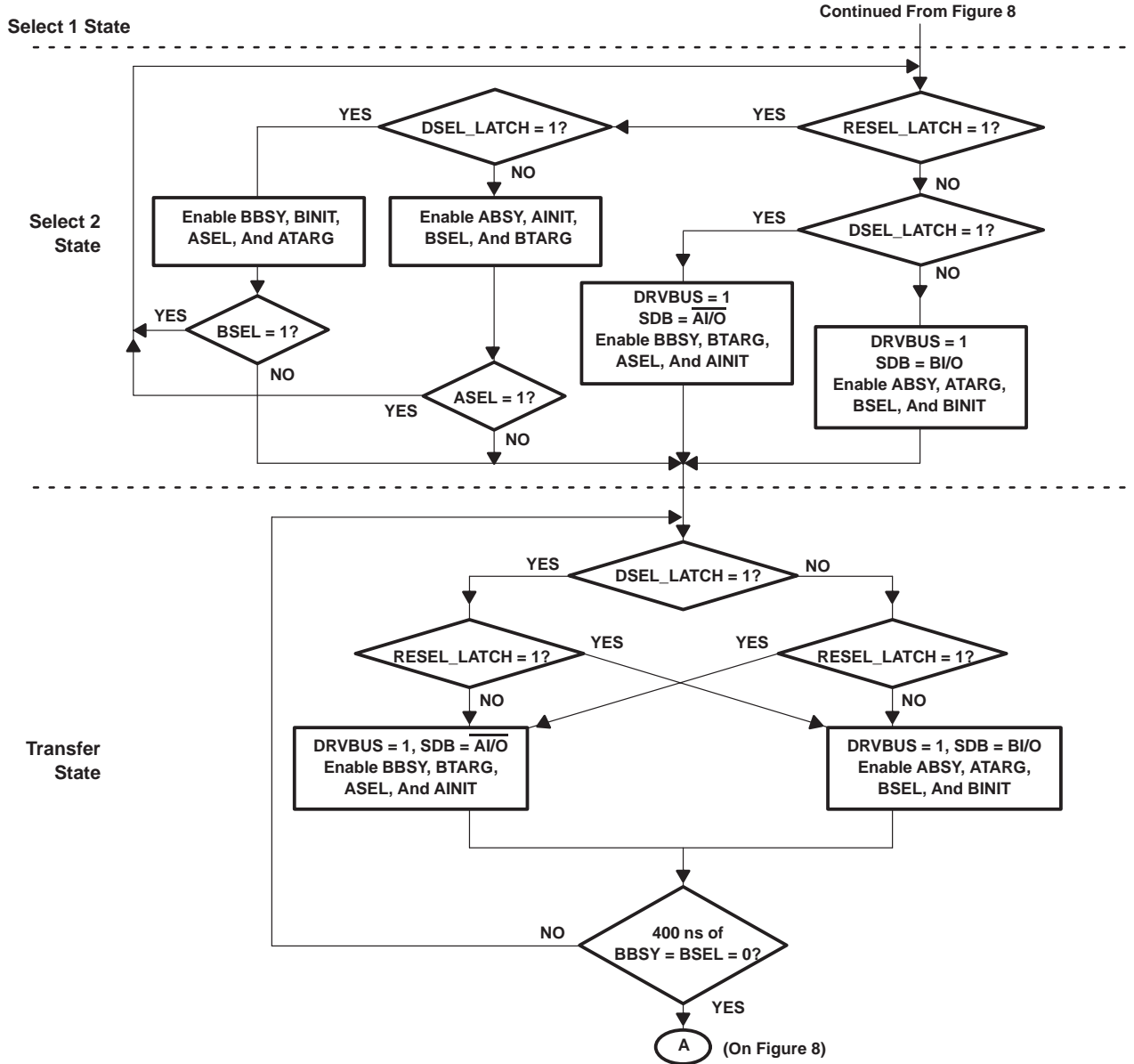

Figure 9. SCSI Select 1, Select 2, and Transfer State Flow Chart

# SN75LBC970A SCSI DIFFERENTIAL CONVERTER-CONTROL

SLLS215A – MAY 1995 – REVISED JULY 1996

## APPLICATION INFORMATION

The SCSI bus signal RST does not directly clear SDCC internal logic. Instead, the RSTFLTR terminal can be connected as ARST—so that a bus reset clears SDCC. RSTFLTR clears the internal controller but does not clear the RST bidirectional latch. By connecting these terminal externally through a RC filter as shown in Figure 8, noise pulses on the bus may be filtered as recommended by the SCSI-2 specification.

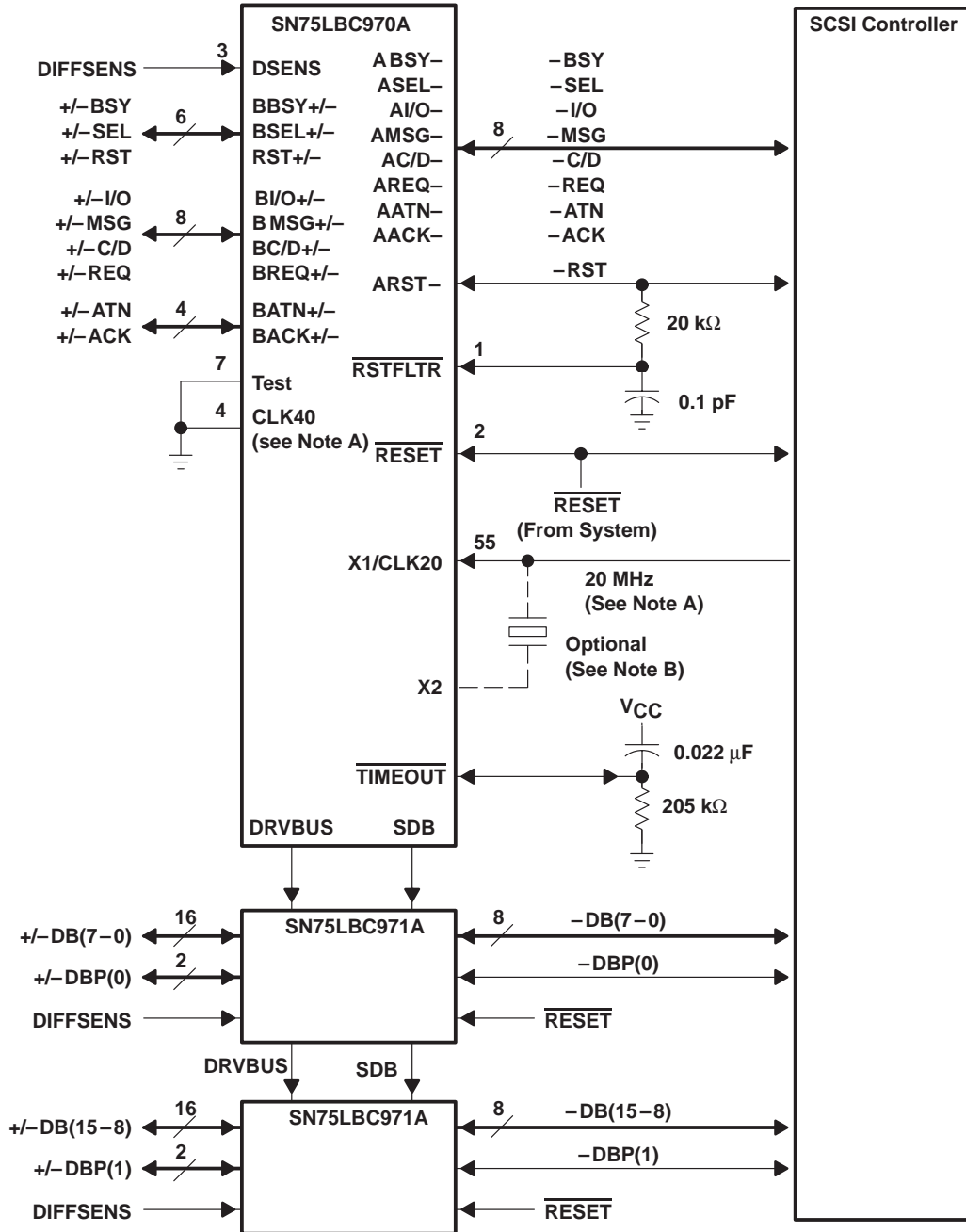

- NOTES: A. When using the 40 MHz clock input, X1 must be connected to VCC.  
 B. The oscillator cell of the SN75LBC970A is for a series-resonant crystal and needs approximately 10 pF (including fixture capacitance) from X1 and X2 to ground in order to function.

Figure 10. Typical Application of the SN75LBC970A and SN75LBC971A

# SN75LBC970A SCSI DIFFERENTIAL CONVERTER-CONTROL

SLLS215A – MAY 1995 – REVISED JULY 1996

## MECHANICAL INFORMATION

DL (R-PDSO-G\*\*)

PLASTIC SMALL-OUTLINE PACKAGE

48 PIN SHOWN

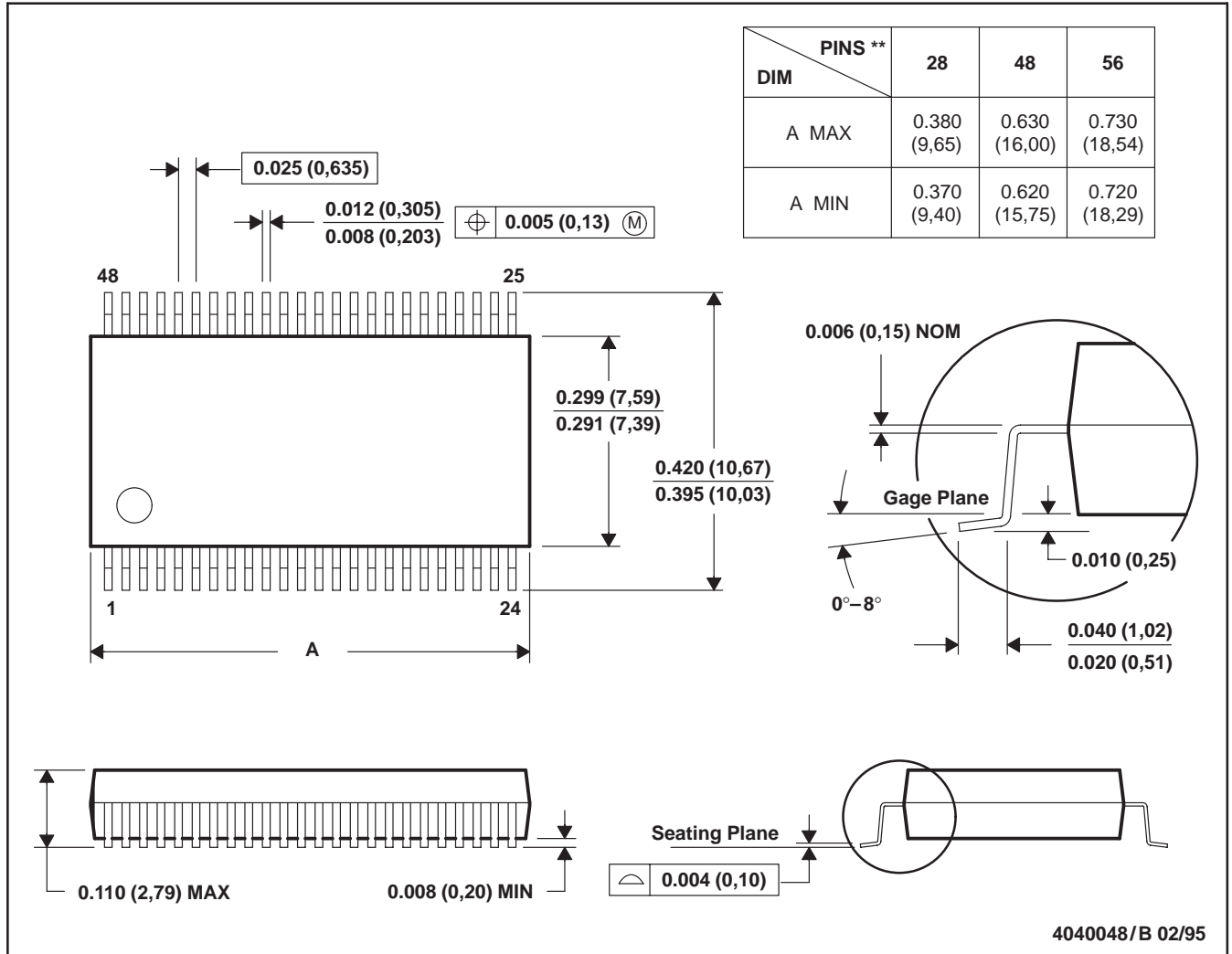

- NOTES: A. All linear dimensions are in inches (millimeters).  
 B. This drawing is subject to change without notice.  
 C. Body dimensions do not include mold flash or protrusion not to exceed 0.006 (0,15).

## **IMPORTANT NOTICE**

Texas Instruments and its subsidiaries (TI) reserve the right to make changes to their products or to discontinue any product or service without notice, and advise customers to obtain the latest version of relevant information to verify, before placing orders, that information being relied on is current and complete. All products are sold subject to the terms and conditions of sale supplied at the time of order acknowledgement, including those pertaining to warranty, patent infringement, and limitation of liability.

TI warrants performance of its semiconductor products to the specifications applicable at the time of sale in accordance with TI's standard warranty. Testing and other quality control techniques are utilized to the extent TI deems necessary to support this warranty. Specific testing of all parameters of each device is not necessarily performed, except those mandated by government requirements.

**CERTAIN APPLICATIONS USING SEMICONDUCTOR PRODUCTS MAY INVOLVE POTENTIAL RISKS OF DEATH, PERSONAL INJURY, OR SEVERE PROPERTY OR ENVIRONMENTAL DAMAGE ("CRITICAL APPLICATIONS"). TI SEMICONDUCTOR PRODUCTS ARE NOT DESIGNED, AUTHORIZED, OR WARRANTED TO BE SUITABLE FOR USE IN LIFE-SUPPORT DEVICES OR SYSTEMS OR OTHER CRITICAL APPLICATIONS. INCLUSION OF TI PRODUCTS IN SUCH APPLICATIONS IS UNDERSTOOD TO BE FULLY AT THE CUSTOMER'S RISK.**

In order to minimize risks associated with the customer's applications, adequate design and operating safeguards must be provided by the customer to minimize inherent or procedural hazards.

TI assumes no liability for applications assistance or customer product design. TI does not warrant or represent that any license, either express or implied, is granted under any patent right, copyright, mask work right, or other intellectual property right of TI covering or relating to any combination, machine, or process in which such semiconductor products or services might be or are used. TI's publication of information regarding any third party's products or services does not constitute TI's approval, warranty or endorsement thereof.