

TUSB2070 7-PORT HUB FOR THE UNIVERSAL SERIAL BUS

SLLS239B – NOVEMBER 1996 – REVISED AUGUST 1997

- **Universal Serial Bus (USB) Version 1.0 Compliant**
- **Integrated USB Transceivers**
- **Two Power Source Modes**
 - **Self-powered Mode Supporting Seven Downstream Ports**
 - **Bus-powered Mode Supporting Four Downstream Ports**
- **Power Switching and Overcurrent Reporting is Provided Per Port or Ganged**
- **Suspend Status Terminal Available for External Logic Power Down**
- **All Downstream Ports Support Full-Speed and Low-Speed Operations**
- **Supports Suspend and Resume Operations**
- **Available in 48-Pin TQFP[†] Package**
- **3.3-V Operation**

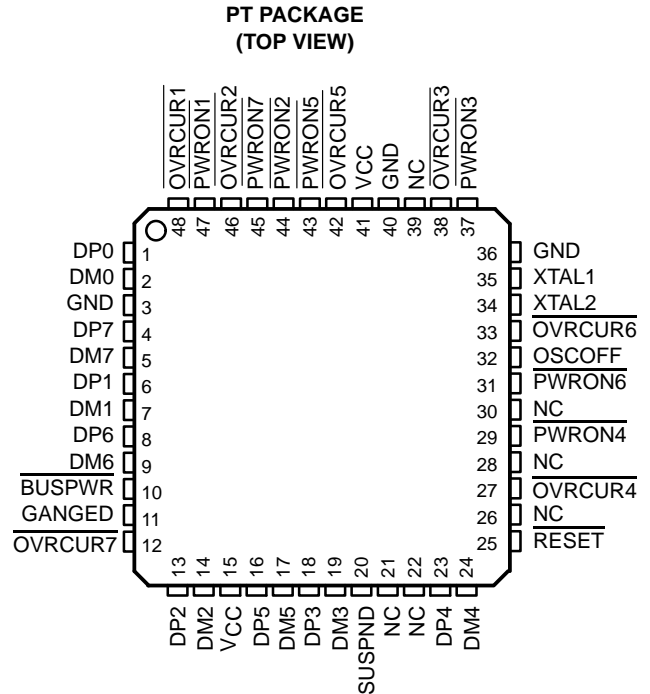

description

The TUSB2070 hub is a CMOS device that provides up to seven downstream ports in conformance with the USB specification, version 1.0. It supports two power source modes: bus-powered and self-powered. The hub and downstream ports share the same power source. Per the USB Specification, in the bus-powered mode, only four downstream ports (1-4) are operational, and if all seven ports are desired, the hub must be powered in the self-powered mode. The TUSB2070 hub powers down to 20 nA during the suspend operation by powering down the internal oscillator.

The TUSB2070 hub supports power switching to the downstream ports either individually or ganged. An external device or devices are required to switch power and to detect overcurrent conditions. The TUSB2070 provides outputs to control power switching and inputs to monitor any overcurrent conditions. In the ganged operation, all PWRON signals transition simultaneously and any OVRRCUR input may be used.

The hub requires a 48-MHz clock signal to sample data from the upstream port and generate a synchronized 12-MHz USB clock signal. The hub supports the flexibility to use either a 48-MHz oscillator or a crystal tuned to 48-MHz. If an oscillator is used, connect its output to the XTAL1 terminal and leave the XTAL2 terminal open. An oscillator with TTL output may be used if the output does not exceed 3.6 V. For a crystal implementation, use the XTAL1 terminal as the input and the XTAL2 terminal as the feedback path to the crystal. Because the crystal is required to resonate at 48-MHz, a tuning circuit as shown in Figure 6 may be required.

USB-compliant transceivers are provided for the upstream port and all downstream ports. Every downstream port supports both full- and low-speed connection by automatically setting the slew rate according to the speed of the device attached to the port.

[†] JEDEC descriptor S-PQFP-G for thin quad flatpack (TQFP)



Please be aware that an important notice concerning availability, standard warranty, and use in critical applications of Texas Instruments semiconductor products and disclaimers thereto appears at the end of this data sheet.

PRODUCTION DATA information is current as of publication date. Products conform to specifications per the terms of Texas Instruments standard warranty. Production processing does not necessarily include testing of all parameters.

**TEXAS
INSTRUMENTS**

POST OFFICE BOX 655303 • DALLAS, TEXAS 75265

Copyright © 1997, Texas Instruments Incorporated

Terminal Functions

TERMINAL NAME	NO.	I/O	DESCRIPTION
$\overline{\text{BUSPWR}}$	10	I	Power source indicator. $\overline{\text{BUSPWR}}$ is an active low input that indicates whether the ports and the hub derive power from the bus or are self-powered by the local supply. This standard TTL input must not change dynamically during operation.
DM0	2	I/O	Root port USB differential data minus. DM0 paired with DP0 constitutes the upstream USB port.
DM1 – DM7	7, 14, 19, 24, 17, 9, 5	I/O	USB differential data minus. DM1 – DM7 paired with DP1 – DP7 support up to seven downstream USB ports.
DP0	1	I/O	Root port USB differential data plus. DP0 paired with DM0 constitutes the upstream USB port.
DP1 – DP7	6, 13, 18, 23, 16, 8, 4	I/O	USB differential data minus. DP1–DP7 paired with DM1 – DM7 support up to seven downstream USB ports.
GANGED	11	I	Power switching/overcurrent detection mode. GANGED selects between gang or per port switching and overcurrent detection for downstream ports. This standard TTL input must not change dynamically during operation.
GND	3, 36, 40		Ground. GND terminals must be tied to ground for proper operation.
OSCOFF	32	I	Oscillator off. OSCOFF disables the internal oscillator for quiescent current draw (ICCQ) testing. OSCOFF must be tied low for proper operation.
$\overline{\text{OVRCUR1}} - \overline{\text{OVRCUR7}}$	48, 46, 38, 27, 42, 33, 12	I	Overcurrent indicators. $\overline{\text{OVRCUR1}} - \overline{\text{OVRCUR7}}$ are active low, standard TTL inputs. One overcurrent indicator is available for each of the seven downstream ports. In GANGED mode, one implementation is to tie these inputs together. Alternatively, one $\overline{\text{OVRCUR}}$ input pin may be used with the remaining $\overline{\text{OVRCUR}}$ pins tied to V_{CC} .
$\overline{\text{PWRON1}} - \overline{\text{PWRON7}}$	47, 44, 37, 29, 43, 31, 45	O	Power-on/off control signals. $\overline{\text{PWRON1}} - \overline{\text{PWRON7}}$ are active low, open-drain outputs. One power on/off control switch is used for each of the seven downstream ports. In GANGED mode, all outputs are switched together.
$\overline{\text{RESET}}$	25	I	Reset. $\overline{\text{RESET}}$ is an active low TTL input with hysteresis and must be asserted at power up. When $\overline{\text{RESET}}$ is asserted, it initializes all logic.
SUSPND	20	O	Suspend status. SUSPND is an active high output that is available for external logic power down operations. During the SUSPEND mode, SUSPND is high. SUSPND is low for normal operation.
V_{CC}	15, 41		3.3-V supply voltage
XTAL1	35	I	Crystal 1. XTAL1 is a 48-MHz crystal input with 50% duty cycle. Operation at 48-MHz is four times the USB full-speed bit rate of 12-Mbps.
XTAL2	34	O	Crystal 2. XTAL2 is a 48-MHz crystal output. Operation at 48-MHz is four times the USB full-speed bit rate of 12-Mbps. This terminal is left open when using an oscillator.

absolute maximum ratings over operating free-air temperature range (unless otherwise noted)†

Supply voltage range, V_{CC} (see Note 1)	–0.5 V to 3.8 V
Input voltage range, V_I	–0.5 V to $V_{CC} + 0.5$ V
Output voltage range, V_O	–0.5 V to $V_{CC} + 0.5$ V
Input clamp current, I_{IK} , ($V_I < 0$ V or $V_I > V_{CC}$)	±20 mA
Output clamp current, I_{OK} , ($V_O < 0$ V or $V_O > V_{CC}$)	±20 mA
Storage temperature range, T_{stg}	–65°C to 150°C

† Stresses beyond those listed under “absolute maximum ratings” may cause permanent damage to the device. These are stress ratings only, and functional operation of the device at these or any other conditions beyond those indicated under “recommended operating conditions” is not implied. Exposure to absolute-maximum-rated conditions for extended periods may affect device reliability.

NOTE 1: All voltage levels are with respect to GND.

TUSB2070

7-PORT HUB FOR THE UNIVERSAL SERIAL BUS

SLLS239B – NOVEMBER 1996 – REVISED AUGUST 1997

recommended operating conditions

	MIN	NOM	MAX	UNIT
Supply voltage, V_{CC}	3	3.3	3.6	V
Input voltage, TTL/LVCMOS \ddagger , V_I	0		V_{CC}	V
Output voltage, TTL/LVCMOS \S , V_O	0		V_{CC}	V
High-level input voltage, signal-ended receiver, $V_{IH(REC)}$	2		V_{CC}	V
Low-level input voltage, signal-ended receiver, $V_{IL(REC)}$			0.8	V
High-level input voltage, TTL/LVCMOS \ddagger , $V_{IH(TTL)}$	2		V_{CC}	V
Low-level input voltage, TTL/LVCMOS \ddagger , $V_{IL(TTL)}$			0.8	V
Operating free-air temperature, T_A	0		70	°C
External series, differential driver resistor, $R_{(DRV)}$	22 (-5%)		22 (+5%)	Ω
Operating (DC differential driver) high speed mode, $f_{(OPRH)}$			12	Mb/s
Operating (DC differential driver) low speed mode, $f_{(OPRL)}$			1.5	Mb/s
Common mode, input range, differential receiver, $V_{(ICR)}$	0.8		2.5	V
Input transition times (t_r and t_f), TTL/LVCMOS \ddagger	0		6	ns

\ddagger Applies for input and bidirectional buffers

\S Applies for output and bidirectional buffers

\uparrow V_{CC} must be at specified operating voltage for 5-V-tolerant operation.

Output must be in a high-impedance state for 5-V-tolerant operation.

|| These junction temperatures reflect simulated conditions. Absolute maximum junction temperature is 150° C. The customer is responsible for verifying junction temperature.

electrical characteristics over recommended ranges of operating free-air temperature and supply voltage (unless otherwise noted)

PARAMETER		TEST CONDITIONS	MIN	MAX	UNIT	
V_{OH}	High-level output voltage	USB data lines	$R_{(DRV)} = 15\text{ k}\Omega$, to GND	2.8	3.6	V
			$I_{OH} = -12\text{ mA}$ (without $R_{(DRV)}$)	$V_{CC} - 0.5$		
V_{OL}	Low-level output voltage	TTL/LVCMOS	$I_{OL} = 4\text{ mA}$		0.5	V
		USB data lines	$R_{(DRV)} = 1.5\text{ k}\Omega$ to 3.6 V		0.3	
			$I_{OL} = 12\text{ mA}$ (without $R_{(DRV)}$)		0.5	
V_{IT+}	Positive input threshold voltage	TTL/LVCMOS			2	V
		Single-ended	$0.8\text{ V} \leq V_{ICR} \leq 2.5\text{ V}$		1.8	V
V_{IT-}	Negative-input threshold voltage	TTL/LVCMOS		0.8		V
		Single-ended	$0.8\text{ V} \leq V_{ICR} \leq 2.5\text{ V}$	1		V
V_{hys}	Input hysteresis \ddagger ($V_{T+} - V_{T-}$)	TTL/LVCMOS		0.25	0.7	V
		Single-ended	$0.8\text{ V} \leq V_{ICR} \leq 2.5\text{ V}$	300	500	mV
I_{OZ}	High-impedance output current	TTL/LVCMOS	$V = V_{CC}$ or GND \ddagger		± 10	μA
		USB data lines	$0\text{ V} \leq V_O \leq V_{CC}$		± 10	μA
I_{IL}	Low-level input current	TTL/LVCMOS	$V_I = \text{GND}$		-1	μA
I_{IH}	High-level input current	TTL/LVCMOS	$V_I = V_{CC}$		1	μA
$Z_{O(DRV)}$	Driver output impedance	USB data lines	Static V_{OH} or V_{OL}	7.1	19.9	Ω
V_{ID}	Differential input voltage	USB data lines	$0.8\text{ V} \leq V_{ICR} \leq 2.5\text{ V}$	0.2		V
I_{CC}	Input supply current		Normal operation		100	mA
			Suspend mode		1	μA

\ddagger Applies for input buffers with hysteresis

\ddagger Applies for open drain buffers



differential driver switching characteristics over recommended ranges of operating free-air temperature and supply voltage, $C_L = 50$ pF unless otherwise noted (see Figures 1 and 2)

full speed mode

PARAMETER		TEST CONDITIONS	MIN	MAX	UNIT
t_r	Transition rise time for DP or DM	See Figure 1 and Figure 2	4	20	ns
t_f	Transition fall time for DP or DM	See Figure 1 and Figure 2	4	20	ns
$t_{(RFM)}$	Rise/fall time matching	$(t_r/t_f) \times 100$	90	110	%
$V_{O(CRS)}$	Signal crossover output voltage		1.3	2	V

low speed mode

PARAMETER		TEST CONDITIONS	MIN	MAX	UNIT
t_r	Transition rise time for DP to DM	$C_L = 50$ pF to 350 pF, See Figure 1 and Figure 2	75	300	ns
t_f	Transition fall time for DP to DM	$C_L = 50$ pF to 350 pF, See Figure 1 and Figure 2	75	300	ns
$t_{(RFM)}$	Rise/fall time matching	$(t_r/t_f) \times 100$	80	120	%
$V_{O(CRS)}$	Signal crossover output voltage	$C_L = 50$ pF to 350 pF	1.3	2.0	V

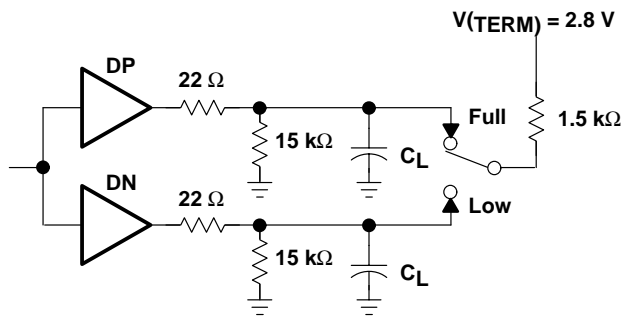

Figure 1. Differential Driver Switching Load

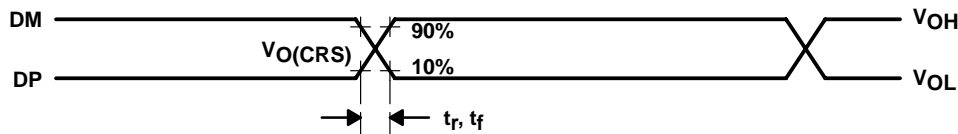

Figure 2. Differential Driver Timing Waveforms

TUSB2070 7-PORT HUB FOR THE UNIVERSAL SERIAL BUS

SLLS239B – NOVEMBER 1996 – REVISED AUGUST 1997

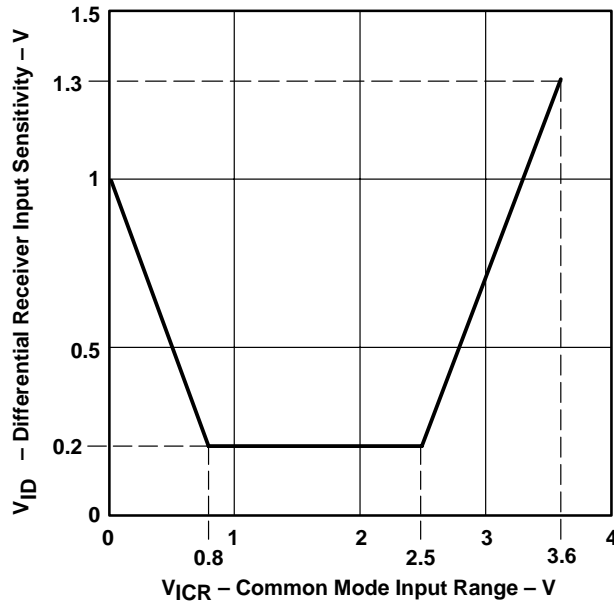

Figure 3. Differential Receiver Input Sensitivity vs. Common Mode Input Range

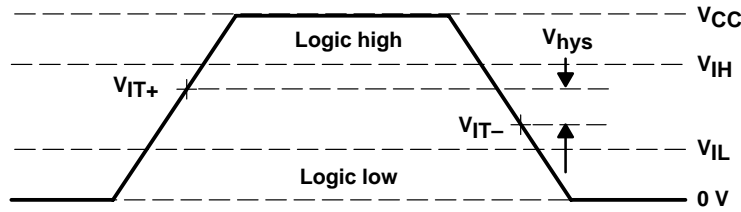

Figure 4. Single-Ended Receiver Input Signal Parameter Definitions

APPLICATION INFORMATION

USB design notes

The USB is a serial bus interface providing 5-V power and data to peripheral functions (printers, monitors, joysticks, mice, keyboards and hubs). USB specifies three power modes for functions: low-power, high-power, and self-powered. Low-power mode functions draw a maximum current of 100 mA from the USB 5-V line. High-power mode functions may draw a maximum current of 500 mA from the USB 5-V line and may only be connected to self-powered hubs. Self-powered mode functions contain their own power supply but are permitted a maximum current draw of 100 mA from the USB 5-V line for communication purposes. (A typical application of the TUSB2070 universal serial bus hub is shown in Figure 5).

All USB data lines must be terminated with 22Ω resistors. All downstream port data lines (DM1 – DM7, DP1 – DP7) must be pulled down with 15 kΩ resistors. DP0 must be pulled up with a 1.5 kΩ resistor (see Figure 1).

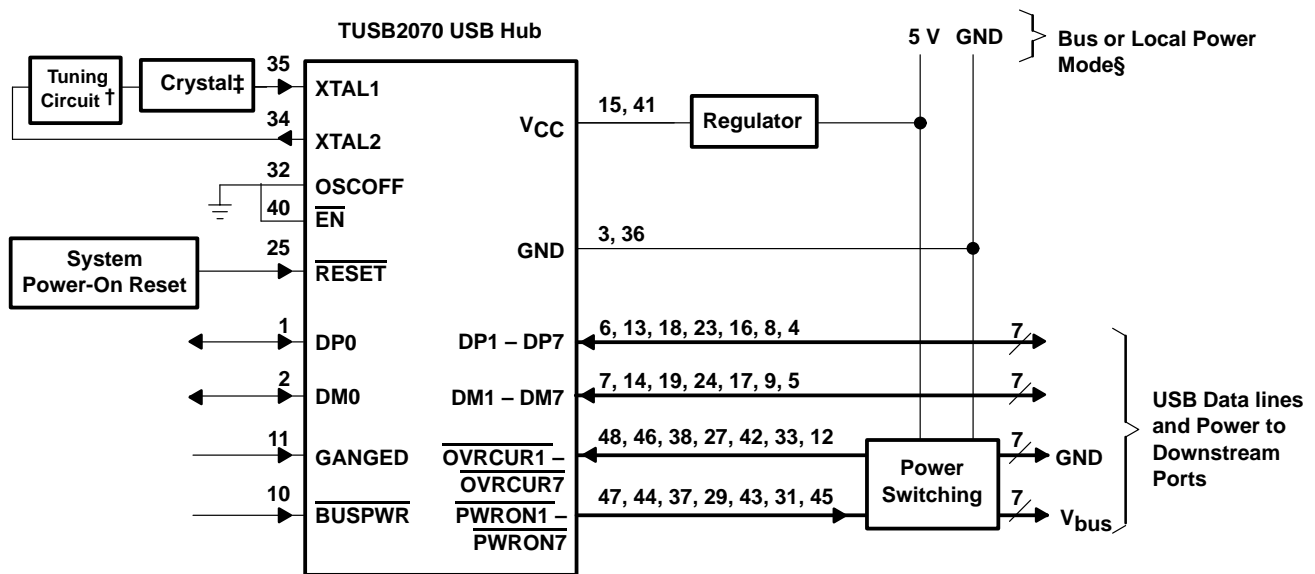

† Values for timing components are subject to change when using different crystals and PCBs.

‡ The crystal in this application is a 48-MHz US Crystal, P/N HC-18/U 48MHZ.

§ $\overline{\text{BUSPWR}}$ input should be set according to the system power source. If self-powered, the local ground is tied to the USB ground.

Figure 5. Typical Application of the TUSB2070 USB Hub

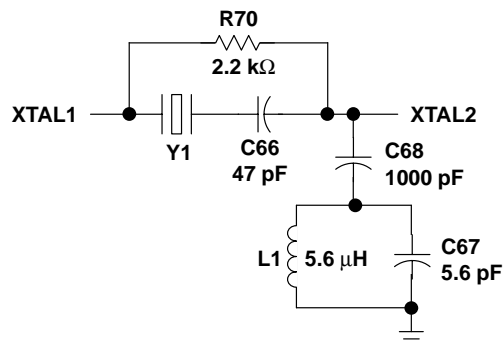

NOTES: A. When tuning the crystal (Y1) for different board implementations, the capacitor (C67) is subject to change. Other components should remain the same.

Figure 6. Tuning Circuit

TUSB2070 7-PORT HUB FOR THE UNIVERSAL SERIAL BUS

SLLS239B – NOVEMBER 1996 – REVISED AUGUST 1997

APPLICATION INFORMATION

A major advantage of USB is the ability to connect 127 functions configured in up to 6 logical layers (tiers) to a single personal computer (See Figure 7).

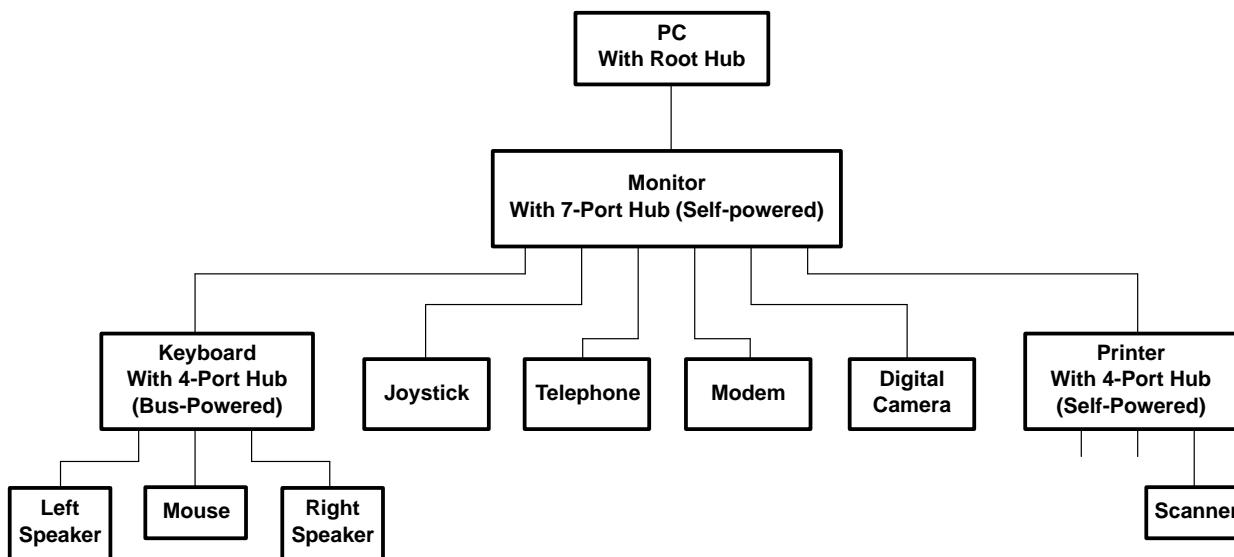

Figure 7. USB Tiered Configuration Example

Another advantage of USB is that all peripherals are connected using a standardized 4-wire cable which provides both communication and power distribution. The three power configurations are Bus-Powered, Self-Power and High-Power mode. For all three configurations, 100 mA is the maximum current that may be drawn from the USB 5 V line during power-up. For Bus-Power mode, a hub can draw a maximum of 500 mA from the 5 V line of the USB cable. A Bus-Powered hub must always be connected downstream to a Self-Powered hub unless it is the only hub connected to the PC and there are no High-Powered functions connected downstream. In the Self-Power mode, the hub is connected to its own power supply and can supply up to 500 mA to each downstream port. High-Powered functions may draw a maximum of 500 mA and may only be connected downstream to Self-Powered hubs.

Both Bus-Powered and Self-Powered hubs require over-current protection for all downstream ports. The two types of protection are individual port management (individual port basis) or ganged port management (multiple port basis). Individual port management requires power management devices for each individual downstream port, but adds robustness to your USB system because, in the event of an over-current condition, the USB Host will only power-down the port that has the condition. The ganged configuration uses fewer power management devices and thus has lower system costs, but in the event of an over-current condition on any of the downstream ports, all the ganged ports will be disabled by the USB Host.

Using a combination of the $\overline{\text{BUSPWR}}$ and GANGED inputs, the TUSB2140 supports four modes of power management: Bus-Powered hub with either individual port power management or ganged port power management and the Self-Powered hub with either individual port power management or ganged port power management. Texas Instruments supplies the complete hub solution because we offer this TUSB2070, the TUSB2040 (4-port) and the TUSB2140 (4-port with I²C) hubs along with the power management chips needed to implement a fully USB Specification 1.0 compliant system. See Figure 8, 9 and 10 for example configurations.

APPLICATION INFORMATION

bus-powered hub, ganged port power management

A bus-powered TUSB2070 supports up to four downstream ports (operation shown in Figure 8) and is capable of supplying 100 mA of current for low-power device class functions to each downstream port. DP5 – DP7 and DM5 – DM7 are disabled in the bus-powered mode. Bus-powered hubs must implement power switching. Ganged power management (see Figure 8) utilizes the TPS2014 power switch device, and provides over current protection for downstream ports. Individual SN75240 transient suppressors reduce in-rush current and voltage spikes. The TPS7133 low-dropout voltage regulator provides a Power Good (PG) signal for reset at power up. OVRCUR1 – OVRCUR4 inputs may be tied together for ganged mode operation. OVRCUR5 – OVRCUR7 are not used and should be tied to the same logic level.

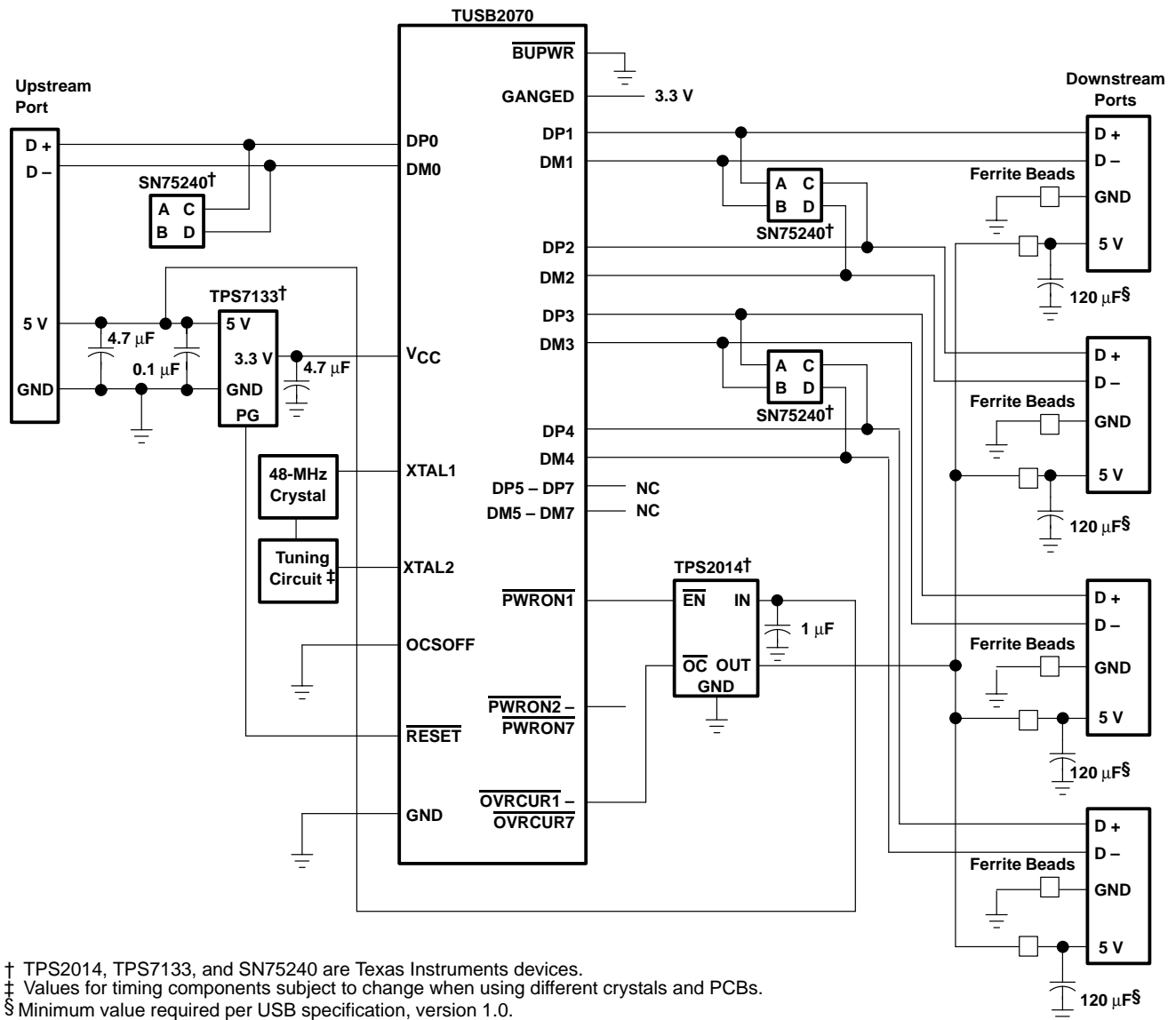

† TPS2014, TPS7133, and SN75240 are Texas Instruments devices.
 ‡ Values for timing components subject to change when using different crystals and PCBs.
 § Minimum value required per USB specification, version 1.0.

Figure 8. TUSB2070 Bus-Powered Hub, Ganged Port Power Management Application

TUSB2070 7-PORT HUB FOR THE UNIVERSAL SERIAL BUS

SLLS239B – NOVEMBER 1996 – REVISED AUGUST 1997

APPLICATION INFORMATION

self-powered hub, ganged port power management

A self-powered TUSB2070 supports up to seven downstream ports (Ports 3–5 are not shown in Figure 9 but should be connected similarly to ports shown). One TPS2015 provides power switching and overcurrent protection for two ports. Although this is a more economical solution, a fault on one downstream port will cause power to be removed from all downstream ports.

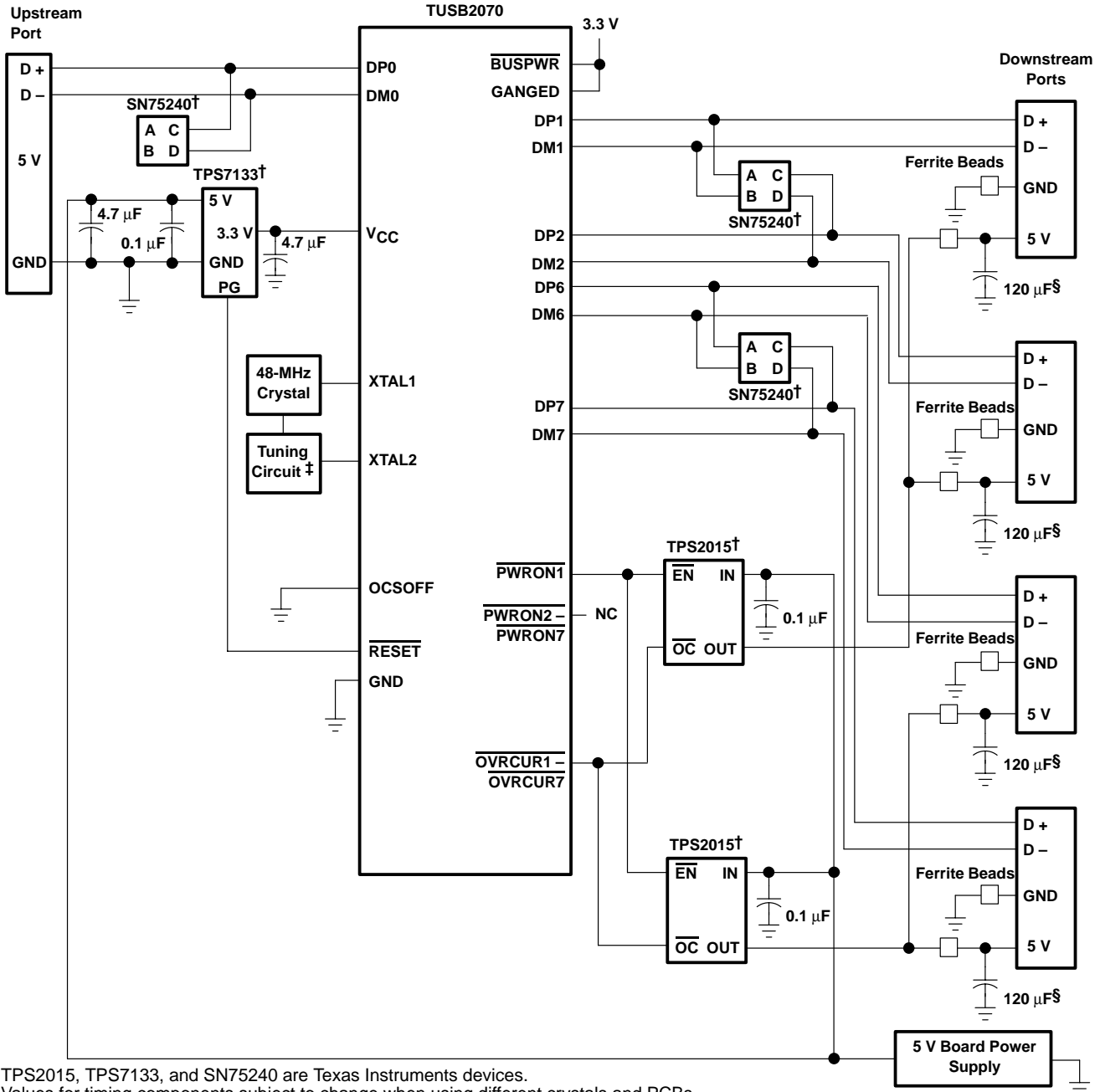

† TPS2015, TPS7133, and SN75240 are Texas Instruments devices.

‡ Values for timing components subject to change when using different crystals and PCBs.

§ Minimum value required per USB specification, version 1.0.

Figure 9. TUSB2070 Self-Powered Hub, Ganged Port Power Management Application

APPLICATION INFORMATION

self-powered hub, individual port power management

A self-powered TUSB2070 supports seven downstream ports and is capable of supplying 500 mA of current for low-power or high-power device class functions to each downstream port (Ports 3–5 are not shown in Figure 10 but should be connected similarly to ports shown). Self-powered hubs are required to implement overcurrent protection. Individual-port power management (see Figure 10) utilizes the TPS2014 power switching and overcurrent protection that provide maximum robustness to the hub system. When the hub detects a downstream port fault, power is removed from the faulty port only, thus allowing other ports to continue normal operation. Individual SN75240 transient suppressors reduce in-rush current and voltage spikes.

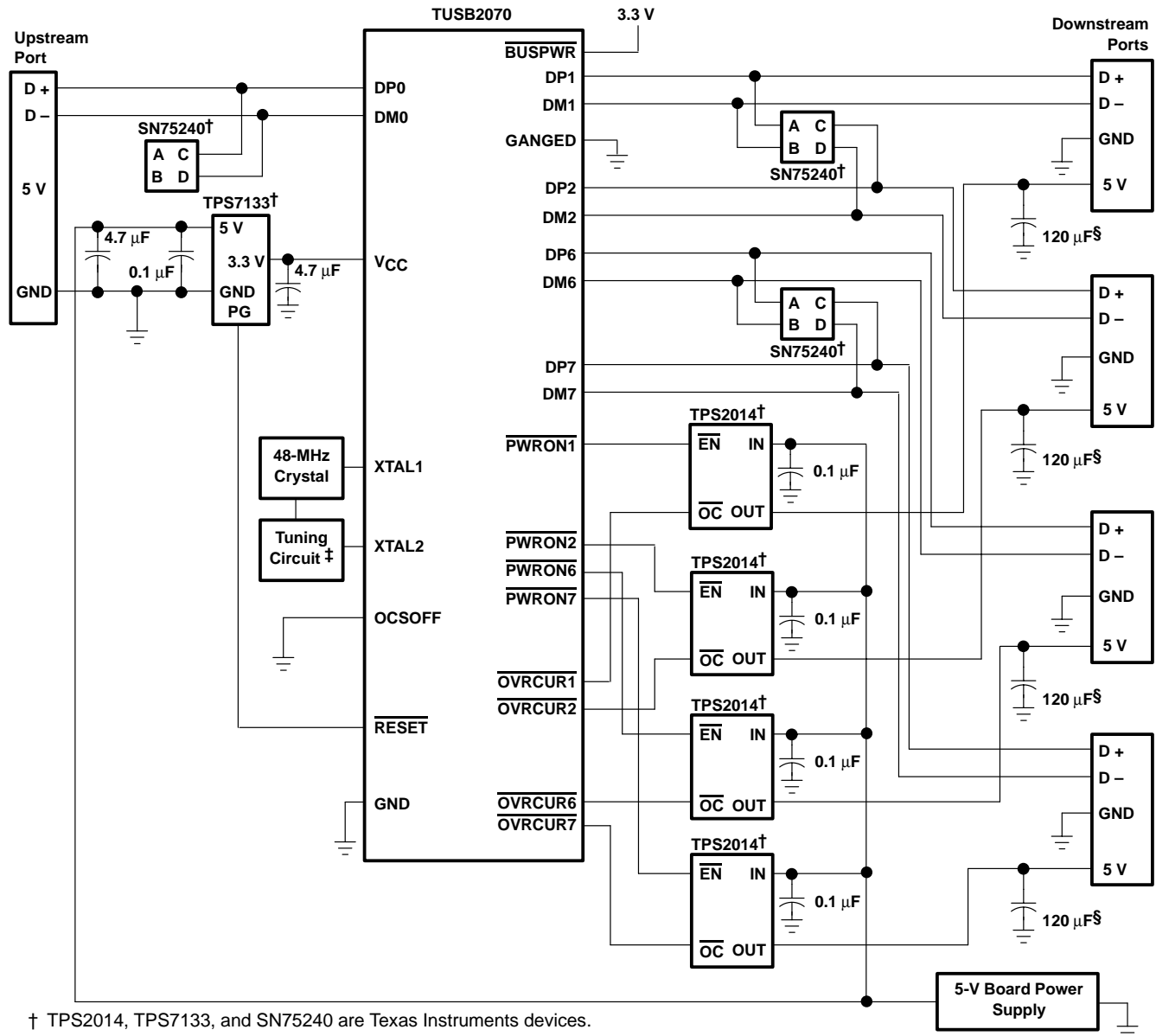

† TPS2014, TPS7133, and SN75240 are Texas Instruments devices.

‡ Values for timing components are subject to change when using different crystals and PCBs.

§ Minimum value required per USB specification, version 1.0.

Figure 10. TUSB2070 Self-Powered Hub, Individual-Port Power Management Application

TUSB2070 7-PORT HUB FOR THE UNIVERSAL SERIAL BUS

SLLS239B – NOVEMBER 1996 – REVISED AUGUST 1997

MECHANICAL DATA

PT (S-PQFP-G48)

PLASTIC QUAD FLATPACK

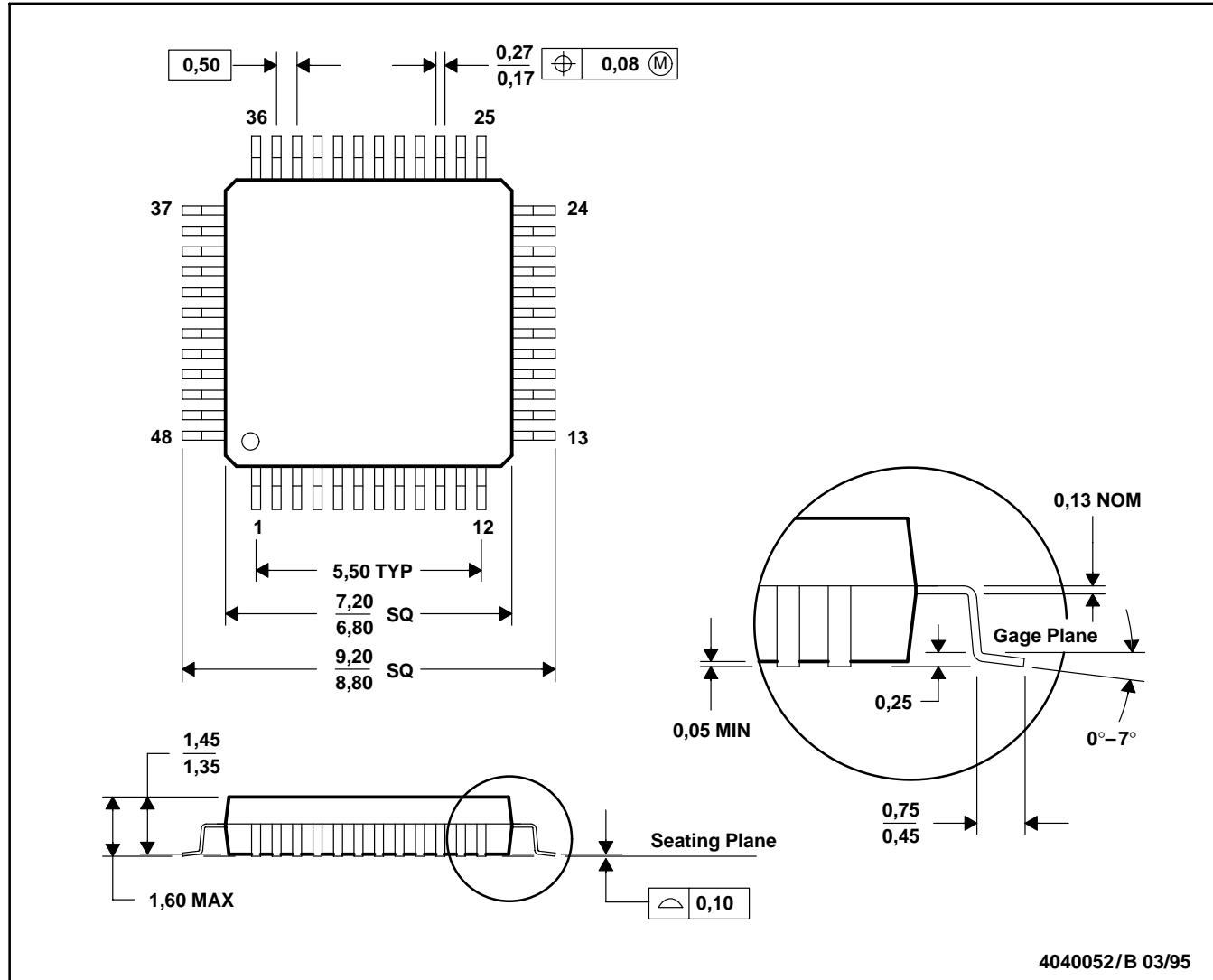

- NOTES:
- All linear dimensions are in millimeters.
 - This drawing is subject to change without notice.
 - Falls within JEDEC MO-136
 - This may also be a thermally enhanced plastic package with leads connected to the die pads.

IMPORTANT NOTICE

Texas Instruments (TI) reserves the right to make changes to its products or to discontinue any semiconductor product or service without notice, and advises its customers to obtain the latest version of relevant information to verify, before placing orders, that the information being relied on is current.

TI warrants performance of its semiconductor products and related software to the specifications applicable at the time of sale in accordance with TI's standard warranty. Testing and other quality control techniques are utilized to the extent TI deems necessary to support this warranty. Specific testing of all parameters of each device is not necessarily performed, except those mandated by government requirements.

Certain applications using semiconductor products may involve potential risks of death, personal injury, or severe property or environmental damage ("Critical Applications").

TI SEMICONDUCTOR PRODUCTS ARE NOT DESIGNED, INTENDED, AUTHORIZED, OR WARRANTED TO BE SUITABLE FOR USE IN LIFE-SUPPORT APPLICATIONS, DEVICES OR SYSTEMS OR OTHER CRITICAL APPLICATIONS.

Inclusion of TI products in such applications is understood to be fully at the risk of the customer. Use of TI products in such applications requires the written approval of an appropriate TI officer. Questions concerning potential risk applications should be directed to TI through a local SC sales office.

In order to minimize risks associated with the customer's applications, adequate design and operating safeguards should be provided by the customer to minimize inherent or procedural hazards.

TI assumes no liability for applications assistance, customer product design, software performance, or infringement of patents or services described herein. Nor does TI warrant or represent that any license, either express or implied, is granted under any patent right, copyright, mask work right, or other intellectual property right of TI covering or relating to any combination, machine, or process in which such semiconductor products or services might be or are used.