

# SN55LVDS31, SN65LVDS31, SN65LVDS3487, SN65LVDS9638 HIGH-SPEED DIFFERENTIAL LINE DRIVERS

SLLS261D – JULY 1997 – REVISED DECEMBER 1998

- Meets or Exceeds the Requirements of ANSI TIA/EIA-644 Standard
- Low-Voltage Differential Signaling with Typical Output Voltage of 350 mV and a 100-Ω Load
- Typical Output Voltage Rise and Fall Times of 500 ps (400 Mbps)
- Typical Propagation Delay Times of 1.7 ns
- Operates from a Single 3.3-V Supply
- Power Dissipation 25 mW Typical per Driver at 200 MHz
- Driver at High Impedance when Disabled or with  $V_{CC} = 0$
- Bus-Terminal ESD Protection Exceeds 8 kV
- Low-Voltage TTL (LVTTTL) Logic Input Levels
- Pin-Compatible with the AM26LS31, MC3487, and  $\mu$ A9638

## description

The SN55LVDS31, SN65LVDS31, SN65LVDS3487, and SN65LVDS9638 are differential line drivers that implement the electrical characteristics of low-voltage differential signaling (LVDS). This signaling technique lowers the output voltage levels of 5 V differential standard levels (such as TIA/EIA-422B) to reduce the power, increase the switching speeds, and allow operation with a 3.3-V supply rail. Any of the four current-mode drivers will deliver a minimum differential output voltage magnitude of 247 mV into a 100-Ω load when enabled.

The intended application of these devices and signaling technique is for point-to-point baseband data transmission over controlled impedance media of approximately 100 Ω. The transmission media may be printed-circuit board traces, backplanes, or cables. The ultimate rate and distance of data transfer is dependent upon the attenuation characteristics of the media and the noise coupling to the environment.

The SN65LVDS31, SN65LVDS3487, and SN65LVDS9638 are characterized for operation from  $-40^{\circ}\text{C}$  to  $85^{\circ}\text{C}$ . The SN55LVDS31 is characterized for operation from  $-55^{\circ}\text{C}$  to  $125^{\circ}\text{C}$ .

SN55LVDS31, SN65LVDS31  
D, J, OR W PACKAGE  
(TOP VIEW)

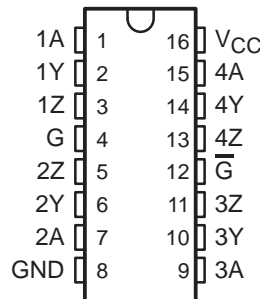

SN55LVDS31  
FK PACKAGE  
(TOP VIEW)

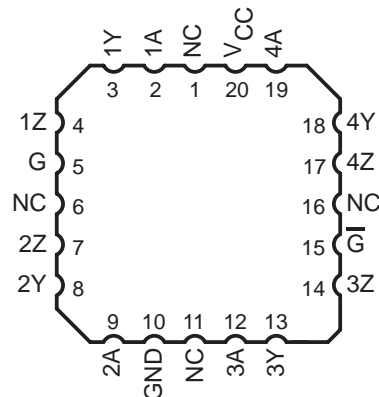

SN65LVDS3487  
D PACKAGE  
(TOP VIEW)

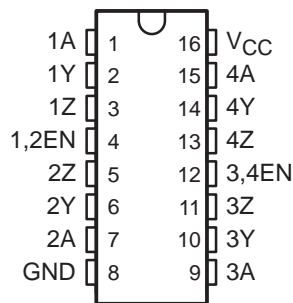

SN65LVDS9638  
D OR DGN PACKAGE  
(TOP VIEW)

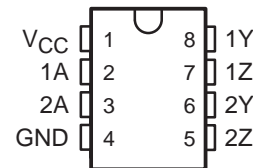

Please be aware that an important notice concerning availability, standard warranty, and use in critical applications of Texas Instruments semiconductor products and disclaimers thereto appears at the end of this data sheet.

PRODUCTION DATA information is current as of publication date. Products conform to specifications per the terms of Texas Instruments standard warranty. Production processing does not necessarily include testing of all parameters.



POST OFFICE BOX 655303 • DALLAS, TEXAS 75265

Copyright © 1998, Texas Instruments Incorporated

# SN55LVDS31, SN65LVDS31, SN65LVDS3487, SN65LVDS9638 HIGH-SPEED DIFFERENTIAL LINE DRIVERS

SLLS261D – JULY 1997 – REVISED DECEMBER 1998

## AVAILABLE OPTIONS

T <sub>A</sub>	PACKAGE				
	SMALL OUTLINE (D)	MSOP (DGN)	CHIP CARRIER (FK)	CERAMIC DIP (J)	FLAT PACK (W)
-40°C to 85°C	SN65LVDS31D	—	—	—	—
	SN65LVDS3487D	—	—	—	—
	SN65LVDS9638D	SN65LVDS9638DGN	—	—	—
-55°C to 125°C	—	—	SN55LVDS31FK	SN55LVDS31J	SN55LVDS31W

### logic symbol†

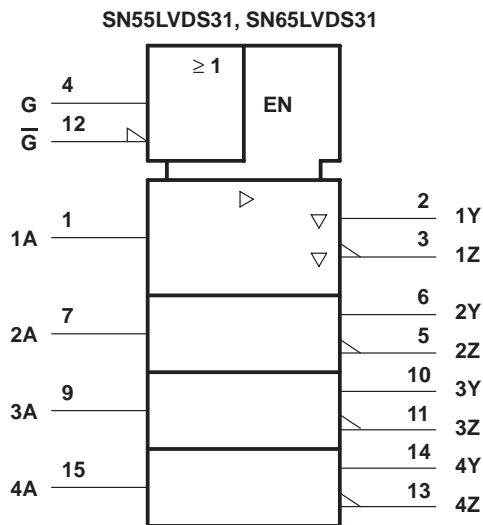

### 'LVDS31 logic diagram (positive logic)

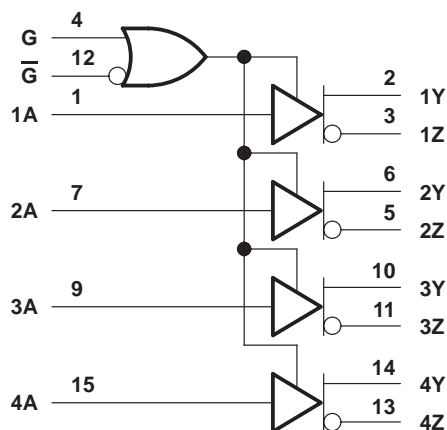

† This symbol is in accordance with ANSI/IEEE Std 91-1984 and IEC Publication 617-12.

# SN55LVDS31, SN65LVDS31, SN65LVDS3487, SN65LVDS9638 HIGH-SPEED DIFFERENTIAL LINE DRIVERS

SLLS261D – JULY 1997 – REVISED DECEMBER 1998

## logic symbol†

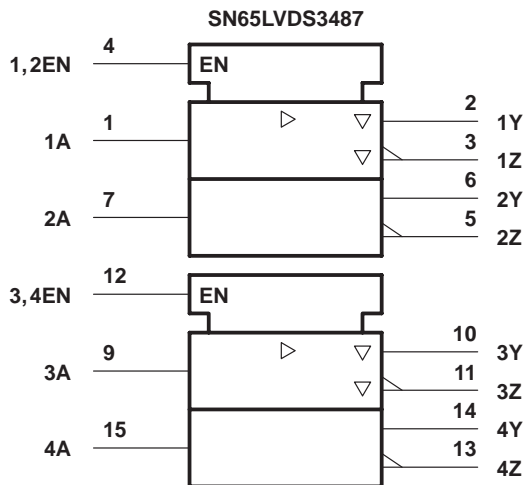

† This symbol is in accordance with ANSI/IEEE Std 91-1984 and IEC Publication 617-12.

## 'LVDS3487 logic diagram (positive logic)

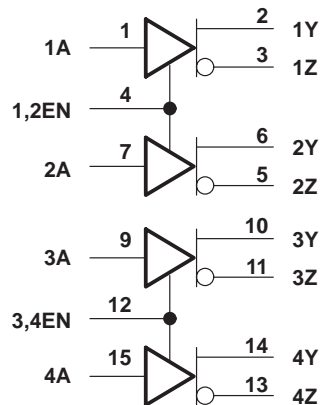

## logic symbol†

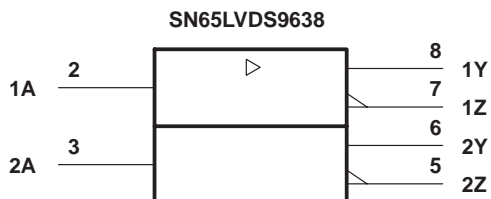

† This symbol is in accordance with ANSI/IEEE Std 91-1984 and IEC Publication 617-12.

## 'LVDS9638 logic diagram (positive logic)

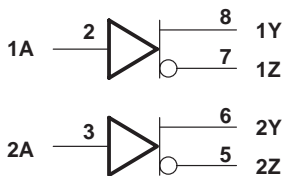

# SN55LVDS31, SN65LVDS31, SN65LVDS3487, SN65LVDS9638 HIGH-SPEED DIFFERENTIAL LINE DRIVERS

SLLS261D – JULY 1997 – REVISED DECEMBER 1998

## Function Tables

SN55LVDS31, SN65LVDS31

INPUT A	ENABLES		OUTPUTS	
	G	$\bar{G}$	Y	Z
H	H	X	H	L
L	H	X	L	H
H	X	L	H	L
L	X	L	L	H
X	L	H	Z	Z
Open	H	X	L	H
Open	X	L	L	H

H = high level, L = low level, X = irrelevant,  
Z = high impedance (off)

SN65LVDS3487

INPUT A	ENABLE	OUTPUTS	
	EN	Y	Z
H	H	H	L
L	H	L	H
X	L	Z	Z
OPEN	H	L	H

H = high level, L = low level, X = irrelevant,  
Z = high impedance (off)

SN65LVDS9638

INPUT A	OUTPUTS	
	Y	Z
H	H	L
L	L	H
OPEN	L	H

H = high level, L = low level

# SN55LVDS31, SN65LVDS31, SN65LVDS3487, SN65LVDS9638 HIGH-SPEED DIFFERENTIAL LINE DRIVERS

SLLS261D – JULY 1997 – REVISED DECEMBER 1998

## equivalent input and output schematic diagrams

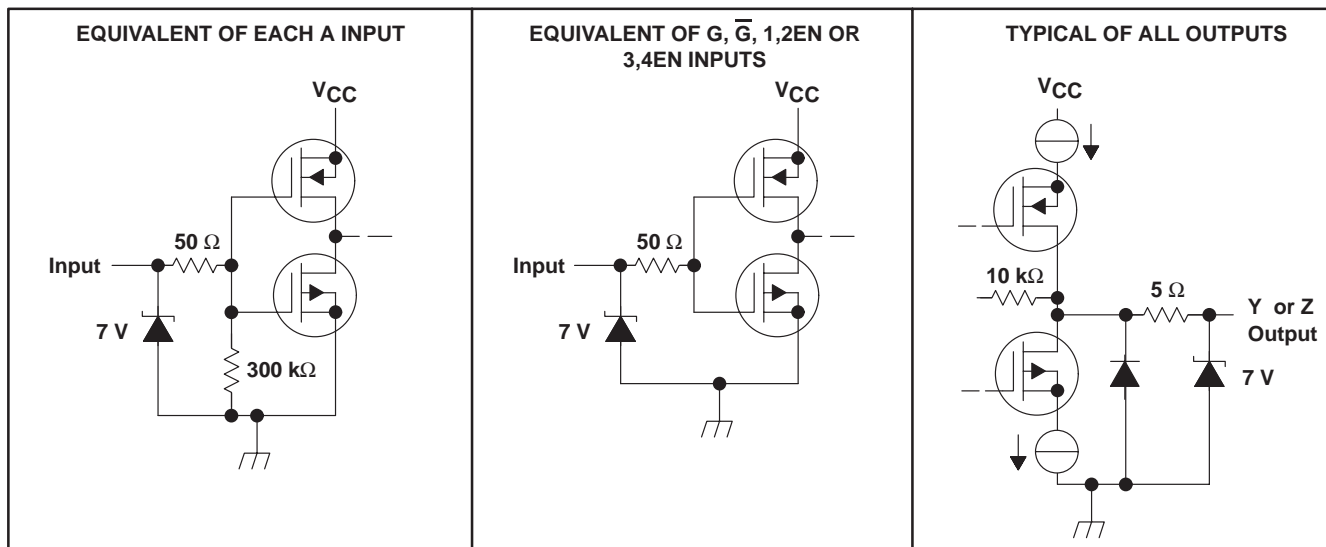

## absolute maximum ratings over operating free-air temperature range (unless otherwise noted)†

Supply voltage range, $V_{CC}$ (see Note 1)	–0.5 V to 4 V
Input voltage range, $V_I$	–0.5 V to $V_{CC} + 0.5$ V
Continuous total power dissipation	See Dissipation Rating Table
Storage temperature range, $T_{stg}$	–65°C to 150°C
Lead temperature 1,6 mm (1/16 inch) from case for 10 seconds	260°C

† Stresses beyond those listed under “absolute maximum ratings” may cause permanent damage to the device. These are stress ratings only, and functional operation of the device at these or any other conditions beyond those indicated under “recommended operating conditions” is not implied. Exposure to absolute-maximum-rated conditions for extended periods may affect device reliability.

NOTE 1: All voltages, except differential I/O bus voltages, are with respect to the network ground terminal.

DISSIPATION RATING TABLE

PACKAGE	$T_A \leq 25^\circ\text{C}$ POWER RATING	DERATING FACTOR‡ ABOVE $T_A = 25^\circ\text{C}$	$T_A = 70^\circ\text{C}$ POWER RATING	$T_A = 85^\circ\text{C}$ POWER RATING	$T_A = 125^\circ\text{C}$ POWER RATING
D (8)	725 mW	5.8 mW/°C	464 mW	377 mW	—
D (16)	950 mW	7.6 mW/°C	608 mW	494 mW	—
DGN	2.14 W	17.1 mW/°C	1.37 W	1.11 W	—
FK	1375 mW	11.0 mW/°C	880 mW	715 mW	275 mW
J	1375 mW	11.0 mW/°C	880 mW	715 mW	275 mW
W	1000 mW	8.0 mW/°C	640 mW	520 mW	200 mW

‡ This is the inverse of the junction-to-ambient thermal resistance when board-mounted and with no air flow.

## recommended operating conditions

	MIN	NOM	MAX	UNIT
Supply voltage, $V_{CC}$	3	3.3	3.6	V
High-level input voltage, $V_{IH}$	2			V
Low-level input voltage, $V_{IL}$			0.8	V
Operating free-air temperature, $T_A$	SN65 prefix	–40	85	°C
	SN55 prefix	–55	125	



# SN55LVDS31, SN65LVDS31, SN65LVDS3487, SN65LVDS9638 HIGH-SPEED DIFFERENTIAL LINE DRIVERS

SLLS261D – JULY 1997 – REVISED DECEMBER 1998

## SN65LVDSxxxx electrical characteristics over recommended operating conditions (unless otherwise noted)

PARAMETER		TEST CONDITIONS	SN65LVDS31, SN65LVDS3487, SN65LVDS9638			UNIT	
			MIN	TYP†	MAX		
V <sub>OD</sub>	Differential output voltage magnitude	R <sub>L</sub> = 100 Ω, See Figure 2	247	340	454	mV	
ΔV <sub>OD</sub>	Change in differential output voltage magnitude between logic states		-50		50	mV	
ΔV <sub>OC(SS)</sub>	Change in steady-state common-mode output voltage between logic states	See Figure 3	1.125	1.2	1.375	V	
V <sub>OC(SS)</sub>	Steady-state common-mode output voltage		-50		50	mV	
V <sub>OC(PP)</sub>	Peak-to-peak common-mode output voltage		50		150	mV	
I <sub>CC</sub>	Supply current	V <sub>I</sub> = 0.8 V or 2 V, Enabled, No load	SN65LVDS31, '3487		9	20	mA
			SN65LVDS9638		25	35	mA
		V <sub>I</sub> = 0 or V <sub>CC</sub> , Disabled	SN65LVDS31, '3487		0.25	1	mA
			SN65LVDS9638		4.7	8	mA
I <sub>IH</sub>	High-level input current	V <sub>IH</sub> = 2		4	20	μA	
I <sub>IL</sub>	Low-level input current	V <sub>IL</sub> = 0.8 V		0.1	10	μA	
I <sub>OS</sub>	Short-circuit output current	V <sub>O(Y)</sub> or V <sub>O(Z)</sub> = 0		-4	-24	mA	
		V <sub>OD</sub> = 0			±12	mA	
I <sub>OZ</sub>	High-impedance output current	V <sub>O</sub> = 0 or 2.4 V			±1	μA	
I <sub>O(OFF)</sub>	Power-off output current	V <sub>CC</sub> = 0, V <sub>O</sub> = 2.4 V			±1	μA	
C <sub>I</sub>	Input capacitance			3		pF	

† All typical values are at T<sub>A</sub> = 25°C and with V<sub>CC</sub> = 3.3 V.

## SN65LVDSxxxx switching characteristics over recommended operating conditions (unless otherwise noted)

PARAMETER		TEST CONDITIONS	SN65LVDS31, SN65LVDS3487, SN65LVDS9638			UNIT
			MIN	TYP†	MAX	
t <sub>pLH</sub>	Propagation delay time, low-to-high-level output	R <sub>L</sub> = 100 Ω, C <sub>L</sub> = 10 pF, See Figure 2	0.5	1.4	2	ns
t <sub>pHL</sub>	Propagation delay time, high-to-low-level output		1	1.7	2.5	ns
t <sub>r</sub>	Differential output signal rise time (20% to 80%)		0.4	0.5	0.6	ns
t <sub>f</sub>	Differential output signal fall time (80% to 20%)		0.4	0.5	0.6	ns
t <sub>sk(p)</sub>	Pulse skew ( t <sub>pHL</sub> - t <sub>pLH</sub>  )			0.3	0.6	ns
t <sub>sk(o)</sub>	Channel-to-channel output skew‡			0	0.3	ns
t <sub>pZH</sub>	Propagation delay time, high-impedance-to-high-level output	See Figure 4		5.4	15	ns
t <sub>pZL</sub>	Propagation delay time, high-impedance-to-low-level output			2.5	15	ns
t <sub>pHZ</sub>	Propagation delay time, high-level-to-high-impedance output			8.1	15	ns
t <sub>pLZ</sub>	Propagation delay time, low-level-to-high-impedance output			7.3	15	ns

† All typical values are at T<sub>A</sub> = 25°C and with V<sub>CC</sub> = 3.3 V.

‡ t<sub>sk(o)</sub> is the maximum delay time difference between drivers on the same device.



# SN55LVDS31, SN65LVDS31, SN65LVDS3487, SN65LVDS9638 HIGH-SPEED DIFFERENTIAL LINE DRIVERS

SLLS261D – JULY 1997 – REVISED DECEMBER 1998

## SN55LVDS31 electrical characteristics over recommended operating conditions (unless otherwise noted)

PARAMETER	TEST CONDITIONS	SN55LVDS31			UNIT	
		MIN	TYP†	MAX		
V <sub>OD</sub>	Differential output voltage magnitude	247	340	454	mV	
ΔV <sub>OD</sub>	Change in differential output voltage magnitude between logic states	R <sub>L</sub> = 100 Ω, See Figure 2		-50	50	mV
V <sub>OC(SS)</sub>	Steady-state common-mode output voltage	1.125	1.2	1.375	V	
ΔV <sub>OC(SS)</sub>	Change in steady-state common-mode output voltage between logic states	See Figure 3		-50	50	mV
V <sub>OC(PP)</sub>	Peak-to-peak common-mode output voltage		50	150	mV	
I <sub>CC</sub>	Supply current	V <sub>I</sub> = 0.8 V or 2 V, Enabled, No load	9	20	mA	
		V <sub>I</sub> = 0.8 or 2 V, Enabled, R <sub>L</sub> = 100 Ω	25	35	mA	
		V <sub>I</sub> = 0 or V <sub>CC</sub> , Disabled	0.25	1	mA	
I <sub>IH</sub>	High-level input current	V <sub>IH</sub> = 2		4	20	μA
I <sub>IL</sub>	Low-level input current	V <sub>IL</sub> = 0.8 V		0.1	10	μA
I <sub>OS</sub>	Short-circuit output current	V <sub>O(Y)</sub> or V <sub>O(Z)</sub> = 0		-4	-24	mA
		V <sub>OD</sub> = 0			±12	mA
I <sub>OZ</sub>	High-impedance output current	V <sub>O</sub> = 0 or 2.4 V			±1	μA
I <sub>O(OFF)</sub>	Power-off output current	V <sub>CC</sub> = 0, V <sub>O</sub> = 2.4 V			±4	μA
C <sub>I</sub>	Input capacitance		3		pF	

† All typical values are at T<sub>A</sub> = 25°C and with V<sub>CC</sub> = 3.3 V.

## SN55LVDS31 switching characteristics over recommended operating conditions (unless otherwise noted)

PARAMETER	TEST CONDITIONS	SN55LVDS31			UNIT		
		MIN	TYP†	MAX			
t <sub>pLH</sub>	Propagation delay time, low-to-high-level output	0.5	1.4	4	ns		
t <sub>pHL</sub>	Propagation delay time, high-to-low-level output	1	1.7	4.5	ns		
t <sub>r</sub>	Differential output signal rise time (20% to 80%)	R <sub>L</sub> = 100 Ω, C <sub>L</sub> = 10 pF, See Figure 2		0.4	0.5	1	ns
t <sub>f</sub>	Differential output signal fall time (80% to 20%)			0.4	0.5	1	ns
t <sub>sk(p)</sub>	Pulse skew ( t <sub>pHL</sub> - t <sub>pLH</sub>  )			0.3	0.6	ns	
t <sub>sk(o)</sub>	Channel-to-channel output skew‡			0.3	0.6	ns	
t <sub>pZH</sub>	Propagation delay time, high-impedance-to-high-level output	See Figure 4		5.4	15	ns	
t <sub>pZL</sub>	Propagation delay time, high-impedance-to-low-level output			2.5	15	ns	
t <sub>pHZ</sub>	Propagation delay time, high-level-to-high-impedance output			8.1	17	ns	
t <sub>pLZ</sub>	Propagation delay time, low-level-to-high-impedance output			7.3	15	ns	

† All typical values are at T<sub>A</sub> = 25°C and with V<sub>CC</sub> = 3.3 V.

‡ t<sub>sk(o)</sub> is the maximum delay time difference between drivers on the same device.



# SN55LVDS31, SN65LVDS31, SN65LVDS3487, SN65LVDS9638 HIGH-SPEED DIFFERENTIAL LINE DRIVERS

SLLS261D – JULY 1997 – REVISED DECEMBER 1998

## PARAMETER MEASUREMENT INFORMATION

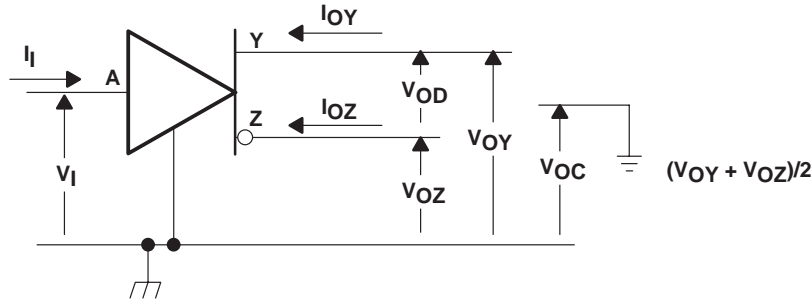
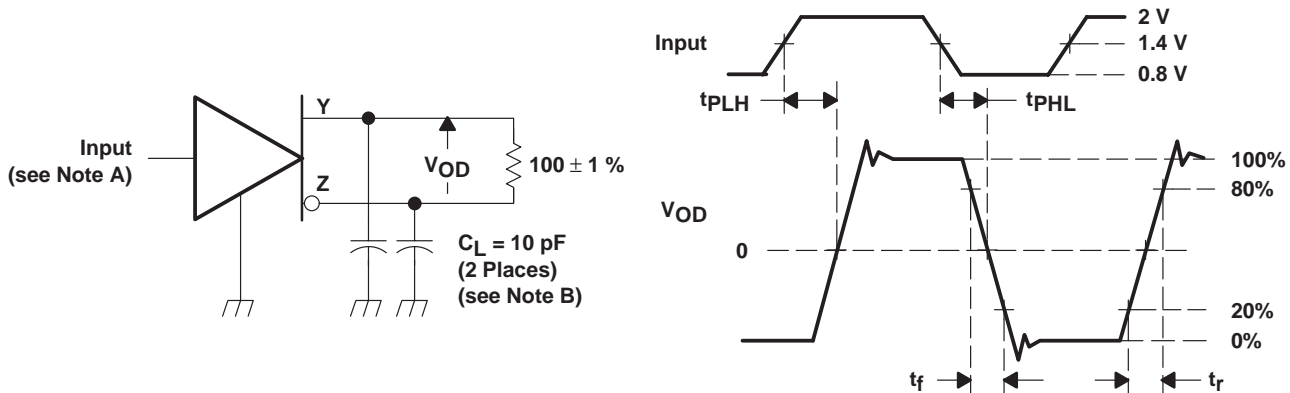
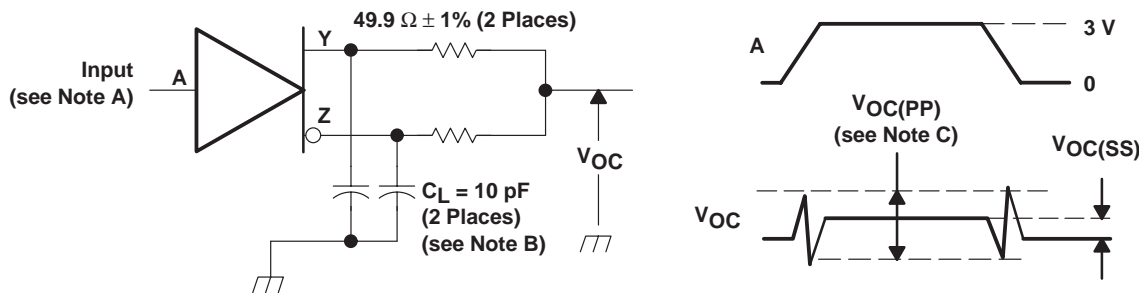

Figure 1. Voltage and Current Definitions



- NOTES: A. All input pulses are supplied by a generator having the following characteristics:  $t_r$  or  $t_f \leq 1$  ns, pulse repetition rate (PRR) = 50 Mpps, pulse width =  $10 \pm 0.2$  ns.  
B.  $C_L$  includes instrumentation and fixture capacitance within 6 mm of the D.U.T.

Figure 2. Test Circuit, Timing, and Voltage Definitions for the Differential Output Signal



- NOTES: A. All input pulses are supplied by a generator having the following characteristics:  $t_r$  or  $t_f \leq 1$  ns, pulse repetition rate (PRR) = 50 Mpps, pulse width =  $10 \pm 0.2$  ns.  
B.  $C_L$  includes instrumentation and fixture capacitance within 6 mm of the D.U.T.  
C. The measurement of  $V_{OC(PP)}$  is made on test equipment with a  $-3$  dB bandwidth of at least 300 MHz.

Figure 3. Test Circuit and Definitions for the Driver Common-Mode Output Voltage



PARAMETER MEASUREMENT INFORMATION

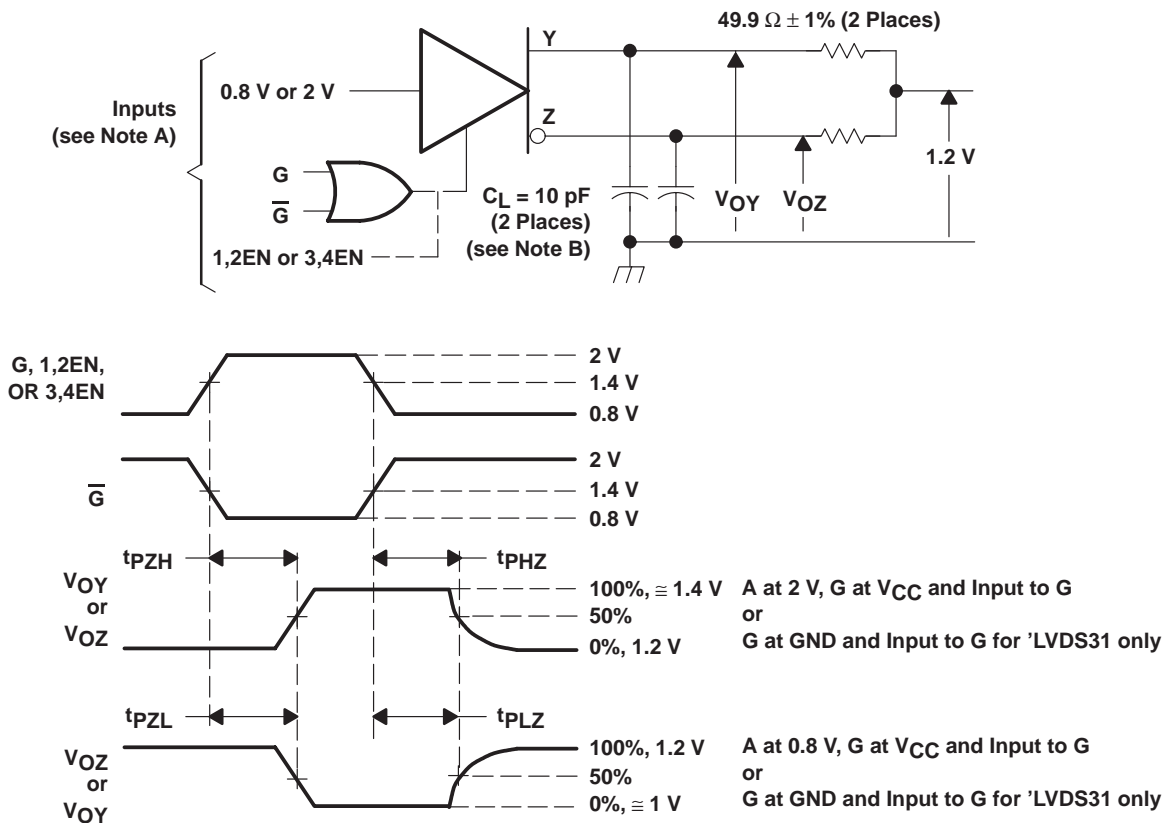

- NOTES: A. All input pulses are supplied by a generator having the following characteristics:  $t_r$  or  $t_f < 1 \text{ ns}$ , pulse repetition rate (PRR) = 0.5 Mpps, pulse width =  $500 \pm 10 \text{ ns}$ .  
B.  $C_L$  includes instrumentation and fixture capacitance within 6 mm of the D.U.T.

Figure 4. Enable and Disable Time Circuit and Definitions

# SN55LVDS31, SN65LVDS31, SN65LVDS3487, SN65LVDS9638 HIGH-SPEED DIFFERENTIAL LINE DRIVERS

SLLS261D – JULY 1997 – REVISED DECEMBER 1998

## TYPICAL CHARACTERISTICS

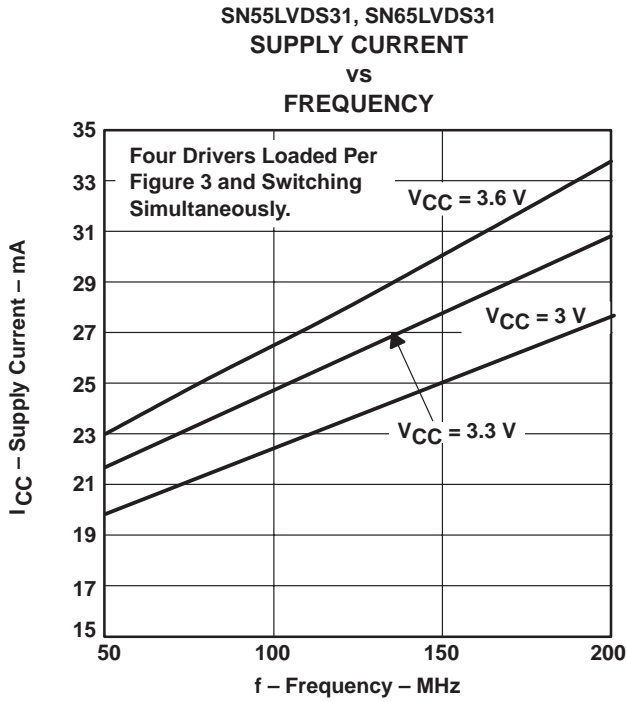

Figure 5

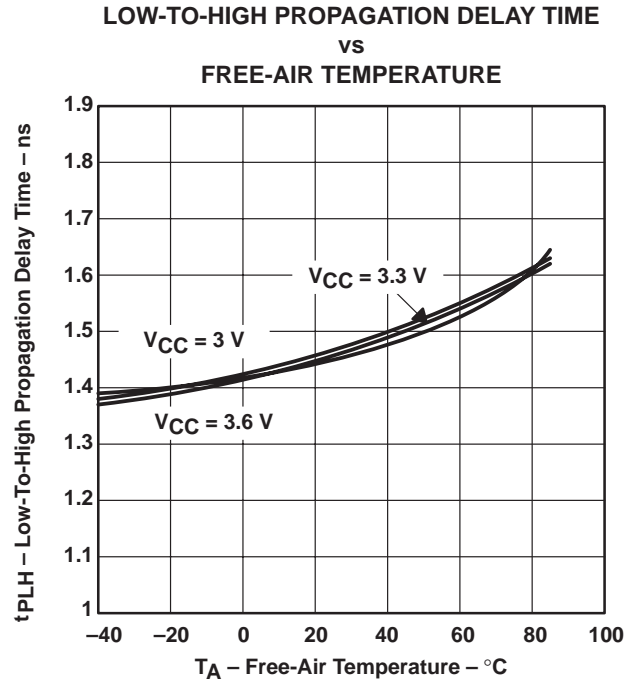

Figure 6

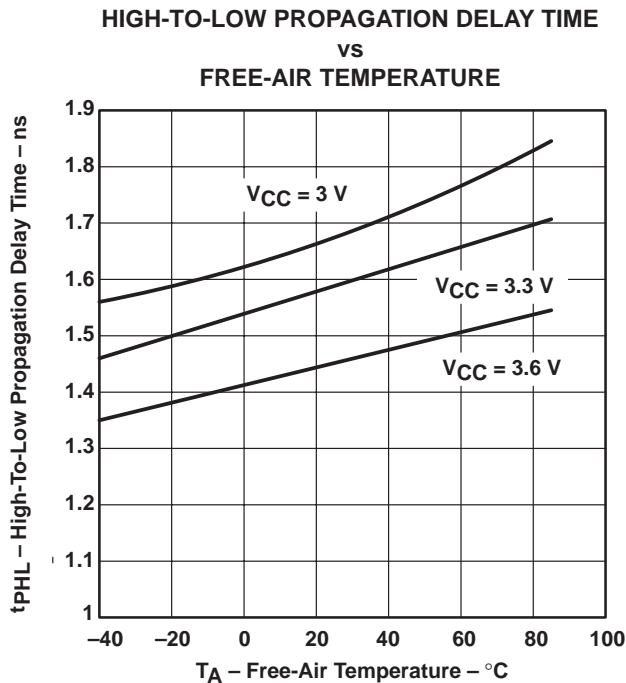
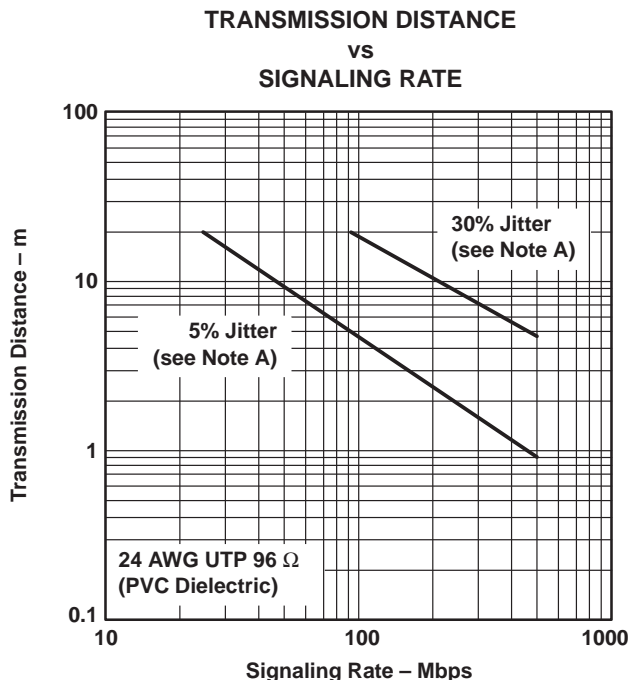

Figure 7



APPLICATIONS INFORMATION

The devices are generally used as building blocks for high-speed point-to-point data transmission where ground differences are less than 1 V. Devices can interoperate with RS-422, PECL, and IEEE-P1596. Drivers/receivers approach ECL speeds without the power and dual supply requirements.



NOTE A: This parameter is the percentage of distortion of the unit interval (UI) with a pseudo-random data pattern.

Figure 8. Typical Transmission Distance Versus Signaling Rate

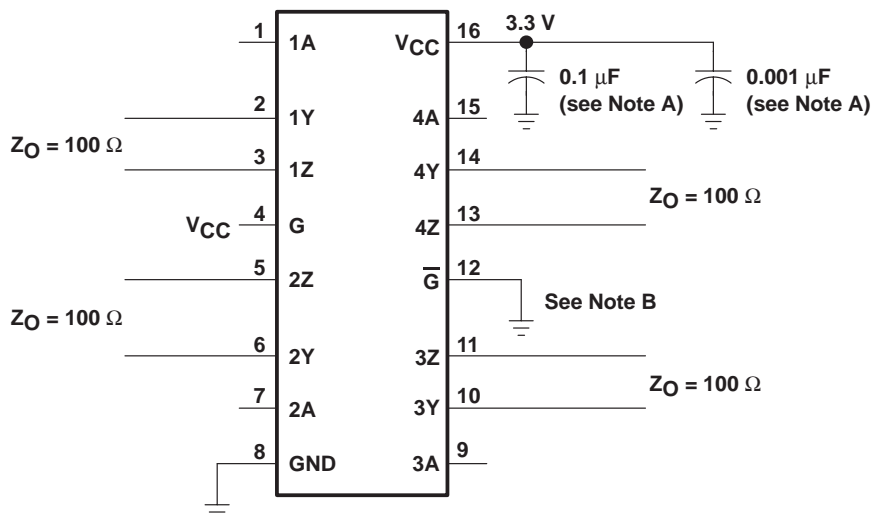

NOTES: A. Place a 0.1  $\mu\text{F}$  and a 0.001  $\mu\text{F}$  Z5U ceramic, mica or polystyrene dielectric, 0805 size, chip capacitor between  $V_{CC}$  and the ground plane. The capacitors should be located as close as possible to the device terminals.  
B. Unused enable inputs should be tied to  $V_{CC}$  or GND as appropriate.

Figure 9. Typical Application Circuit Schematic

# SN55LVDS31, SN65LVDS31, SN65LVDS3487, SN65LVDS9638 HIGH-SPEED DIFFERENTIAL LINE DRIVERS

SLLS261D – JULY 1997 – REVISED DECEMBER 1998

## APPLICATIONS INFORMATION

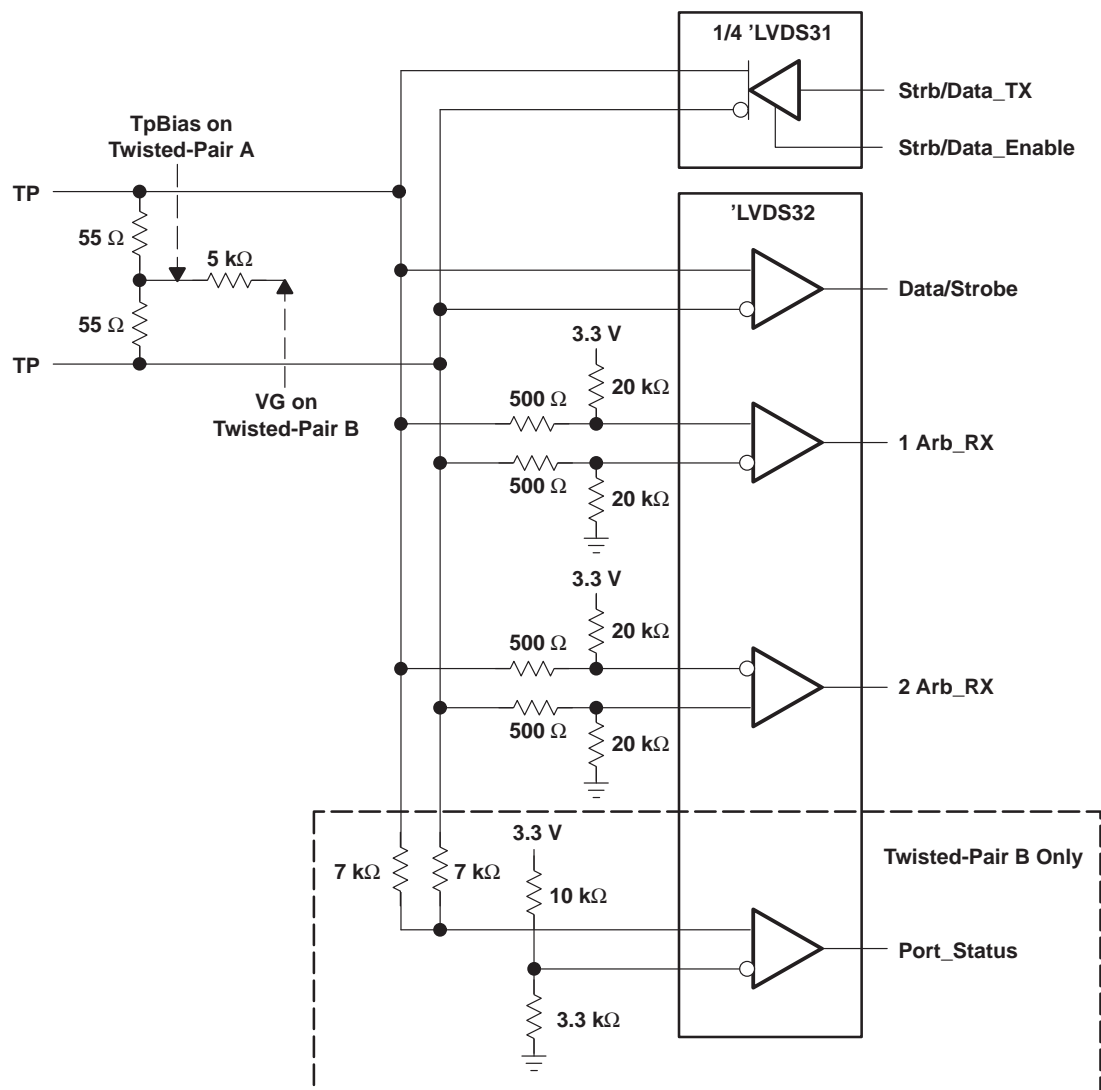

- NOTES: A. Resistors are leadless thick-film (0603) 5% tolerance.  
 B. Decoupling capacitance is not shown but recommended.  
 C.  $V_{CC}$  is 3 V to 3.6 V.  
 D. The differential output voltage of the 'LVDS31 can exceed that specified by IEEE1394.

**Figure 10. 100 Mbps IEEE1394 Transceiver**

APPLICATIONS INFORMATION

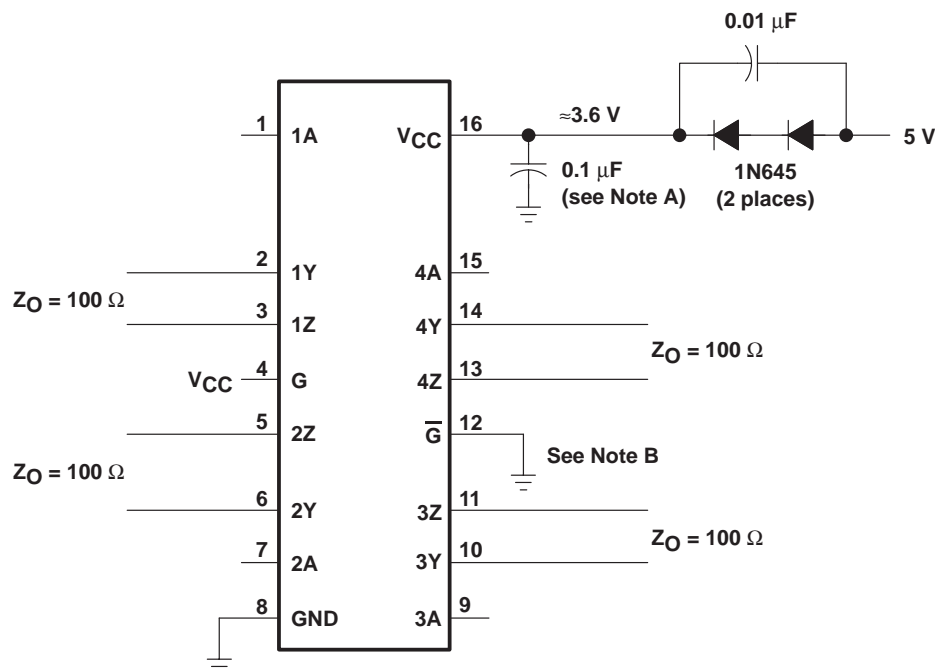

NOTE A: Place a 0.1 μF Z5U ceramic, mica or polystyrene dielectric, 0805 size, chip capacitor between V<sub>CC</sub> and the ground plane. The capacitor should be located as close as possible to the device terminals.

Figure 11. Operation with a 5-V Supply

related information

IBIS modeling is available for this device. Please contact the local TI sales office or the TI Web site at [www.ti.com](http://www.ti.com) for more information.

For more application guidelines, please see the following documents:

- *Low-Voltage Differential Signalling Design Notes* (TI literature number SLLA014)
- *Interface Circuits for TIA/EIA-644 (LVDS)* (SLLA038)
- *Reducing EMI with LVDS* (SLLA030)
- *Slew Rate Control of LVDS Circuits* (SLLA034)
- *Using an LVDS Receiver with RS-422 Data* (SLLA031)
- *Evaluating the LVDS EVM* (SLLA033)

# SN55LVDS31, SN65LVDS31, SN65LVDS3487, SN65LVDS9638 HIGH-SPEED DIFFERENTIAL LINE DRIVERS

SLLS261D – JULY 1997 – REVISED DECEMBER 1998

## MECHANICAL INFORMATION

D (R-PDSO-G\*\*)

PLASTIC SMALL-OUTLINE PACKAGE

14 PIN SHOWN

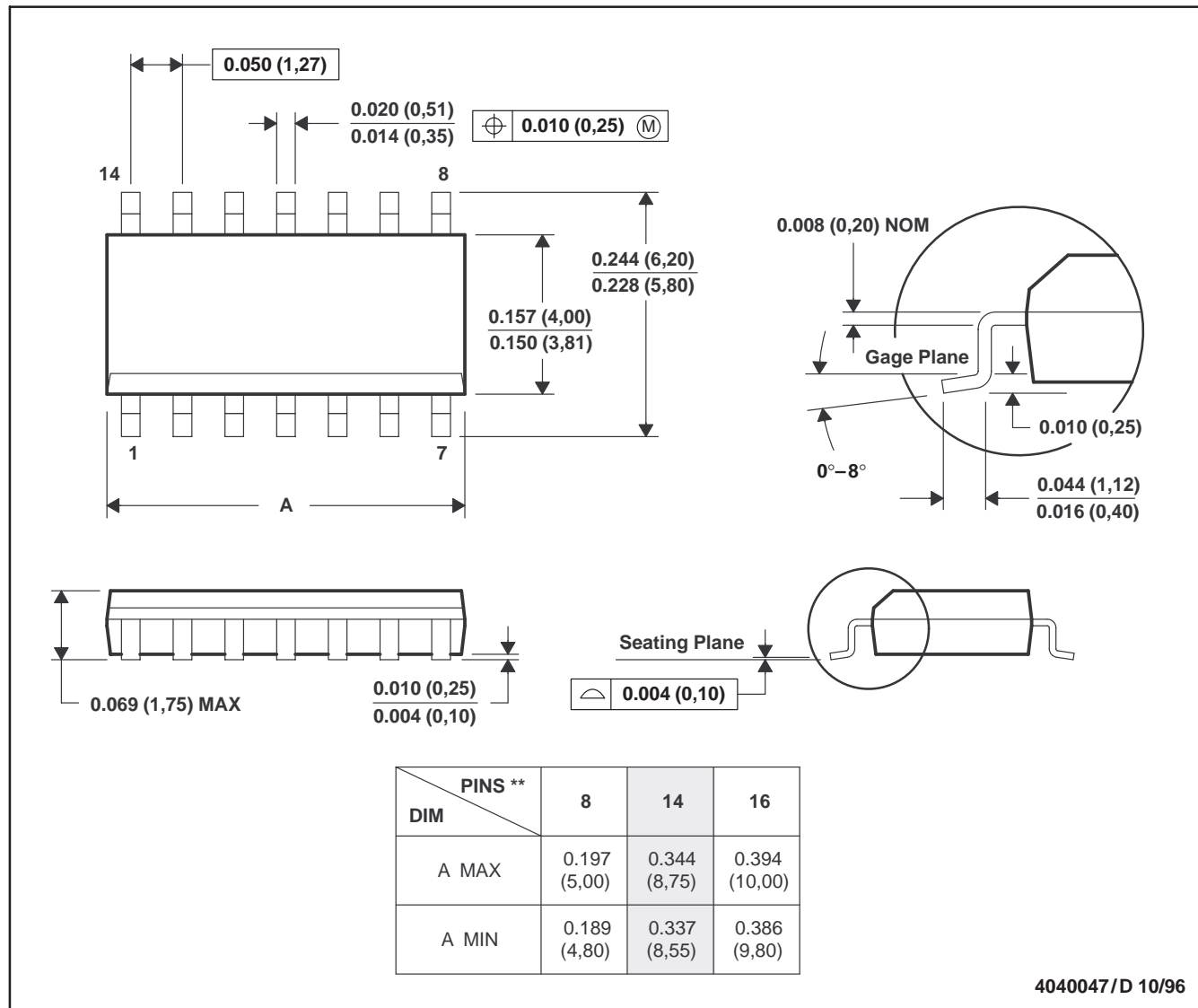

- NOTES: A. All linear dimensions are in inches (millimeters).  
 B. This drawing is subject to change without notice.  
 C. Body dimensions do not include mold flash or protrusion, not to exceed 0.006 (0,15).  
 D. Falls within JEDEC MS-012

# SN55LVDS31, SN65LVDS31, SN65LVDS3487, SN65LVDS9638 HIGH-SPEED DIFFERENTIAL LINE DRIVERS

SLLS261D – JULY 1997 – REVISED DECEMBER 1998

## MECHANICAL INFORMATION

DGN (S-PDSO-G8)

PowerPAD™ PLASTIC SMALL-OUTLINE PACKAGE

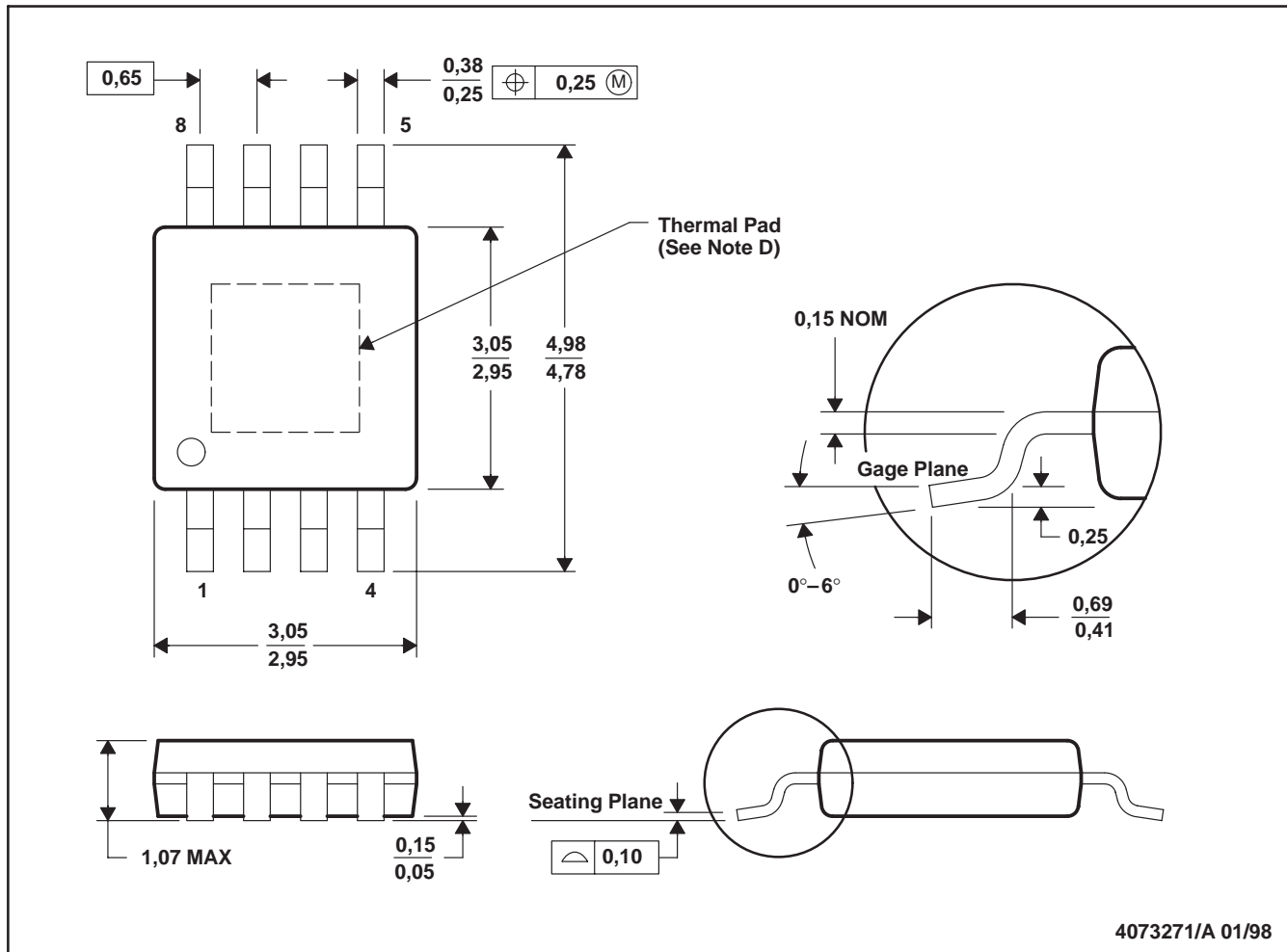

- NOTES:
- A. All linear dimensions are in millimeters.
  - B. This drawing is subject to change without notice.
  - C. Body dimensions include mold flash or protrusions.
  - D. The package thermal performance may be enhanced by attaching an external heat sink to the thermal pad. This pad is electrically and thermally connected to the backside of the die and possibly selected leads.
  - E. Falls within JEDEC MO-187

PowerPAD is a trademark of Texas Instruments Incorporated.



POST OFFICE BOX 655303 • DALLAS, TEXAS 75265

# SN55LVDS31, SN65LVDS31, SN65LVDS3487, SN65LVDS9638 HIGH-SPEED DIFFERENTIAL LINE DRIVERS

SLLS261D – JULY 1997 – REVISED DECEMBER 1998

## MECHANICAL INFORMATION

FK (S-CQCC-N\*\*)

LEADLESS CERAMIC CHIP CARRIER

28 TERMINAL SHOWN

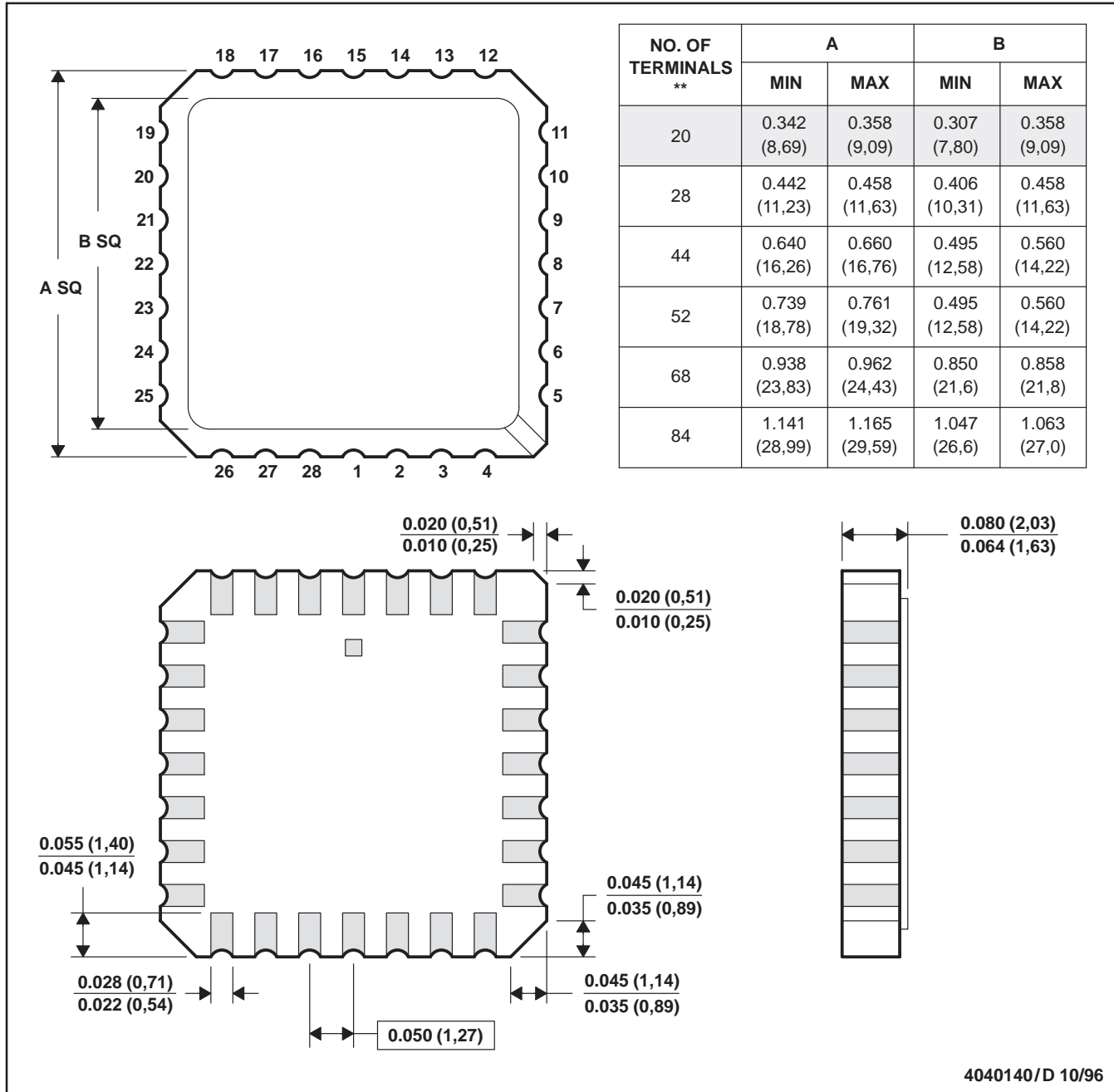

- NOTES: A. All linear dimensions are in inches (millimeters).  
 B. This drawing is subject to change without notice.  
 C. This package can be hermetically sealed with a metal lid.  
 D. The terminals are gold plated.  
 E. Falls within JEDEC MS-004



# SN55LVDS31, SN65LVDS31, SN65LVDS3487, SN65LVDS9638 HIGH-SPEED DIFFERENTIAL LINE DRIVERS

SLLS261D – JULY 1997 – REVISED DECEMBER 1998

## MECHANICAL INFORMATION

J (R-GDIP-T\*\*)

CERAMIC DUAL-IN-LINE PACKAGE

14 PIN SHOWN

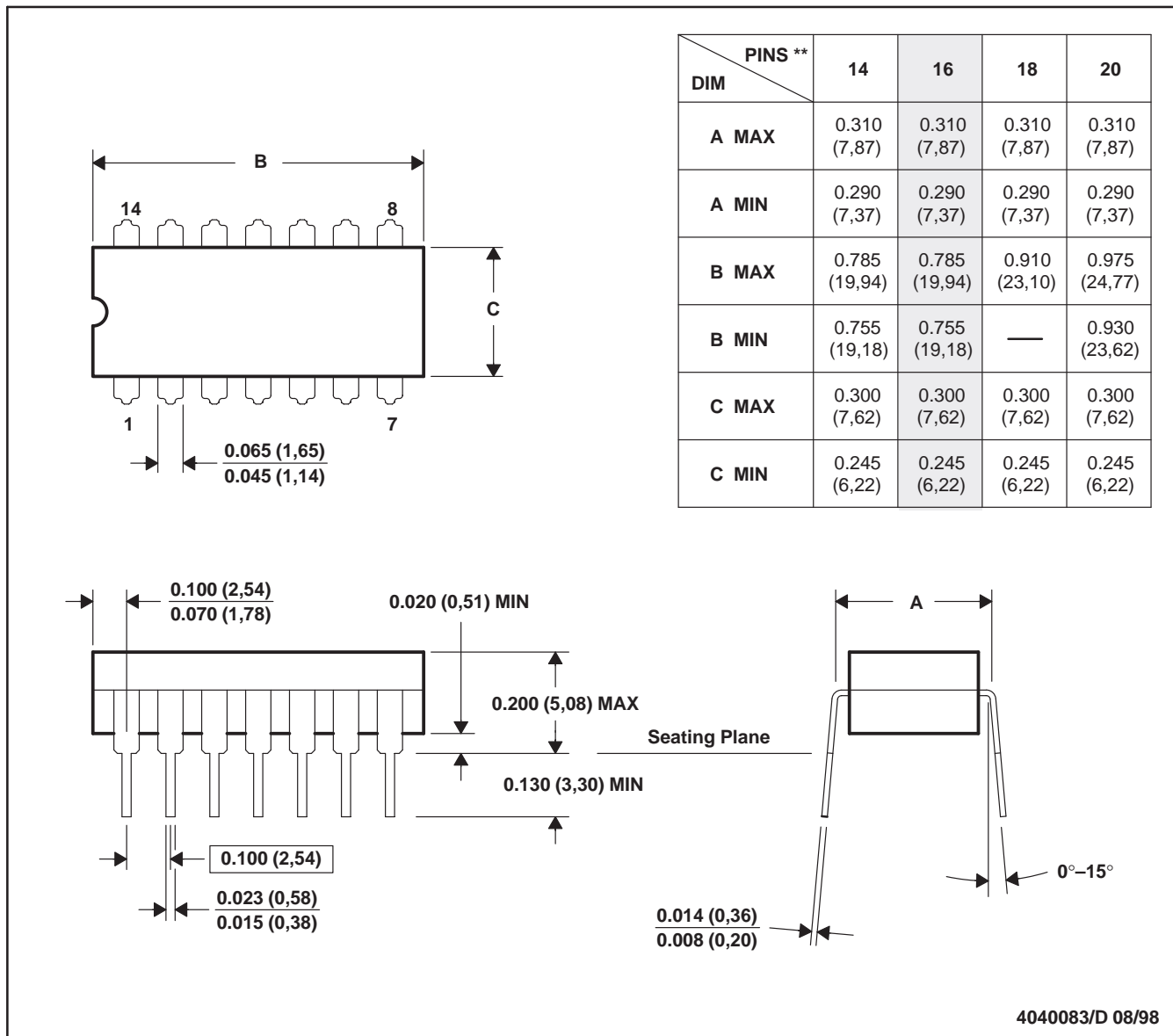

- NOTES:
- A. All linear dimensions are in inches (millimeters).
  - B. This drawing is subject to change without notice.
  - C. This package can be hermetically sealed with a ceramic lid using glass frit.
  - D. Index point is provided on cap for terminal identification only on press ceramic glass frit seal only.
  - E. Falls within MIL STD 1835 GDIP1-T14, GDIP1-T16, GDIP1-T18, GDIP1-T20, and GDIP1-T22.

# SN55LVDS31, SN65LVDS31, SN65LVDS3487, SN65LVDS9638 HIGH-SPEED DIFFERENTIAL LINE DRIVERS

SLLS261D – JULY 1997 – REVISED DECEMBER 1998

## MECHANICAL INFORMATION

W (R-GDFP-F16)

CERAMIC DUAL FLATPACK

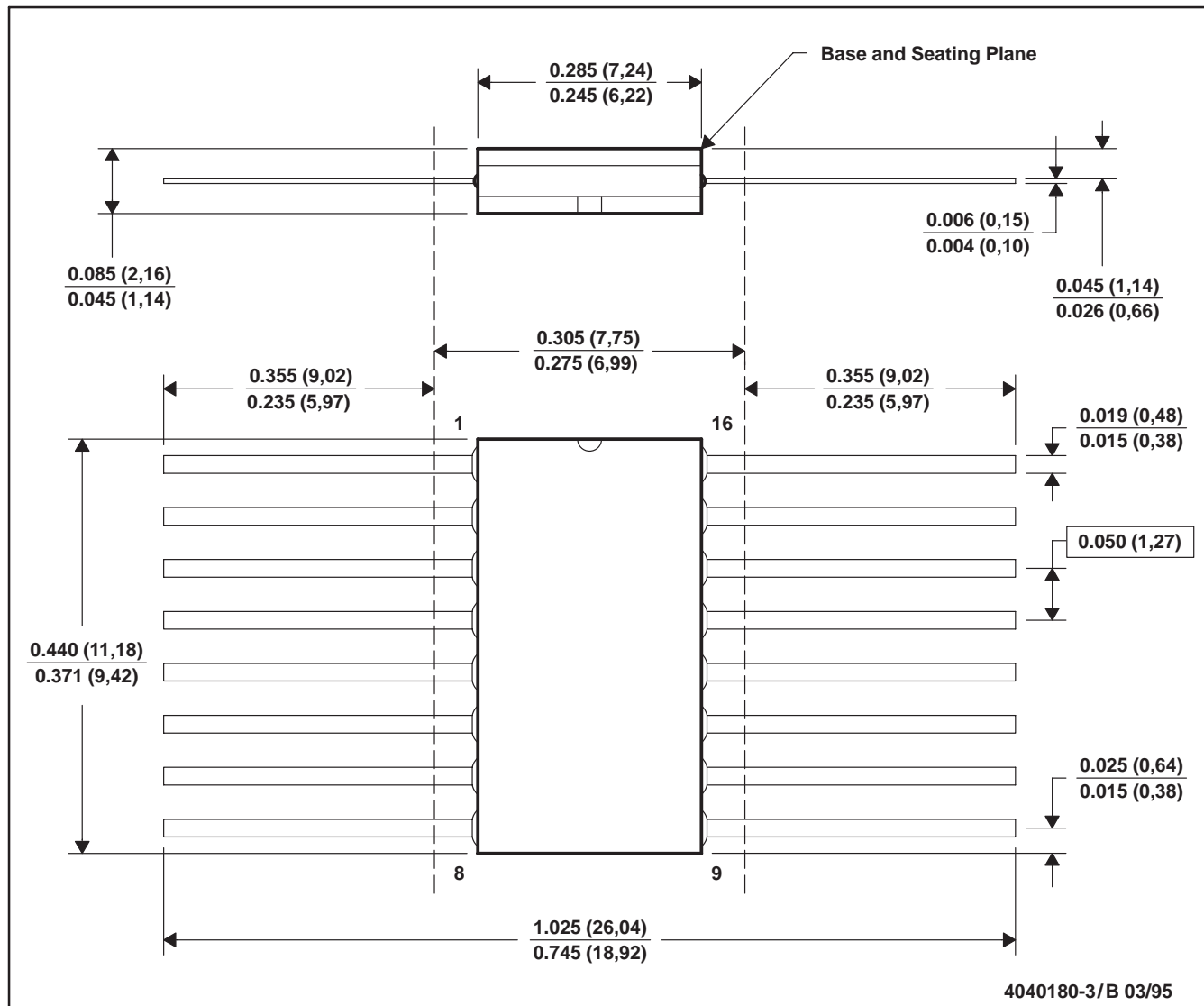

- NOTES: A. All linear dimensions are in inches (millimeters).  
 B. This drawing is subject to change without notice.  
 C. This package can be hermetically sealed with a ceramic lid using glass frit.  
 D. Index point is provided on cap for terminal identification only.  
 E. Falls within MIL-STD-1835 GDFP1-F16 and JEDEC MO-092AC

## IMPORTANT NOTICE

Texas Instruments and its subsidiaries (TI) reserve the right to make changes to their products or to discontinue any product or service without notice, and advise customers to obtain the latest version of relevant information to verify, before placing orders, that information being relied on is current and complete. All products are sold subject to the terms and conditions of sale supplied at the time of order acknowledgement, including those pertaining to warranty, patent infringement, and limitation of liability.

TI warrants performance of its semiconductor products to the specifications applicable at the time of sale in accordance with TI's standard warranty. Testing and other quality control techniques are utilized to the extent TI deems necessary to support this warranty. Specific testing of all parameters of each device is not necessarily performed, except those mandated by government requirements.

CERTAIN APPLICATIONS USING SEMICONDUCTOR PRODUCTS MAY INVOLVE POTENTIAL RISKS OF DEATH, PERSONAL INJURY, OR SEVERE PROPERTY OR ENVIRONMENTAL DAMAGE ("CRITICAL APPLICATIONS"). TI SEMICONDUCTOR PRODUCTS ARE NOT DESIGNED, AUTHORIZED, OR WARRANTED TO BE SUITABLE FOR USE IN LIFE-SUPPORT DEVICES OR SYSTEMS OR OTHER CRITICAL APPLICATIONS. INCLUSION OF TI PRODUCTS IN SUCH APPLICATIONS IS UNDERSTOOD TO BE FULLY AT THE CUSTOMER'S RISK.

In order to minimize risks associated with the customer's applications, adequate design and operating safeguards must be provided by the customer to minimize inherent or procedural hazards.

TI assumes no liability for applications assistance or customer product design. TI does not warrant or represent that any license, either express or implied, is granted under any patent right, copyright, mask work right, or other intellectual property right of TI covering or relating to any combination, machine, or process in which such semiconductor products or services might be or are used. TI's publication of information regarding any third party's products or services does not constitute TI's approval, warranty or endorsement thereof.