

- IEEE Standard for a 1394-1995 Compliant
- IEEE Standard for a 1212-1991 Compliant
- Supports IEEE 1394-1995 Link Layer Control
- PCI Local Bus Specification Rev. 2.1 Compliant
- Supports IEEE 1394 Transfer Rates of 100, 200, and 400 Mb per second
- 3.3-V Core Logic while Maintaining 5-V Tolerant Inputs
- Performs the Function of 1394 Cycle Master
- Provides 4K Bytes of Configurable FIFO RAM
- Provides 5 Scatter-Gather DMA Channels
- Provides Software Control of Interrupt Events
- Provides 4 General-Purpose Input/Outputs
- Supports Plug-and-Play (PnP) Specification
- Generates 32-bit CRC for Transmission of 1394 Packets
- Performs 32-bit CRC Checking on Reception of 1394 Packets
- Provides PCI Bus Master Function for Supporting DMA Operations
- Provides PCI Slave Function for Read/Write Access of Internal Registers
- Supports Distributed DMA Transfers Between 1394 and Local Bus RAM, ROM, AUX, or Zoomed Video
- Advanced Submicron, Low-Power CMOS Technology
- Packaged in a 176-Pin PQFP (PGF)

Table of Contents	
Description	2
Terminal Assignment	3
Signal Name/Terminal Number Sort Tables	4
Terminal Functions	5
System Block Diagram	9
Functional Block Diagram	10
Absolute Maximum Ratings	11
Recommended Operating Conditions	11
Electrical Characteristics	12
PCI Interface Switching Characteristics	13
Parameter Measurement Information	15
Power Supply Sequencing	20
Mechanical Data	21



Please be aware that an important notice concerning availability, standard warranty, and use in critical applications of Texas Instruments semiconductor products and disclaimers thereto appears at the end of this data sheet.

PRODUCTION DATA information is current as of publication date. Products conform to specifications per the terms of Texas Instruments standard warranty. Production processing does not necessarily include testing of all parameters.



POST OFFICE BOX 655303 • DALLAS, TEXAS 75265

Copyright © 1998, Texas Instruments Incorporated

TSB12LV21B (PCILynx-2) IEEE 1394 LINK LAYER CONTROLLER

SLLS306–JULY 1998

description

The TSB12LV21B (PCILynx-2) provides a high-performance IEEE 1394-1995 interface with the capability to transfer data between the 1394 PHY-link interface, the PCI bus interface, and external devices connected to the local bus interface. The 1394 PHY-link interface provides the connection to the 1394 physical layer device; it is supported by the on-board link layer controller (LLC). The LLC provides the control for transmitting and receiving 1394 packet data between the FIFO and PHY-link interface at rates of 100 Mbit/s, 200 Mbit/s, and 400 Mbit/s. The link layer also provides the capability to receive status from the physical layer device and to access the physical layer control and status registers by the application software. The PCILynx-2 complies with

- PCI Local Bus Specification, Revision 2.1
- IEEE Standard for a 1394-1995 High Performance Serial Bus
- IEEE Standard 1212-1991
- IEEE Standard Control and Status Register (CSR) Architecture for Microcomputer Buses

An internal 4Kbyte-memory can be configured as multiple variable-size FIFOs, eliminating the need for external FIFOs. Separate FIFOs are user configurable to support 1394 receive, asynchronous transmit, and asynchronous transmit transfer operations.

The PCI interface supports 32-bit burst transfers up to 33 MHz and is capable of operating both as a master and as a target device. Configuration registers can be loaded from an external serial EEPROM, allowing board and system designers to assign their own unique identification codes. An autoboot mode allows data-moving systems (such as docking stations) to be designed to operate on the PCI bus without the need for a host CPU.

The DMA controller uses packet control list (PCL) data structures to control the transfer of data and allow the DMA to operate without host CPU intervention. These PCLs can reside in PCI memory or in memory that is connected to a local bus port. The PCLs implement an instruction set that allows linking, conditional branching, 1394 data transfer control, auxiliary support commands, and status reporting. Five DMA channels accommodate programmable data types. PCLs can be chained together to form a channel control program that can be developed to support each DMA channel. Data can be stored in either big endian or little endian format, eliminating the need for the host CPU to perform byte swapping. Data can be transferred either to 4-byte aligned locations, to provide the highest performance, or to nonaligned locations, to provide the best memory use.

The RAM, ROM, AUX, ZV, and general purpose I/O (GPIO) ports collectively make up the local bus interface. These ports mapped into the PCI address, can be accessed either through the PCI bus or through internal DMA transactions. Internal transactions do not appear on the external PCI bus, thereby conserving PCI bandwidth. DMA packet control lists or other data may be stored in external RAM or ROM attached to the local bus interface. This further reduces PCI bus use and generally improves performance. The ZV local bus port is designed to transfer data from 1394 video devices to an external device connected to the PCILynx-2 ZV port. This interface provides a method for receiving 1394 digital camera packets directly from a ZV-compliant device attached to the local bus interface.

Built-in test registers, a dedicated test output terminal, and four GPIO terminals allow observation of internal states and provide a convenient software debug capability. Programmable interrupts are available to inform driver software of important events, such as 1394 bus resets and DMA-to-PCL transfer completion.

The 3.3-V internal operation provides reduced power consumption, while maintaining compatibility with 5-V signaling environments. The PCI interface is compatible with both 3-V and 5-V PCI systems.



POST OFFICE BOX 655303 • DALLAS, TEXAS 75265

terminal assignment

PGF QUAD FLATPACK PACKAGE

TOP VIEW

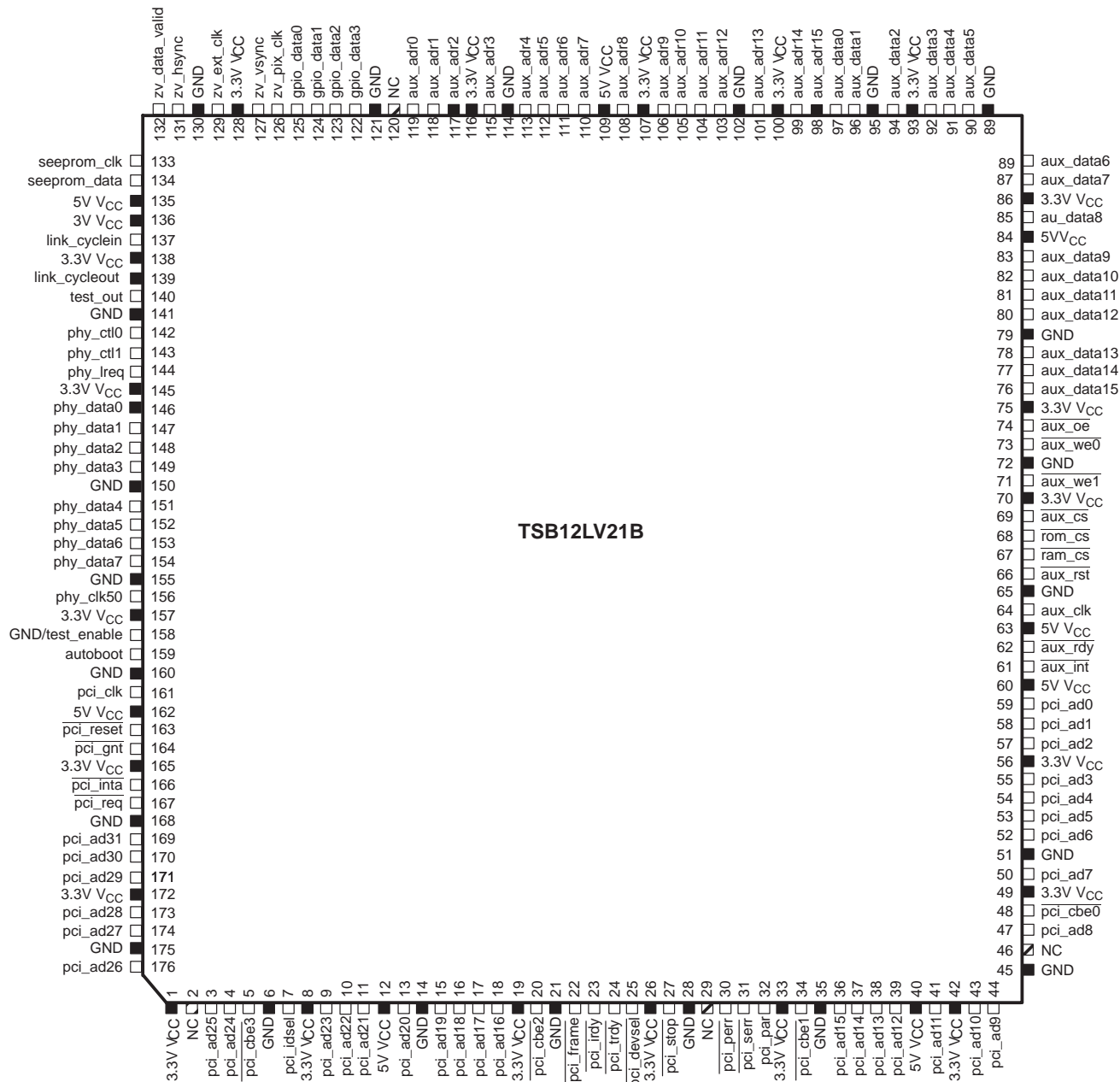

Figure 1. PCILynx-2 Terminal Assignment/Pinout

TSB12LV21B (PCILynx-2) IEEE 1394 LINK LAYER CONTROLLER

SLLS306–JULY 1998

pin description table

This sections identifies and classifies the functionality of each pin on the PCILynx–2.

Table 1. Signals Sorted by Pin Number

PIN NO.	SIGNAL NAME	PIN NO.	SIGNAL NAME	PIN NO.	SIGNAL NAME	PIN NO.	SIGNAL NAME
1	3.3V V _{CC}	42	3.3V V _{CC}	83	aux_data9	124	gpio_data1
2	NC	43	pci_ad10	84	5.0V V _{CC}	125	gpio_data0
3	pci_ad25	44	pci_ad9	85	aux_data8	126	zp_pix_clk
4	pci_ad24	45	GND	86	3.3V V _{CC}	127	zv_vsync
5	pci_cbe3	46	NC	87	aux_data7	128	3.3V V _{CC}
6	GND	47	pci_ad8	88	aux_data6	129	zv_ext_clk
7	pci_idsel	48	pci_cbe0	89	GND	130	GND
8	3.3V V _{CC}	49	3.3V V _{CC}	90	aux_data5	131	zv_hsync
9	pci_ad23	50	pci_ad7	91	aux_data4	132	zv_data_valid
10	pci_ad22	51	GND	92	aux_data3	133	seeprom_clk
11	pci_ad21	52	pci_ad6	93	3.3V V _{CC}	134	seeprom_data
12	5.0V V _{CC}	53	pci_ad5	94	aux_data2	135	5V V _{CC}
13	pci_ad20	54	pci_ad4	95	GND	136	3V V _{CC}
14	GND	55	pci_ad3	96	aux_data1	137	link_cyclein
15	pci_ad19	56	3.3V V _{CC}	97	aux_data0	138	3.3V V _{CC}
16	pci_ad18	57	pci_ad2	98	aux_adr15	139	link_cylceout
17	pci_ad17	58	pci_ad1	99	aux_adr14	140	test_out
18	pci_ad16	59	pci_ad0	100	3.3V V _{CC}	141	GND
19	3.3V V _{CC}	60	5.0V V _{CC}	101	aux_adr13	142	phy_ctl0
20	pci_cbe2	61	aux_int	102	GND	143	phy_ctl1
21	GND	62	aux_rdy	103	aux_adr12	144	phy_lreq
22	pci_frame	63	5.0V V _{CC}	104	aux_adr11	145	3.3V V _{CC}
23	pci_irdy	64	aux_clk	105	aux_adr10	146	phy_data0
24	pci_trdy	65	GND	106	aux_adr9	147	phy_data1
25	pci_devsel	66	aux_rst	107	3.3V V _{CC}	148	phy_data2
26	3.3V V _{CC}	67	ram_cs	108	aux_adr8	149	phy_data3
27	pci_stop	68	rom_cs	109	5.0V V _{CC}	150	GND
28	GND	69	aux_cs	110	aux_adr7	151	phy_data4
29	NC	70	3.3V V _{CC}	111	aux_adr6	152	phy_data5
30	pci_perr	71	aux_we1	112	aux_adr5	153	phy_data6
31	pci_serr	72	GND	113	aux_adr4	154	phy_data7
32	pci_par	73	aux_we0	114	GND	155	GND
33	3.3V V _{CC}	74	aux_oe	115	aux_adr3	156	phy_clk50
34	pci_cbe1	75	3.3V V _{CC}	116	3.3V V _{CC}	157	3.3V V _{CC}
35	GND	76	aux_data15	117	aux_adr2	158	test_out/GND
36	pci_ad15	77	aux_data14	118	aux_adr1	159	auto_boot
37	pci_ad14	78	aux_data13	119	aux_adr0	160	GND
38	pci_ad13	79	GND	120	NC	161	pci_clk
39	pci_ad12	80	aux_data12	121	GND	162	5.0V V _{CC}
40	5.0V V _{CC}	81	aux_data11	122	gpio_data3	163	pci_reset
41	pci_ad11	82	aux_data10	123	gpio_data2	164	pci_gnt



Table 1. Signals Sorted by Pin Number (Continued)

PIN NO.	SIGNAL NAME	PIN NO.	SIGNAL NAME	PIN NO.	SIGNAL NAME	PIN NO.	SIGNAL NAME
165	3.3V V _{CC}	168	GND	171	pci_ad29	174	pci_ad27
166	pci_inta	169	pci_ad31	172	3.3V V _{CC}	175	GND
167	pci_req	170	pci_ad30	173	pci_ad28	176	pci_ad26

Terminal Functions

power supply terminals

TERMINAL NAME	TERMINAL NO.	I/O TYPE	FUNCTION
GND	6, 14, 21, 28, 35, 45, 51, 65, 72, 79, 89, 95, 102, 114, 121, 130, 141, 150, 155, 160, 168, 175	I	Device ground terminals
3.3V V _{CC}	1, 8, 19, 26, 33, 42, 49, 56, 70, 75, 86, 93, 100, 107, 116, 128, 136, 138, 145, 157, 165, 172	I	3.3-V power supply terminal for core logic
5.0V V _{CC}	12, 40, 60, 63, 84, 109, 162	I	5-V power rail for 5-V tolerant Input buffers

PCI system terminals

TERMINAL NAME	TERMINAL NO.	I/O TYPE	FUNCTION
pci_clk	161	I	System PCI bus clock. This signal ranges from 0MHz–33MHz and provides timing for all transactions on the PCI bus. All PCI signals are sampled at the rising edge of PCLK.
pci_reset	163	I	pci_reset. When the PCI bus reset is asserted the pci_reset signal causes the PCILynx-2 to 3-state all output buffers and reset all internal registers. When pci_reset is asserted, the device is completely nonfunctional. After pci_reset is deasserted, the PCILynx-2 is in its default state.
pci_inta	166	OD	PCI system interrupt A. This is an open drain signal.

TSB12LV21B (PCILynx-2) IEEE 1394 LINK LAYER CONTROLLER

SLLS306–JULY 1998

Terminal Functions (Continued)

PCI address and data terminals

TERMINAL NAME	NO.	I/O TYPE	FUNCTION
pci_ad31 – pci_ad29	169 – 171	I/O	Multiplexed PCI address and data signals. During the address phase of a primary bus PCI cycle, pci_ad31:0 contain a 32-bit address or other destination information. During the data phase pci_ad31:0 contain data
pci_ad28	173		
pci_ad27	174		
pci_ad26	176		
pci_ad25	3		
pci_ad24	4		
pci_ad23 – pci_ad21	9 – 11		
pci_ad20	13		
pci_ad19 – pci_ad16	15 – 18		
pci_ad15 – pci_ad12	36 – 39		
pci_ad11	41		
pci_ad10	43		
pci_ad9	44		
pci_ad8	47		
pci_ad7	50		
pci_ad6 – pci_ad3	52 – 55		
pci_ad2 – pci_ad0	57 – 59		
pci_cbe3	5	I/O	PCI Command/Byte enables
pci_cbe2	20		
pci_cbe1	34		
pci_cbe0	48		
pci_par	32	I/O	PCI bus parity. In all PCI bus read and write cycles the PCILynx-2 calculates even parity across the pci_ad31:0 and pci_cbe3:0 signals. As an initiator during PCI cycles, the PCILynx-2 outputs this parity indicator with a one pci_clk delay. As a target during PCI cycles, the calculated parity is compared to the initiator's parity indicator. A miscompare can result in the assertion of a parity error (pci_perr).



Terminal Functions (Continued)

PCI interface control

TERMINAL NAME	NO.	I/O TYPE	FUNCTION
<u>pci_devsel</u>	24	I/O	PCI device select. The PCILynx-2 asserts this signal to claim a PCI cycle as the target device. As a PCI initiator on the bus, the PCILynx-2 monitors this signal until a target responds. If no target responds before time-out occurs, then the PCILynx-2 will terminate the cycle with an initiator abort.
<u>pci_frame</u>	22	I/O	PCI cycle frame. This signal is driven by the initiator of a bus cycle. <u>pci_frame</u> is asserted to indicate that a bus transaction is beginning, and data transfers continue while this signal is asserted. When <u>pci_frame</u> is deasserted the PCI bus transaction is in the final data phase.
<u>pci_gnt</u>	164	I	PCI bus grant. This signal is driven by the PCI bus arbiter to grant the PCILynx-2 access to the PCI bus after the current data transaction has completed. This signal may or may not follow a PCI bus request depending upon the PCI bus parking algorithm.
<u>pci_idsel</u>	7	I	Initialization device select. <u>pci_idsel</u> selects the PCILynx-2 during configuration space accesses. <u>pci_idsel</u> can be connected to one of the upper 24 PCI address lines on the PCI bus.
<u>pci_irdy</u>	23	I/O	PCI initiator ready. <u>pci_irdy</u> indicates the PCI bus initiator's ability to complete the <u>current data phase</u> of the transaction. A <u>data phase is completed</u> upon a rising edge of <u>pci_clk</u> where both <u>pci_irdy</u> and <u>pci_trdy</u> are asserted. Until <u>pci_irdy</u> and <u>pci_trdy</u> are both sampled asserted, wait states are inserted.
<u>pci_perr</u>	30	I/O	PCI parity error indicator. This signal is driven by a PCI device to indicate that calculated parity does not match <u>pci_par</u> , when <u>pci_perr</u> is enabled through bit 6 of the command register.
<u>pci_req</u>	167	O	PCI bus request. Asserted by the PCILynx-2 to request access to the PCI bus as an initiator.
<u>pci_serr</u>	31	OD	PCI system error. Output that is pulsed from the PCILynx-2 when enabled through the command register, indicating a system error has occurred. The PCILynx-2 needs not be the target of the PCI cycle in order to assert this signal.
<u>pci_stop</u>	27	I/O	PCI cycle stop signal. This signal is driven by a PCI target to request the initiator to stop the current PCI bus transaction. This signal is used for target disconnects and is commonly asserted by target devices which do not support burst data transfers.
<u>pci_trdy</u>	24	I/O	PCI target ready. <u>pci_trdy</u> indicates the primary bus target's ability to complete the <u>current data phase</u> of the transaction. A <u>data phase is completed</u> upon a rising edge of <u>pci_clk</u> where both <u>pci_irdy</u> and <u>pci_trdy</u> are asserted. Until both <u>pci_irdy</u> and <u>pci_trdy</u> are asserted, wait states are inserted.

IEEE 1394 PHY/LINK interface terminals

TERMINAL NAME	NO.	I/O TYPE	FUNCTION
<u>phy_ctl1</u> <u>phy_ctl0</u>	143 142	I/O	PHY-link bidirectional control lines
<u>phy_data7 – phy_data4</u> <u>phy_data3 – phy_data0</u>	154 – 151 149 – 146	I/O	PHY-link bidirectional data lines
<u>phy_clk50</u>	156	I	50MHz-System clock from PHY chip
<u>phy_lreq</u>	144	O	PHY-link request signal generated by the PCILynx-2 controller

TSB12LV21B (PCILynx-2) IEEE 1394 LINK LAYER CONTROLLER

SLLS306–JULY 1998

Terminal Functions (Continued)

Auxiliary/Zoom Video Port terminals

TERMINAL NAME	NO.	I/O TYPE	FUNCTION
aux_clk	64	O	Auxiliary port clock out. This signal is output at the frequency of the PCI clock.
aux_rst	66	O	Auxiliary port reset out
aux_int	61	I	Auxiliary port interrupt input
aux_adr15 – aux_adr14 aux_adr13 aux_adr12 – aux_adr9 aux_adr8 aux_adr7 – aux_adr4 aux_adr3 aux_adr2 – aux_adr0	98 – 99 101 103 – 106 108 110 – 113 115 117 – 119	O	Auxiliary port address lines output to external logic
aux_data15 – aux_data13 aux_data12 – aux_data9 aux_data8 aux_data7 – aux_data6 aux_data5 – aux_data3 aux_data2 aux_data1 – aux_data0	76 – 78 80 – 83 85 87 – 88 90 – 92 94 96 – 97	I/O	Auxiliary port bidirectional data bus to external logic
aux_cs	69	O	Auxiliary port chip select to external logic
aux_oe	74	O	Auxiliary port output enable to enable external logic data onto the auxiliary data bus
aux_rdy	62	I	Auxiliary port ready indication from external logic
aux_we1 aux_we0	71 73	O	Auxiliary port write strobes to external logic
ram_cs	67	O	External RAM chip select
rom_cs	68	O	External ROM chip select
zv_data_valid	132	O	Zoom video port data valid signal
zv_ext_clk	129	I	Zoom video port external clock input
zv_hsync	131	O	Zoom video port horizontal sync signal
zv_pix_clk	126	I/O	Zoom video port pixel clock for zoomed video data
zv_vsync	127	O	Zoom video port vertical sync signal

miscellaneous

TERMINAL NAME	NO.	I/O TYPE	FUNCTION
autoboot	159	I	Autoboot. Selects autoboot mode. When this terminal is tied high, autoboot mode is selected.
gpio_data3 – gpio_data2	122 – 125	I/O	Auxiliary port general-purpose programmable I/O signals
link_cyclein	137	I	Optional 8kHz clock for use as the cycle clock
link_cycleout	140	O	Cycle timer 8kHz clock output
seeprom_clk	133	I/O	External serial EEPROM data clock
seeprom_data	134	I/O	External serial EEPROM read/write data line
test_enable/GND	158	I	Enables TEST_OUT for AND tree testing. This pin should be tied to GND if AND tree testing is not used.
test_out	140	O	Output for AND tree testing



system block diagram

The following figure illustrates a typical system implementation of the PCILynx-2.

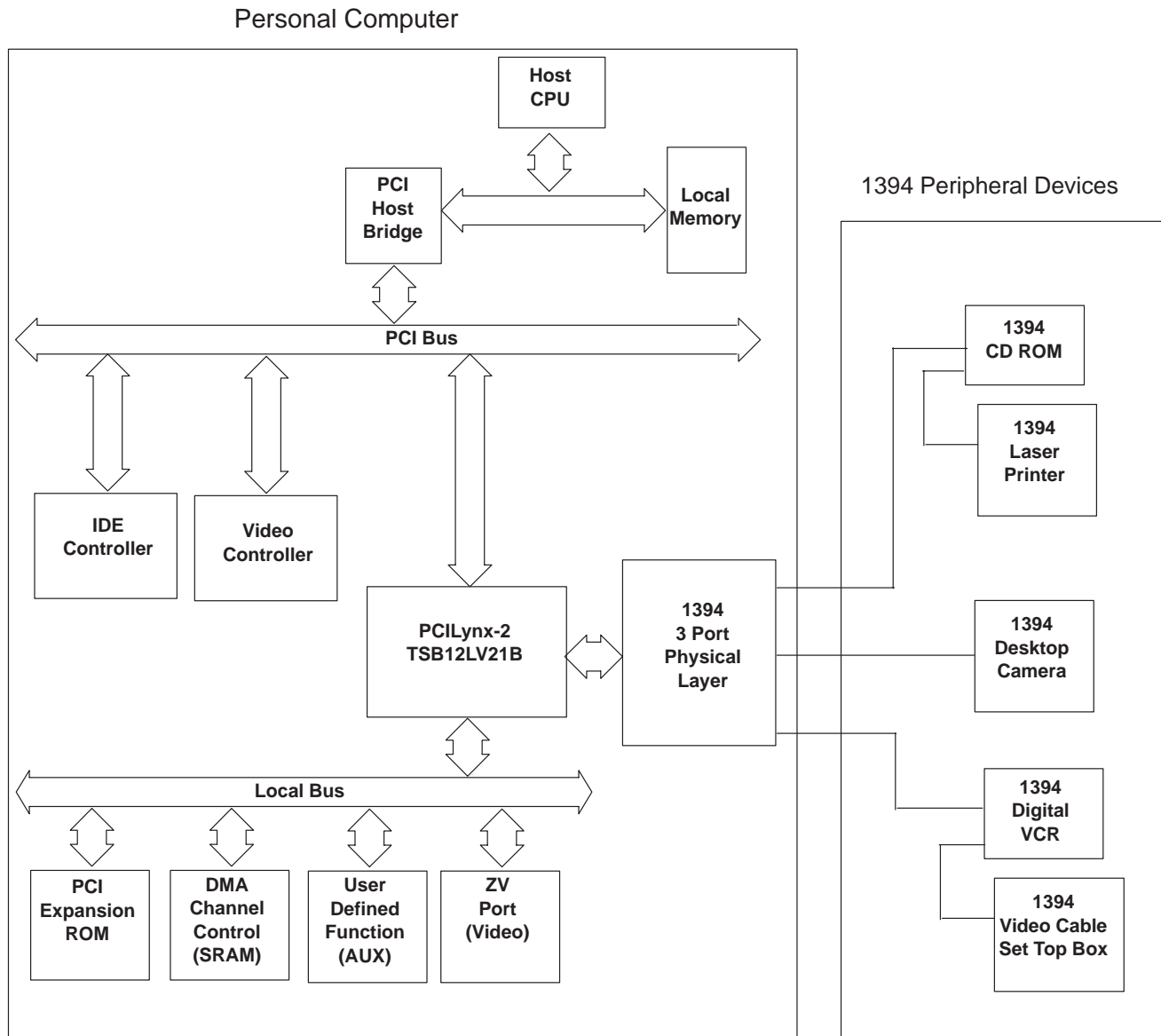

Figure 2. System Block Diagram

TSB12LV21B (PCIlynx-2) IEEE 1394 LINK LAYER CONTROLLER

SLLS306–JULY 1998

functional block diagram

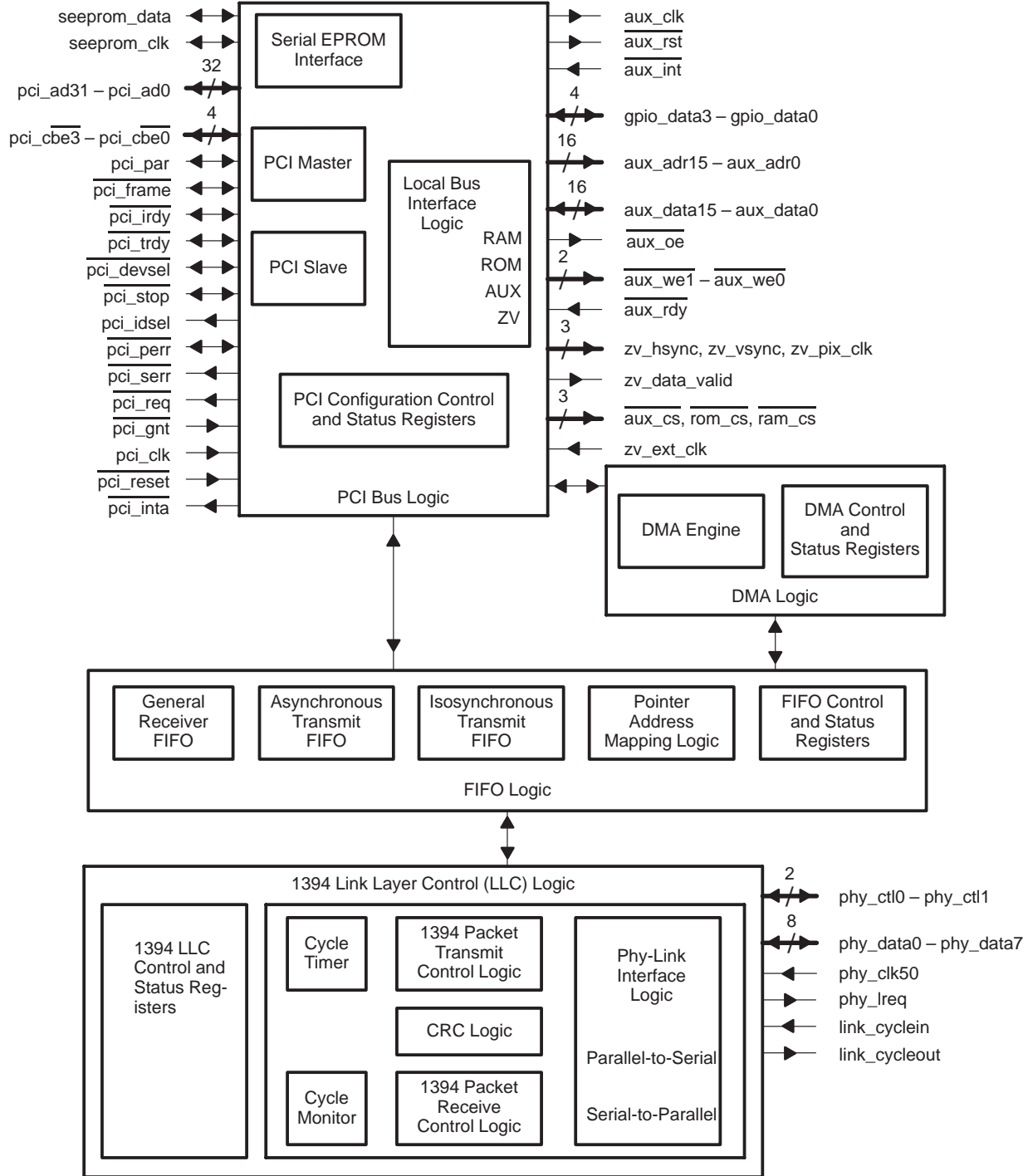

Figure 3. Functional Block Diagram

absolute maximum ratings over operating temperature ranges (unless otherwise noted)†

Supply voltage range, V_{CC}	–0.5 V to 4 V
V_{CCP}	–0.5 V to 6 V
V_{CC5V}	–0.5 V to 6 V
Input voltage range for Universal PCI, V_I : PCI	–0.5 V to $V_{CCP} + 0.5$ V
Input voltage range for 5-V tolerant TTL/LVCMOS, V_I :	–0.5 V to $V_{CC5V} + 0.5$ V
Output voltage range for Universal PCI, V_O	–0.5 V to $V_{CCP} + 0.5$ V
Output voltage range for 5-V tolerant TTL/LVCMOS, V_O	–0.5 V to $V_{CC5V} + 0.5$ V
Input clamp current, I_{IK} ($V_I < 0$ or $V_I > V_{CC}$) (see Note 2)	± 20 mA
Output clamp current, I_{OK} ($V_O < 0$ or $V_O > V_{CC}$) (see Note 3)	± 20 mA

† Stresses beyond those listed under “absolute maximum ratings” may cause permanent damage to the device. These are stress ratings only, and functional operation of the device at these or any other conditions beyond those indicated under “recommended operating conditions” is not implied. Exposure to absolute-maximum-rated conditions for extended periods may affect device reliability.

- NOTES: 1. Applies to external input and bidirectional buffers. For 5-V tolerant buffers, use $V_I > V_{CC5V}$. For Universal PCI, use $V_I > V_{CCP}$.
2. Applies to external output and bidirectional buffers. For 5-V tolerant buffers, use $V_O > V_{CC5V}$. For Universal PCI, use $V_O > V_{CCP}$.

recommended operating conditions (see Note 4)

		OPERATION	MIN	NOM	MAX	UNIT
Core voltage, V_{CC}	Commercial	3.3	3	3.3	3.6	V
I/O voltage, V_{CCP}	Commercial	5	3	5	5.5	V
I/O voltage, V_{CC5V}	Commercial	5	3	5	5.5	V
High-level Input voltage, $V_{IH}†$			2			V
Low-level Input voltage, $V_{IL}†$					0.8	V
Input voltage, V_I	Universal PCI		0		V_{CCP}	V
	5-V tolerant		0		V_{CC5V}	V
Output voltage, $V_O‡$			0		V_{CC}	V
Input transition times (t_r and t_f), t_t			0		6	ns
Operating ambient temperature range, T_A			0	25	70	°C
Virtual junction temperature, $T_J§$			0	25	115	°C

† Applies for external input and bidirectional buffers without hysteresis.

‡ Applies for external output buffers.

§ These junction temperatures reflect simulation conditions. Customer is responsible for verifying junction temperature.

NOTE 3: Unused or floating pins (input or I/O) must be held high or low.

TSB12LV21B (PCILynx-2) IEEE 1394 LINK LAYER CONTROLLER

SLLS306–JULY 1998

electrical characteristics over recommended operating conditions (unless otherwise noted)

PARAMETER		OPERATION	TEST CONDITIONS	MIN	MAX	UNIT
V _{OH}	High-level output voltage (see Note 5)	PCI	3.3 V	I _{OH} = -0.5 mA	0.9 V _{CC}	V
			5 V	I _{OH} = -2 mA	2.4	
		TTL/LVCMOS†		I _{OH} = -18 mA	2.4	
		TTL/LVCMOS‡		I _{OH} = -14 mA	2.4	
V _{OL}	Low-level output voltage	PCI	3.3 V	I _{OL} = 1.5 mA	0.1 V _{CC}	V
			5 V	I _{OL} = 6 mA	0.5	
		TTL/LVCMOS†		I _{OL} = 18 mA	0.5	
		TTL/LVCMOS‡		I _{OL} = 14 mA	0.5	
I _{IL}	Low-level input current	Input pins	Bushold	V _I = 0.8 V	20	μA
			Others	V _I = GND	-1	
		I/O pins	Bushold	V _I = 0.8 V	400	
			Others	V _I = GND	-20	
I _{IH}	High-level input current	Input pins	Bushold	V _I = 2 V	-20	μA
			Others	V _I = 5.5 V	20	
		I/O pins	Bushold	V _I = 2 V	-20	
			Others	V _I = 5.5 V	20	

† All PHY-link pins, aux_clk(64), aux_we1(71), and aux_we0(73).

‡ All other TTL/LVCMOS pins

NOTE 4: V_{OH} is not tested on pci_serr(31) or pci_inta(166) due to open-drain output.



PCI interface switching characteristics, see Figure 4

PARAMETER	MEASURED	TEST CONDITION	MIN	TYP	MAX	UNIT
t _{su1} Setup time, pci_xx low or high to pci_clk high [†]	40% to 40%		7			ns
t _{h1} Hold time, pci_clk high to pci_xx low or high [†] , pci_gnt low or high	40% to 40%		0			ns
t _{d1} Delay time, pci_clk high to pci_xx low or high [†]	40% to 40%		2		11	ns
t _{su2} Setup time, pci_gnt low or high to pci_clk high	40% to 40%		10			ns
t _{d2} Delay time, pci_clk high to pci_inta low or high	40% to 40%		2		13	ns

[†] In this case, pci_xx refers to the following signals; pci_ad31–0, pci_cbe3–0, pci_par, pci_frame, pci_irdy, pci_trdy, pci_devsel, pci_stop, pci_idsel, pci_perr, pci_serr, pci_req.

phy-link interface switching characteristics, see Figure 5

PARAMETER	MEASURED	TEST CONDITION	MIN	TYP	MAX	UNIT
t _{su3} Setup time, phy_xx low or high to phy_clk high [†]	1.3 V to 1.3 V		4			ns
t _{h2} Hold time, phy_clk high to phy_xx, link_cyclein low or high	1.3 V to 1.3 V		1			ns
t _{d3} Delay time, phy_clk high to phy_xx, phy_lreq low or high [†]	1.3 V to 1.3 V		3		11	ns
t _{su4} Setup time, phy_clk high to link_cyclein low or high	1.3 V to 1.3 V		5			ns
t _{d4} Delay time, phy_clk high to link_cycleout low or high	1.3 V to 1.3 V		3		13	ns

[†] In this case, phy_xx refers to the following bidirectional signals; phy_ctl1–0, phy_data7–0.

local bus switching characteristics, see Figure 6

PARAMETER	MEASURED	TEST CONDITION	MIN	TYP	MAX	UNIT
t _{d5} Delay time, aux_clk high to aux_adr, aux_data15–0 (write), aux_oe valid [†]	1.3 V to 1.3 V		0		15	ns
t _{d6} Delay time, aux_clk high to rom_cs, ram_cs, aux_cs valid	1.3 V to 1.3 V		0		20	ns
t _{d7} Delay time, aux_we0, aux_we1 high (deasserted) to aux_adr, aux_data15–0 (write), aux_oe, rom_cs, ram_cs, aux_cs valid	1.3 V to 1.3 V		0.5			ns
t _{d8} Delay time, aux_clk low to aux_we0, aux_we1 low (asserted)	1.3 V to 1.3 V		0		10	ns
t _{d9} Delay time, aux_clk high to aux_we0, aux_we1 high (deasserted)	1.3 V to 1.3 V		0		10	ns
t _{d10} Delay time, aux_clk high to gpio_data3–0 valid	1.3 V to 1.3 V		2		15	ns
t _{su5} Setup time, aux_adr, adr_data15–0 (write), aux_oe, rom_cs, ram_cs, aux_cs valid before aux_we0, aux_we1 low (asserted)	1.3 V to 1.3 V		5			ns
t _{su6} Setup time, aux_data15–0 (read), aux_rdy, gpio_data3–0 valid before aux_clk high	1.3 V to 1.3 V		10			ns
t _{h3} Hold time, aux_data15–0 (read), aux_rdy, gpio_data3–1 invalid after aux_clk high	1.3 V to 1.3 V		0			ns

[†] These signals are asserted asynchronously when a ZOOM port transfer immediately precedes the local bus transfer. In all cases, the setup time to aux_we1 and aux_we0 and the number of waitstates remain the same.

TSB12LV21B (PCILynx-2) IEEE 1394 LINK LAYER CONTROLLER

SLLS306–JULY 1998

zoom video port switching characteristics, source clock = 30 ns with a 50% duty cycle

PARAMETER		MEASURED	TEST CONDITION	MIN	TYP	MAX	UNIT
t_{su7}	Setup time, zv_hsync low, zv_vsync, zv_data_valid high before zv_pix_clk high	1.3 V to 1.3 V	See Figure 4	12			ns
t_{h4}	Hold time, zv_hsync high, zv_vsync, zv_data_valid low after zv_pix_clk low	1.3 V to 1.3 V	See Figure 4	14			ns
t_{su8}	Setup time, aux_data7–0 valid before zv_pix_clk high or low	1.3 V to 1.3 V	See Figure 4	10			ns
t_{h5}	Hold time, aux_data7–0 valid after zv_pix_clk high or low	1.3 V to 1.3 V	See Figure 4	14			ns
t_{d11}	Delay time, zv_hsync low, zv_vsync, zv_data_valid high after zv_pix_clk low	1.3 V to 1.3 V	See Figure 5	–1		3	ns
t_{d12}	Delay time, aux_data7–0 invalid after zv_pix_clk low	1.3 V to 1.3 V	See Figure 5	–1		5	ns
t_{su9}	Setup time, zv_hsync low before zv_pix_clk high	1.3 V to 1.3 V	See Figure 6	25			ns
t_{h6}	Hold time, zv_hsync high after zv_pix_clk high	1.3 V to 1.3 V	See Figure 6	14			ns
t_{su10}	Setup time, zv_vsync high before zv_pix_clk high	1.3 V to 1.3 V	See Figure 6	10			ns
t_{su11}	Setup time, aux_data7–0 valid, zv_data_valid high before zv_pix_clk high	1.3 V to 1.3 V	See Figure 6	25			ns
t_{h7}	Hold time, aux_data7–0 valid, zv_data-valid low after zv_pix_clk high	1.3 V to 1.3 V	See Figure 6	14			ns



PARAMETER MEASUREMENT INFORMATION

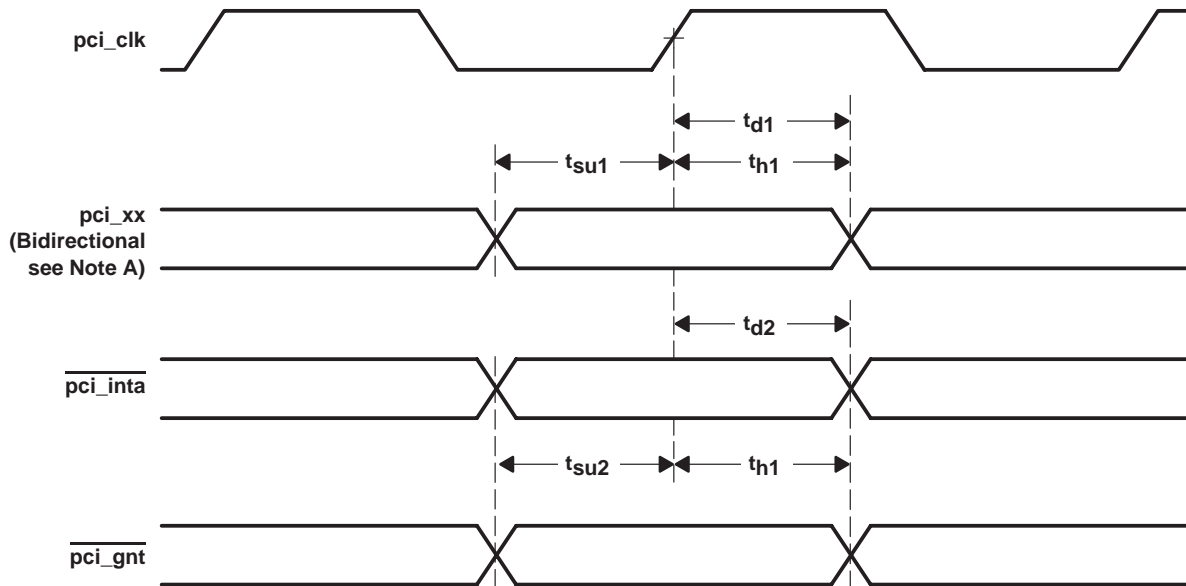

NOTE A: In this case, pci_xx refers to the following bidirectional signals; pci_ad31–0, pci_cbe3–0, pci_par, pci_frame, pci_irdy, pci_trdy, pci_devsel, pci_stop, pci_idsel, pci_perr, pci_serr, pci_req.

Figure 4. PCI Interface Timing Waveforms

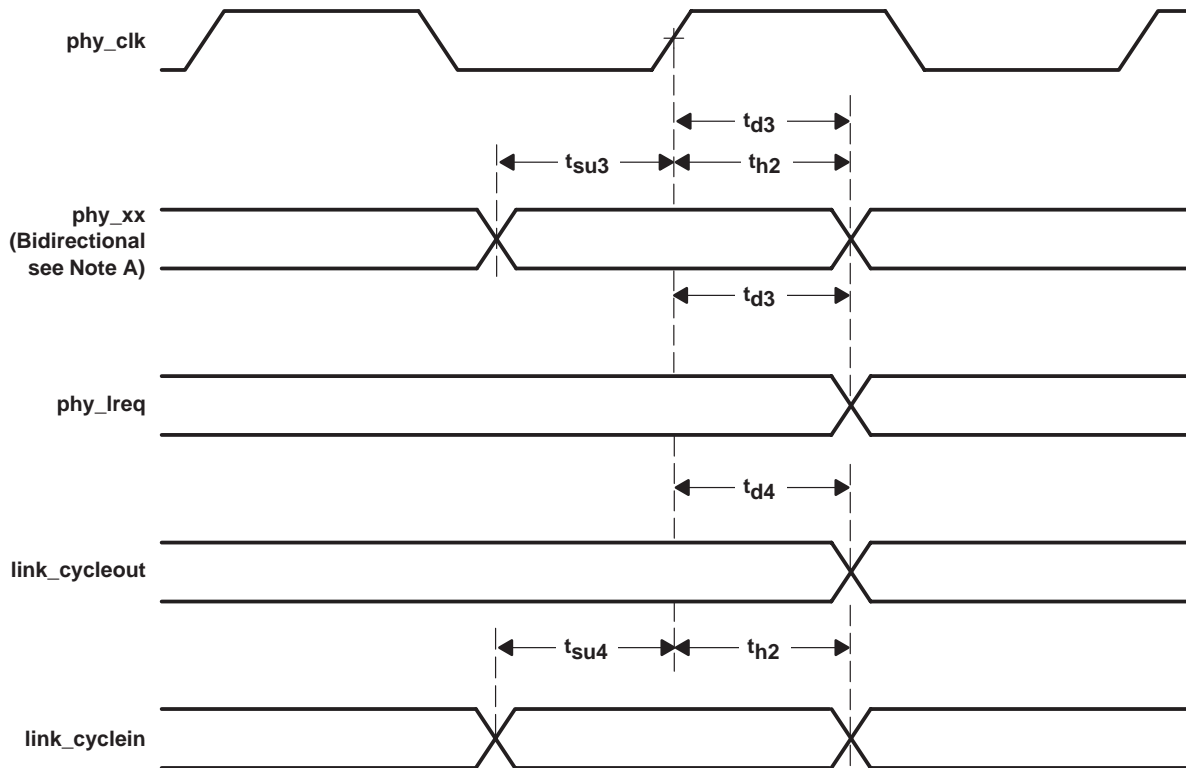

NOTE A: In this case, phy_xx refers to the following bidirectional signals; phy_ctl1–0, phy_data7–0.

Figure 5. Phy-Link Interface Timing Waveforms

TSB12LV21B (PCILynx-2) IEEE 1394 LINK LAYER CONTROLLER

SLLS306–JULY 1998

PARAMETER MEASUREMENT INFORMATION

OUTPUTS

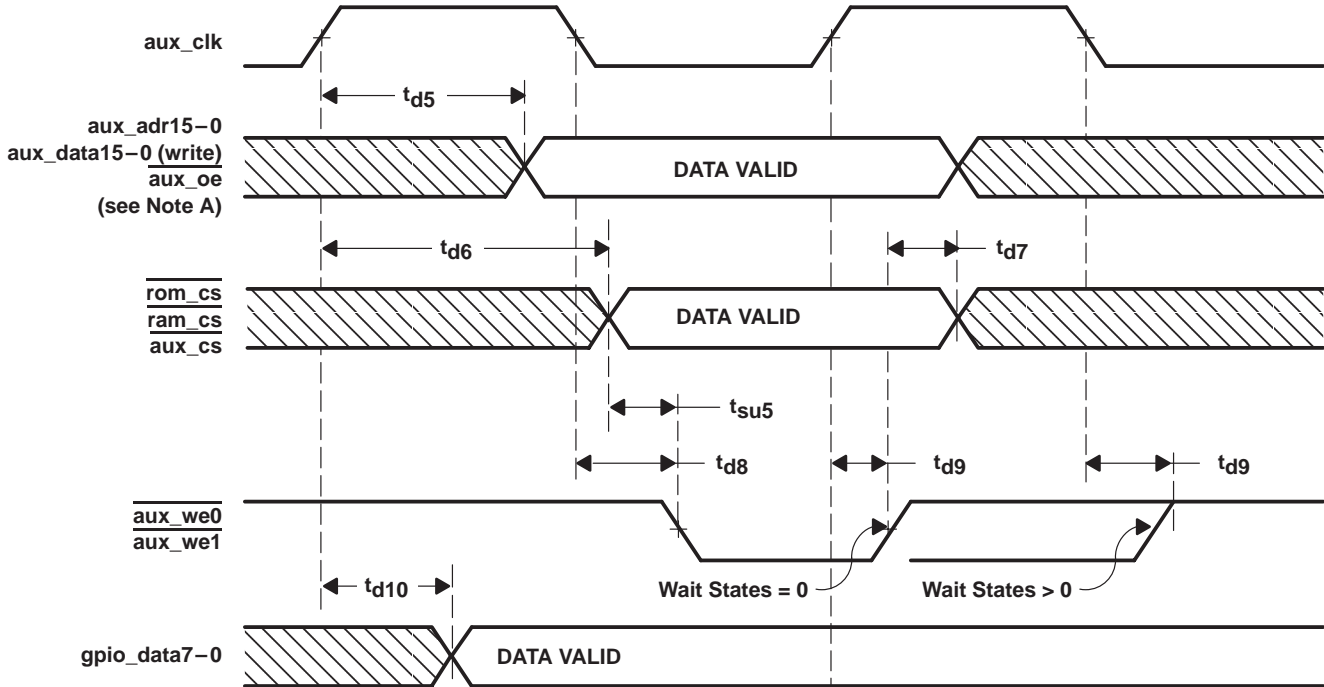

INPUTS

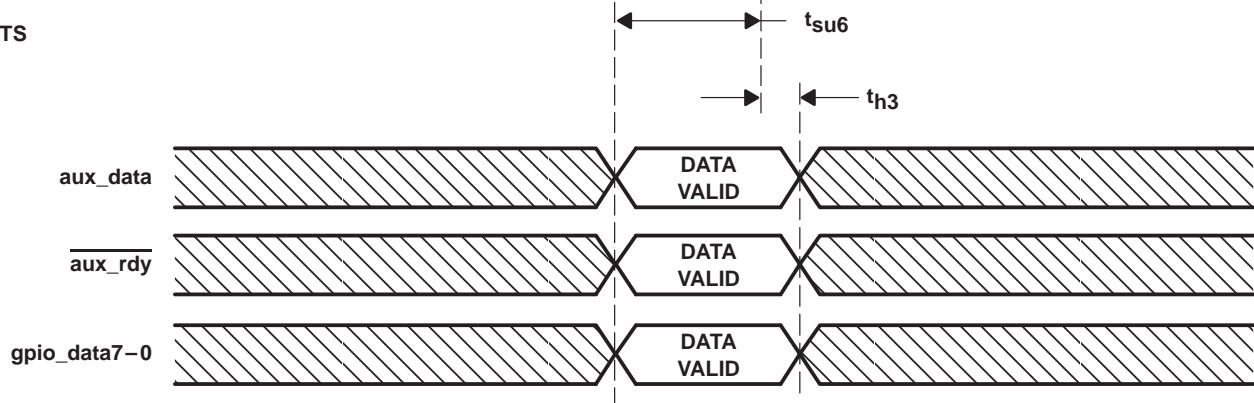

NOTE A: These signals are asserted asynchronously when a ZOOM port transfer immediately precedes the local bus transfer. In all cases, the setup time to aux_we and the number of wait states remains valid.

Figure 6. Local Bus Timing Waveforms



PARAMETER MEASUREMENT INFORMATION

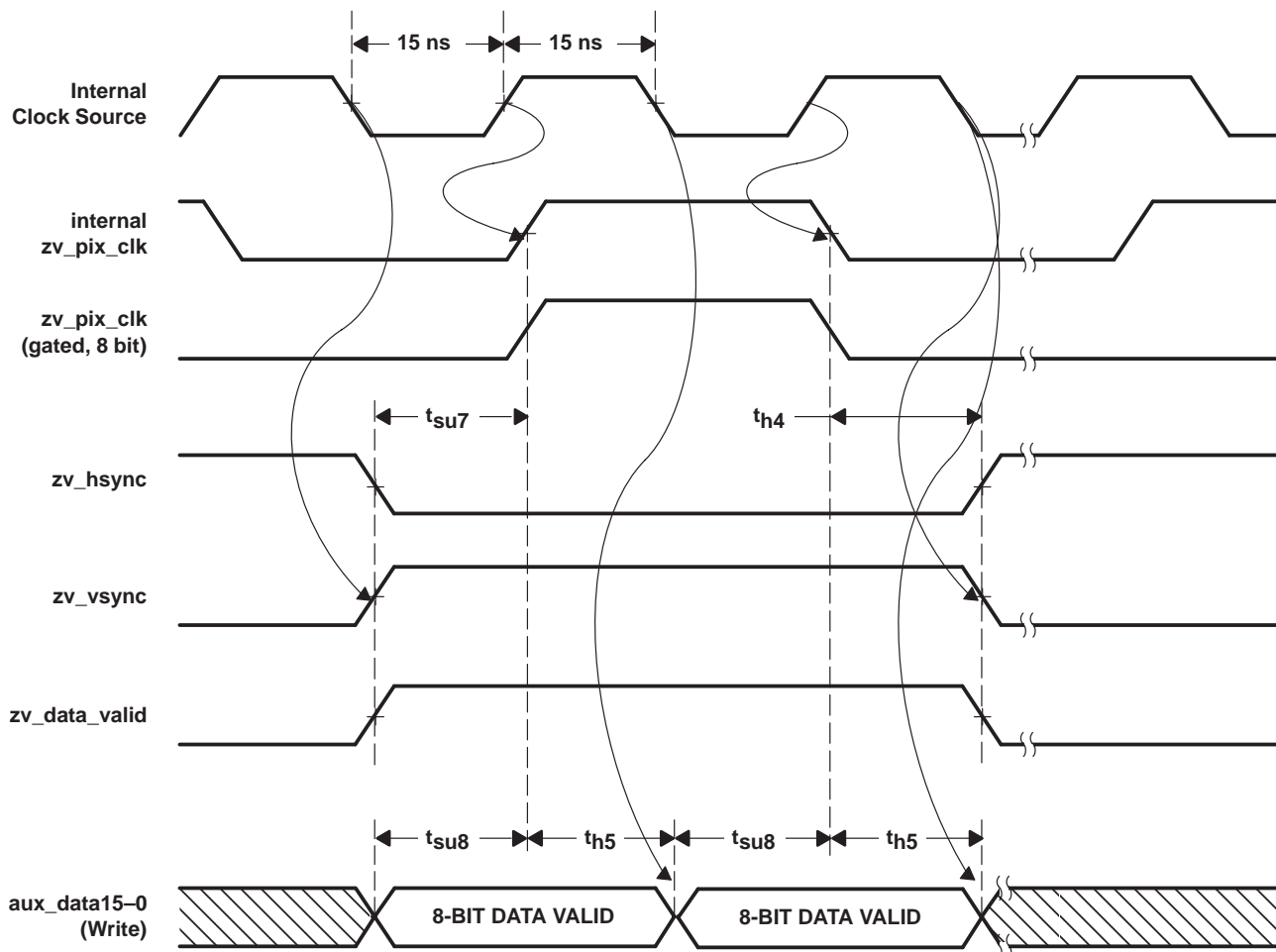

- NOTES: A. The data is in 8-bit mode and `zv_pix_clk` is in divide-by-2 mode.
 B. The timing for these waveforms is for write access to zoom address space.
 C. The `aux_datax` signal meets timing while the `zv_data_valid` signal is asserted. The `aux_datax` signal can be asynchronous to `zv_pix_clk` at other times.
 D. The polarity of `zv_pix_clk` depends on the setting of the `invert_zv_clk` register bit. The polarity shown in this figure is with `invert_zv_clk = 0`.
 E. The timing of these waveforms is with a 30-ns source clock and a 50/50 duty cycle.

Figure 7. Zoom Video IF Timing Waveforms (8 Bit, Divide-By-2 Mode)

TSB12LV21B (PCILynx-2) IEEE 1394 LINK LAYER CONTROLLER

SLLS306–JULY 1998

PARAMETER MEASUREMENT INFORMATION

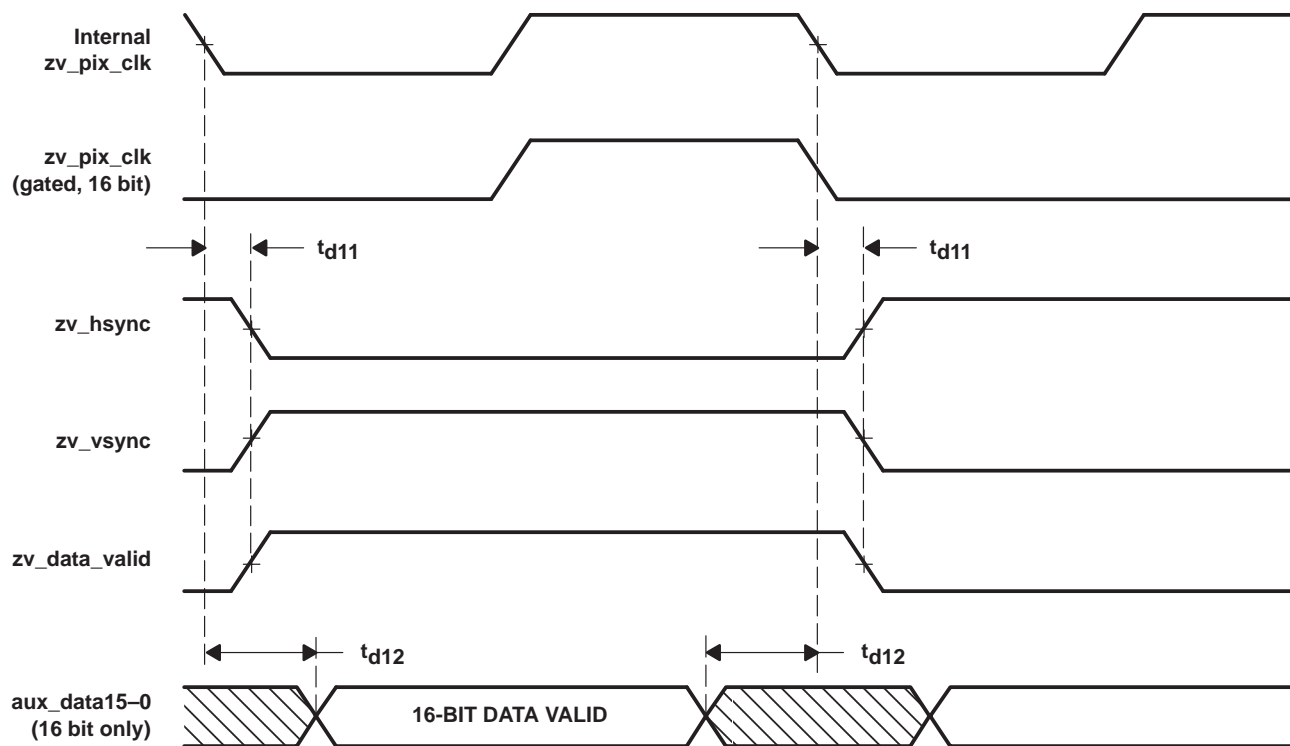

- NOTES:
- A. The data is in 16-bit mode and zv_pix_clk is in divide-by-1 mode.
 - B. The timing for these waveforms is for write access to zoom address space.
 - C. The $aux_data15-0$ signal meets timing while the zv_data_valid signal is asserted. The $aux_data15-0$ signal can be asynchronous to zv_pix_clk at other times.
 - D. The polarity of zv_pix_clk depends on the setting of the $invert_zv_clk$ register bit. The polarity shown in this figure is with $invert_zv_clk = 0$.

Figure 8. Zoom Video IF Timing Waveforms (16 Bit, Divide-By-1 Mode)

PARAMETER MEASUREMENT INFORMATION

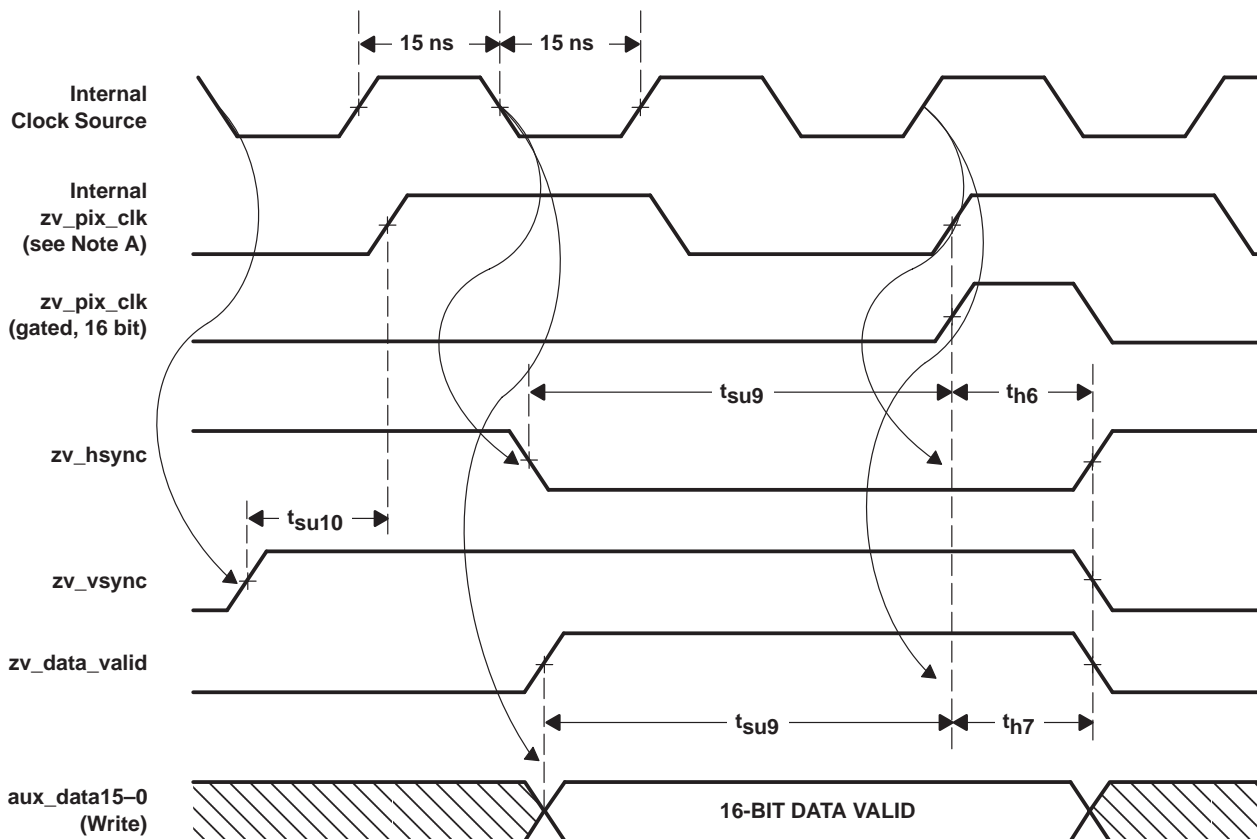

- NOTES:
- A. The data is in 16-bit mode and `zv_pix_clk` is in divide-by-2 mode.
 - B. The timing for these waveforms is for write access to zoom address space.
 - C. The `aux_datax` signal meets timing while the `zv_data_valid` signal is asserted. The `aux_datax` signal can be asynchronous to `zv_pix_clk` at other times.
 - D. The polarity of `zv_pix_clk` depends on the setting of the `invert_zv_clk` terminal. The polarity shown in this figure is with `invert_zv_clk = 0`.
 - E. The timing of these waveforms is with a 30-ns source clock and a 50/50 duty cycle.

Figure 9. Zoom Video IF Timing Waveforms (16 Bit, Divide-By-2 Mode)

APPLICATION INFORMATION

power supply sequencing

Turning power supplies on and off within a mixed 5-V/3.3-V system is an important consideration. A few basic rules need to be observed to avoid damaging PCILynx-2 devices. Check with the manufacturers of all components used in the 3.3-V to 5-V interface to ensure that no unique device characteristics exist that would lead to more restrictive rules.

- When the 3.3-V supply is turned on before turning on the 5-V supply, PCILynx-2 output buffers in a logic 1 state can supply large amounts of current through their clamp diodes to the 5-V supply terminals ($5V V_{CC}$). This can lead to excessive power dissipation and violation of current density limits. However, if the 5-V supply is turned on before the 3.3-V supply, the maximum drain-to-gate voltage of the n-channel transistors in the 5-V tolerant buffers exceeds the recommended value and the effects of channel-hot carries can be accelerated.
- When turning on the power supply, all 3.3-V and 5-V supplies should start ramping up from 0 V and reach 95% of their end-point values within a 25-ms time window. All bus contention between the PCILynx-2 and external devices is eliminated by the end of the 25-ms time window. The preferred order of supply ramping is to ramp the 3.3-V supply followed by the 5-V supply. This order is not mandatory, but it allows a larger cumulative number of power supply events than the reverse order.
- When turning off the power supply, all 3.3-V and 5-V supplies should start ramping down from steady state values and reach 5% of these values within a 25-ms window. All bus contention between the PCILynx-2 and external devices is eliminated by the end of the 25-ms time window. The preferred order of supply ramping is to ramp down the 5-V supply followed by the 3.3-V supply. This order is not mandatory, but it allows a larger cumulative number of power-supply off events than the reverse order.
- A cumulative total of 250 seconds of power supply turnon and turnoff events is allowed during the operating lifetime of the PCILynx-2 under worst-case conditions. Worst-case conditions are where the 5-V supply is ramped up before the 3.3-V supply and the 3.3-V supply is ramped down before the 5-V supply. If the maximum time window of the 25 ms is used, a total of 10,000 power supply on or off events can occur as long as the 25-ms time window is observed.
- An additional precaution must be observed when the PCILynx-2 is connected to a 5-V IEEE 1394 physical-layer device that is powered from the 1394 cable. In this case, it is possible for the physical-layer device to have power while the PCILynx-2 does not. It is essential that the physical-layer device must not supply a high signal on any terminal that connects to the PCILynx-2 while the PCILynx-2 power is off. This is normally achieved through the use of the link-power status terminal on the physical-layer device.

If any of these precautions and guidelines are not followed, the PCILynx-2 device can experience possible failures related to overheating, accumulation of channel-hot carries, and/or metal migration due to excessive current density.

MECHANICAL INFORMATION

PGF (S-PQFP-G176)

PLASTIC QUAD FLATPACK

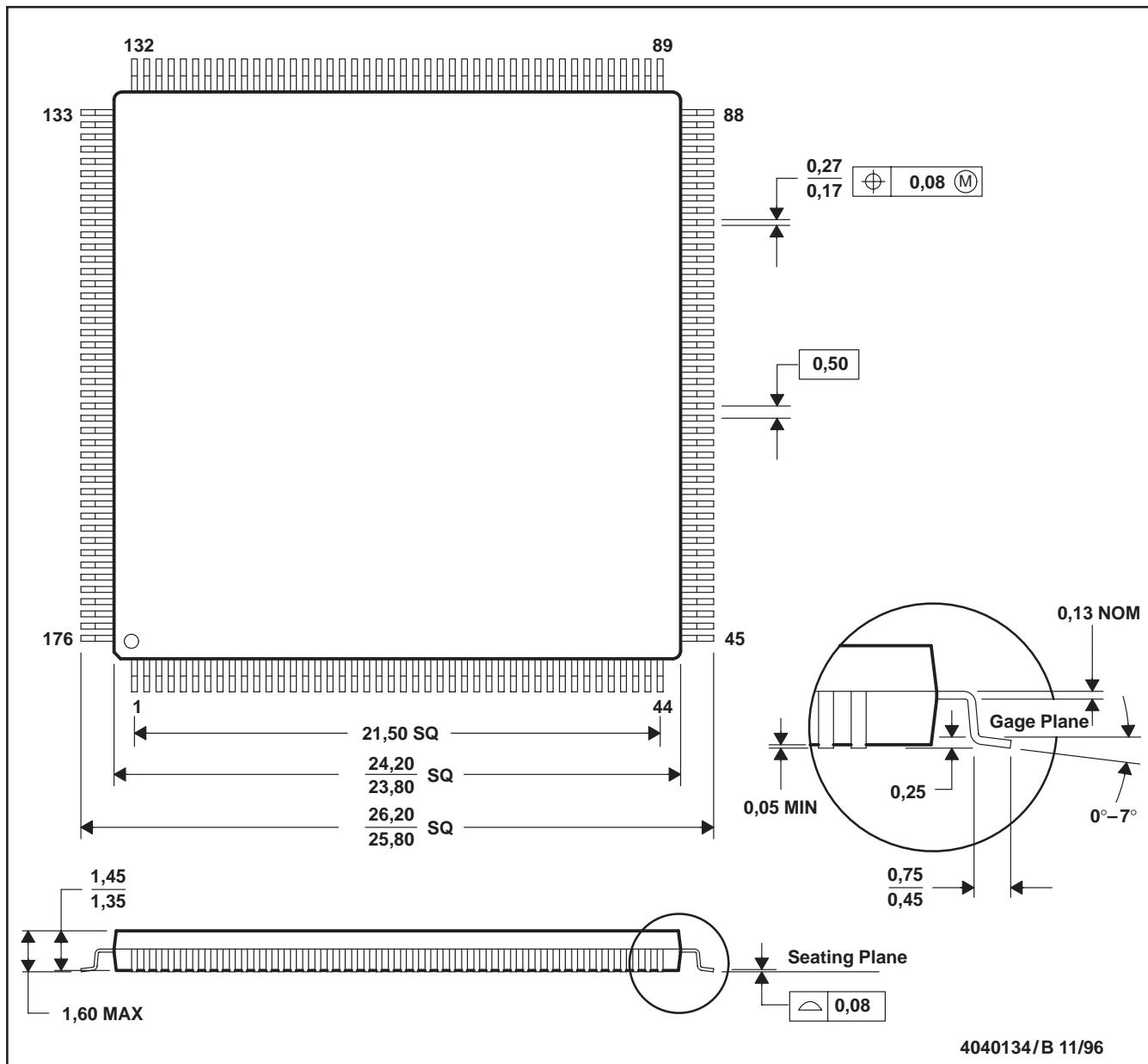

- NOTES: F. All linear dimensions are in millimeters.
G. This drawing is subject to change without notice.
H. Falls within JEDEC MS-026

TSB12LV21B (PCILynx-2) IEEE 1394 LINK LAYER CONTROLLER

SLLS306–JULY 1998

IMPORTANT NOTICE

Texas Instruments and its subsidiaries (TI) reserve the right to make changes to their products or to discontinue any product or service without notice, and advise customers to obtain the latest version of relevant information to verify, before placing orders, that information being relied on is current and complete. All products are sold subject to the terms and conditions of sale supplied at the time of order acknowledgement, including those pertaining to warranty, patent infringement, and limitation of liability.

TI warrants performance of its semiconductor products to the specifications applicable at the time of sale in accordance with TI's standard warranty. Testing and other quality control techniques are utilized to the extent TI deems necessary to support this warranty. Specific testing of all parameters of each device is not necessarily performed, except those mandated by government requirements.

CERTAIN APPLICATIONS USING SEMICONDUCTOR PRODUCTS MAY INVOLVE POTENTIAL RISKS OF DEATH, PERSONAL INJURY, OR SEVERE PROPERTY OR ENVIRONMENTAL DAMAGE ("CRITICAL APPLICATIONS"). TI SEMICONDUCTOR PRODUCTS ARE NOT DESIGNED, AUTHORIZED, OR WARRANTED TO BE SUITABLE FOR USE IN LIFE-SUPPORT DEVICES OR SYSTEMS OR OTHER CRITICAL APPLICATIONS. INCLUSION OF TI PRODUCTS IN SUCH APPLICATIONS IS UNDERSTOOD TO BE FULLY AT THE CUSTOMER'S RISK.

In order to minimize risks associated with the customer's applications, adequate design and operating safeguards must be provided by the customer to minimize inherent or procedural hazards.

TI assumes no liability for applications assistance or customer product design. TI does not warrant or represent that any license, either express or implied, is granted under any patent right, copyright, mask work right, or other intellectual property right of TI covering or relating to any combination, machine, or process in which such semiconductor products or services might be or are used. TI's publication of information regarding any third party's products or services does not constitute TI's approval, warranty or endorsement thereof.

Copyright © 1998, Texas Instruments Incorporated



POST OFFICE BOX 655303 • DALLAS, TEXAS 75265

IMPORTANT NOTICE

Texas Instruments and its subsidiaries (TI) reserve the right to make changes to their products or to discontinue any product or service without notice, and advise customers to obtain the latest version of relevant information to verify, before placing orders, that information being relied on is current and complete. All products are sold subject to the terms and conditions of sale supplied at the time of order acknowledgement, including those pertaining to warranty, patent infringement, and limitation of liability.

TI warrants performance of its semiconductor products to the specifications applicable at the time of sale in accordance with TI's standard warranty. Testing and other quality control techniques are utilized to the extent TI deems necessary to support this warranty. Specific testing of all parameters of each device is not necessarily performed, except those mandated by government requirements.

CERTAIN APPLICATIONS USING SEMICONDUCTOR PRODUCTS MAY INVOLVE POTENTIAL RISKS OF DEATH, PERSONAL INJURY, OR SEVERE PROPERTY OR ENVIRONMENTAL DAMAGE ("CRITICAL APPLICATIONS"). TI SEMICONDUCTOR PRODUCTS ARE NOT DESIGNED, AUTHORIZED, OR WARRANTED TO BE SUITABLE FOR USE IN LIFE-SUPPORT DEVICES OR SYSTEMS OR OTHER CRITICAL APPLICATIONS. INCLUSION OF TI PRODUCTS IN SUCH APPLICATIONS IS UNDERSTOOD TO BE FULLY AT THE CUSTOMER'S RISK.

In order to minimize risks associated with the customer's applications, adequate design and operating safeguards must be provided by the customer to minimize inherent or procedural hazards.

TI assumes no liability for applications assistance or customer product design. TI does not warrant or represent that any license, either express or implied, is granted under any patent right, copyright, mask work right, or other intellectual property right of TI covering or relating to any combination, machine, or process in which such semiconductor products or services might be or are used. TI's publication of information regarding any third party's products or services does not constitute TI's approval, warranty or endorsement thereof.