

TL3x071, TL3x071A, TL3x072, TL3x072A, TL3x074, TL3x074A HIGH-SLEW-RATE, SINGLE-SUPPLY OPERATIONAL AMPLIFIERS

SLOS097C – MARCH 1991 – REVISED AUGUST 1996

- Wide Gain-Bandwidth Product . . . 4.5 MHz
- High Slew Rate . . . 13 V/ μ s
- Fast Settling Time . . . 1.1 μ s to 0.1%
- Wide-Range Single-Supply Operation
4 V to 44 V
- Wide Input Common-Mode Range Includes
Ground (V_{CC-})
- Low Total Harmonic Distortion . . . 0.02%
- Low Input Offset Voltage . . . 3 mV Max
(A Suffix)
- Large Output Voltage Swing
–14.7 V to 14 V (With \pm 15-V Supplies)
- Large Capacitance Drive Capability
10,000 pF
- Excellent Phase Margin . . . 60°
- Excellent Gain Margin . . . 12 dB
- Output Short-Circuit Protection

D OR P PACKAGE
(SINGLE, TOP VIEW)

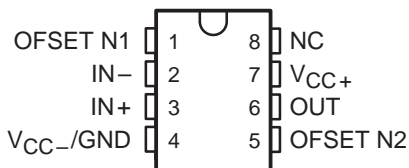

D OR P PACKAGE
(DUAL, TOP VIEW)

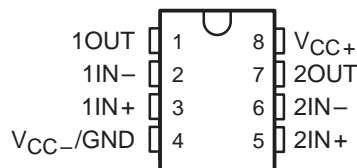

DW PACKAGE
(QUAD, TOP VIEW)

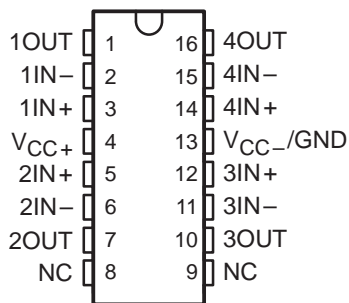

N PACKAGE
(QUAD, TOP VIEW)

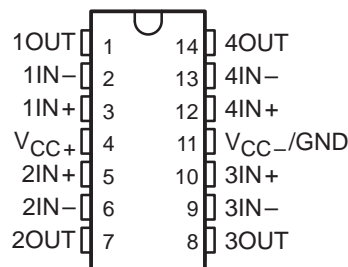

NC – No internal connection

AVAILABLE OPTIONS

T _A	COMPLEXITY	PACKAGE			
		PLASTIC DIP		SMALL OUTLINE	
		STANDARD GRADE	PRIME GRADE	STANDARD GRADE	PRIME GRADE
0°C to 70°C	Single Dual Quad	TL34071P TL34072P TL34074N	TL34071AP TL34072AP TL34074AN	TL34071D TL34072D TL34074DW	TL34071AD TL34072AD TL34074ADW
–40°C to 105°C	Single Dual Quad	TL33071P TL33072P TL33074N	TL33071AP TL33072AP TL33074AN	TL33071D TL33072D TL33074DW	TL33071AD TL33072AD TL33074ADW
–55°C to 125°C	Single Dual Quad	TL35071P TL35072P TL35074N	TL35071AP TL35072AP TL35074AN	TL35071D TL35072D TL35074DW	TL35071AD TL35072AD TL35074ADW

D and DW packages are available taped and reeled. Add R suffix to device type (e.g., TL34071ADR).



Please be aware that an important notice concerning availability, standard warranty, and use in critical applications of Texas Instruments semiconductor products and disclaimers thereto appears at the end of this data sheet.

PRODUCTION DATA information is current as of publication date. Products conform to specifications per the terms of Texas Instruments standard warranty. Production processing does not necessarily include testing of all parameters.

 **TEXAS
INSTRUMENTS**

POST OFFICE BOX 655303 • DALLAS, TEXAS 75265

Copyright © 1996, Texas Instruments Incorporated

TL3x071, TL3x071A, TL3x072, TL3x072A, TL3x074, TL3x074A HIGH-SLEW-RATE, SINGLE-SUPPLY OPERATIONAL AMPLIFIERS

SLOS097C – MARCH 1991 – REVISED AUGUST 1996

description

Quality, low cost, bipolar fabrication with innovative design concepts are employed for the TL33071/2/4, TL34071/2/4, and TL35071/2/4 series of monolithic operational amplifiers. This series of operational amplifiers offers 4.5 MHz of gain bandwidth product, 13 V/ μ s slew rate, and fast settling time without the use of JFET device technology. Although this series can be operated from split supplies, it is particularly suited for single-supply operation since the common-mode input voltage range includes ground potential (V_{CC-}). With a Darlington transistor input stage, this series exhibits high input resistance, low input offset voltage, and high gain. The all-npn output stage, characterized by no dead-band crossover distortion and large output voltage swing, provides high-capacitance drive capability, excellent phase and gain margins, low open-loop high-frequency output impedance, and symmetrical source/sink ac frequency response.

The TL34071/2/4 devices are available in standard or prime performance (A-suffix) grades and are specified over the commercial (0°C to 70°C) temperature range. The TL33071/2/4 devices are available in standard or prime performance (A-suffix) grades and are specified over industrial/vehicular (-40°C to 105°C) temperature range. The TL35071/2/4 devices are available in standard or prime performance (A-suffix) grades and are specified over the military (-55°C to 125°C) temperature range. These low-cost amplifiers are available in single, dual, and quad configurations and are pin compatible with the MC33071/2/4, MC34071/2/4, and MC35071/2/4 series of amplifiers. Packaging options include standard plastic DIP and SO packages.

symbol

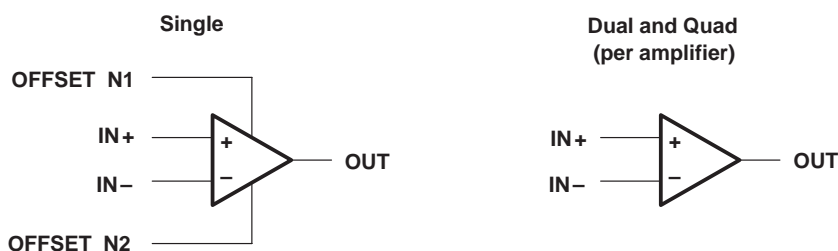

TL3x071, TL3x071A, TL3x072, TL3x072A, TL3x074, TL3x074A HIGH-SLEW-RATE, SINGLE-SUPPLY OPERATIONAL AMPLIFIERS

SLOS097C – MARCH 1991 – REVISED AUGUST 1996

absolute maximum ratings over operating free-air temperature range (unless otherwise noted)†

Supply voltage, V_{CC+} (see Note 1)	22 V
Supply voltage, V_{CC-}	–22 V
Differential input voltage, V_{ID} (see Note 2)	±44 V
Input voltage, V_I (any input)	$V_{CC\pm}$
Input current, I_I (each input)	±1 mA
Output current, I_O	±80 mA
Total current into V_{CC+}	80 mA
Total current out of V_{CC-}	80 mA
Duration of short-circuit current at (or below) 25°C (see Note 3)	unlimited
Continuous total power dissipation	See Dissipation Rating Table
Operating free-air temperature range, T_A : TL3307x	–40°C to 105°C
TL3407x	0°C to 70°C
TL3507x	–55°C to 125°C
Storage temperature range, T_{stg}	–65°C to 150°C
Lead temperature 1.6 mm (1/16 inch) from case for 10 seconds: D, DW, N, or P package	260°C

† Stresses beyond those listed under “absolute maximum ratings” may cause permanent damage to the device. These are stress ratings only, and functional operation of the device at these or any other conditions beyond those indicated under “recommended operating conditions” is not implied. Exposure to absolute-maximum-rated conditions for extended periods may affect device reliability.

- NOTES:
1. All voltage values, except differential voltages, are with respect to the midpoint between V_{CC+} and V_{CC-} .
 2. Differential voltages are at the noninverting input with respect to the inverting input. Excessive current flows if input is brought below $V_{CC-} - 0.3$ V.
 3. The output can be shorted to either supply. Temperature and/or supply voltages must be limited to ensure that the maximum dissipation rating is not exceeded.

DISSIPATION RATING TABLE

PACKAGE	$T_A \leq 25^\circ\text{C}$	DERATING FACTOR ABOVE $T_A = 25^\circ\text{C}$	$T_A = 70^\circ\text{C}$	$T_A = 105^\circ\text{C}$	$T_A = 125^\circ\text{C}$
	POWER RATING		POWER RATING	POWER RATING	POWER RATING
D	725 mW	5.8 mW/°C	464 mW	261 mW	145 mW
DW	1025 mW	8.2 mW/°C	656 mW	369 mW	205 mW
N	1150 mW	9.2 mW/°C	736 mW	414 mW	230 mW
P	1000 mW	8.0 mW/°C	640 mW	360 mW	200 mW

recommended operating conditions

	TL3307x		TL3407x		TL3507x		UNIT
	MIN	MAX	MIN	MAX	MIN	MAX	
Supply voltage, $V_{CC\pm}$	±2	±22	±2	±22	±2	±22	V
Common-mode input voltage, V_{IC}	$V_{CC} = 5$ V		0	2.7	0	2.9	V
	$V_{CC\pm} = \pm 15$ V		–15	12.7	–15	12.9	
Operating free-air temperature, T_A	–40	105	0	70	–55	125	°C



TL3x071, TL3x071A, TL3x072, TL3x072A, TL3x074, TL3x074A HIGH-SLEW-RATE, SINGLE-SUPPLY OPERATIONAL AMPLIFIERS

SLOS097C – MARCH 1991 – REVISED AUGUST 1996

electrical characteristics at specified free-air temperature, $V_{CC\pm} = \pm 15\text{ V}$ (unless otherwise noted)

PARAMETER	TEST CONDITIONS		T_A †	TL3x07xA			TL3x07x			UNIT
				MIN	TYP‡	MAX	MIN	TYP‡	MAX	
V_{IO} Input offset voltage		$V_{CC} = 5\text{ V}$	25°C	0.5	3		1.5	5	mV	
		$V_{CC} = \pm 15\text{ V}$	25°C	0.5	3		1.0	5		
			Full range			5		7		
αV_{IO} Temperature coefficient of input offset voltage	$V_{IC} = 0,$ $V_O = 0,$ $R_S = 50\ \Omega$	$V_{CC} = \pm 15\text{ V}$	Full range	10			10		$\mu\text{V}/^\circ\text{C}$	
I_{IO} Input offset current		$V_{CC} = \pm 15\text{ V}$	25°C	7	100		7	100	nA	
			Full range		250		250			
I_{IB} Input bias current		$V_{CC} = 5\text{ V}$	25°C	-0.8	-2		-0.8	-2	μA	
			Full range		-2.3		-2.3			
		$V_{CC} = \pm 15\text{ V}$	25°C	-0.7	-1.5		-0.7	-1.5		
Full range			-1.8		-1.8					
V_{ICR} Common-mode input voltage range	$R_S = 50\ \Omega$		25°C	-15 to 13.2			-15 to 13.2	V		
			Full range	-15 to 12.8			-15 to 12.8			
V_{OH} High-level output voltage		$V_{CC+} = 5\text{ V}, V_{CC-} = 0,$ $R_L = 2\text{ k}\Omega$	25°C	3.7	4		3.7	4	V	
		$R_L = 10\text{ k}\Omega$	25°C	13.6	14		13.6	14		
		$R_L = 2\text{ k}\Omega$	Full range	13.4			13.4			
V_{OL} Low-level output voltage		$V_{CC+} = 5\text{ V}, V_{CC-} = 0,$ $R_L = 2\text{ k}\Omega$	25°C	0.1	0.3		0.1	0.3	V	
		$R_L = 10\text{ k}\Omega$	25°C	-14.7	-14.3		-14.7	-14.3		
		$R_L = 2\text{ k}\Omega$	Full range	-13.5			-13.5			
A_{VD} Large-signal differential voltage amplification	$V_O = \pm 10\text{ V}, R_L = 2\text{ k}\Omega$		25°C	50	100		25	100	V/mV	
			Full range	25			20			
I_{OS} Short-circuit output current	Source: $V_{ID} = 1\text{ V}, V_O = 0$ Sink: $V_{ID} = -1\text{ V}, V_O = 0$		25°C	-10	-30		-10	-30	mA	
				20	30		20	30		
CMRR Common-mode rejection ratio	$V_{IC} = V_{ICRmin},$ $R_S = 50\ \Omega$		25°C	80	97		70	97	dB	
k_{SVR} Supply-voltage rejection ratio ($\Delta V_{CC\pm}/\Delta V_{IO}$)	$V_{CC\pm} = \pm 13.5\text{ V}$ to $\pm 16.5\text{ V}, R_S = 100\ \Omega$		25°C	80	97		70	97	dB	
I_{CC} Supply current (per channel)	$V_O = 0,$ No Load		25°C	3.5	4.5		3.5	4.5	mA	
			Full range	4.7			4.7			
	$V_{CC+} = 5\text{ V}, V_{CC-} = 0,$ $V_O = 0,$ No Load		25°C	3.4	4.4		3.4	4.4		
			Full range	4.6			4.6			

† Full range is 0°C to 70°C for the TL3407x devices, and -40°C to 105°C for the TL3307x devices, and -55°C to 125°C for the TL3507x devices.
‡ All typical values are at $T_A = 25^\circ\text{C}$.



TL3x071, TL3x071A, TL3x072, TL3x072A, TL3x074, TL3x074A HIGH-SLEW-RATE, SINGLE-SUPPLY OPERATIONAL AMPLIFIERS

SLOS097C – MARCH 1991 – REVISED AUGUST 1996

operating characteristics, $V_{CC\pm} = \pm 15\text{ V}$, $T_A = 25^\circ\text{C}$

PARAMETER		TEST CONDITIONS		TL3x07xA			TL3x07x			UNIT
				MIN	TYP	MAX	MIN	TYP	MAX	
SR+	Positive slew rate	$V_I = -10\text{ V to }10\text{ V}$, $R_L = 2\text{ k}\Omega$	$A_V = 1$	8	10		8	10	V/ μ s	
SR-	Negative slew rate		$A_V = -1$					13		
t_s	Settling time	$A_{VD} = -1$, 10-V step	To 0.1%		1.1			1.1	μ s	
			To 0.01%		2.2			2.2		
V_n	Equivalent input noise voltage	$f = 1\text{ kHz}$, $R_S = 100\ \Omega$		32			32	nV/ $\sqrt{\text{Hz}}$		
I_n	Equivalent input noise current	$f = 1\text{ kHz}$		0.22			0.22	pA/ $\sqrt{\text{Hz}}$		
THD	Total harmonic distortion	$V_O = 2\text{ V to }20\text{ V}$, $R_L = 2\text{ k}\Omega$, $A_{VD} = 10$, $f = 10\text{ kHz}$		0.02			0.02	%		
GBW	Gain-bandwidth product	$f = 100\text{ kHz}$	3.5	4.5		3.5	4.5	MHz		
BW	Power bandwidth	$R_L = 2\text{ k}\Omega$, $V_{O(PP)} = 20\text{ V}$, $A_{VD} = 1$, THD = 5.0%		200			200	kHz		
ϕ_m	Phase margin	$R_L = 2\text{ k}\Omega$, $C_L = 0$		60°			60°			
		$R_L = 2\text{ k}\Omega$, $C_L = 300\text{ pF}$		40°			40°			
	Gain margin	$R_L = 2\text{ k}\Omega$, $C_L = 0$		12			12	dB		
		$R_L = 2\text{ k}\Omega$, $C_L = 300\text{ pF}$		4			4			
r_i	Differential input resistance	$V_{IC} = 0$		150			150	M Ω		
C_i	Input capacitance	$V_{IC} = 0$		2.5			2.5	pF		
	Channel separation	$f = 10\text{ kHz}$		120			120	dB		
z_o	Open-loop output impedance	$f = 1\text{ MHz}$		30			30	Ω		

IMPORTANT NOTICE

Texas Instruments and its subsidiaries (TI) reserve the right to make changes to their products or to discontinue any product or service without notice, and advise customers to obtain the latest version of relevant information to verify, before placing orders, that information being relied on is current and complete. All products are sold subject to the terms and conditions of sale supplied at the time of order acknowledgement, including those pertaining to warranty, patent infringement, and limitation of liability.

TI warrants performance of its semiconductor products to the specifications applicable at the time of sale in accordance with TI's standard warranty. Testing and other quality control techniques are utilized to the extent TI deems necessary to support this warranty. Specific testing of all parameters of each device is not necessarily performed, except those mandated by government requirements.

CERTAIN APPLICATIONS USING SEMICONDUCTOR PRODUCTS MAY INVOLVE POTENTIAL RISKS OF DEATH, PERSONAL INJURY, OR SEVERE PROPERTY OR ENVIRONMENTAL DAMAGE ("CRITICAL APPLICATIONS"). TI SEMICONDUCTOR PRODUCTS ARE NOT DESIGNED, AUTHORIZED, OR WARRANTED TO BE SUITABLE FOR USE IN LIFE-SUPPORT DEVICES OR SYSTEMS OR OTHER CRITICAL APPLICATIONS. INCLUSION OF TI PRODUCTS IN SUCH APPLICATIONS IS UNDERSTOOD TO BE FULLY AT THE CUSTOMER'S RISK.

In order to minimize risks associated with the customer's applications, adequate design and operating safeguards must be provided by the customer to minimize inherent or procedural hazards.

TI assumes no liability for applications assistance or customer product design. TI does not warrant or represent that any license, either express or implied, is granted under any patent right, copyright, mask work right, or other intellectual property right of TI covering or relating to any combination, machine, or process in which such semiconductor products or services might be or are used. TI's publication of information regarding any third party's products or services does not constitute TI's approval, warranty or endorsement thereof.