

**THS3001**  
**High-Speed Current-Feedback**  
**Operational Amplifier**  
**Evaluation Module**

*User's Guide*



***THS3001***  
***High-Speed Current-Feedback***  
***Operational Amplifier***  
***Evaluation Module***

***User's Guide***

***SLOU021***  
***June 1998***



Printed on Recycled Paper

## IMPORTANT NOTICE

Texas Instruments and its subsidiaries (TI) reserve the right to make changes to their products or to discontinue any product or service without notice, and advise customers to obtain the latest version of relevant information to verify, before placing orders, that information being relied on is current and complete. All products are sold subject to the terms and conditions of sale supplied at the time of order acknowledgement, including those pertaining to warranty, patent infringement, and limitation of liability.

TI warrants performance of its semiconductor products to the specifications applicable at the time of sale in accordance with TI's standard warranty. Testing and other quality control techniques are utilized to the extent TI deems necessary to support this warranty. Specific testing of all parameters of each device is not necessarily performed, except those mandated by government requirements.

CERTAIN APPLICATIONS USING SEMICONDUCTOR PRODUCTS MAY INVOLVE POTENTIAL RISKS OF DEATH, PERSONAL INJURY, OR SEVERE PROPERTY OR ENVIRONMENTAL DAMAGE ("CRITICAL APPLICATIONS"). TI SEMICONDUCTOR PRODUCTS ARE NOT DESIGNED, AUTHORIZED, OR WARRANTED TO BE SUITABLE FOR USE IN LIFE-SUPPORT DEVICES OR SYSTEMS OR OTHER CRITICAL APPLICATIONS. INCLUSION OF TI PRODUCTS IN SUCH APPLICATIONS IS UNDERSTOOD TO BE FULLY AT THE CUSTOMER'S RISK.

In order to minimize risks associated with the customer's applications, adequate design and operating safeguards must be provided by the customer to minimize inherent or procedural hazards.

TI assumes no liability for applications assistance or customer product design. TI does not warrant or represent that any license, either express or implied, is granted under any patent right, copyright, mask work right, or other intellectual property right of TI covering or relating to any combination, machine, or process in which such semiconductor products or services might be or are used. TI's publication of information regarding any third party's products or services does not constitute TI's approval, warranty or endorsement thereof.

# Preface

---

---

---

---

## ***Related Documentation From Texas Instruments***

- ***THS3001 HIGH-SPEED CURRENT-FEEDBACK OPERATIONAL AMPLIFIER*** (literature number SLOS217) This is the data sheet for the THS3001 operational amplifier integrated circuit that is used in the THS3001 evaluation module.

## ***FCC Warning***

This equipment is intended for use in a laboratory test environment only. It generates, uses, and can radiate radio frequency energy and has not been tested for compliance with the limits of computing devices pursuant to subpart J of part 15 of FCC rules, which are designed to provide reasonable protection against radio frequency interference. Operation of this equipment in other environments may cause interference with radio communications, in which case the user at his own expense will be required to take whatever measures may be required to correct this interference.

## ***Trademarks***

TI is a trademark of Texas Instruments Incorporated.

**If You Need Assistance. . .**

<b>If you want to . . .</b>	<b>Do this . . .</b>
Request more information about Texas Instruments mixed-signal products	Call the PIC† hotline: <b>(972) 644-5580</b>  Or send a fax to the PIC: <b>(972) 480-7800</b>  Or write to: Texas Instruments Incorporated Product Information Center, MS 3123 P.O. Box 660246 Dallas, Texas 75266
Order Texas Instruments documentation	Call the PIC† hotline: <b>(972) 644-5580</b>
Ask questions about product operation or report suspected problems	Call the PIC† hotline: <b>(972) 644-5580</b>
Report mistakes in this document or any other TI documentation	Send a fax to MSP Marketing Documentation Correction: <b>(972) 480-3160</b>  Or send your comments to: Texas Instruments Incorporated MSP Marketing Documentation, MS 8710 P.O. Box 660199 Dallas, Texas 75266-0199

† Texas Instruments Product Information Center

# Contents

---

---

---

<b>1</b>	<b>General Information</b>	<b>1-1</b>
1.1	Features	1-1
1.2	Description	1-2
1.3	THS3001 EVM Specifications	1-3
1.4	Using The THS3001 EVM	1-4
1.5	THS3001 EVM Performance	1-5
1.6	General High-Speed Amplifier Design Considerations	1-6
<b>2</b>	<b>Reference</b>	<b>2-1</b>
2.1	THS3001 High-Speed Operational Amplifier EVM Parts List	2-2
2.2	THS3001 EVM Board Layouts	2-2

# Figures

---

---

---

1-1	THS3001 Evaluation Module	1-2
1-2	THS3001 EVM Schematic	1-2
1-3	THS3001 EVM Frequency Response with Gain = 2	1-5
1-4	THS3001 EVM Frequency Response with Inverting Gain = 1	1-5
2-1	THS3001 EVM Component Placement Silkscreen and Solder Pads	2-2
2-1	THS3001 EVM PC Board Layout — Component Side	2-3
2-2	THS3001 EVM PC Board Layout — Back Side	2-3

# Tables

---

---

---

2-1	THS3001 EVM Parts List	2-2
-----	------------------------	-----





# General Information

---

---

---

This chapter details the Texas Instruments (TI™) THS3001 High-Speed Operational Amplifier Evaluation Module (EVM), SLOP130. It includes a list of EVM features, a brief description of the module illustrated with a pictorial and a schematic diagram, EVM specifications, details on connecting and using the EVM, and a discussion on high-speed amplifier design considerations.

<b>Topic</b>	<b>Page</b>
1.1 Features .....	1-1
1.2 Description .....	1-2
1.3 THS3001 EVM Specifications .....	1-3
1.4 Using The THS3001 EVM .....	1-4
1.5 THS3001 EVM Performance .....	1-5
1.6 General High-Speed Amplifier Design Considerations .....	1-6

## 1.1 Features

THS3001 Operational Amplifier EVM features include:

- High Bandwidth — 340 MHz,  $-3$  dB at  $\pm 15$  V<sub>CC</sub> & Gain = 2
- $\pm 5$ -V to  $\pm 15$ -V Operation
- Inverting and Noninverting Single-Ended Inputs
- Module Gain Set to +2 (Noninverting) and  $-1$  (Inverting) — Adjustable Through Component Change.
- Nominal 50- $\Omega$  Impedance Inputs and Outputs
- Standard SMA Miniature RF Connectors
- Good Example of High-Speed Amplifier Design and Layout

## 1.2 Description

The TI THS3001 High-Speed Current-Feedback Operational Amplifier Evaluation Module (EVM) is a complete high-speed amplifier circuit. It consists of the TI THS3001 High-Speed Current-Feedback Operational Amplifier IC, along with a small number of passive parts, mounted on a small circuit board measuring approximately 1.7 inch by 1.4 inch (Figure 1–1). The EVM uses standard SMA miniature RF connectors for inputs and outputs and is completely assembled, fully tested, and ready to use — just connect it to power, a signal source, and a load (if desired).

Figure 1–1. THS3001 Evaluation Module

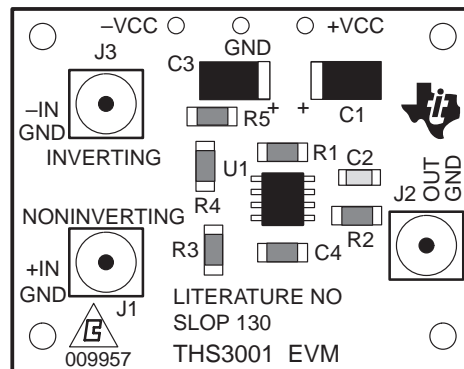

The THS3001 EVM is equipped with both noninverting and inverting inputs. The noninverting input is set for a gain of 2 and the inverting input is set for a gain of 1. Each input is terminated with a 50-Ω resistor to provide correct line impedance matching (Figure 1–2). The amplifier IC output is routed through a 50-Ω resistor both to provide correct line impedance matching and to help isolate capacitive loading on the output of the amplifier. Capacitive loading directly on the output of the IC decreases the amplifier's phase margin and can result in peaking or oscillations.

Figure 1–2. THS3001 EVM Schematic

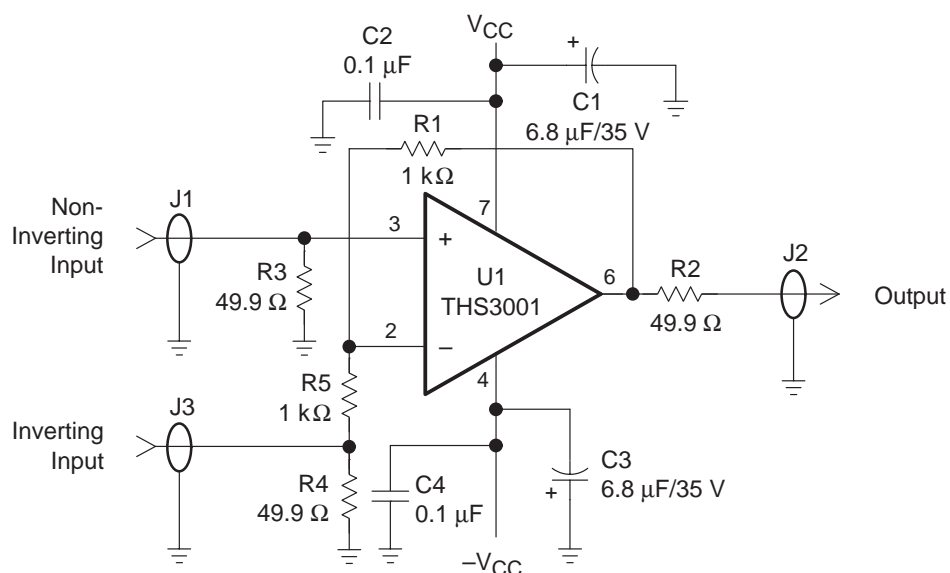

Even though the THS3001 is a current-feedback amplifier, the gain of the EVM can easily be changed to support a particular application by simply changing the ratio of resistors R1, R4, and R5 as described in the following equations:

$$\text{Inverting Gain} = \frac{-R_F}{R_G} = \frac{-R1}{R5}$$

$$\text{Noninverting Gain} = 1 + \frac{R_F}{R_G} = 1 + \frac{R1}{R4 + R5}$$

In addition, some applications, such as those for video, may require the use of 75-Ω cable and 75-Ω EVM input termination and output isolation resistors.

Any of the resistors on the EVM board can be replaced with a resistor of a different value; however, care must be taken because the surface-mount solder pads on the board are somewhat fragile and will not survive many desoldering/soldering operations.

Because of the current feedback architecture, extra care must be taken to ensure that a feedback resistor is always included in the design. In addition, there must never be a capacitor directly in the feedback path between the amplifier output and the noninverting input. Disregarding this guideline will likely result in a part that oscillates.

Note that external factors can significantly affect the overall gain of the EVM. For example, connecting test equipment with 50-Ω input impedance to the EVM output will divide the output signal level by a factor of 2 (assuming the output isolation resistor on the EVM board remains 50 Ω). Similar effects can occur at the input, depending upon how the input signal sources are configured. The gain equations given above assume no signal loss in either the input or the output.

The EVM circuit board is an excellent example of proper board layout for high-speed amplifier designs and can be used as a guide for user application board layouts.

### 1.3 THS3001 EVM Specifications

Supply voltage range, $\pm V_{CC}$ .....	$\pm 5$ V to $\pm 15$ V
Supply current, $I_{CC}$ .....	6.5 mA Typ
Input voltage, $V_I$ .....	$\pm V_{CC}$ , Max
Output drive, $I_O$ .....	100 mA, Typ
Continuous power dissipation at $T_A = 25^\circ\text{C}$ .....	740 mW

For complete THS3001 amplifier IC specifications and parameter measurement information, and additional application information, see the THS3001 data sheet, TI Literature Number SLOS217.

## 1.4 Using The THS3001 EVM

The THS3001 EVM operates from power-supply voltages ranging from  $\pm 5$  V to  $\pm 15$  V. As shipped, the inverting input gain of the module is set to 1, the noninverting input gain is set to 2, and signal inputs on the module are terminated for 50- $\Omega$  nominal impedance cables. An oscilloscope is typically used to view and analyze the EVM output signal.

- 1) Ensure that all power supplies are set to **OFF** before making power supply connections to the THS3001 EVM.
- 2) Select the operating voltage for the EVM and connect appropriate split power supplies to the pads on the module marked **-VCC** and **+VCC**.
- 3) Connect the power supply ground to the module pad marked **GND**.
- 4) Connect an oscilloscope to the module SMA output connector (**J2**) through a 50- $\Omega$  nominal impedance cable (an oscilloscope having a 50- $\Omega$  input termination is preferred for examining very high frequency signals).
- 5) Set the power supply to **ON**.
- 6) Connect the signal input to either the noninverting input (**J1**) for a gain of 2, or to the inverting input (**J3**) for a gain of 1.

Note that each input connector is terminated with a 50- $\Omega$  resistor to ground. With a 50- $\Omega$  source impedance, the voltage seen by the THS3001 amplifier IC on the module will be  $\frac{1}{2}$  the source signal voltage applied to the EVM.

- 7) Verify the output signal on the oscilloscope.

Note that the signal shown on an oscilloscope with a 50- $\Omega$  input impedance will be  $\frac{1}{2}$  the actual THS3001 amplifier IC output voltage. This is due to the voltage division between the output resistor (R2) and the oscilloscope input impedance.

### 1.5 THS3001 EVM Performance

Figure 1–3 shows the typical frequency response of the THS3001 EVM using the noninverting input ( $G = 2$ ). Typical values show a  $-3$ -dB bandwidth of 340 MHz with a  $\pm 15$ -V power supply and 260 MHz with a  $\pm 5$ -V power supply. They also show a  $-0.1$ -dB frequency response of 17 MHz with a  $\pm 15$ -V power supply and 20 MHz with a  $\pm 5$ -V power supply.

Figure 1–3. THS3001 EVM Frequency Response with Gain = 2

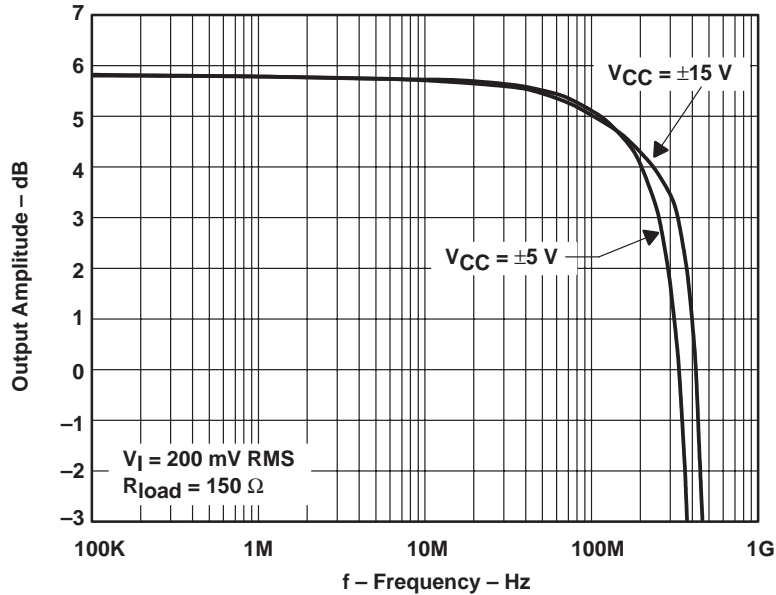
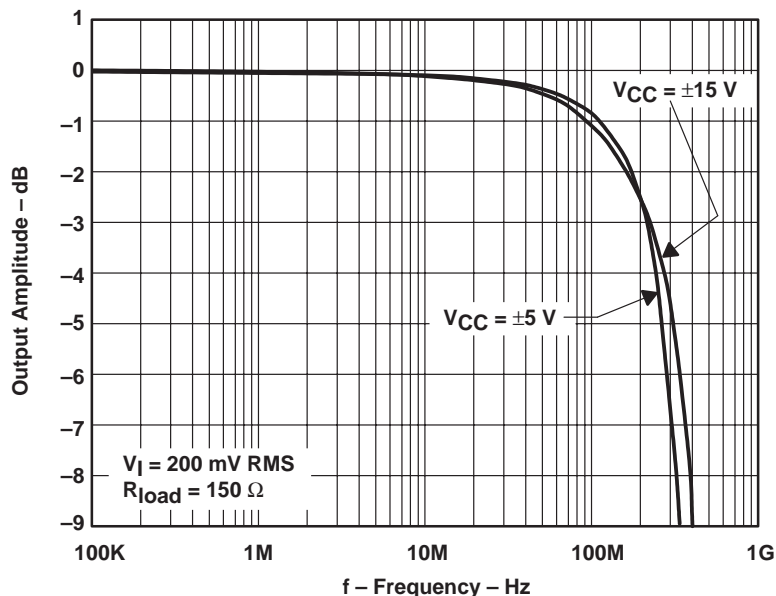

Figure 1–4 shows the typical frequency response of the THS3001 EVM using the inverting input ( $G = 1$ ). Typical  $-0.1$  dB bandwidths are 15 MHz with a  $\pm 15$ -V power supply and 17 MHz with a  $\pm 5$ -V power supply. Typical  $-3$ -dB bandwidths are 220 MHz at  $\pm 15$ -V and 210 MHz at  $\pm 5$ -V.

Figure 1–4. THS3001 EVM Frequency Response with Inverting Gain = 1



## 1.6 General High-Speed Amplifier Design Considerations

The THS3001 EVM layout has been designed and optimized for use with high-speed signals and can be used as an example when designing THS3001 applications. Careful attention has been given to component selection, grounding, power supply bypassing, and signal path layout. Disregard of these basic design considerations could result in less than optimum performance of the THS3001 high-speed, current-feedback video operational amplifier.

Surface mount components were selected because of the extremely low lead inductance associated with this technology. Also, because surface mount components are physically small, the layout can be very compact. This helps minimize both stray inductance and capacitance.

Tantalum power supply bypass capacitors (C1 and C3) at the power input pads help supply currents for rapid, large signal changes at the amplifier output. The 0.1  $\mu\text{F}$  power supply bypass capacitors (C2 and C4) were placed as close as possible to the IC power input pins in order to keep the PCB trace inductance to a minimum. This improves high-frequency bypassing and reduces harmonic distortion.

A proper ground plane on both sides of the PCB should always be used with high-speed circuit design. This provides low-inductive ground connections for return current paths. In the area of the amplifier IC input pins, however, the ground plane was removed to minimize stray capacitance and reduce ground plane noise coupling into these pins. This is especially important for the inverting pin while the amplifier is operating in the noninverting mode. Because the voltage at this pin swings directly with the noninverting input voltage, any stray capacitance would allow currents to flow into the ground plane, causing possible gain error and/or oscillation. Capacitance variations at the amplifier IC inverting input pin of less than 1 pF can significantly affect the response of the amplifier.

In general, it is always best to keep signal lines as short and as straight as possible. Sharp 90° corners should be avoided — round corners or a series of 45° bends should be used, instead. Stripline techniques should also be incorporated when signal lines are greater than three inches in length. These traces should be designed with a characteristic impedance of either 50  $\Omega$  or 75  $\Omega$ , as required by the application. Such signal lines should also be properly terminated with an appropriate resistor.

Finally, proper termination of all inputs and outputs should be incorporated into the layout. Unterminated lines, such as coaxial cable, can appear to be a reactive load to the amplifier IC. By terminating a transmission line with its characteristic impedance, the amplifier's load then appears to be purely resistive and reflections are absorbed at each end of the line. Another advantage of using an output termination resistor is that capacitive loads are isolated from the amplifier output. This isolation helps minimize the reduction in amplifier phase-margin and improves the amplifier stability for improved performance such as reduced peaking and settling times.

# Reference

---

---

---

---

---

This chapter includes a parts list and PCB layout illustrations for the THS3001 EVM.

<b>Topic</b>	<b>Page</b>
<b>2.1 THS3001 High-Speed Operational Amplifier EVM Parts List . . . . .</b>	<b>2-2</b>
<b>2.2 THS3001 EVM Board Layouts . . . . .</b>	<b>2-2</b>

## 2.1 THS3001 High-Speed Current-Feedback Video Operational Amplifier EVM Parts List

Table 2–1. THS3001 EVM Parts List

Reference	Description	Size	Manufacturer/Digi-Key Part Number
C1, C3	Capacitor, 6.8 $\mu$ F, 35 V, SM	D	Sprague 293D685X9035D2T
C2, C4	Capacitor, 0.1 $\mu$ F, ceramic, 10%, SM	1206	Sprague 11C1201E104M5NT
J1, J2, J3	Connector, SMA 50- $\Omega$ vertical PC mount, through-hole		Amphenol ARF1205–ND
R2, R3, R4	Resistor, 49.9 $\Omega$ , 1%, 1/10 W, SM	1206	Digi-Key P49.9CTR–ND
R1, R5	Resistor, 1 k $\Omega$ , 1%, 1/10 W, SM	1206	Digi-Key P1.0KCTR–ND
U1	IC, THS3001, operational amplifier	SOIC-8	TI THS3001
PCB1	PCB, THS3001 EVM		

## 2.2 THS3001 EVM Board Layouts

Board layout examples of the THS3001 EVM PCB are shown in the following illustrations. They are not to scale and appear here only as a reference.

Figure 2–1. THS3001 EVM Component Placement Silkscreen and Solder Pads

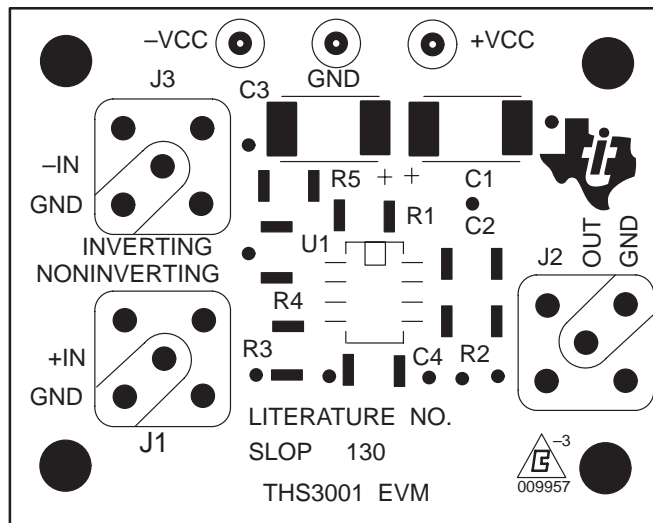



Figure 2–2. THS3001 EVM PC Board Layout – Component Side

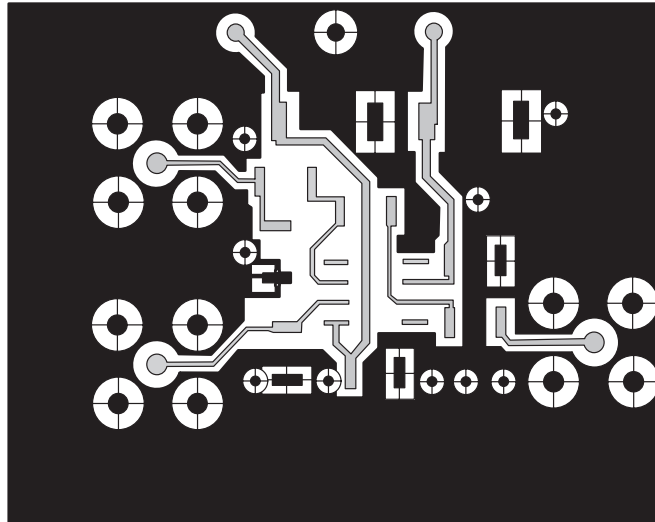
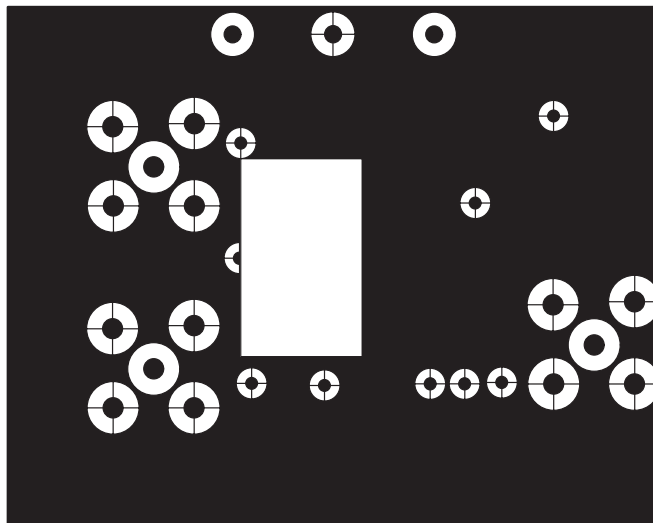

Figure 2–3. THS3001 EVM PC Board Layout – Back Side





## **IMPORTANT NOTICE**

Texas Instruments and its subsidiaries (TI) reserve the right to make changes to their products or to discontinue any product or service without notice, and advise customers to obtain the latest version of relevant information to verify, before placing orders, that information being relied on is current and complete. All products are sold subject to the terms and conditions of sale supplied at the time of order acknowledgement, including those pertaining to warranty, patent infringement, and limitation of liability.

TI warrants performance of its semiconductor products to the specifications applicable at the time of sale in accordance with TI's standard warranty. Testing and other quality control techniques are utilized to the extent TI deems necessary to support this warranty. Specific testing of all parameters of each device is not necessarily performed, except those mandated by government requirements.

**CERTAIN APPLICATIONS USING SEMICONDUCTOR PRODUCTS MAY INVOLVE POTENTIAL RISKS OF DEATH, PERSONAL INJURY, OR SEVERE PROPERTY OR ENVIRONMENTAL DAMAGE ("CRITICAL APPLICATIONS"). TI SEMICONDUCTOR PRODUCTS ARE NOT DESIGNED, AUTHORIZED, OR WARRANTED TO BE SUITABLE FOR USE IN LIFE-SUPPORT DEVICES OR SYSTEMS OR OTHER CRITICAL APPLICATIONS. INCLUSION OF TI PRODUCTS IN SUCH APPLICATIONS IS UNDERSTOOD TO BE FULLY AT THE CUSTOMER'S RISK.**

In order to minimize risks associated with the customer's applications, adequate design and operating safeguards must be provided by the customer to minimize inherent or procedural hazards.

TI assumes no liability for applications assistance or customer product design. TI does not warrant or represent that any license, either express or implied, is granted under any patent right, copyright, mask work right, or other intellectual property right of TI covering or relating to any combination, machine, or process in which such semiconductor products or services might be or are used. TI's publication of information regarding any third party's products or services does not constitute TI's approval, warranty or endorsement thereof.