

L293D QUADRUPLE HALF-H DRIVER

SLRS008A – SEPTEMBER 1986 – REVISED MAY 1990

- 600-mA Output Current Capability Per Driver
- Pulsed Current 1.2-A Per Driver
- Output Clamp Diodes for Inductive Transient Suppression
- Wide Supply Voltage Range 4.5 V to 36 V
- Separate Input-Logic Supply
- Thermal Shutdown
- Internal ESD Protection
- High-Noise-Immunity Inputs
- Functional Replacement for SGS L293D

description

The L293D is a quadruple high-current half-H driver designed to provide bidirectional drive currents of up to 600-mA at voltages from 4.5 V to 36 V. It is designed to drive inductive loads such as relays, solenoids, dc and bipolar stepping motors, as well as other high-current/high-voltage loads in positive-supply applications.

All inputs are TTL-compatible. Each output is a complete totem-pole drive circuit with a Darlington transistor sink and a pseudo-Darlington source. Drivers are enabled in pairs with drivers 1 and 2 enabled by 1,2EN and drivers 3 and 4 enabled by 3,4EN. When an enable input is high, the associated drivers are enabled, and their outputs are active and in phase with their inputs. External high-speed output clamp diodes should be used for inductive transient suppression. When the enable input is low, those drivers are disabled, and their outputs are off and in a high-impedance state. With the proper data inputs, each pair of drivers form a full-H (or bridge) reversible drive suitable for solenoid or motor applications.

A V_{CC1} terminal, separate from V_{CC2} , is provided for the logic inputs to minimize device power dissipation.

The L293D is designed for operation from 0°C to 70°C.

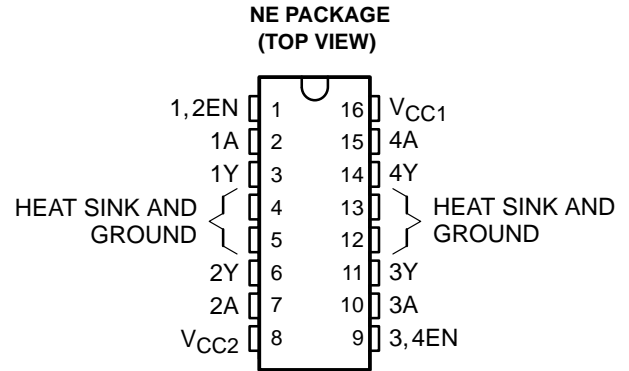

logic symbol†

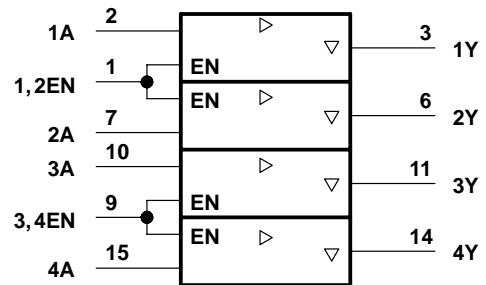

† This symbol is in accordance with ANSI/IEEE Std 91-1984 and IEC Publication 617-12.

logic diagram

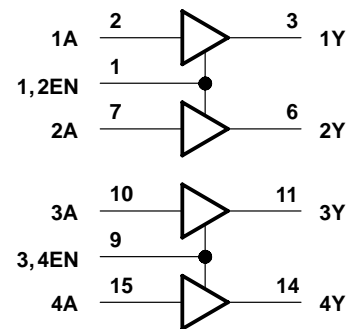

FUNCTION TABLE
(each driver)

INPUTS‡		OUTPUT
A	EN	Y
H	H	H
L	H	L
X	L	Z

H = high-level, L = low level,
X = irrelevant, Z = high-impedance (off)
‡ In the thermal shutdown mode, the output is in the high-impedance state regardless of the input levels.

L293D QUADRUPLE HALF-H DRIVER

SLRS008A – SEPTEMBER 1986 – REVISED MAY 1990

schematics of inputs and outputs

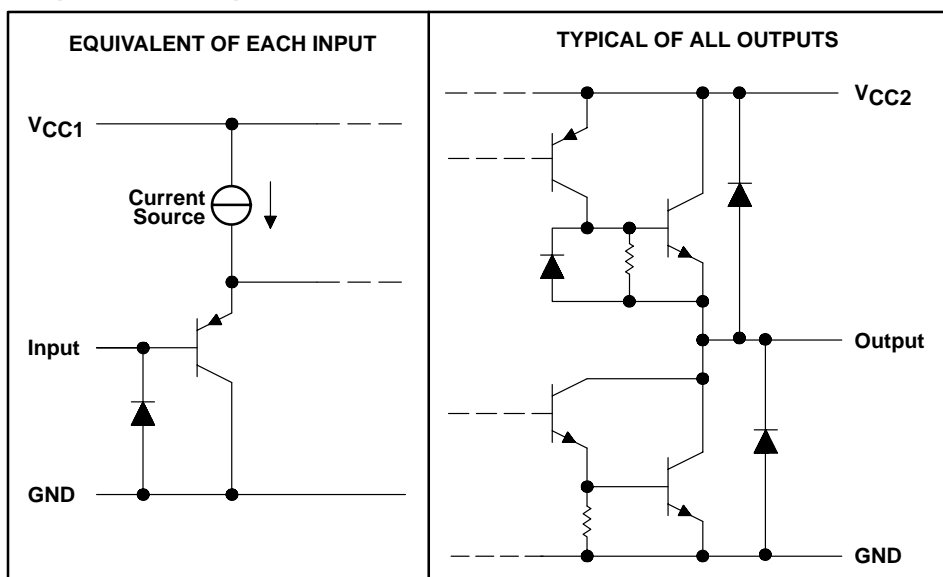

absolute maximum ratings over operating free-air temperature range (unless otherwise noted)

Logic supply voltage range, V_{CC1} (see Note 1)	36 V
Output supply voltage range, V_{CC2}	36 V
Input voltage range, V_I	7 V
Output voltage range, V_O	-3 V to $V_{CC2} + 3$ V
Peak output current (nonrepetitive, $t \leq 100 \mu\text{s}$)	± 1.2 A
Continuous output current, I_O	± 600 mA
Continuous total dissipation at (or below) 25°C free-air temperature (see Notes 2 and 3)	2075 mW
Continuous total dissipation at 80°C case temperature (see Note 3)	5000 mW
Operating case or virtual junction temperature range, T_J	-40°C to 150°C
Storage temperature range, T_{stg}	-65°C to 150°C
Lead temperature 1,6 mm (1/16 inch) from case for 10 seconds	260°C

- NOTES: 1. All voltage values are with respect to the network ground terminal.
 2. For operation above 25°C free-air temperature, derate linearly at the rate of 16.6 mW/°C.
 3. For operation above 25°C case temperature, derate linearly at the rate of 71.4 mW/°C. Due to variations in individual device electrical characteristics and thermal resistance, the built-in thermal overload protection may be activated at power levels slightly above or below the rated dissipation.

recommended operating conditions

		MIN	MAX	UNIT
Logic supply voltage, V_{CC1}		4.5	7	V
Output supply voltage, V_{CC2}		V_{CC1}	36	V
High-level input voltage, V_{IH}	$V_{CC1} \leq 7$ V	2.3	V_{CC1}	V
	$V_{CC1} \geq 7$ V	2.3	7	
Low-level input voltage, V_{IL}		-0.3†	1.5	V
Operating free-air temperature, T_A		0	70	°C

† The algebraic convention, in which the least positive (most negative) value is designated minimum, is used in this data sheet for logic voltage levels.

electrical characteristics, $V_{CC1} = 5\text{ V}$, $V_{CC2} = 24\text{ V}$, $T_A = 25^\circ\text{C}$

PARAMETER		TEST CONDITIONS	MIN	TYP	MAX	UNIT
V_{OH}	High-level output voltage	$I_{OH} = -0.6\text{ A}$	$V_{CC2} - 1.8$	$V_{CC2} - 1.4$		V
V_{OL}	Low-level output voltage	$I_{OL} = 0.6\text{ A}$		1.2	1.8	V
V_{OKH}	High-level output clamp voltage	$I_{OK} = -0.6\text{ A}$		$V_{CC2} + 1.3$		V
V_{OKL}	Low-level output clamp voltage	$I_{OK} = -0.6\text{ A}$		1.3		V
I_{IH}	High-level input current	A	$V_I = 7\text{ V}$	0.2	100	μA
		EN		0.2	± 10	
I_{IL}	Low-level input current	A	$V_I = 0$	-3	-10	μA
		EN		-2	-100	
I_{CC1}	Logic supply current	$I_O = 0$	All outputs at high level	13	22	mA
			All outputs at low level	35	60	
			All outputs at high impedance	8	24	
I_{CC2}	Output supply current	$I_O = 0$	All outputs at high level	14	24	mA
			All outputs at low level	2	6	
			All outputs at high impedance	2	4	

switching characteristics, $V_{CC1} = 5\text{ V}$, $V_{CC2} = 24\text{ V}$, $T_A = 25^\circ\text{C}$

PARAMETER	TEST CONDITIONS	MIN	TYP	MAX	UNIT
t_{PLH}	Propagation delay time, low-to-high-level output from A input		800		ns
t_{PHL}	Propagation delay time, high-to-low-level output from A input		400		ns
t_{TLH}	Transition time, low-to-high-level output		300		ns
t_{THL}	Transition time, high-to-low-level output		300		ns

$C_L = 30\text{ pF}$, See Figure 1

PARAMETER MEASUREMENT INFORMATION

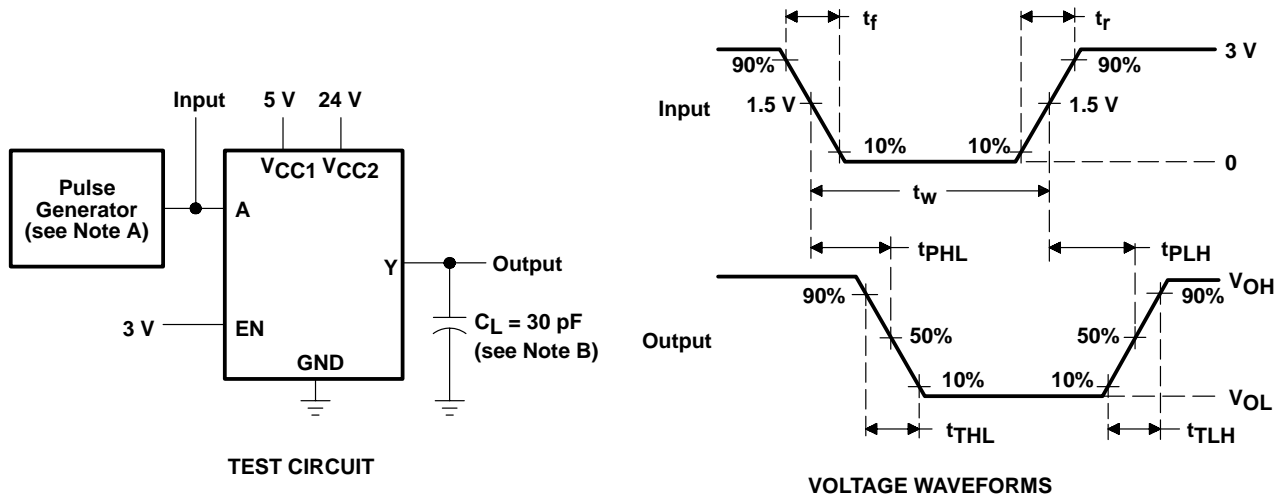

NOTES: A. The pulse generator has the following characteristics: $t_r \leq 10\text{ ns}$, $t_f \leq 10\text{ ns}$, $t_w = 10\text{ }\mu\text{s}$, $\text{PRR} = 5\text{ kHz}$, $Z_O = 50\text{ }\Omega$.
 B. C_L includes probe and jig capacitance.

Figure 1. Test Circuit and Voltage Waveforms

L293D QUADRUPLE HALF-H DRIVER

SLRS008A – SEPTEMBER 1986 – REVISED MAY 1990

APPLICATION INFORMATION

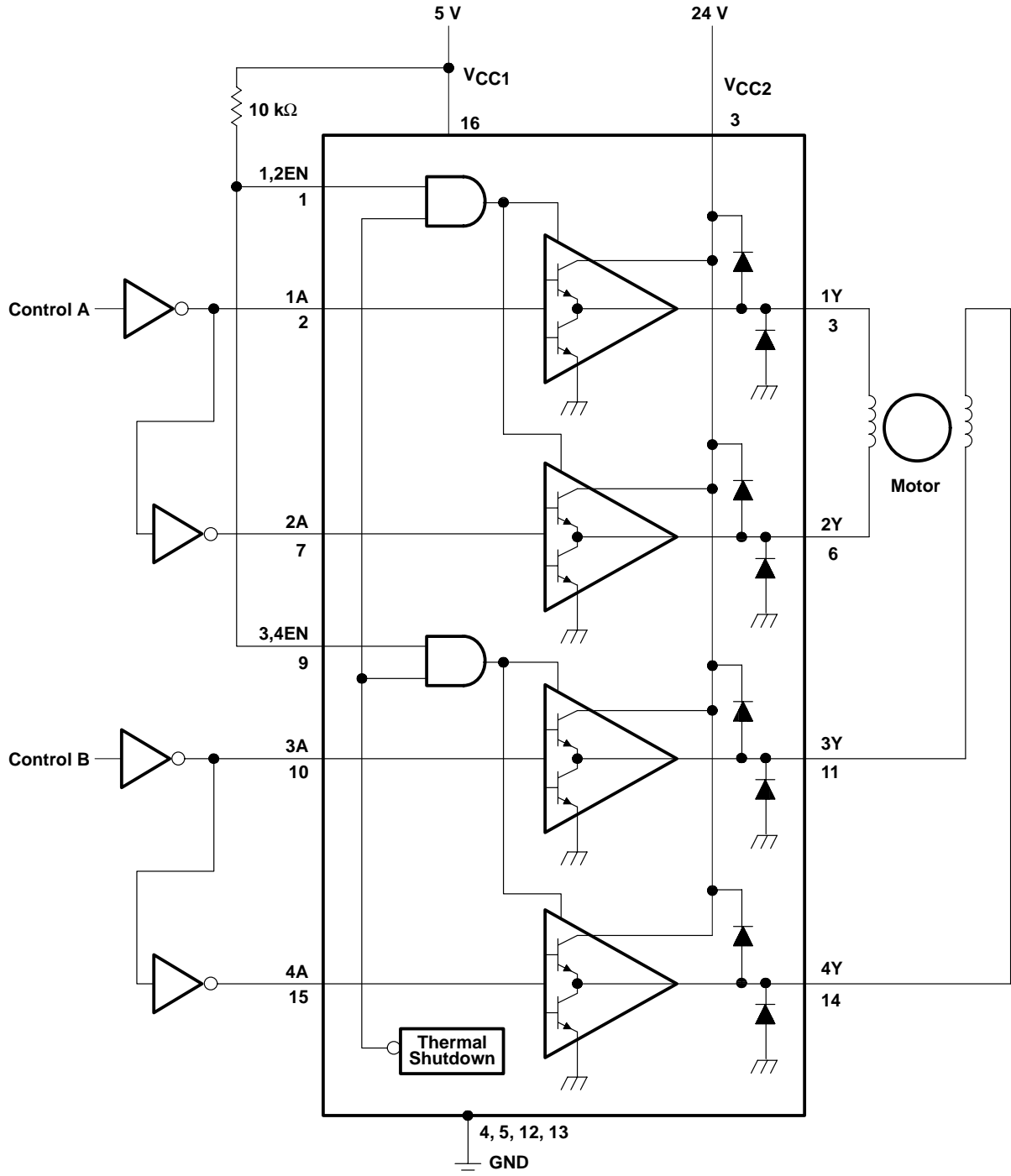

Figure 2. Two-Phase Motor Driver

IMPORTANT NOTICE

Texas Instruments (TI) reserves the right to make changes to its products or to discontinue any semiconductor product or service without notice, and advises its customers to obtain the latest version of relevant information to verify, before placing orders, that the information being relied on is current.

TI warrants performance of its semiconductor products and related software to the specifications applicable at the time of sale in accordance with TI's standard warranty. Testing and other quality control techniques are utilized to the extent TI deems necessary to support this warranty. Specific testing of all parameters of each device is not necessarily performed, except those mandated by government requirements.

Certain applications using semiconductor products may involve potential risks of death, personal injury, or severe property or environmental damage ("Critical Applications").

TI SEMICONDUCTOR PRODUCTS ARE NOT DESIGNED, INTENDED, AUTHORIZED, OR WARRANTED TO BE SUITABLE FOR USE IN LIFE-SUPPORT APPLICATIONS, DEVICES OR SYSTEMS OR OTHER CRITICAL APPLICATIONS.

Inclusion of TI products in such applications is understood to be fully at the risk of the customer. Use of TI products in such applications requires the written approval of an appropriate TI officer. Questions concerning potential risk applications should be directed to TI through a local SC sales office.

In order to minimize risks associated with the customer's applications, adequate design and operating safeguards should be provided by the customer to minimize inherent or procedural hazards.

TI assumes no liability for applications assistance, customer product design, software performance, or infringement of patents or services described herein. Nor does TI warrant or represent that any license, either express or implied, is granted under any patent right, copyright, mask work right, or other intellectual property right of TI covering or relating to any combination, machine, or process in which such semiconductor products or services might be or are used.