

LT1004C-1.2, LT1004C-2.5, LT1004I-1.2, LT1004I-2.5, LT1004M-1.2 LT1004M-2.5, LT1004Y-1.2, LT1004Y-2.5 MICROPOWER INTEGRATED VOLTAGE REFERENCES

SLVS022F – JANUARY 1989 – REVISED MARCH 1998

- **Initial Accuracy**
 ± 4 mV for LT1004-1.2
 ± 20 mV for LT1004-2.5
- **Micropower Operation**
- **Operates up to 20 mA**
- **Very Low Reference Impedance**
- **Applications:**
Portable Meter Reference
Portable Test Instruments
Battery-Operated Systems
Current-Loop Instrumentation

**D PACKAGE
(TOP VIEW)**

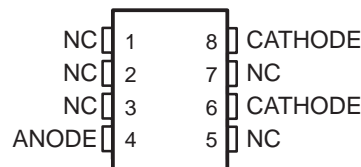

Terminals 6 and 8 are internally connected.

**LP PACKAGE
(TOP VIEW)**

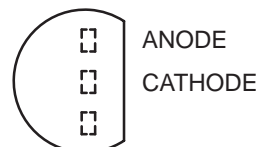

NC—No internal connection

description

The LT1004 micropower voltage reference is a two-terminal band-gap reference diode designed to provide high accuracy and excellent temperature characteristics at very low operating currents. Optimizing the key parameters in the design, processing, and testing of the device results in specifications previously attainable only with selected units.

symbol

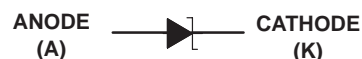

The LT1004 is a pin-for-pin replacement for the LM185 series of references with improved specifications. The LT1004 is an excellent device for use in systems in which accuracy was previously attained at the expense of power consumption and trimming.

The LT1004C is characterized for operation from 0°C to 70°C. The LT1004I is characterized for operation from -40°C to 85°C. The LT1004M is characterized for operation over the full military temperature range of -55°C to 125°C.

AVAILABLE OPTIONS†

T _A	PACKAGED DEVICES‡			CHIP FORM (Y)
	V _Z TYP	SMALL-OUTLINE (D)	PLASTIC (LP)	
0°C to 70°C	1.2 V	LT1004CD-1.2	LT1004CLP-1.2	LT1004Y-1.2
	2.5 V	LT1004CD-2.5	LT1004CLP-2.5	LT1004Y-2.5
-40°C to 85°C	1.2 V	LT1004ID-1.2	LT1004ILP-1.2	—
	2.5 V	LT1004ID-2.5	LT1004ILP-2.5	
-55°C to 125°C	1.2 V	LT1004MD-1.2	LT1004MLP-1.2	—
	2.5 V	LT1004MD-2.5	LT1004MLP-2.5	

† For ordering purposes, the decimal point in the part number must be replaced with a hyphen (e.g., show the -1.2 suffix as -1-2 and the -2.5 suffix as -2-5).

‡ The packages are available taped and reeled. Add the R suffix to the device type (e.g., LT1004CDR).



Please be aware that an important notice concerning availability, standard warranty, and use in critical applications of Texas Instruments semiconductor products and disclaimers thereto appears at the end of this data sheet.

PRODUCTION DATA information is current as of publication date. Products conform to specifications per the terms of Texas Instruments standard warranty. Production processing does not necessarily include testing of all parameters.

**TEXAS
INSTRUMENTS**

POST OFFICE BOX 655303 • DALLAS, TEXAS 75265

Copyright © 1998, Texas Instruments Incorporated

LT1004C-1.2, LT1004C-2.5, LT1004I-1.2, LT1004I-2.5, LT1004M-1.2
 LT1004M-2.5, LT1004Y-1.2, LT1004Y-2.5
MICROPOWER INTEGRATED VOLTAGE REFERENCES

SLVS022F – JANUARY 1989 – REVISED MARCH 1998

schematic

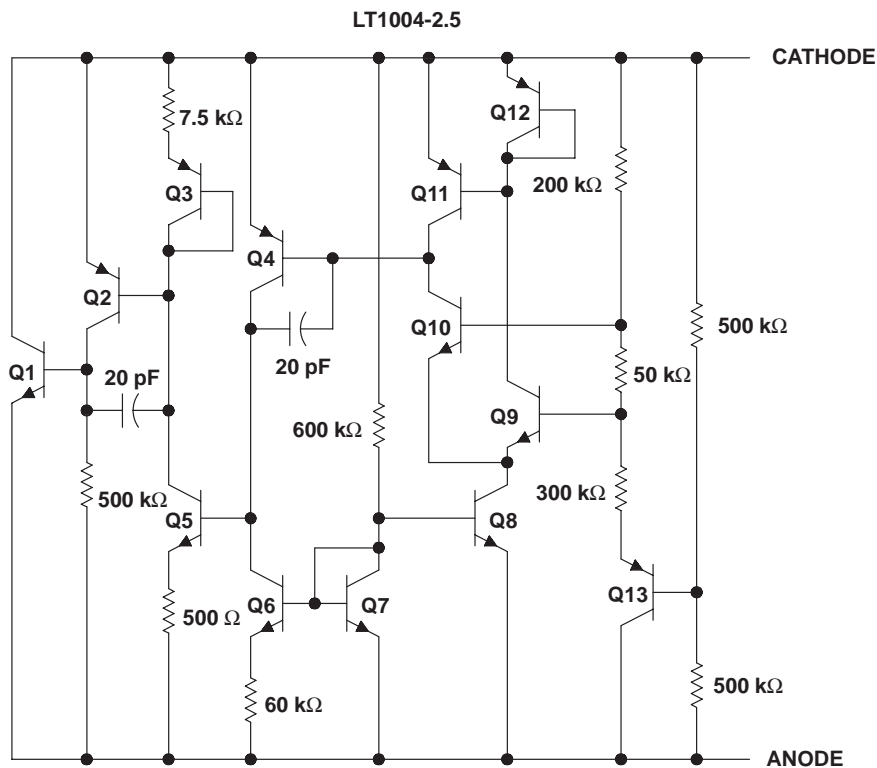
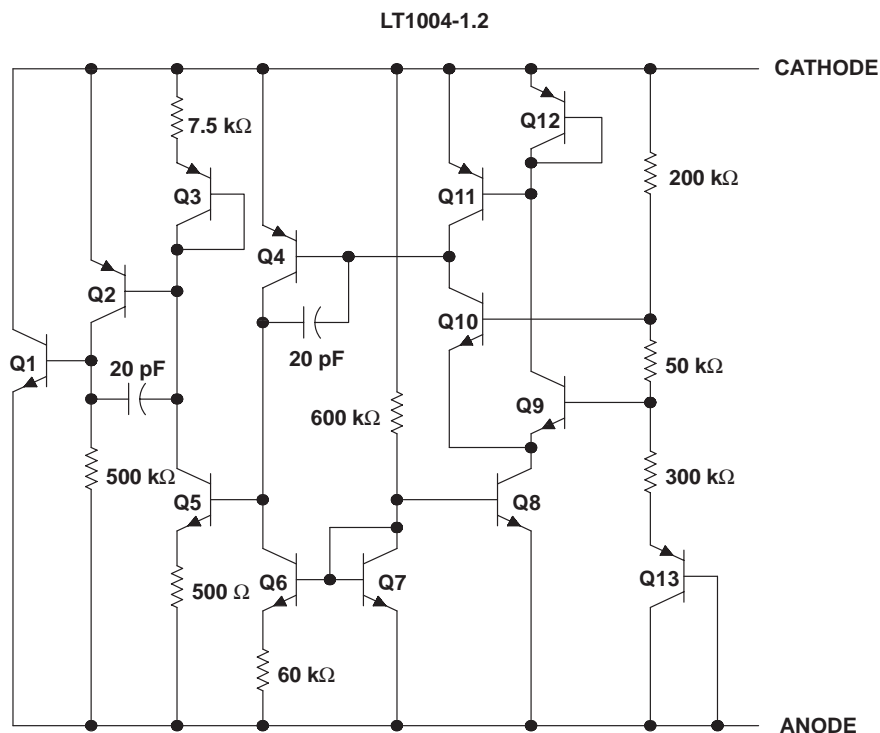

NOTE A: All component values shown are nominal.



POST OFFICE BOX 655303 • DALLAS, TEXAS 75265

LT1004C-1.2, LT1004C-2.5, LT1004I-1.2, LT1004I-2.5, LT1004M-1.2
 LT1004M-2.5, LT1004Y-1.2, LT1004Y-2.5

MICROPOWER INTEGRATED VOLTAGE REFERENCES

SLVS022F – JANUARY 1989 – REVISED MARCH 1998

electrical characteristics at specified free-air temperature

PARAMETER	TEST CONDITIONS	T _A †	LT1004-1.2			LT1004-2.5			UNIT
			MIN	TYP	MAX	MIN	TYP	MAX	
V _Z Reference voltage	I _Z = 100 μA	25°C	1.231	1.235	1.239	2.48	2.5	2.52	V
		Full range	LT1004C	1.225	1.245	2.47	2.53		
			LT1004I	1.225	1.245	2.47	2.53		
			LT1004M	1.215	1.245	2.46	2.535		
α _{VZ} Average temperature coefficient of reference voltage‡	I _Z = 10 μA	25°C	20						ppm/°C
	I _Z = 20 μA					20			
ΔV _Z Change in reference voltage with current	I _Z = I _{Zmin} to 1 mA	25°C	1			1			mV
		Full range	1.5			1.5			
	I _Z = 1 mA to 20 mA	25°C	10			10			
		Full range	20			20			
ΔV _Z /Δt Long term change in reference voltage	I _Z = 100 μA	25°C	20			20			ppm/chr
I _{Zmin} Minimum reference current		Full range	8 10			12 20			μA
z _Z Reference impedance	I _Z = 100 μA	25°C	0.2 0.6			0.2 0.6			Ω
		Full range	1.5			1.5			
V _n Broadband noise voltage	I _Z = 100 μA, f = 10 Hz to 10 kHz	25°C	60			120			μV

† Full range is 0°C to 70°C for the LT1004C, -40°C to 85°C for LT1004I, and -55°C to 125°C for the LT1004M.

‡ The average temperature coefficient of reference voltage is defined as the total change in reference voltage divided by the specified temperature range.

electrical characteristics, T_A = 25°C

PARAMETER	TEST CONDITIONS	LT1004Y-1.2			LT1004Y-2.5			UNIT
		MIN	TYP	MAX	MIN	TYP	MAX	
V _Z Reference voltage	I _Z = 100 μA	1.231	1.235	1.239	2.48	2.5	2.52	V
α _{VZ} Average temperature coefficient of reference voltage†	I _Z = 10 μA	20						ppm/°C
	I _Z = 20 μA				20			
ΔV _Z /Δt Long-term change in reference voltage	I _Z = 100 μA	20			20			ppm/chr
I _{Zmin} Minimum reference current		8			12			μA
z _Z Reference impedance	I _Z = 100 μA	0.2 0.6			0.2 0.6			Ω
V _n Broadband noise voltage	I _Z = 100 μA, f = 10 Hz to 10 kHz	60			120			μV

† The average temperature coefficient of reference voltage is defined as the total change in reference voltage divided by the specified temperature range.



TYPICAL CHARACTERISTICS†

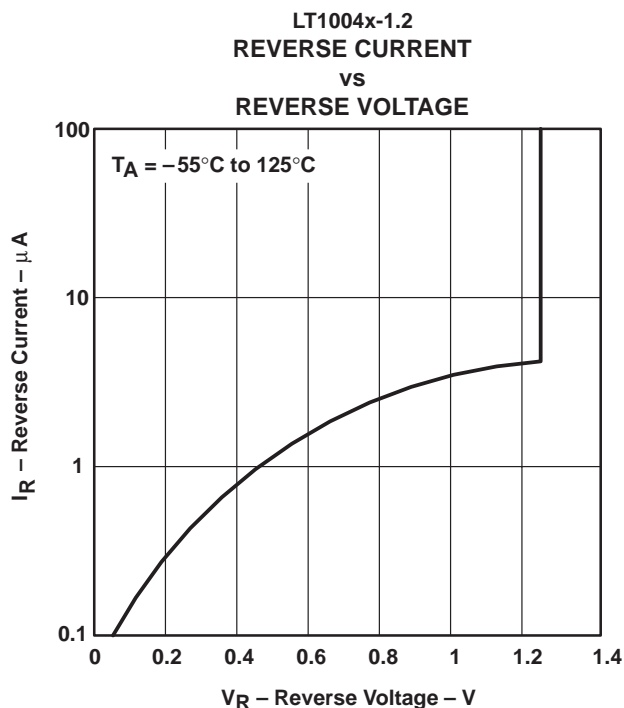

Figure 1

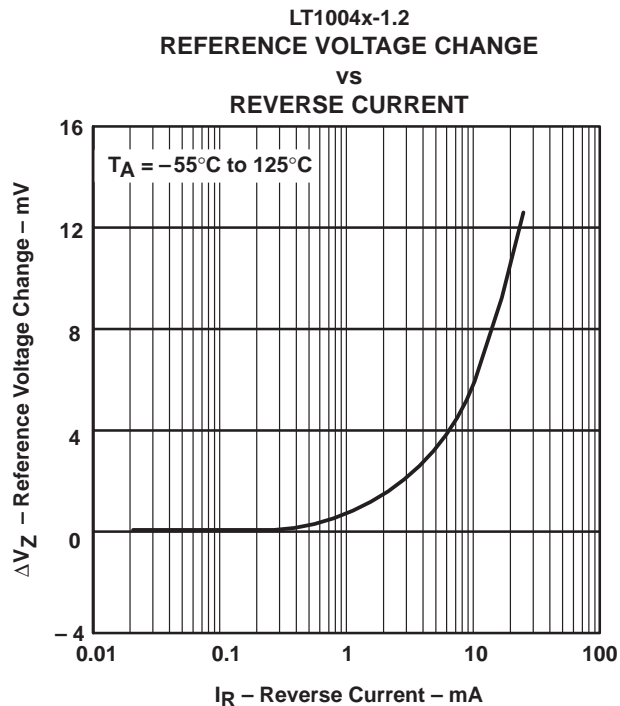

Figure 2

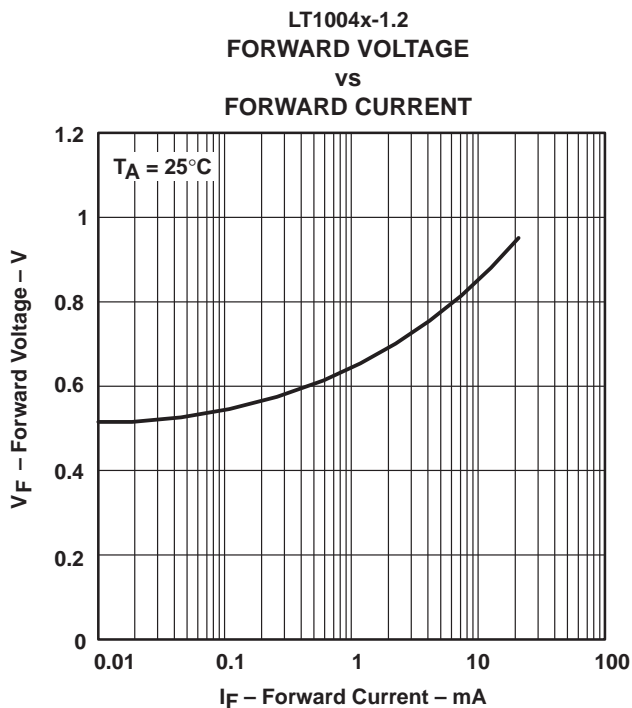

Figure 3

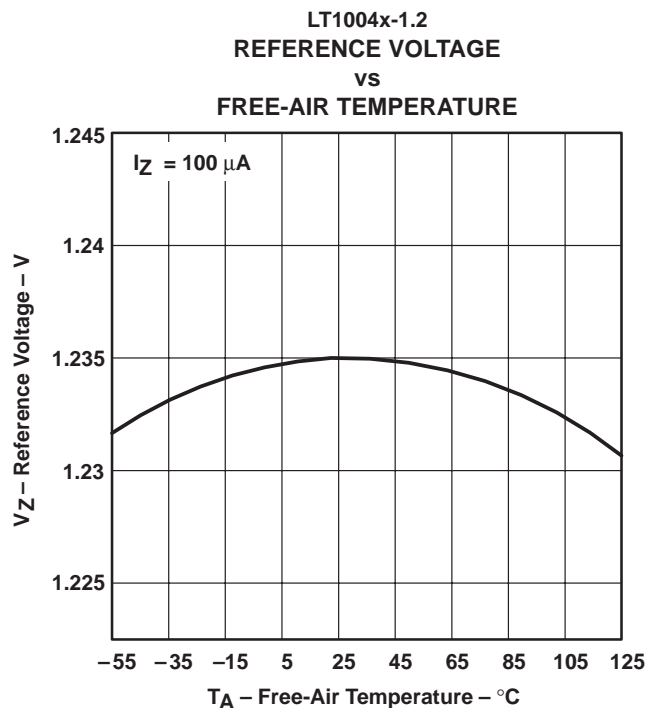

Figure 4

† Data at high and low temperatures are applicable only within the rated operating free-air temperature ranges of the various devices.

TYPICAL CHARACTERISTICS†

LT1004x-1.2
REFERENCE IMPEDANCE
 VS
REFERENCE CURRENT

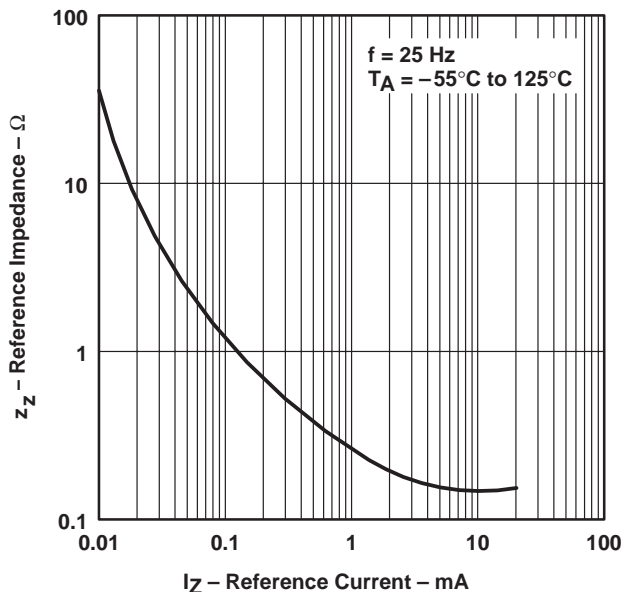

Figure 5

LT1004x-1.2
NOISE VOLTAGE
 VS
FREQUENCY

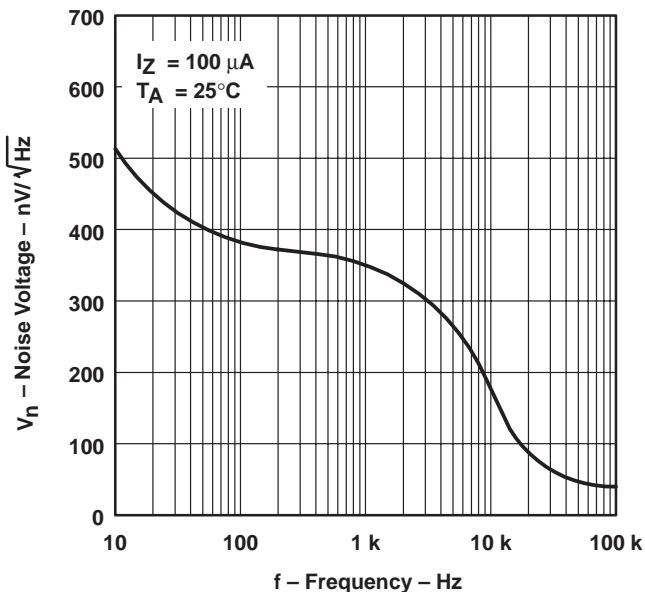

Figure 6

LT1004x-1.2
FILTERED OUTPUT NOISE VOLTAGE
 VS
CUTOFF FREQUENCY

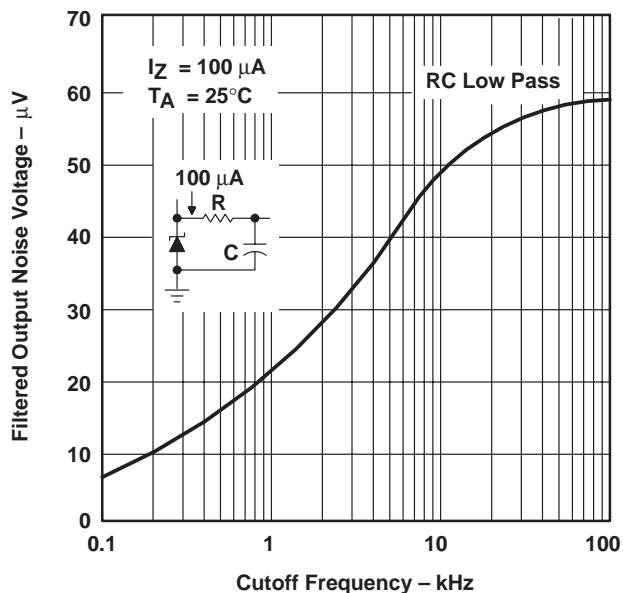

Figure 7

LT1004x-2.5
TRANSIENT RESPONSE

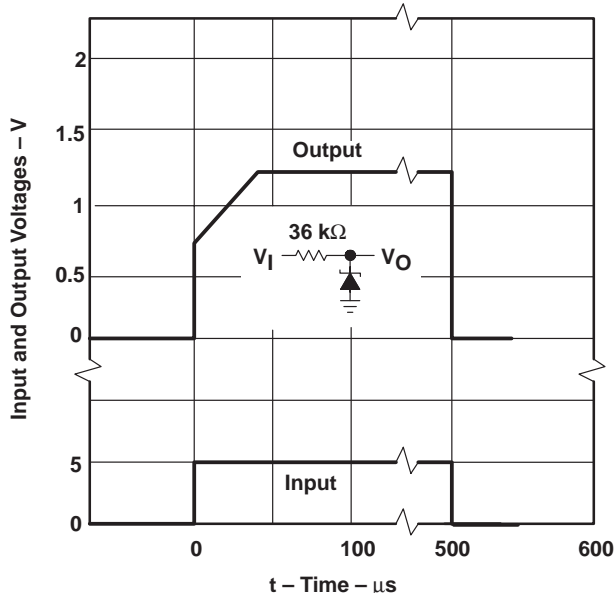

Figure 8

† Data at high and low temperatures are applicable only within the rated operating free-air temperature ranges of the various devices.

TYPICAL CHARACTERISTICS†

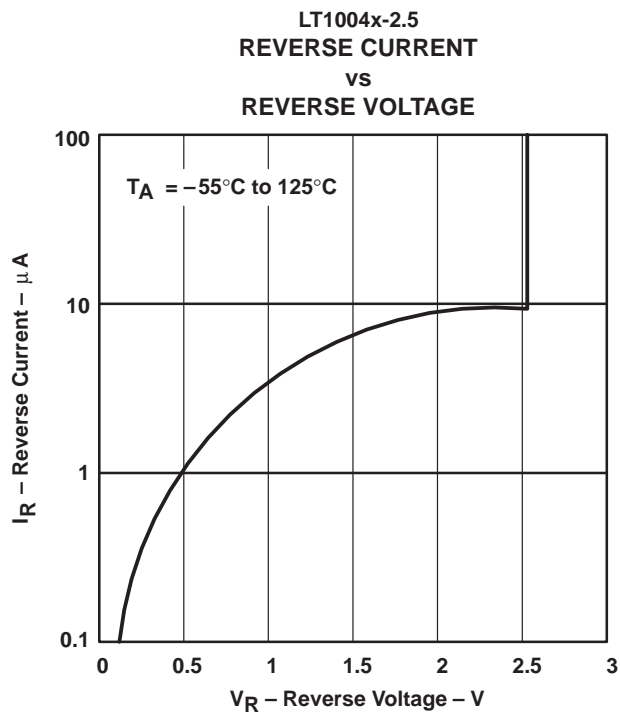

Figure 9

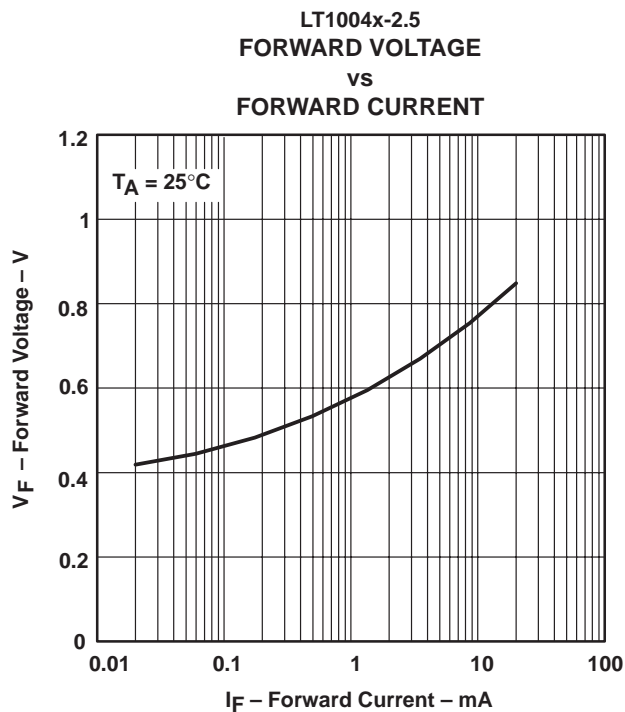

Figure 10

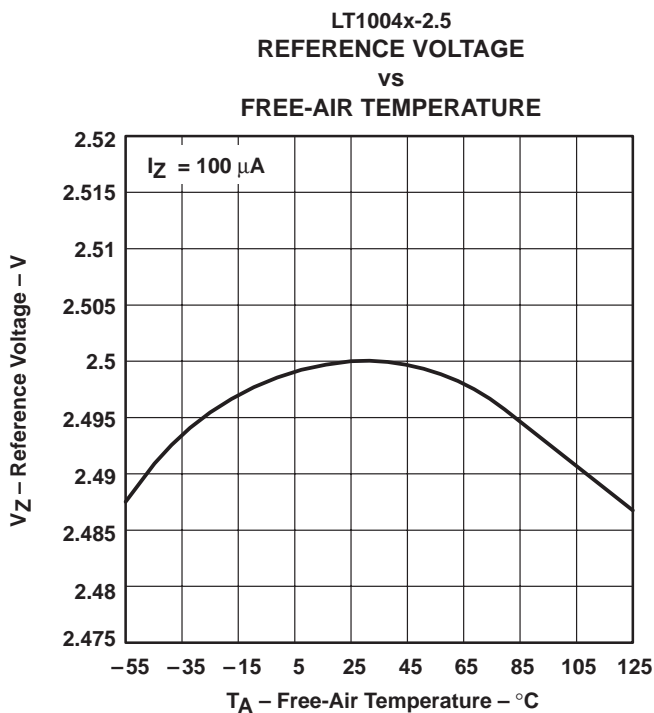

Figure 11

† Data at high and low temperatures are applicable only within the rated operating free-air temperature ranges of the various devices.

TYPICAL CHARACTERISTICS†

**LT1004x-2.5
 REFERENCE IMPEDANCE
 vs
 REFERENCE CURRENT**

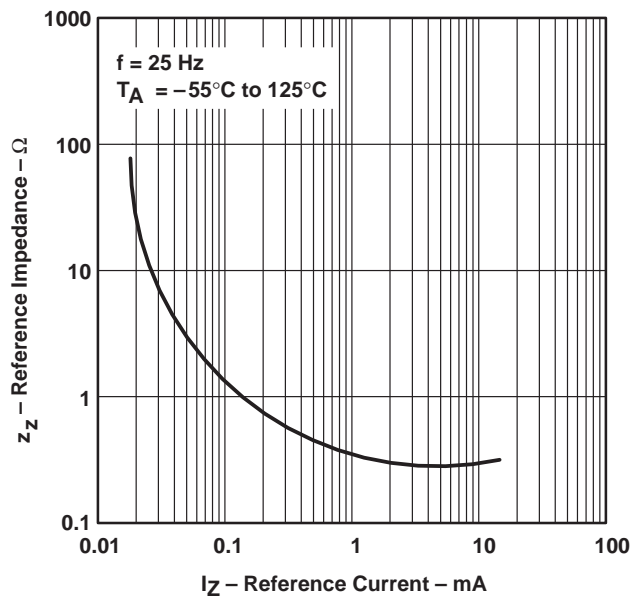

Figure 12

**LT1004x-2.5
 NOISE VOLTAGE
 vs
 FREQUENCY**

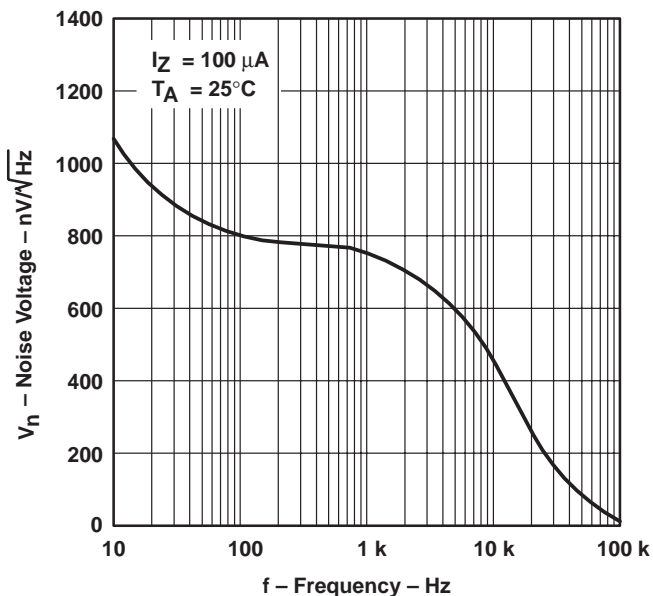

Figure 13

**TL1004x-2.5
 FILTERED OUTPUT NOISE VOLTAGE
 vs
 CUTOFF FREQUENCY**

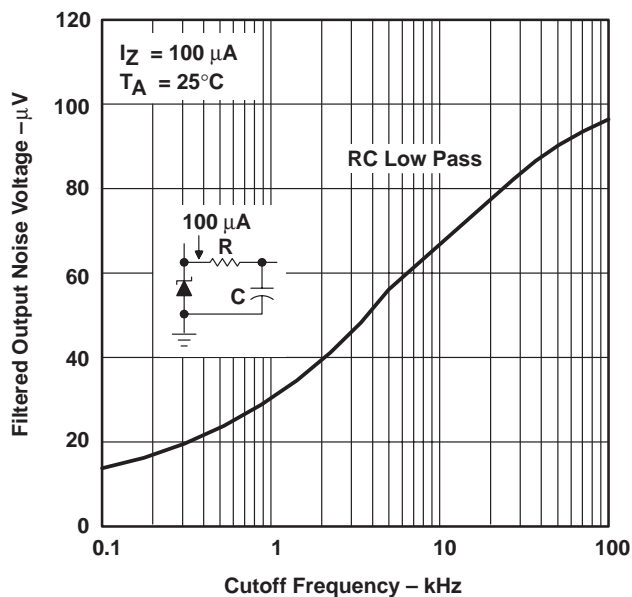

Figure 14

**LT1004x-2.5
 TRANSIENT RESPONSE**

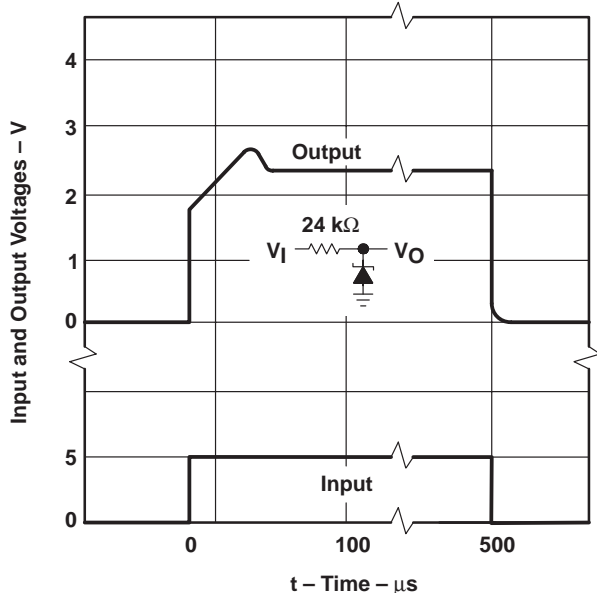

Figure 15

† Data at high and low temperatures are applicable only within the rated operating free-air temperature ranges of the various devices.

APPLICATION INFORMATION

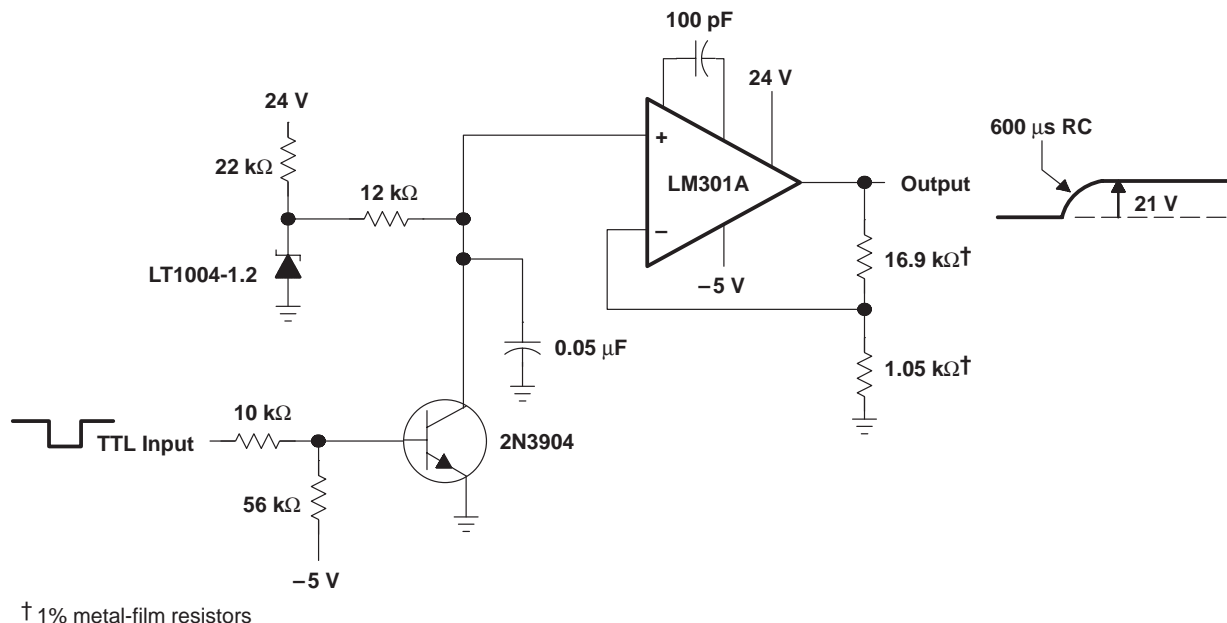

Figure 16. $V_{I(PP)}$ Generator for EPROMs (No Trim Required)

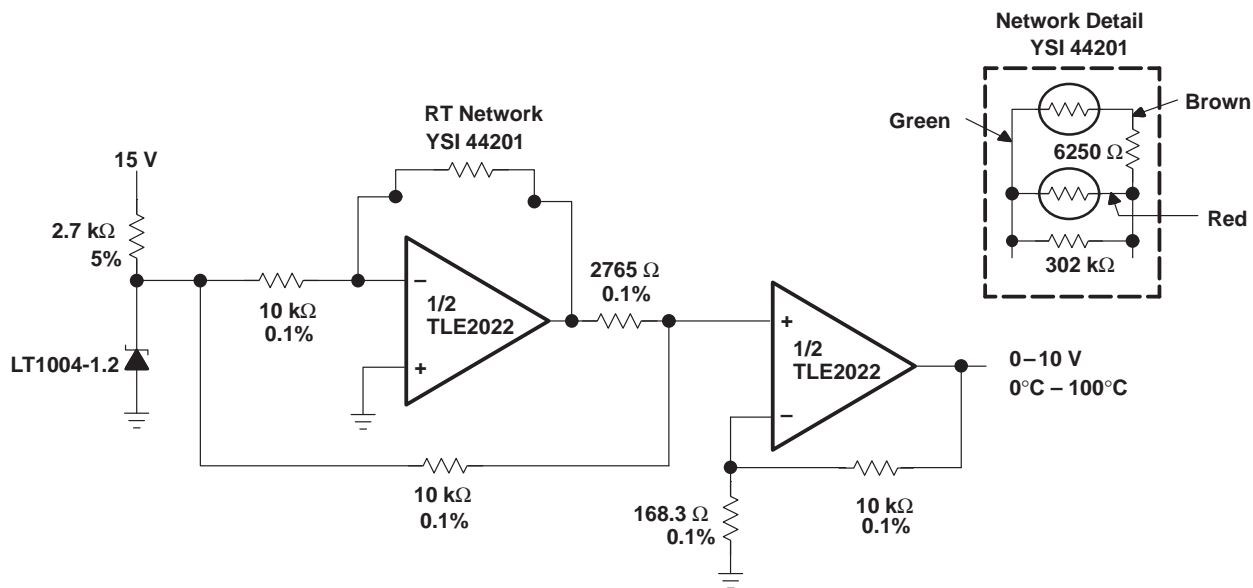

Figure 17. 0°C to 100°C Linear Output Thermometer

APPLICATION INFORMATION

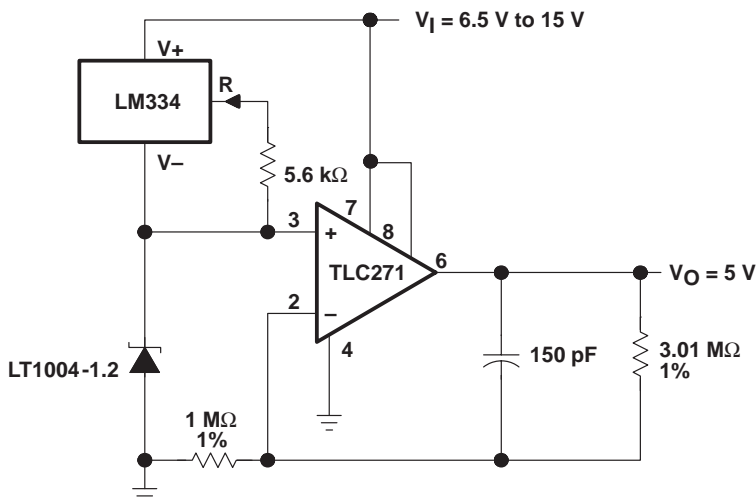

Figure 18. Micropower 5-V Reference

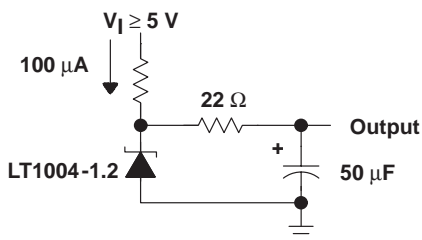

Figure 19. Low-Noise Reference

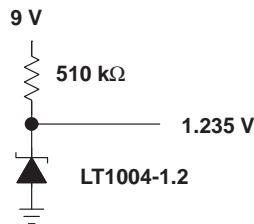
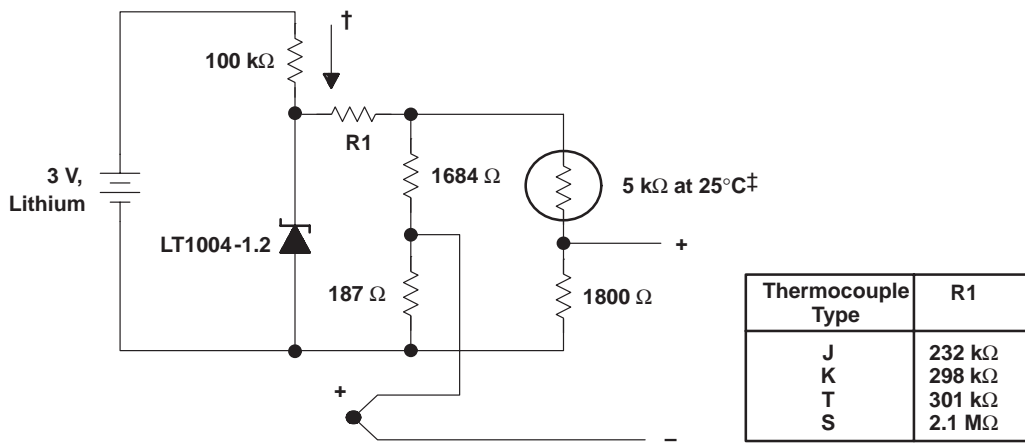

Figure 20. Micropower Reference From 9-V Battery



† Quiescent current $\cong 15 \mu\text{A}$

‡ Yellow Springs Inst. Co., Part #44007

NOTE A: This application compensates within $\pm 1^\circ\text{C}$ from 0°C to 60°C .

Figure 21. Micropower Cold-Junction Compensation for Thermocouples

APPLICATION INFORMATION

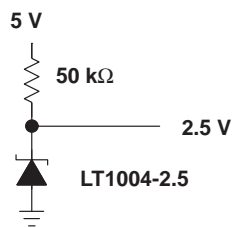

Figure 22. 2.5-V Reference

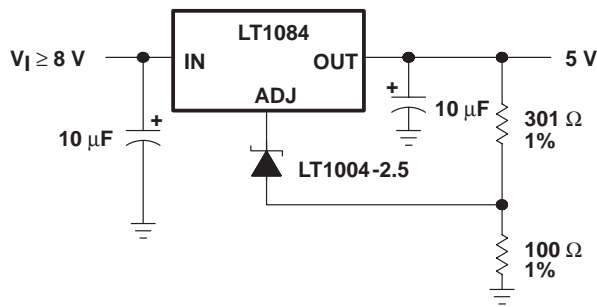
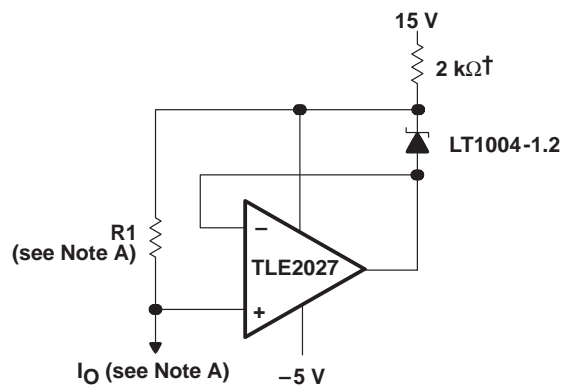

Figure 23. High-Stability 5-V Regulator



† May be increased for small output currents
 NOTE A: $R1 \approx \frac{2V}{I_O + 10\mu A}$, $I_O = \frac{1.235V}{R1}$

Figure 24. Ground-Referenced Current Source

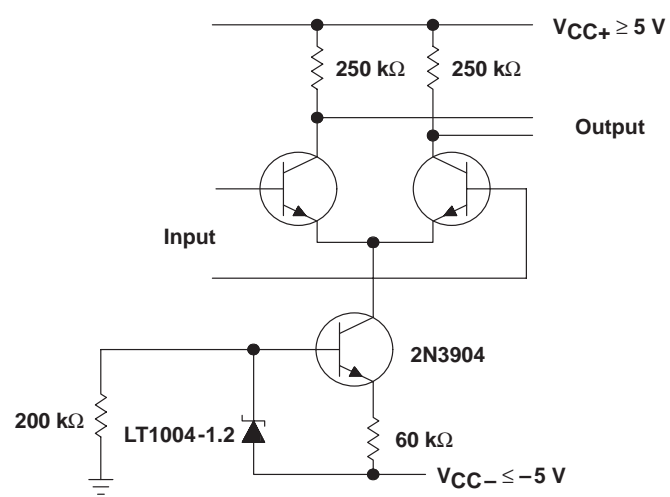
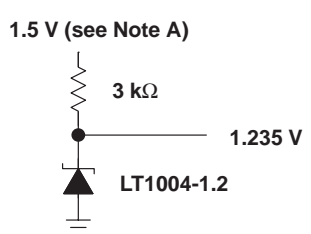

Figure 25. Amplifier With Constant Gain Over Temperature



NOTE A: Output regulates down to 1.285 V for $I_O = 0$.

Figure 26. 1.2-V Reference form 1.5-V Battery

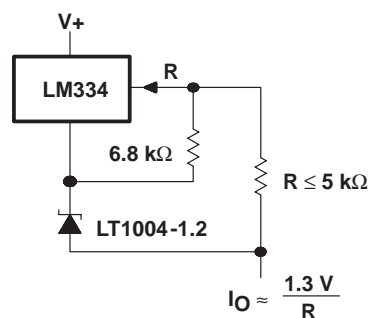
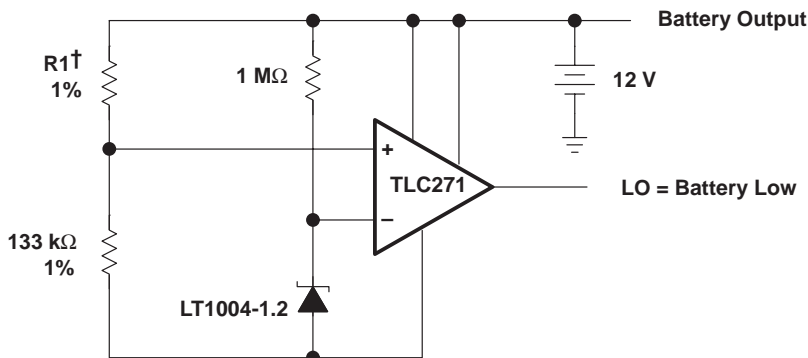

Figure 27. Terminal Current Source With Low Temperature Coefficient

APPLICATION INFORMATION



†R1 sets trip point, 60.4 kΩ per cell for 1.8 V per cell

Figure 28. Lead-Acid Low-Battery Voltage Detector

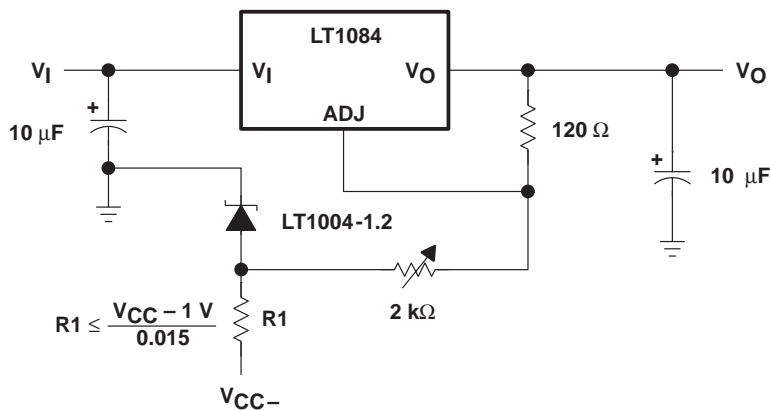

Figure 29. Variable Voltage Supply

LT1004C-1.2, LT1004C-2.5, LT1004I-1.2, LT1004I-2.5, LT1004M-1.2
 LT1004M-2.5, LT1004Y-1.2, LT1004Y-2.5
MICROPOWER INTEGRATED VOLTAGE REFERENCES

SLVS022F – JANUARY 1989 – REVISED MARCH 1998

MECHANICAL DATA

D (R-PDSO-G)**

PLASTIC SMALL-OUTLINE PACKAGE

14 PIN SHOWN

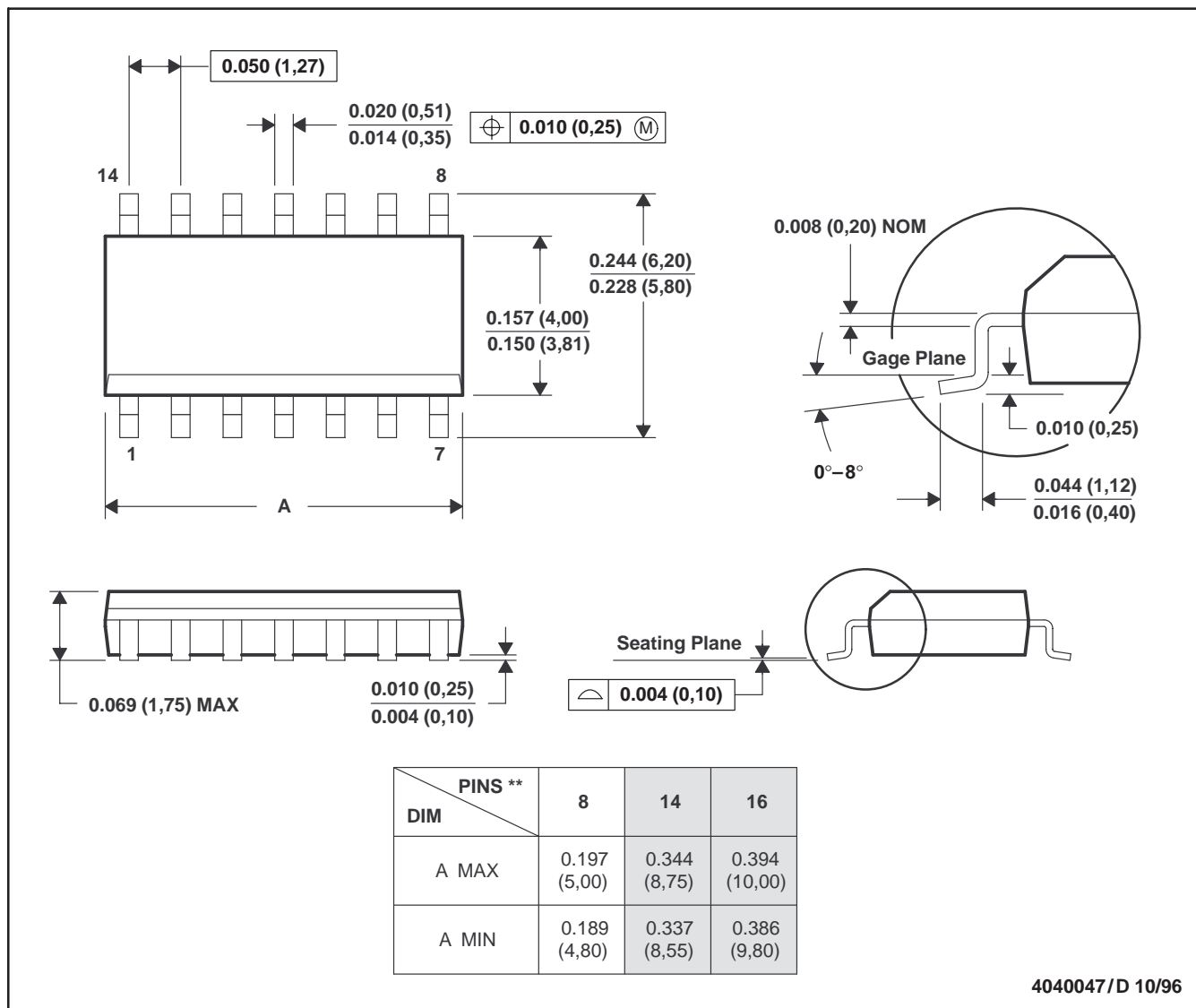

- NOTES: A. All linear dimensions are in inches (millimeters).
 B. This drawing is subject to change without notice.
 C. Body dimensions do not include mold flash or protrusion, not to exceed 0.006 (0,15).
 D. Falls within JEDEC MS-012

MECHANICAL DATA

LP (O-PBCY-W3)

PLASTIC CYLINDRICAL PACKAGE

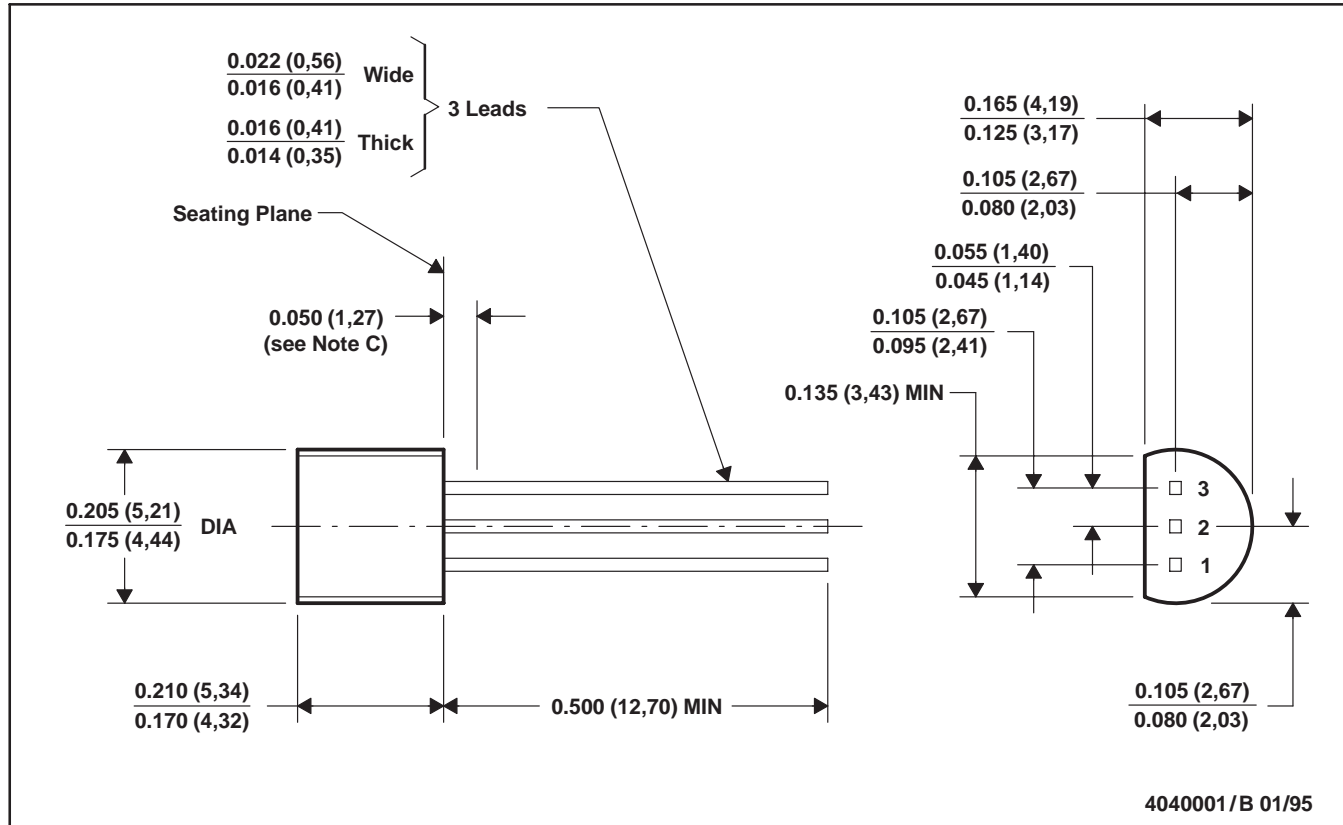

- NOTES: A. All linear dimensions are in inches (millimeters).
 B. This drawing is subject to change without notice.
 C. Lead dimensions are not controlled within this area.
 D. Falls within JEDEC TO-226AA (TO-226AA replaces TO-92)

IMPORTANT NOTICE

Texas Instruments (TI) reserves the right to make changes to its products or to discontinue any semiconductor product or service without notice, and advises its customers to obtain the latest version of relevant information to verify, before placing orders, that the information being relied on is current and complete.

TI warrants performance of its semiconductor products and related software to the specifications applicable at the time of sale in accordance with TI's standard warranty. Testing and other quality control techniques are utilized to the extent TI deems necessary to support this warranty. Specific testing of all parameters of each device is not necessarily performed, except those mandated by government requirements.

Certain applications using semiconductor products may involve potential risks of death, personal injury, or severe property or environmental damage ("Critical Applications").

TI SEMICONDUCTOR PRODUCTS ARE NOT DESIGNED, INTENDED, AUTHORIZED, OR WARRANTED TO BE SUITABLE FOR USE IN LIFE-SUPPORT APPLICATIONS, DEVICES OR SYSTEMS OR OTHER CRITICAL APPLICATIONS.

Inclusion of TI products in such applications is understood to be fully at the risk of the customer. Use of TI products in such applications requires the written approval of an appropriate TI officer. Questions concerning potential risk applications should be directed to TI through a local SC sales office.

In order to minimize risks associated with the customer's applications, adequate design and operating safeguards should be provided by the customer to minimize inherent or procedural hazards.

TI assumes no liability for applications assistance, customer product design, software performance, or infringement of patents or services described herein. Nor does TI warrant or represent that any license, either express or implied, is granted under any patent right, copyright, mask work right, or other intellectual property right of TI covering or relating to any combination, machine, or process in which such semiconductor products or services might be or are used.