

# TL7702A, TL7705A, TL7709A, TL7712A, TL7715A TL7702AY, TL7705AY, TL7709AY, TL7712AY, TL7715AY SUPPLY VOLTAGE SUPERVISORS

SLVS028C – APRIL 1983 – REVISED AUGUST 1995

- Power-On Reset Generator
- Automatic Reset Generation After Voltage Drop
- Wide Supply Voltage Range
- Precision Voltage Sensor
- Temperature-Compensated Voltage Reference
- True and Complement Reset Outputs
- Externally Adjustable Pulse Duration

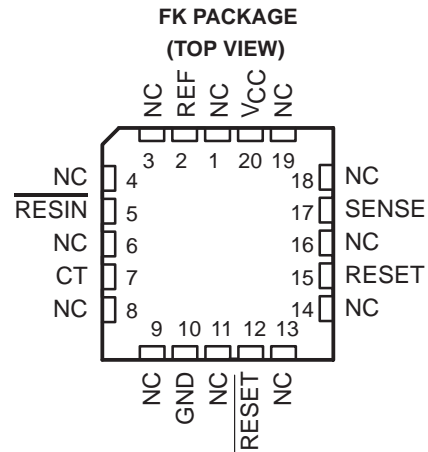
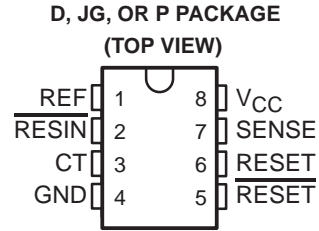

NC – No internal connection

## description

The TL77xxA family of monolithic integrated circuit supply voltage supervisors are specifically designed for use as reset controllers in micro-computer and microprocessor systems. The supply voltage supervisor monitors the supply for undervoltage conditions at the SENSE input. During power up, the  $\overline{\text{RESET}}$  output becomes active (low) when  $V_{CC}$  attains a value approaching 3.6 V. At this point (assuming that SENSE is above  $V_{IT+}$ ), the delay timer function activates a time delay after which outputs  $\overline{\text{RESET}}$  and RESET go inactive (high and low respectively). When an undervoltage condition occurs during normal operation, outputs  $\overline{\text{RESET}}$  and RESET go active. To ensure that a complete reset occurs, the reset outputs remain active for a time delay after the voltage at the SENSE input exceeds the positive-going threshold value. The time delay is determined by the value of the external capacitor  $C_T$ :  $t_d = 1.3 \times 10^4 \times C_T$ , where  $C_T$  is in farads (F) and  $t_d$  is in seconds (s).

During power down (assuming that SENSE is below  $V_{IT-}$ ), the outputs remain active until the  $V_{CC}$  falls below a maximum of 2 V. After this, the outputs are undefined.

An external capacitor (typically 0.1  $\mu\text{F}$  for the TL77xxAC and TL77xxAI and typically 0.02  $\mu\text{F}$  for the TL77xxAM) must be connected to REF to reduce the influence of fast transients in the supply voltage.

The TL77xxAC series are characterized for operation from 0°C to 70°C. The TL77xxAI series are characterized for operation from –40°C to 85°C. The TL7702AM and TL7705AM are characterized for operation over the full military range of –55°C to 125°C.

## AVAILABLE OPTIONS

T <sub>A</sub>	PACKAGED DEVICES				CHIP FORM (Y)
	SMALL OUTLINE (D)	CHIP CARRIER (FK)	CERAMIC DIP (JG)	PLASTIC DIP (P)	
0°C to 70°C	TL7702ACD – TL7715ACD			TL7702ACP – TL7715ACP	TL7702ACY – TL7715ACY
–40°C to 85°C	TL7702AID – TL7715AID			TL7702AIP – TL7715AIP	
–55°C to 125°C		TL7702AMFK TL7705AMFK	TL7702AMJG TL7705AMJG		

PRODUCTION DATA information is current as of publication date. Products conform to specifications per the terms of Texas Instruments standard warranty. Production processing does not necessarily include testing of all parameters.



POST OFFICE BOX 655303 • DALLAS, TEXAS 75265

Copyright © 1995, Texas Instruments Incorporated  
On products compliant to MIL-STD-883, Class B, all parameters are tested unless otherwise noted. On all other products, production processing does not necessarily include testing of all parameters.

TL7702A, TL7705A, TL7709A, TL7712A, TL7715A  
 TL7702AY, TL7705AY, TL7709AY, TL7712AY, TL7715AY  
**SUPPLY VOLTAGE SUPERVISORS**

SLVS028C – APRIL 1983 – REVISED AUGUST 1995

**TL77xxAY chip information**

This chip, when properly assembled, displays characteristics similar to the TL77xxAC. Thermal compression or ultrasonic bonding may be used on the doped aluminum bonding pads. The chips may be mounted with conductive epoxy or a gold-silicon preform.

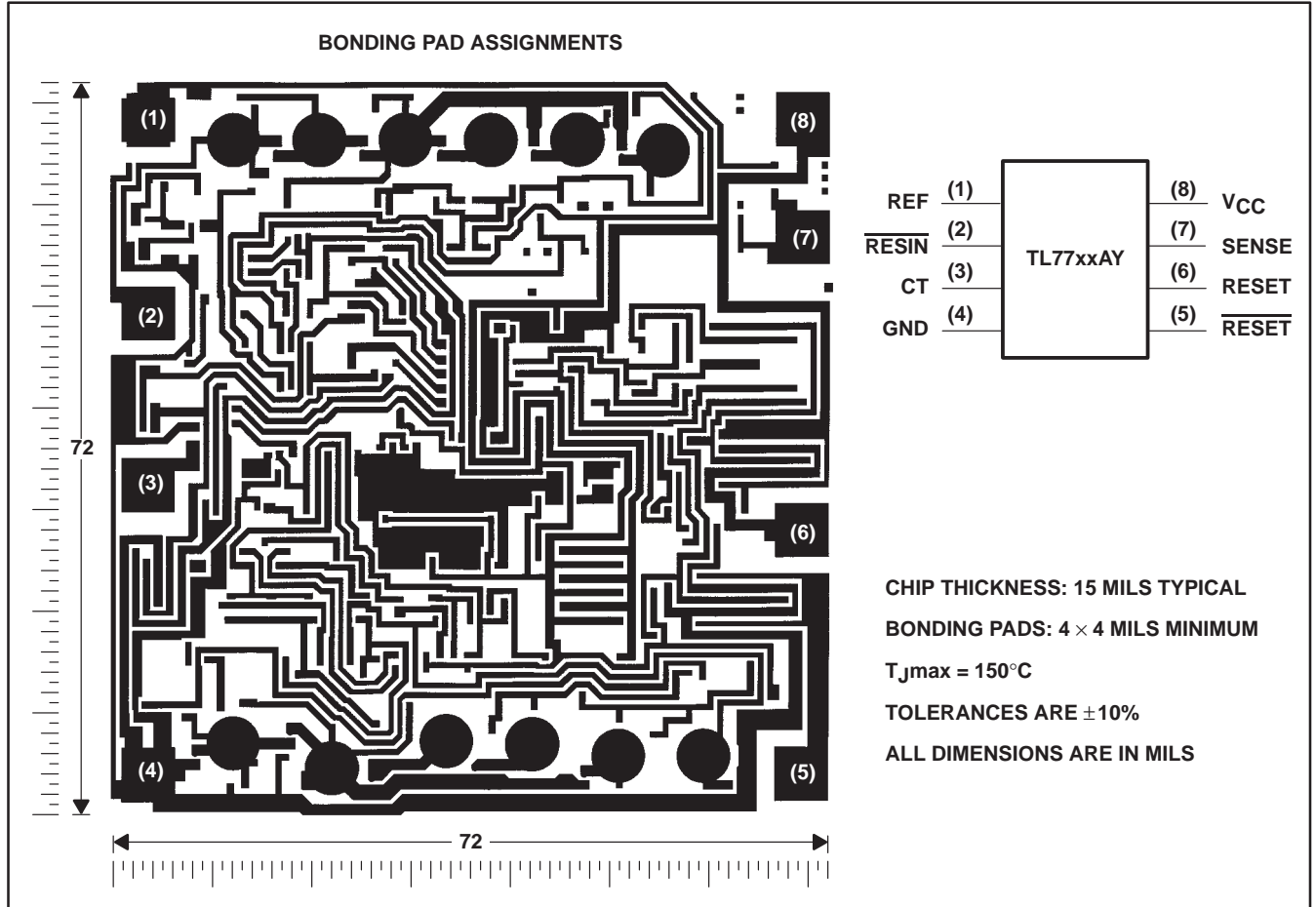

### functional block diagram

The functional block diagram is shown for illustrative purposes only; the actual circuit includes a trimming network to adjust the reference voltage and sense comparator trip point.

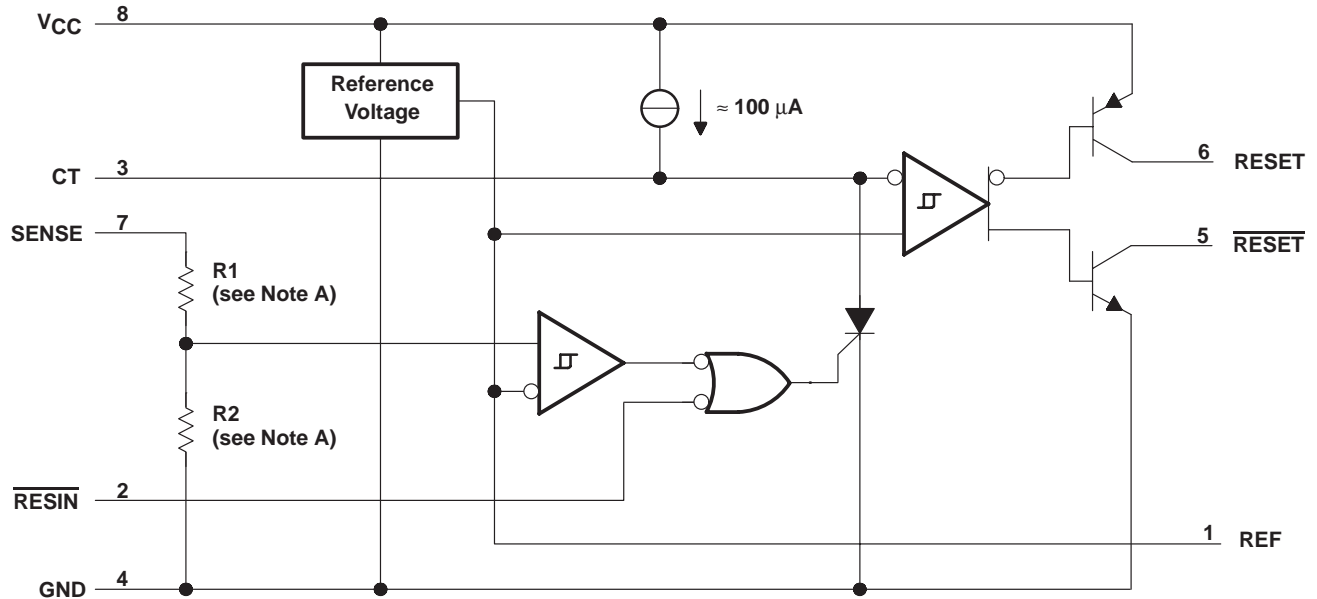

- NOTES: A. TL7702A: R1 = 0 Ω, R2 = open  
 TL7705A: R1 = 7.8 kΩ, R2 = 10 kΩ  
 TL7709A: R1 = 19.7 kΩ, R2 = 10 kΩ  
 TL7712A: R1 = 32.7 kΩ, R2 = 10 kΩ  
 TL7715A: R1 = 43.4 kΩ, R2 = 10 kΩ  
 B. Terminal numbers shown are for the D, JG, or P package.  
 C. Resistor values shown are nominal.

### timing diagram

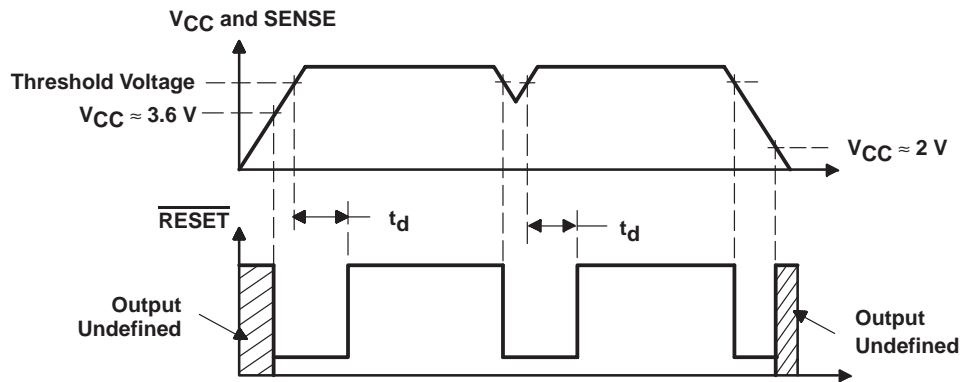

**TL7702A, TL7705A, TL7709A, TL7712A, TL7715A  
TL7702AY, TL7705AY, TL7709AY, TL7712AY, TL7715AY  
SUPPLY VOLTAGE SUPERVISORS**

SLVS028C – APRIL 1983 – REVISED AUGUST 1995

**absolute maximum ratings over operating free-air temperature (unless otherwise noted)†**

Supply voltage, $V_{CC}$ (see Note 1)	20 V
Input voltage range, $V_I$ , $\overline{RESIN}$	-0.3 V to 20 V
Input voltage range, $V_I$ , SENSE: TL7702A (see Note 2)	-0.3 V to 6 V
TL7705A	-0.3 V to 20 V
TL7709A	-0.3 V to 20 V
TL7712A, TL7715A	-0.3 V to 20 V
High-level output current, $I_{OH}$ , $\overline{RESET}$	-30 mA
Low-level output current, $I_{OL}$ , $\overline{RESET}$	30 mA
Continuous total power dissipation	See Dissipation Rating Table
Operating free-air temperature range, $T_A$ : TL77xxAC	0°C to 70°C
TL77xxAI	-40°C to 85°C
TL7702AM, TL7705AM	-55°C to 125°C
Storage temperature range, $T_{stg}$	-65°C to 150°C
Case temperature for 60 seconds, $T_C$ : FK package	260°C
Lead temperature 1,6 mm (1/16 inch) from case for 10 seconds: D or P package	260°C
Lead temperature 1,6 mm (1/16 inch) from case for 60 seconds: JG package	300°C

† Stresses beyond those listed under “absolute maximum ratings” may cause permanent damage to the device. These are stress ratings only, and functional operation of the device at these or any other conditions beyond those indicated under “recommended operating conditions” is not implied. Exposure to absolute-maximum-rated conditions for extended periods may affect device reliability.

NOTE 1: All voltage values are with respect to the network ground terminal.

**DISSIPATION RATING TABLE**

PACKAGE	$T_A \leq 25^\circ\text{C}$	DERATING FACTOR ABOVE $T_A = 25^\circ\text{C}$	$T_A = 70^\circ\text{C}$	$T_A = 85^\circ\text{C}$	$T_A = 125^\circ\text{C}$
	POWER RATING		POWER RATING	POWER RATING	POWER RATING
D	725 mW	5.8 mW/°C	464 mW	377 mW	145 mW
FK	1375 mW	11.0 mW/°C	880 mW	715 mW	275 mW
JG	1050 mW	8.4 mW/°C	672 mW	546 mW	210 mW
P	1000 mW	8.0 mW/°C	640 mW	520 mW	200 mW

**recommended operating conditions**

	TL77xxAC, TL77xxAI		TL77xxAM		UNIT	
	MIN	MAX	MIN	MAX		
Supply voltage, $V_{CC}$	3.5	18	3.6	10	V	
High-level input voltage at $\overline{RESIN}$ , $V_{IH}$	2		2		V	
Low-level input voltage at $\overline{RESIN}$ , $V_{IL}$		0.6		0.6	V	
Input voltage, SENSE, $V_I$	TL7702A	0	See Note 2	0	See Note 2	V
	TL7705A	0	10	0	10	
	TL7709A	0	15			
	TL7712A	0	20			
	TL7715A	0	20			
High-level output current, $\overline{RESET}$ , $I_{OH}$			-16		-16	mA
Low-level output current, $\overline{RESET}$ , $I_{OL}$			16		16	mA
Timing capacitor, $C_T$			10		10	μF
Operating free-air temperature range, $T_A$	TL77xxAC	0	70			°C
	TL77xxAI	-40	85			
	TL7702AM, TL7705AM			-55	125	

NOTE 2: For proper operation of the TL7702A, the voltage applied to the SENSE terminal should not exceed  $V_{CC} - 1$  V or 6 V, whichever is less.



**TL7702A, TL7705A, TL7709A, TL7712A, TL7715A**  
**TL7702AY, TL7705AY, TL7709AY, TL7712AY, TL7715AY**  
**SUPPLY VOLTAGE SUPERVISORS**  
 SLVS028C – APRIL 1983 – REVISED AUGUST 1995

**electrical characteristics over recommended operating conditions (unless otherwise noted)**

PARAMETER		TEST CONDITIONS†	TL77xxAC, TL77xxAI			UNIT	
			MIN	TYP	MAX		
$V_{OH}$	High-level output voltage, RESET	$I_{OH} = -16$ mA	$V_{CC} - 1.5$			V	
$V_{OL}$	Low-level output voltage, RESET	$I_{OL} = 16$ mA	0.4			V	
$V_{ref}$	Reference voltage	$T_A = 25^\circ\text{C}$	2.48	2.53	2.58	V	
$V_{IT-}$	Negative-going input threshold voltage, SENSE	$T_A = 25^\circ\text{C}$	TL7702A	2.48	2.53	2.58	V
			TL7705A	4.5	4.55	4.6	
			TL7709A	7.5	7.6	7.7	
			TL7712A	10.6	10.8	11	
			TL7715A	13.2	13.5	13.8	
$V_{hys}$	Hysteresis, SENSE ( $V_{IT+} - V_{IT-}$ )	$T_A = 25^\circ\text{C}$	TL7702A	10		mV	
			TL7705A	15			
			TL7709A	20			
			TL7712A	35			
			TL7715A	45			
$I_I$	Input current, RESIN	$V_I = 2.4$ V to $V_{CC}$	20			$\mu\text{A}$	
		$V_I = 0.4$ V	-100				
$I_I$	Input current, SENSE	TL7702A	$V_{ref} < V_I < V_{CC} - 1.5$ V		0.5	2	$\mu\text{A}$
$I_{OH}$	High-level output current, RESET	$V_O = 18$ V	50			$\mu\text{A}$	
$I_{OL}$	Low-level output current, RESET	$V_O = 0$	-50			$\mu\text{A}$	
$I_{CC}$	Supply current	All inputs and outputs open	1.8	3	mA		

† All electrical characteristics are measured with 0.1- $\mu\text{F}$  capacitors connected at REF, CT, and  $V_{CC}$  to GND.

**switching characteristics over recommended operating conditions (unless otherwise noted)**

PARAMETER		TEST CONDITIONS‡	TL77xxAC, TL77xxAI			UNIT
			MIN	TYP	MAX	
Output pulse duration		$C_T = 0.1$ $\mu\text{F}$	0.65	1.2	2.6	$\mu\text{s}$
Input pulse duration at RESIN			0.4			$\mu\text{s}$
$t_w(\text{S})$	Pulse duration at SENSE input to switch outputs	$V_{IH} = V_{IT-} + 200$ mV, $V_{IL} = V_{IT-} - 200$ mV	2			$\mu\text{s}$
$t_{pd}$	Propagation delay time from RESIN to RESET	$V_{CC} = 5$ V	1			$\mu\text{s}$
$t_r$	RESET	$V_{CC} = 5$ V, See Note 3	0.2			$\mu\text{s}$
	RESET		3.5			
$t_f$	RESET		3.5			$\mu\text{s}$
	RESET		0.2			

‡ All switching characteristics are measured with 0.1- $\mu\text{F}$  capacitors connected at REF and  $V_{CC}$  to GND.

NOTE 3: The rise and fall times are measured with a 4.7-k $\Omega$  load resistor at RESET and RESET.

TL7702A, TL7705A, TL7709A, TL7712A, TL7715A  
 TL7702AY, TL7705AY, TL7709AY, TL7712AY, TL7715AY  
 SUPPLY VOLTAGE SUPERVISORS

SLVS028C – APRIL 1983 – REVISED AUGUST 1995

**electrical characteristics over recommended operating conditions (unless otherwise noted)**

PARAMETER		TEST CONDITIONS†	TL7702AM, TL7705AM			UNIT
			MIN	TYP	MAX	
V <sub>OH</sub>	High-level output voltage, RESET	I <sub>OH</sub> = -16 mA	V <sub>CC</sub> - 1.5			V
V <sub>OL</sub>	Low-level output voltage, $\overline{\text{RESET}}$	I <sub>OL</sub> = 16 mA	0.4			V
V <sub>ref</sub>	Reference voltage		2.38	2.53	2.63	V
V <sub>IT-</sub>	Negative-going input threshold voltage, SENSE	TL7702AM	V <sub>CC</sub> = 3.6 V to 10 V			V
		TL7705AM	2.38	2.53	2.63	
V <sub>hys</sub>	Hysteresis SENSE (V <sub>IT+</sub> - V <sub>IT-</sub> )	TL7702AM	10			mV
		TL7705AM	15			
I <sub>I</sub>	Input current, $\overline{\text{RESIN}}$	V <sub>I</sub> = 2.4 V to V <sub>CC</sub>	20			μA
		V <sub>I</sub> = 0.4 V	-100			
I <sub>I</sub>	Input current, SENSE	TL7702AM	V <sub>ref</sub> < V <sub>I</sub> < V <sub>CC</sub> - 1.5 V			μA
I <sub>OH</sub>	High-level output current, $\overline{\text{RESET}}$	V <sub>O</sub> = 10 V	50			μA
I <sub>OL</sub>	Low-level output current, RESET	V <sub>O</sub> = 0	-50			μA
I <sub>CC</sub>	Supply current	All inputs and outputs open	1.8 3			mA

† All electrical characteristics are measured with 0.02-μF capacitors connected at REF, CT, and V<sub>CC</sub> to GND.

**switching characteristics over recommended operating conditions (unless otherwise noted)**

PARAMETER		TEST CONDITIONS‡	TL7702AM, TL7705AM			UNIT
			MIN	TYP	MAX	
t <sub>w(S)</sub>	Pulse duration at SENSE input to switch outputs	V <sub>IH</sub> = V <sub>IT-</sub> + 200 mV, V <sub>IL</sub> = V <sub>IT-</sub> - 200 mV	2*			μs
t <sub>pd</sub>	Propagation delay time, $\overline{\text{RESIN}}$ to $\overline{\text{RESET}}$	V <sub>CC</sub> = 5 V	1.5			μs
t <sub>r</sub>	RESET	V <sub>CC</sub> = 5 V, See Note 3	0.2*			μs
	$\overline{\text{RESET}}$		3.5*			
t <sub>f</sub>	RESET		3.5*			μs
	$\overline{\text{RESET}}$		0.2*			

\* On products compliant to MIL-STD-883, Class B, this parameter is not production tested.

‡ All switching characteristics are measured with 0.02-μF capacitors connected at REF and V<sub>CC</sub> to GND.

NOTE 3: The rise and fall times are measured with a 4.7-kΩ load resistor at  $\overline{\text{RESET}}$  and RESET.



TL7702A, TL7705A, TL7709A, TL7712A, TL7715A  
 TL7702AY, TL7705AY, TL7709AY, TL7712AY, TL7715AY  
**SUPPLY VOLTAGE SUPERVISORS**  
 SLVS028C – APRIL 1983 – REVISED AUGUST 1995

**electrical characteristics over recommended operating conditions,  $T_A = 25^\circ\text{C}$  (unless otherwise noted)**

PARAMETER		TEST CONDITIONS†	TL77xxAY			UNIT
			MIN	TYP	MAX	
$V_{\text{ref}}$	Reference voltage			2.53		V
$V_{\text{IT-}}$	Negative-going input threshold voltage, SENSE	TL7702A		2.53		V
		TL7705A		4.55		
		TL7709A		7.6		
		TL7712A		10.8		
		TL7715A		13.5		
$V_{\text{hys}}$	Hysteresis, SENSE ( $V_{\text{IT+}} - V_{\text{IT-}}$ )	TL7702A		10		mV
		TL7705A		15		
		TL7709A		20		
		TL7712A		35		
		TL7715A		45		
$I_{\text{I}}$	Input current, SENSE	TL7702A	$V_{\text{ref}} < V_{\text{I}} < V_{\text{CC}} - 1.5 \text{ V}$	0.5		$\mu\text{A}$
$I_{\text{CC}}$	Supply current		All inputs and outputs open	1.8		mA

† All electrical characteristics are measured with 0.1- $\mu\text{F}$  capacitors connected at REF, CT, and  $V_{\text{CC}}$  to GND.

**switching characteristics over recommended operating conditions,  $T_A = 25^\circ\text{C}$  (unless otherwise noted)**

PARAMETER		TEST CONDITIONS‡	TL77xxAY			UNIT
			MIN	TYP	MAX	
	Output pulse duration	$C_{\text{T}} = 0.1 \mu\text{F}$		1.2		$\mu\text{s}$

‡ All switching characteristics are measured with 0.1- $\mu\text{F}$  capacitors connected at REF and  $V_{\text{CC}}$  to GND.

PARAMETER MEASUREMENT INFORMATION

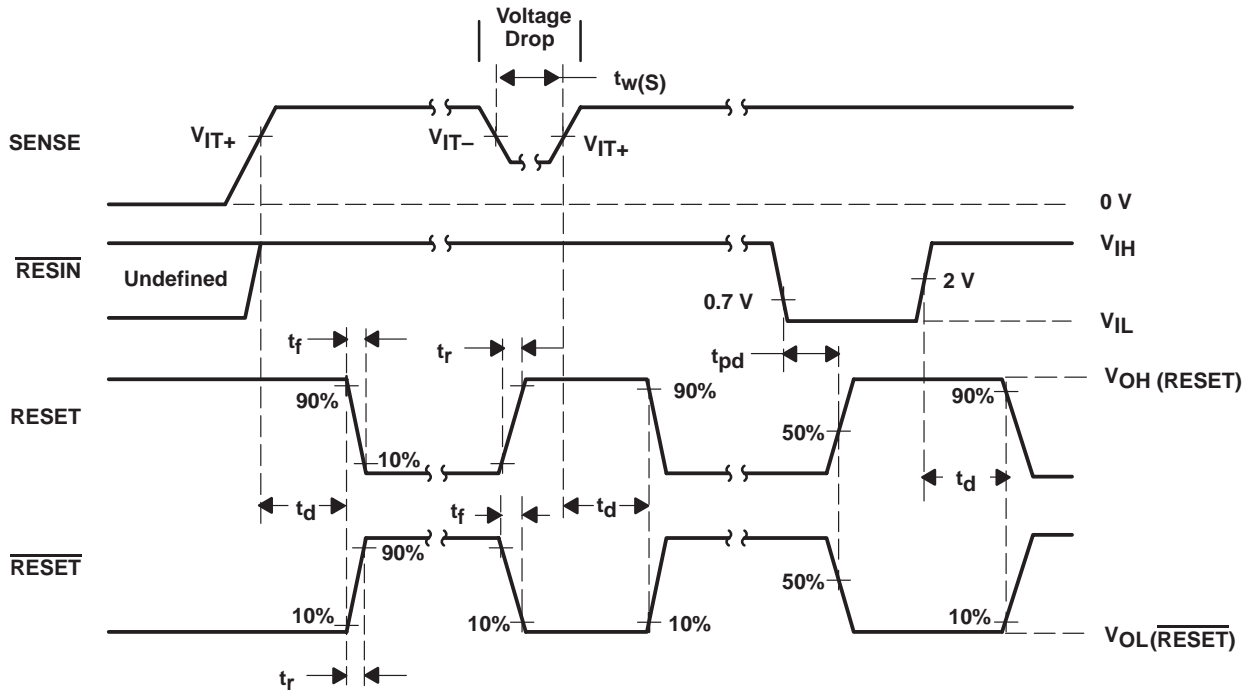
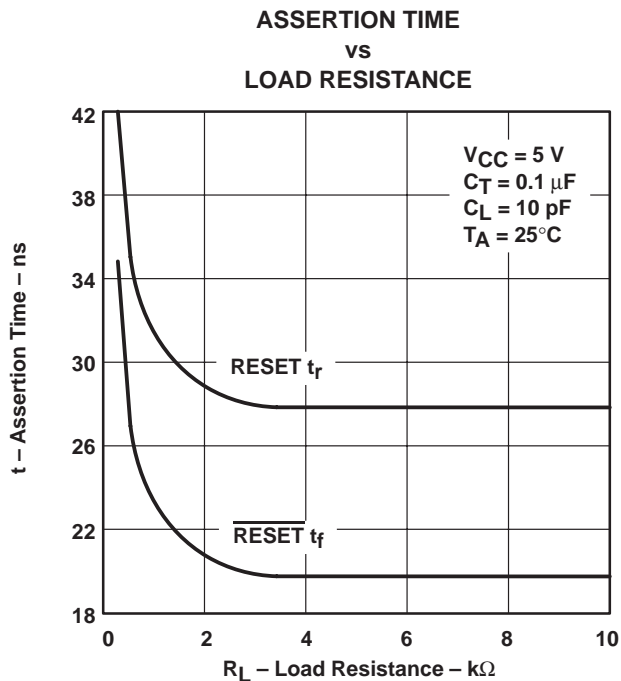

Figure 1. Voltage Waveforms



**TYPICAL CHARACTERISTICS†**



**Figure 2**

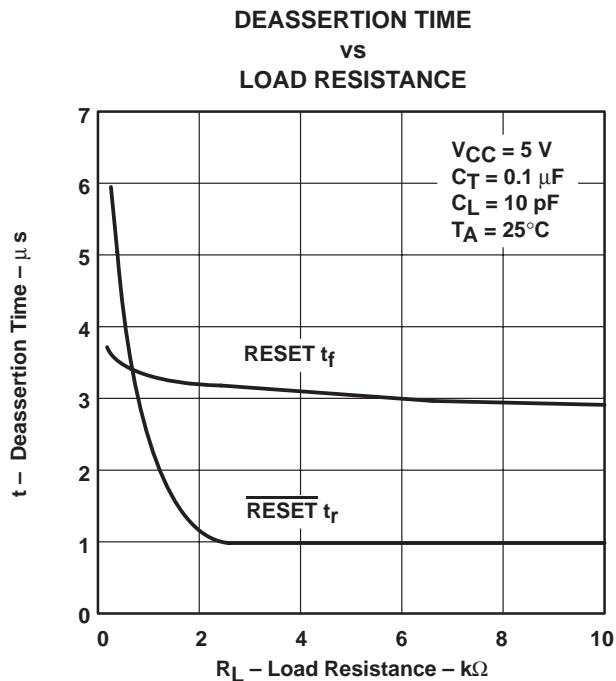

**Figure 3**

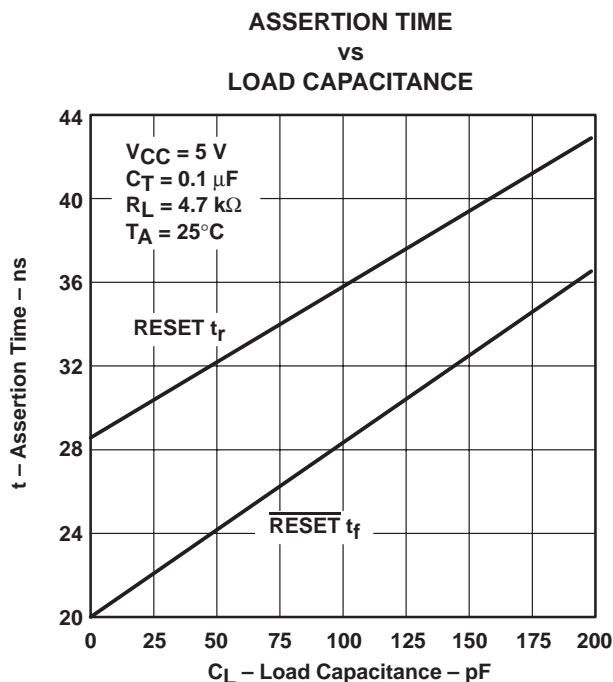

**Figure 4**

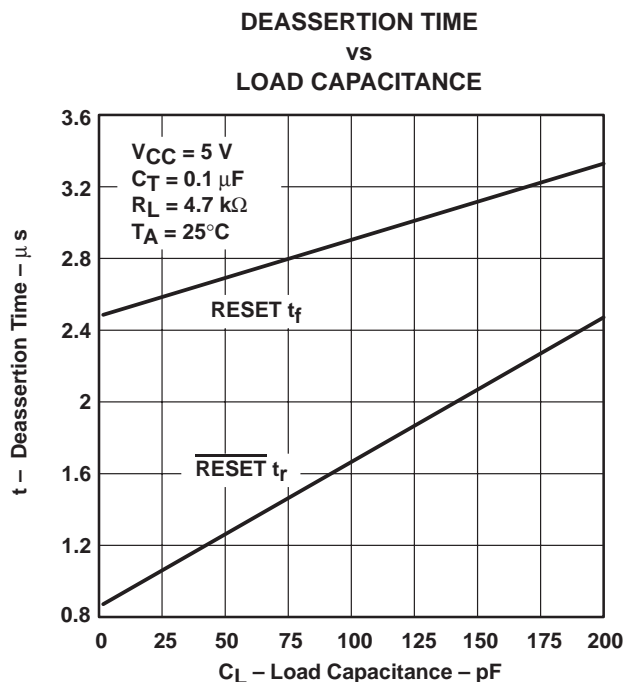

**Figure 5**

† For proper operation both RESET and  $\overline{\text{RESET}}$  should be terminated with resistors of similar value. Failure to do so may cause unwanted plateauing in either output waveform during switching.

APPLICATION INFORMATION

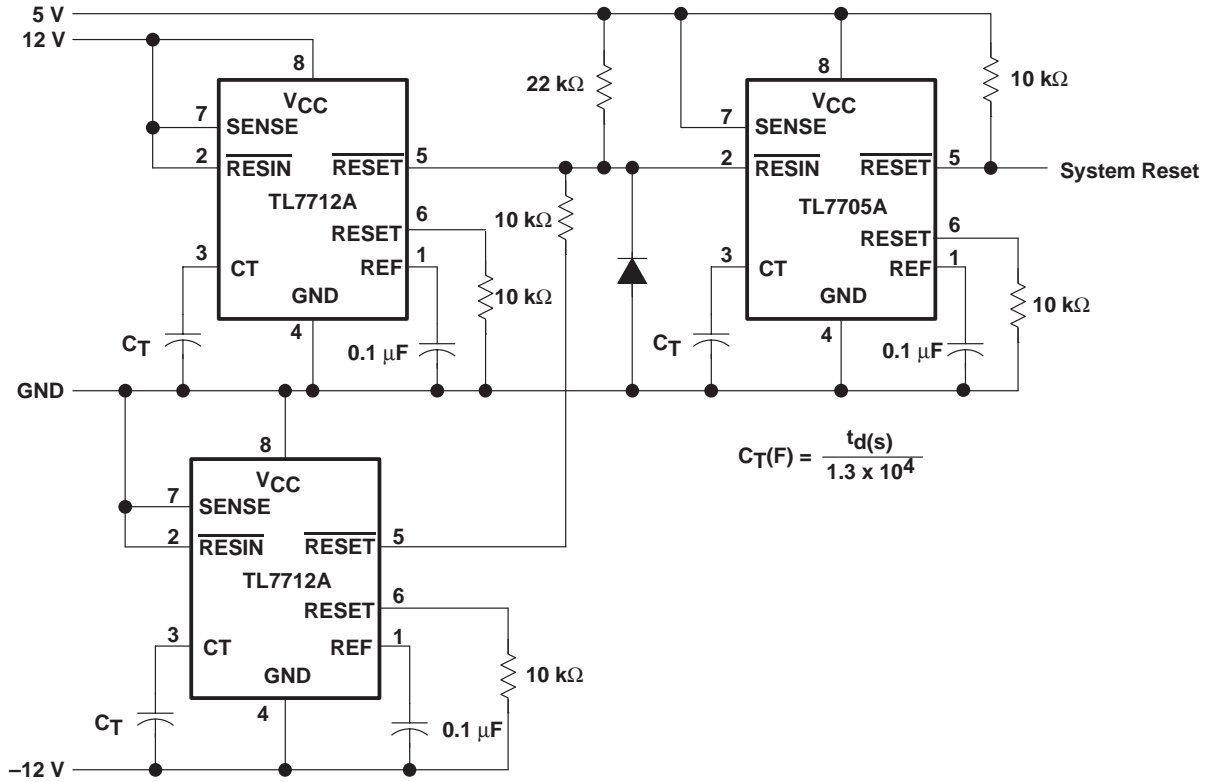

Figure 6. Multiple Power Supply System Reset Generation

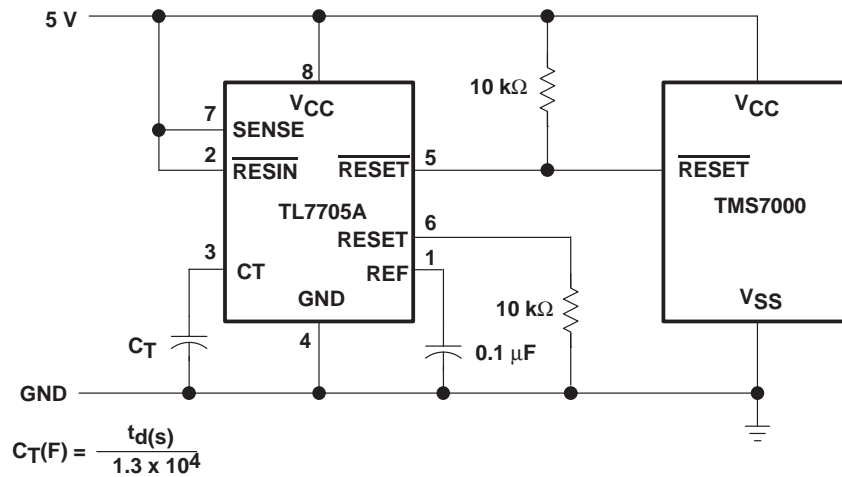

Figure 7. Reset Controller for TMS7000 System

Terminal numbers shown are for the D, JG, and P packages.

APPLICATION INFORMATION

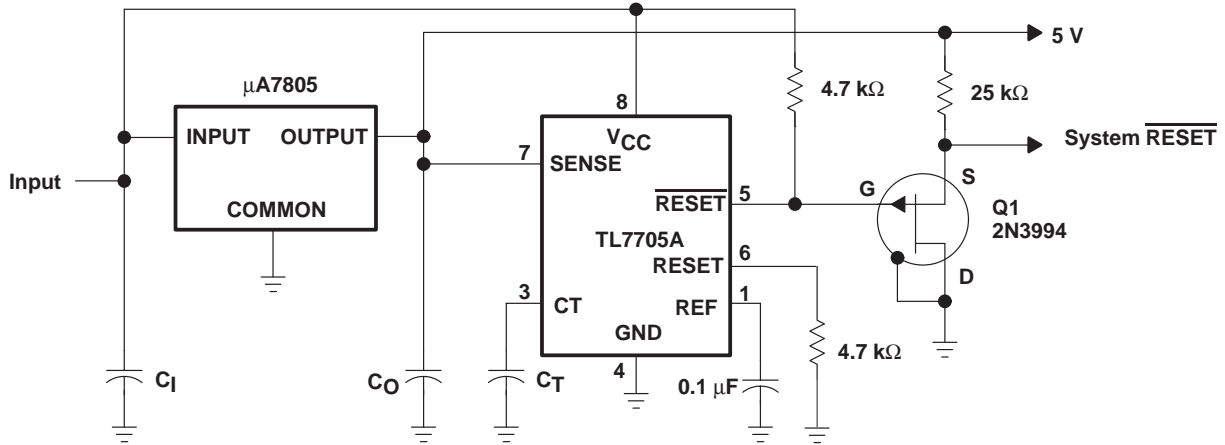

Figure 8. Eliminating Undefined States Using a P-Channel JFET

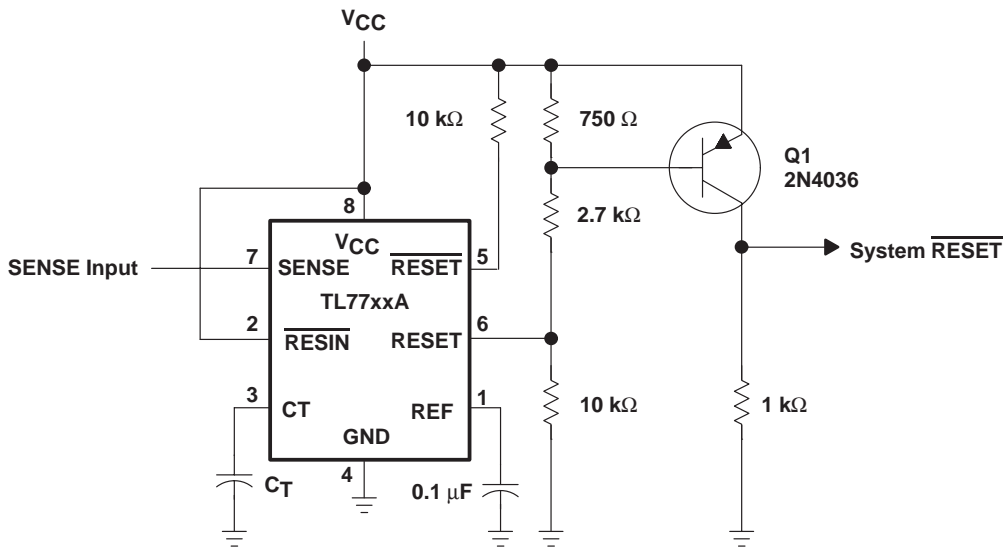

Figure 9. Eliminating Undefined States Using a pnp Transistor

Terminal numbers shown are for the D, JG, and P packages.



## IMPORTANT NOTICE

Texas Instruments and its subsidiaries (TI) reserve the right to make changes to their products or to discontinue any product or service without notice, and advise customers to obtain the latest version of relevant information to verify, before placing orders, that information being relied on is current and complete. All products are sold subject to the terms and conditions of sale supplied at the time of order acknowledgement, including those pertaining to warranty, patent infringement, and limitation of liability.

TI warrants performance of its semiconductor products to the specifications applicable at the time of sale in accordance with TI's standard warranty. Testing and other quality control techniques are utilized to the extent TI deems necessary to support this warranty. Specific testing of all parameters of each device is not necessarily performed, except those mandated by government requirements.

CERTAIN APPLICATIONS USING SEMICONDUCTOR PRODUCTS MAY INVOLVE POTENTIAL RISKS OF DEATH, PERSONAL INJURY, OR SEVERE PROPERTY OR ENVIRONMENTAL DAMAGE ("CRITICAL APPLICATIONS"). TI SEMICONDUCTOR PRODUCTS ARE NOT DESIGNED, AUTHORIZED, OR WARRANTED TO BE SUITABLE FOR USE IN LIFE-SUPPORT DEVICES OR SYSTEMS OR OTHER CRITICAL APPLICATIONS. INCLUSION OF TI PRODUCTS IN SUCH APPLICATIONS IS UNDERSTOOD TO BE FULLY AT THE CUSTOMER'S RISK.

In order to minimize risks associated with the customer's applications, adequate design and operating safeguards must be provided by the customer to minimize inherent or procedural hazards.

TI assumes no liability for applications assistance or customer product design. TI does not warrant or represent that any license, either express or implied, is granted under any patent right, copyright, mask work right, or other intellectual property right of TI covering or relating to any combination, machine, or process in which such semiconductor products or services might be or are used. TI's publication of information regarding any third party's products or services does not constitute TI's approval, warranty or endorsement thereof.