

TPS6735 FIXED NEGATIVE 5-V 200-mA INVERTING DC/DC CONVERTER

SLVS141A – JULY 1996 – REVISED JANUARY 1997

- Negative 5-V 200-mA Output ($V_{CC} \geq 4.5\text{ V}$)
- 4-V to 6.2-V Input Operating Range
- 78% Typical Efficiency
- 160-kHz Fixed-Frequency Current-Mode PWM Controller
- EN Input Inhibits Operation and Reduces Supply Current to $1\ \mu\text{A}$
- Soft Start
- 8-Pin SOIC and DIP Packages
- -40°C to 85°C Free-Air Temperature Range
- Pin-for-Pin Compatible with MAX735

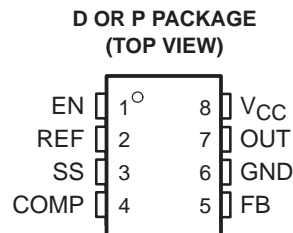

description

The TPS6735 is a fixed negative 5-V output inverting dc/dc converter capable of delivering 200 mA from inputs as low as 4.5 V. The only external components required are an inductor, an output filter capacitor, an input filter capacitor, a reference filter capacitor, and a Schottky rectifier. An enable input is provided to shut down the inverter when a -5-V output is not needed. The typical supply current is 1.9 mA at no-load and is further reduced to $1\text{-}\mu\text{A}$ when the enable input is low.

The TPS6735 is a 160-kHz current-mode pulse-width-modulation (PWM) controller with a p-channel MOSFET power switch. The gate drive uses the -5-V output to reduce the die area needed to realize the $0.4\text{-}\Omega$ MOSFET. Soft start is accomplished with the addition of one small capacitor at SS. A 1.22-V reference is available for external loads up to 125 μA .

The TPS6735 is attractive for board-level dc/dc conversion in computer peripherals and in battery-powered equipment requiring high efficiency and low supply current.

The TPS6735 is available in 8-pin DIP and SOIC packages and operates over a free-air temperature range of -40°C to 85°C .

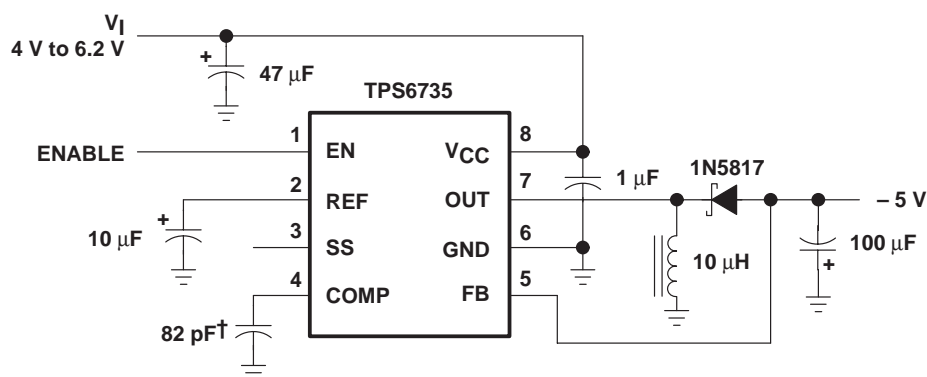

† Not required for loads of 100 mA or less

Figure 1. Typical Circuit



Please be aware that an important notice concerning availability, standard warranty, and use in critical applications of Texas Instruments semiconductor products and disclaimers thereto appears at the end of this data sheet.

PRODUCTION DATA information is current as of publication date. Products conform to specifications per the terms of Texas Instruments standard warranty. Production processing does not necessarily include testing of all parameters.

**TEXAS
INSTRUMENTS**

POST OFFICE BOX 655303 • DALLAS, TEXAS 75265

Copyright © 1997, Texas Instruments Incorporated

TPS6735 FIXED NEGATIVE 5-V 200-mA INVERTING DC/DC CONVERTER

SLVS141A – JULY 1996 – REVISED JANUARY 1997

AVAILABLE OPTIONS

T _A	PACKAGED DEVICES		CHIP FORM (Y)
	SMALL OUTLINE (D)	PLASTIC DIP (P)	
-40°C to 85°C	TPS6735ID	TPS6735IP	TPS6735Y

The D package is also available taped and reeled (TPS6735IDR).

functional block diagram

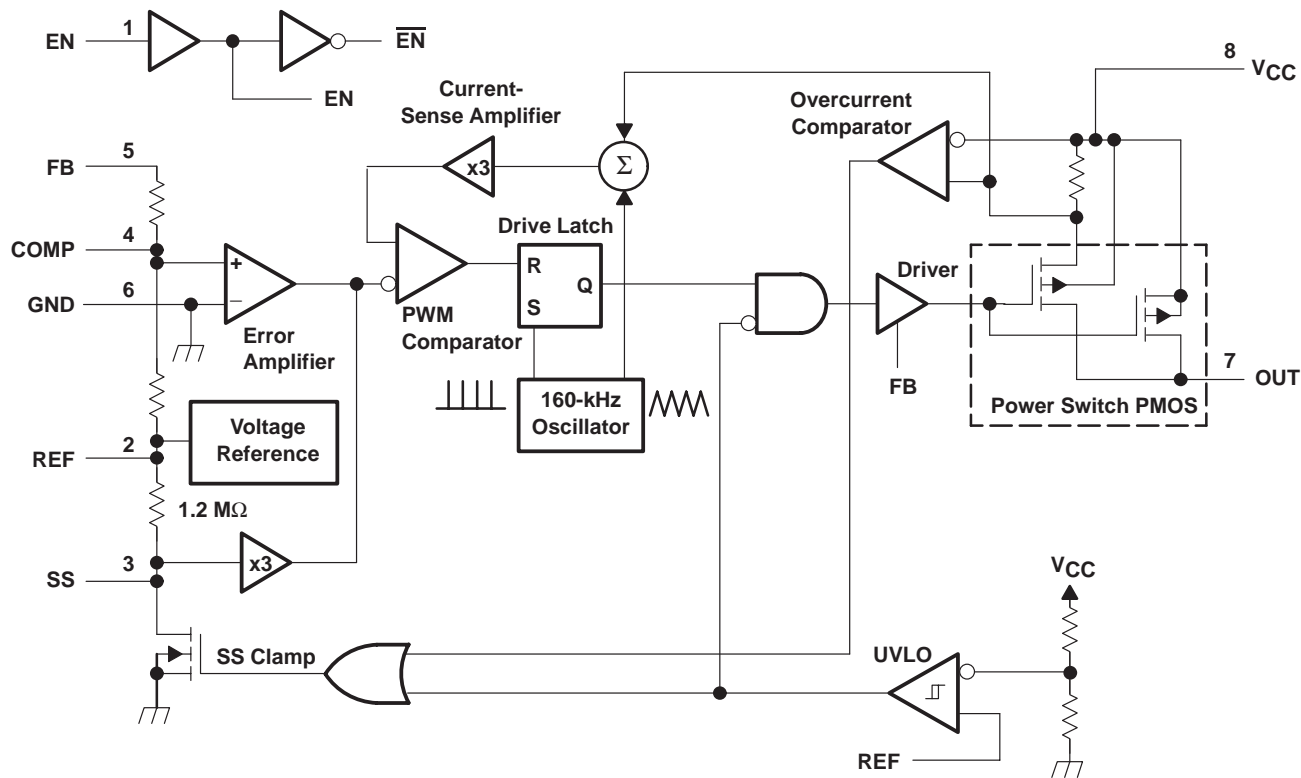

TPS6735

FIXED NEGATIVE 5-V 200-mA INVERTING DC/DC CONVERTER

SLVS141A – JULY 1996 – REVISED JANUARY 1997

chip information

These chips, when properly assembled, display characteristics similar to the TPS6735. Thermal compression or ultrasonic bonding may be used on the doped aluminum bonding pads. The chips may be mounted with conductive epoxy or a gold-silicon preform.

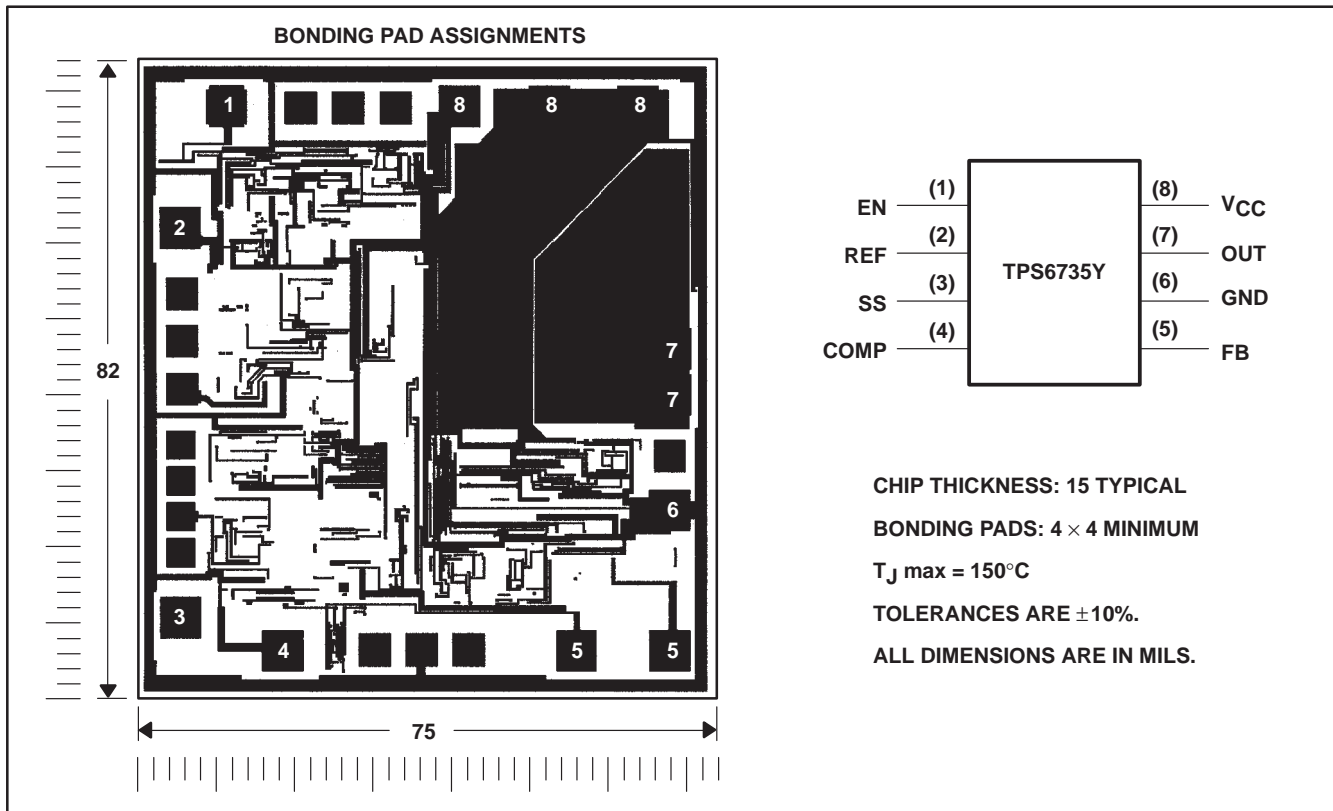

Terminal Functions

TERMINAL NAME	NO.	DESCRIPTION
EN	1	Enable. EN > 2 V turns on the TPS6735. EN ≤ 0.4 V turns it off.
REF	2	1.22-V reference voltage output. REF can source 125 μA for external loads.
SS	3	Soft start. A capacitor between SS and GND brings the output voltage up slowly.
COMP	4	Compensation. A capacitor to ground stabilizes the feedback loop.
FB	5	Feedback. FB connects to the dc/dc converter output.
GND	6	Ground
OUT	7	Power MOSFET drain connection
VCC	8	Supply-voltage input

TPS6735

FIXED NEGATIVE 5-V 200-mA INVERTING DC/DC CONVERTER

SLVS141A – JULY 1996 – REVISED JANUARY 1997

detailed description

The following descriptions refer to the functional block diagram.

current-sense amplifier

The current-sense amplifier, which has a fixed gain of 3, amplifies the slope-compensated current-sense voltage (a summation of the voltage on the current-sense resistor and the oscillator ramp) and feeds it to the PWM comparator.

driver latch

The latch, which consists of a set/reset flip-flop and associated logic, controls the state of the power switch by turning the driver on and off. A high output from the latch turns the switch on; a low output turns it off. In normal operation the flip-flop is set high during the clock pulse, but gating keeps the latch output low until the clock pulse is over. The latch is reset when the PWM comparator output goes high.

enable (EN)

A logic low on EN puts the TPS6735 in shutdown mode. In shutdown, the output power switch, voltage reference, and other functions shut off and the supply current is reduced to 1- μ A maximum. The soft-start capacitor is discharged through a 1.2-M Ω resistance and the output falls to zero volts.

error amplifier

The error amplifier is a high-gain differential amplifier used to regulate the converter output voltage. The amplifier generates an error signal, which is fed to the PWM comparator, by comparing a sample of the output voltage to the reference and amplifying the difference. The output sample is obtained from a resistive divider connected between FB and REF. FB is connected externally to the converter output, and the divider output is connected to the error-amplifier input. An 82-pF capacitor connected between COMP and GND is required to stabilize the control loop for loads greater than 100 mA.

oscillator and ramp generator

The oscillator circuit provides a 160-kHz clock to set the converter operating frequency, and a timing ramp for slope compensation. The clock waveform is a pulse, a few hundred nanoseconds in duration, that is used to limit the maximum power switch duty cycle to 95%. The timing ramp is summed with the current-sense signal at the input to the current-sense amplifier.

overcurrent comparator

The overcurrent comparator monitors the current in the power switch. The comparator trips and initiates a soft-start cycle if the power-switch current exceeds 2 A peak.

power switch

The power switch is a 0.4- Ω p-channel MOSFET with current sensing. The drain is connected to OUT and the current sense is connected to a resistor. The voltage across the resistor is proportional to current in the power switch and is tied to the overcurrent comparator and the current-sense amplifier. In normal operation, the power switch is turned on at the start of each clock cycle and turned off when the PWM comparator resets the drive latch.

PWM comparator

The comparator resets the drive latch and turns off the power switch whenever the slope-compensated current-sense signal from the current-sense amplifier exceeds the error signal.

reference

The 1.22-V reference is brought out on REF and can source 125- μ A maximum to external loads. A 10- μ F capacitor connected between REF and GND is recommended to minimize noise pickup.



POST OFFICE BOX 655303 • DALLAS, TEXAS 75265

TPS6735

FIXED NEGATIVE 5-V 200-mA INVERTING DC/DC CONVERTER

SLVS141A – JULY 1996 – REVISED JANUARY 1997

SS clamp

The SS clamp circuit limits the signal level on error-amplifier output during start-up. The voltage on SS is amplified and used to override the error-amplifier output until it rises above that output, at which point the error amplifier takes over. This prevents the input to the PWM comparator from exceeding its common-mode range (i.e., error amplifier output too high to be reached by the current ramp) by limiting the maximum voltage on the error-amplifier output during start-up.

Soft start causes the output voltage to increase to the regulation point at the controlled rate. The voltage on the charging soft-start capacitor gradually raises the clamp on the error amplifier output voltage, limiting surge currents at power up by increasing the current limit threshold on a cycle-by-cycle basis. A soft-start cycle is initiated when either the enable (EN) signal is switched high or an overcurrent fault condition triggers the discharge of the soft-start capacitor.

undervoltage lockout (UVLO)

The supply voltage is fed through a voltage divider to the input of the UVLO and compared to a reference. The undervoltage-lockout logic prevents the MOSFET from turning on while the supply voltage is below the undervoltage-lockout voltage threshold, and once the supply voltage on V_{CC} is above the threshold, an SS cycle is initiated.

DISSIPATION RATING TABLE

PACKAGE	$T_A \leq 25^\circ\text{C}$ POWER RATING	DERATING FACTOR ABOVE $T_A = 25^\circ\text{C}$	$T_A = 70^\circ\text{C}$ POWER RATING	$T_A = 85^\circ\text{C}$ POWER RATING
D	725 mW	5.8 mW/ $^\circ\text{C}$	464 mW	377 mW
P	1175 mW	9.4 mW/ $^\circ\text{C}$	752 mW	611 mW

absolute maximum ratings over operating free-air temperature range (unless otherwise noted)†

Pin voltages:	V_{CC} (see Note 1)	–0.3 V to 7 V
	OUT to V_{CC}	12.5 V
	FB (see Note 1)	25 V
	SS, COMP, EN voltage range (see Note 1)	–0.3 V to $V_{CC} + 0.3$ V
Peak switch current		2 A
Reference current		2.5 mA
Continuous total power dissipation	See Dissipation Rating Table	
Operating free-air temperature range, T_A		–40 $^\circ\text{C}$ to 85 $^\circ\text{C}$
Storage temperature range, T_{stg}		–65 $^\circ\text{C}$ to 150 $^\circ\text{C}$
Lead temperature 1,6mm (1/16 inch) from case for 10 s		260 $^\circ\text{C}$

† Stresses beyond those listed under “absolute maximum ratings” may cause permanent damage to the device. These are stress ratings only, and functional operation of the device at these or any other conditions beyond those indicated under “recommended operating conditions” is not implied. Exposure to absolute-maximum-rated conditions for extended periods may affect device reliability.

NOTE 1: All voltage values are with respect to network terminal ground.

recommended operating conditions

	MIN	NOM	MAX	UNIT
Supply voltage	4		6.2	V
Decoupling capacitor		1		μF
Input capacitor		47		μF
Reference capacitor		10		μF
Output capacitor		100		μF
Compensation capacitor		82		pF
Inductor		10		μH



TPS6735

FIXED NEGATIVE 5-V 200-mA INVERTING DC/DC CONVERTER

SLVS141A – JULY 1996 – REVISED JANUARY 1997

electrical characteristics over recommended operating free-air temperature range, $V_{CC} = 5\text{ V}$, $I_O = 0$, $EN = 5\text{ V}$, typical values are at $T_A = 25^\circ\text{C}$ (unless otherwise noted) (refer to Figure 15)

PARAMETER	TEST CONDITION	MIN	TYP	MAX	UNIT
Supply current			1.9		mA
Standby current	$EN = 0.4\text{ V}$		1	10	μA
High-level input threshold voltage, EN				2	V
Low-level input threshold voltage, EN		0.4			V
Input current, EN		-1		1	μA
Compensation pin impedance			7.5		$\text{k}\Omega$
Oscillator frequency			160		kHz
Reference voltage	$I_{O(\text{ref})} \leq 125\ \mu\text{A}$		1.22		V
Reference drift			50		ppm/ $^\circ\text{C}$
Undervoltage lockout			3.7		V
On resistance, OUT			0.4		Ω
Leakage current, OUT			20		nA

performance characteristics over recommended operating free-air temperature range, typical values at $T_A = 25^\circ\text{C}$ (unless otherwise noted) (refer to Figure 15)

PARAMETER	TEST CONDITION	MIN	TYP	MAX	UNIT
Output voltage	$V_{CC} = 4.5\text{ V to }6.2\text{ V}$ $I_O = 0\text{ mA to }200\text{ mA}$	-4.75	-5	-5.25	V
Load current	$V_{CC} = 4.5\text{ V to }6.2\text{ V}$	200	270		mA
Line regulation	$V_{CC} = 4.5\text{ V to }6.2\text{ V}$		0.2%		
Load regulation	$I_O = 25\text{ mA to }200\text{ mA}$		0.2%		
Efficiency	$I_O = 100\text{ mA}$		78%		



APPLICATION INFORMATION

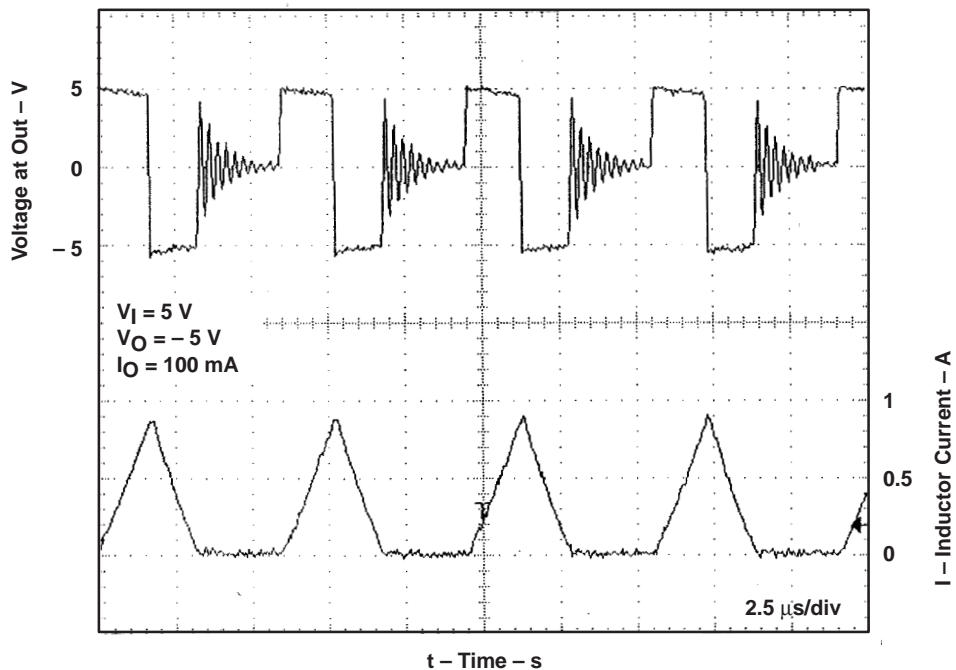

Figure 2. Switching Waveforms

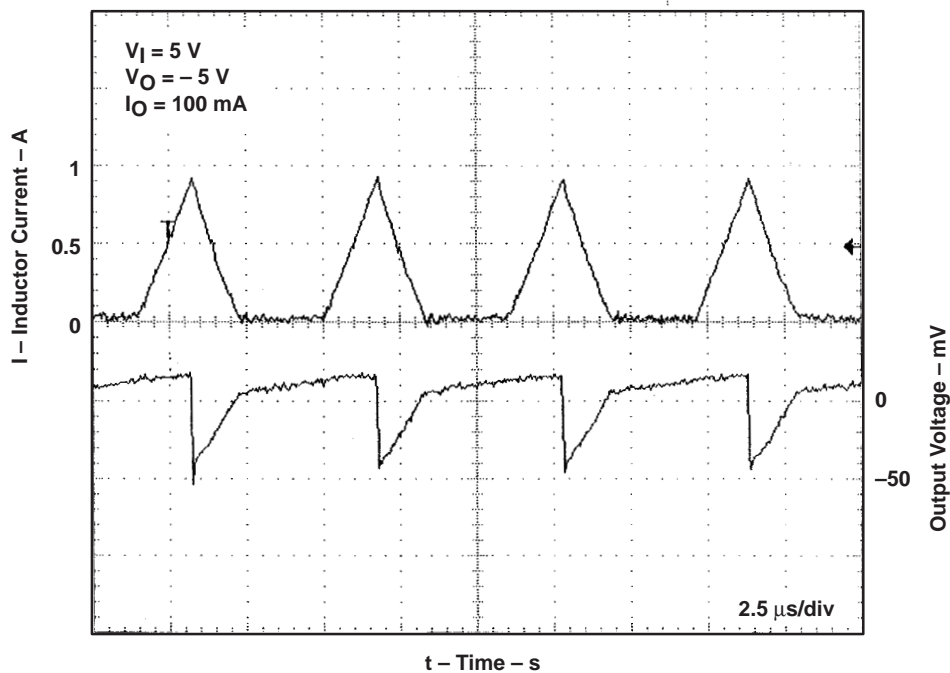

Figure 3. Output Voltage Ripple

TPS6735 FIXED NEGATIVE 5-V 200-mA INVERTING DC/DC CONVERTER

SLVS141A – JULY 1996 – REVISED JANUARY 1997

APPLICATION INFORMATION

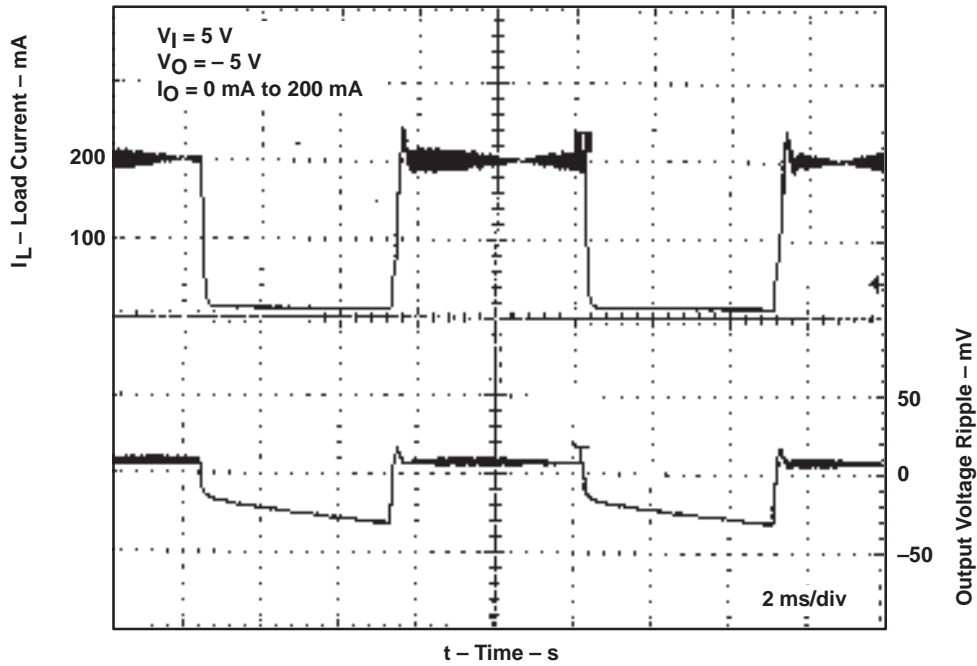

Figure 4. Load Transient Response

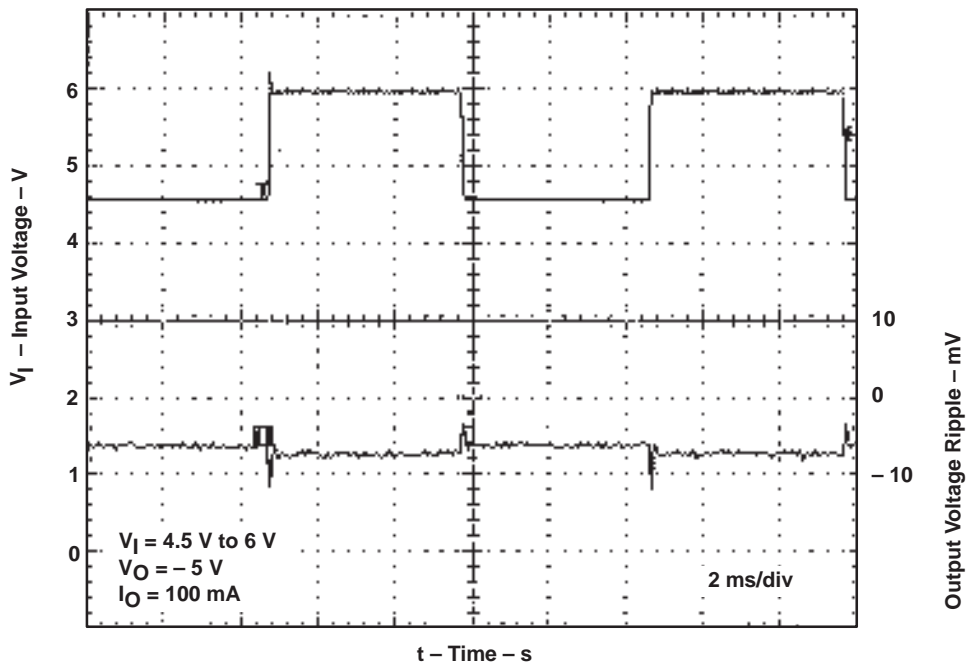

Figure 5. Line Transient Response

APPLICATION INFORMATION

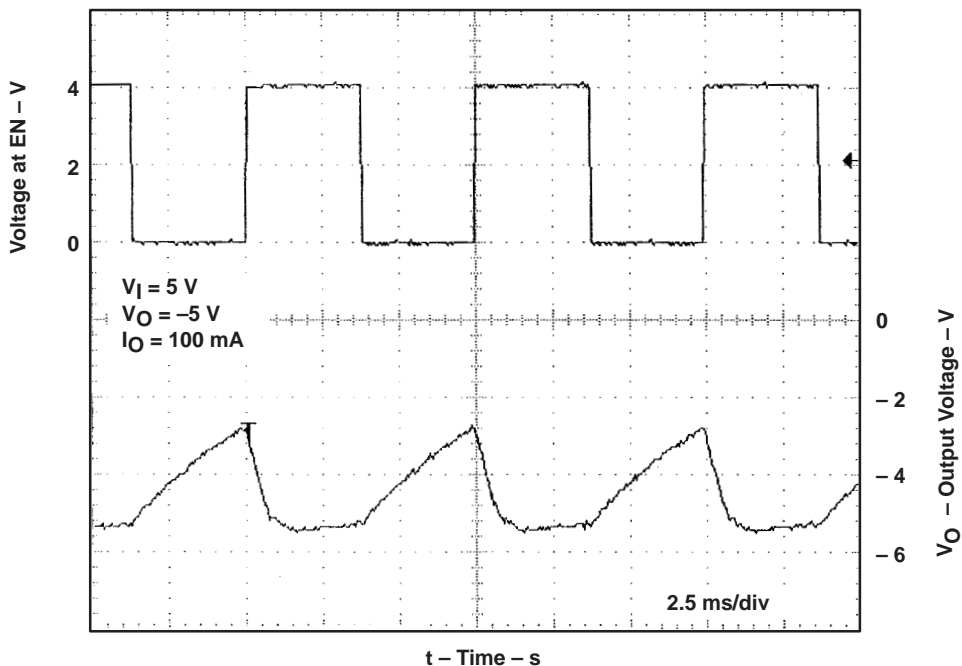

Figure 6. Enable Response Time

system typical characteristics

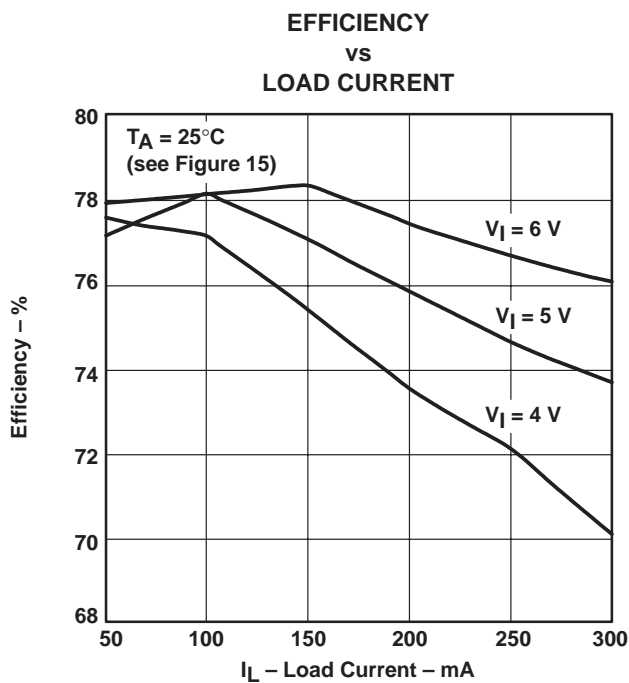

Figure 7

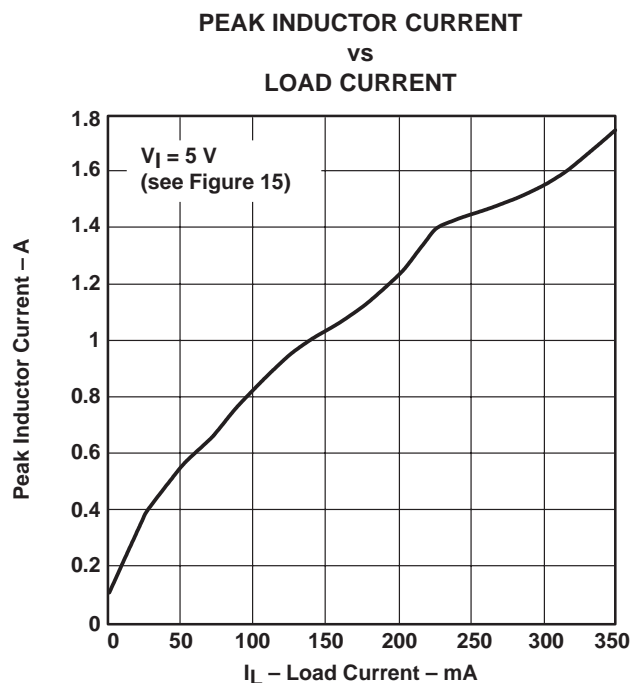

Figure 8

TPS6735 FIXED NEGATIVE 5-V 200-mA INVERTING DC/DC CONVERTER

SLVS141A – JULY 1996 – REVISED JANUARY 1997

APPLICATION INFORMATION

system typical characteristics (continued)

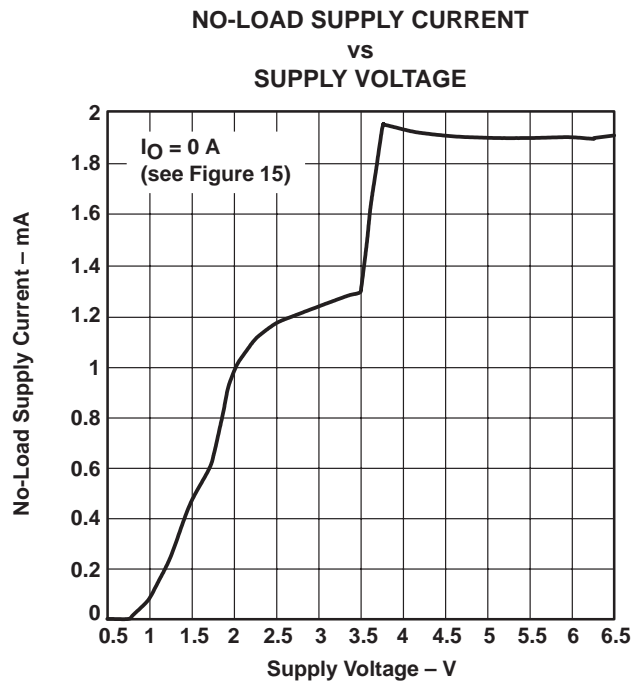

Figure 9

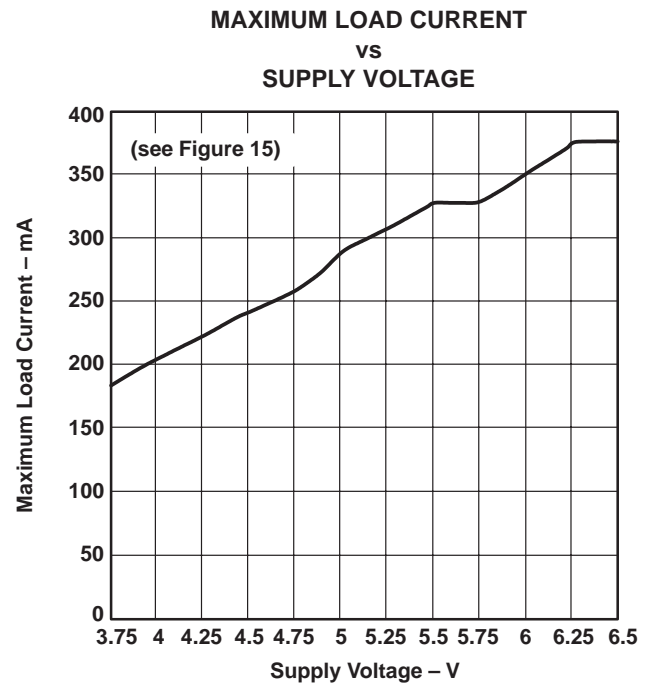

Figure 10

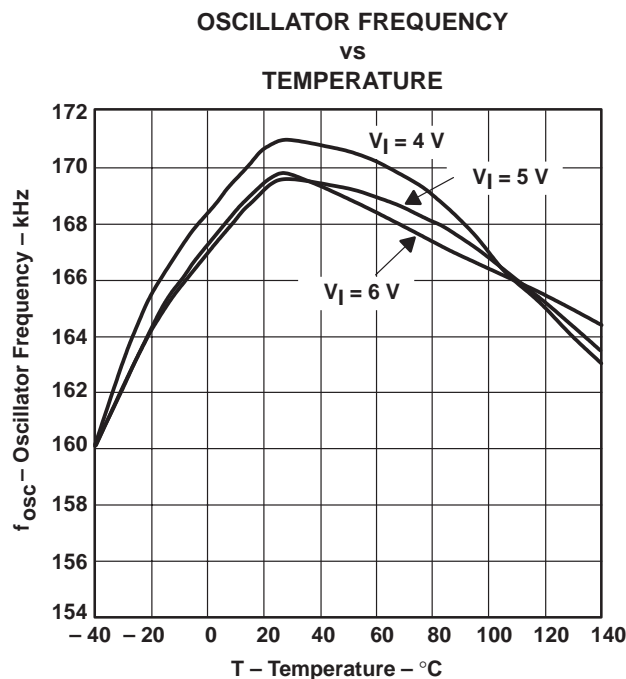

Figure 11

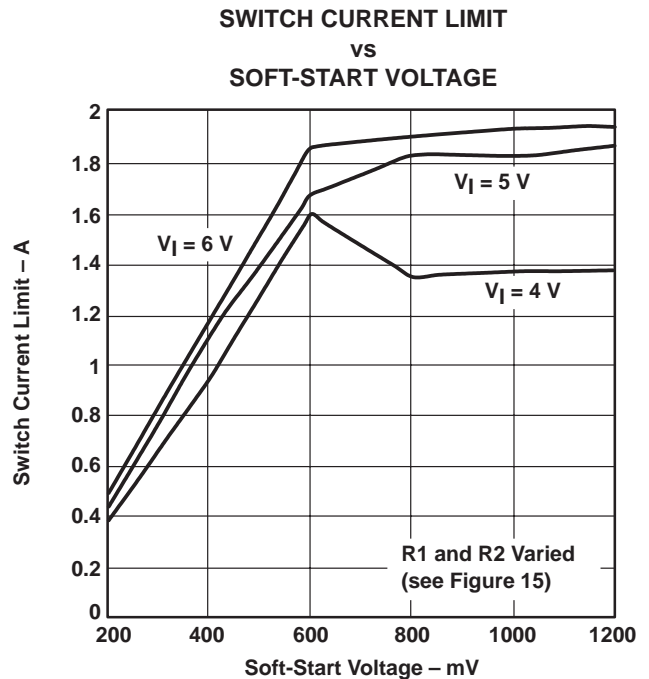

Figure 12

APPLICATION INFORMATION

system typical characteristics (continued)

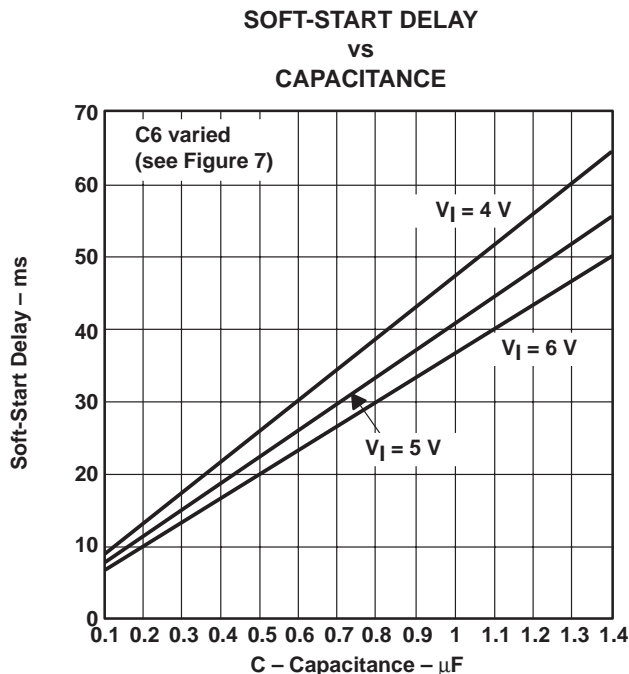

Figure 13

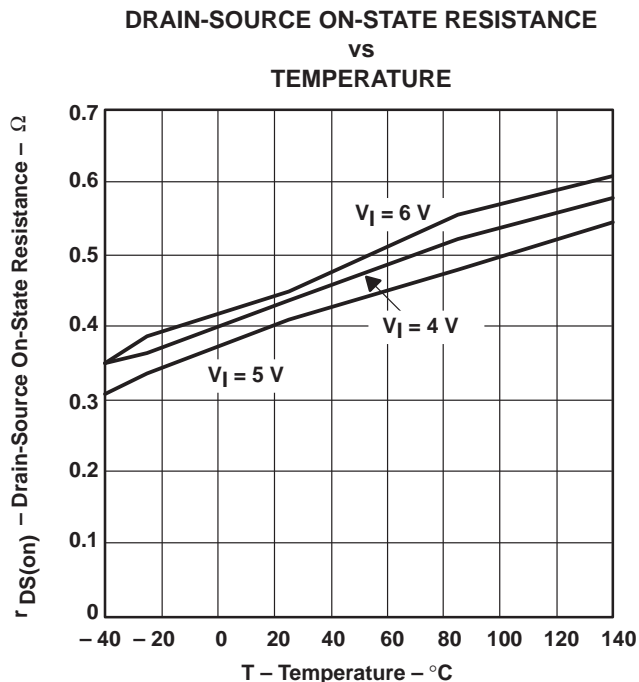

Figure 14

The TPS6735 operates in the voltage-inverting circuit, shown in Figure 15, which can generate a -5-V output. The circuit is ideal for applications that require a negative polarity voltage on the output with respect to the input ground, and for energy management systems. The TPS6735 can be placed in a shutdown mode (1-μA quiescent current) by forcing EN low.

soft start

The soft-start capacitor provides an orderly start-up of the converter by slowly increasing the switch current limit during power-up. The soft-start timing is controlled by the SS capacitance (see Figure 13 for the capacitance value corresponding to the desired delay time). The switch current limit is proportional to the voltage applied to SS, which is internally pulled to REF by a 1.2-MΩ resistor. SS can be externally pulled lower than REF to limit the switch current. A UVLO condition or an overcurrent condition initiates an SS cycle by discharging the SS capacitor to ground through an internal transistor. A minimum of a 10-nF capacitor must be connected to SS to current limit correctly.

inductor selection

The standard 10-μH inductor required by the TPS6735 must have a saturation current greater than the peak switch current at the desired maximum load. Operation over the full voltage range and current range is assured by the 10-μH inductor. To determine the required inductor saturation level, refer to the typical operating characteristics graph for peak inductor current versus load current (see Figure 8).

TPS6735 FIXED NEGATIVE 5-V 200-mA INVERTING DC/DC CONVERTER

SLVS141A – JULY 1996 – REVISED JANUARY 1997

APPLICATION INFORMATION

output filter capacitor

A low equivalent series resistance (ESR) output filter capacitor is necessary to minimize the output-ripple voltage. An ESR of 100 mΩ limits the output ripple to 90 mV or less for output loads up to 200 mA.

rectifier

A Schottky diode or high-speed silicon rectifier should be used with a maximum continuous current rating of 1 A for operation up to full load (200 mA).

output ripple filtering

A low-pass filter may be added to the converter output to reduce the output voltage ripple (see Figure 15). The LC filter has a cutoff frequency of 7.2 kHz. The inductor filter must have a low resistance to avoid large output voltage drops. The output voltage ripple is reduced to 5 mV when the LC output filter is used. FB must be connected to the output node before the connection for the low-pass filter.

printed circuit board layout

A ground plane is recommended in a printed circuit board (PCB) layout to ensure quiet operation. Attention should be given to minimizing the lengths of the switching loops. Bypass capacitors should be placed as close to the TPS6735 as possible to prevent instability and noise pickup. V_{CC} and GND should be bypassed directly with a 1-μF ceramic capacitor and a large bypass capacitor (e.g. 47 μF) to maximize noise immunity. The TPS6735 should not be used with IC sockets, wire-wrap prototype boards, or other constructions that are susceptible to noise pick-up.

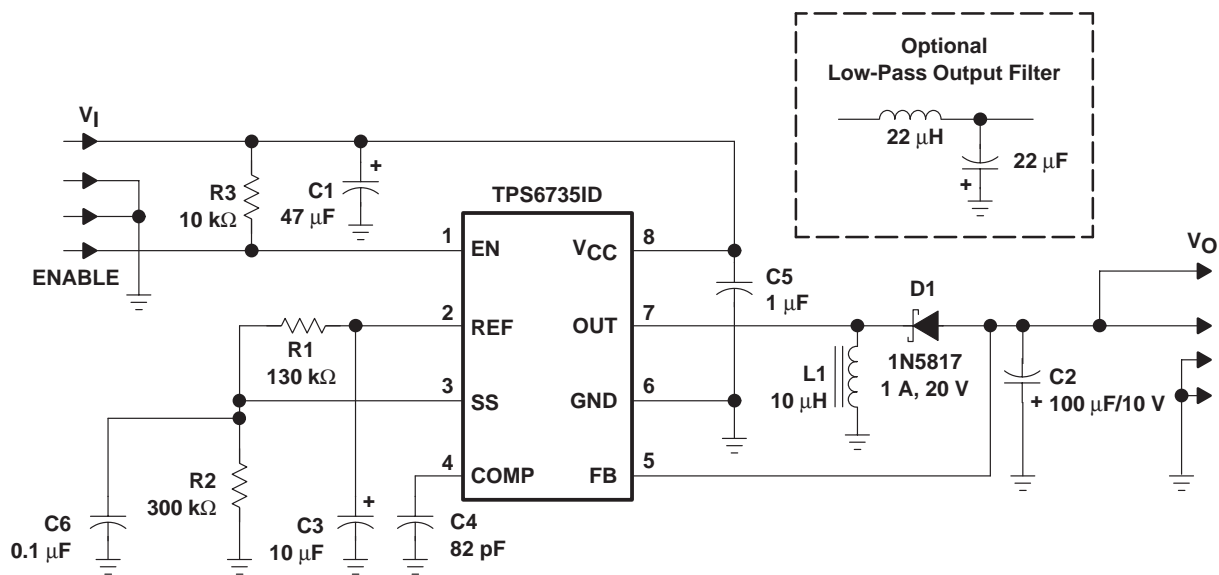

Figure 15. Application Circuit

TPS6735 FIXED NEGATIVE 5-V 200-mA INVERTING DC/DC CONVERTER

SLVS141A – JULY 1996 – REVISED JANUARY 1997

APPLICATION INFORMATION

Table 1. Bill of Materials

QTY	DESCRIPTION				REF DES	MANUFACTURER PART NO.	MANUFACTURER
1	IC	Power supply	-5 V		U1	TPS6735ID	Texas Instruments
1	Diode	Schottky			D1	1N5817GI	General Instrument
1	Inductor	10 μ H			L1	DO1608C-103 CD54-100	Coilcraft, Sumida
1	Capacitor	47 μ F tantalum	16 V	7343	C1	593D476X9016D2W TPSD476K016R0100	Sprague, AVX
1	Capacitor	100 μ F tantalum	10 V	7343	C2	593D107X9010D2W TPSD107D016R0100	Sprague, AVX
1	Capacitor	10 μ F tantalum	10 V	3528	C3	293D106X0010B2W 267E 1002 106	Sprague, MATSUO
1	Capacitor	82 pF ceramic	50 V	0805	C4		
1	Capacitor	1 μ F ceramic	16 V	1206	C5		
1	Capacitor	0.1 μ F ceramic	50 V	0805	C6		
1	Resistor	130 k Ω		0805	R1		
1	Resistor	300 k Ω		0805	R2		
1	Resistor	10 k Ω		0805	R3		

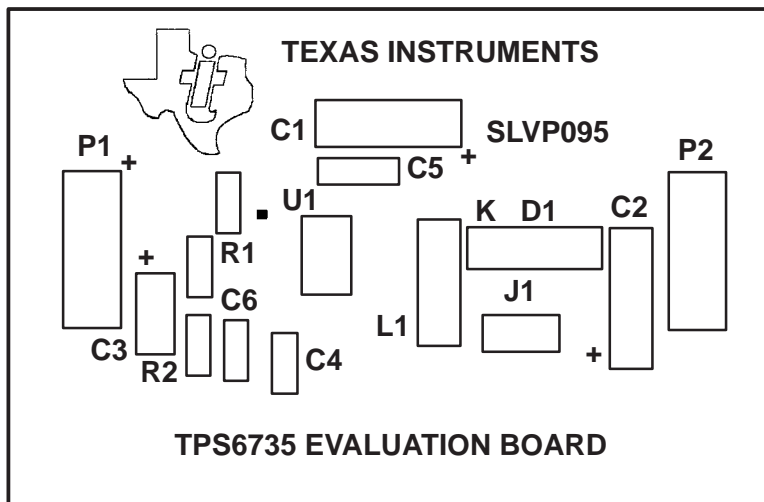

SILK SCREEN TOP

Figure 16. Component Placement

TPS6735
FIXED NEGATIVE 5-V 200-mA INVERTING DC/DC CONVERTER

SLVS141A – JULY 1996 – REVISED JANUARY 1997

APPLICATION INFORMATION

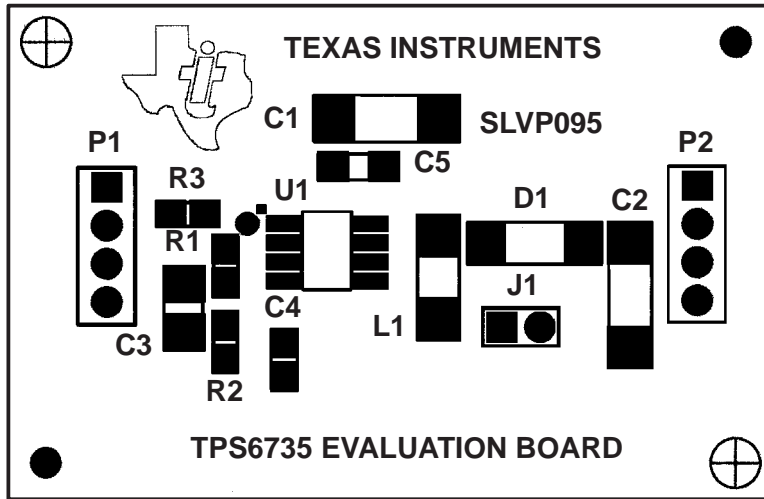

SOLDER PASTE MASK

Figure 17. Solder Paste Mask



COMPONENT SIDE

Figure 18. PC Component Side

APPLICATION INFORMATION

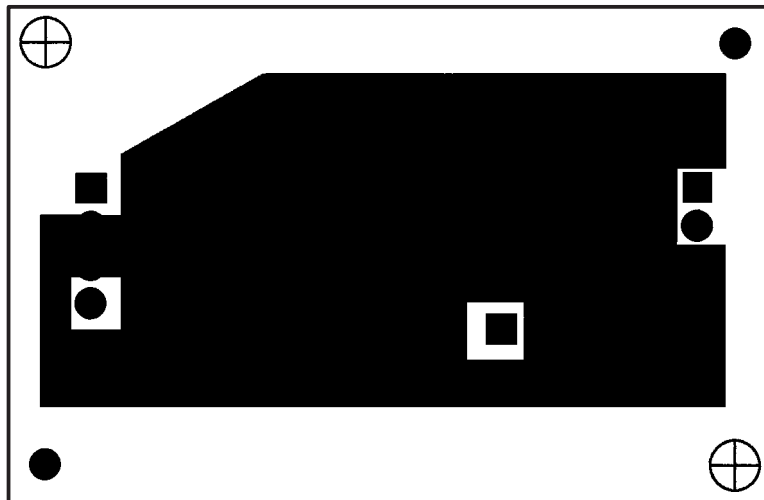

SOLDER SIDE

Figure 19. PC Wiring Side (Viewed From Component Side)

TPS6735 FIXED NEGATIVE 5-V 200-mA INVERTING DC/DC CONVERTER

SLVS141A – JULY 1996 – REVISED JANUARY 1997

MECHANICAL DATA

D (R-PDSO-G**)

PLASTIC SMALL-OUTLINE PACKAGE

14 PIN SHOWN

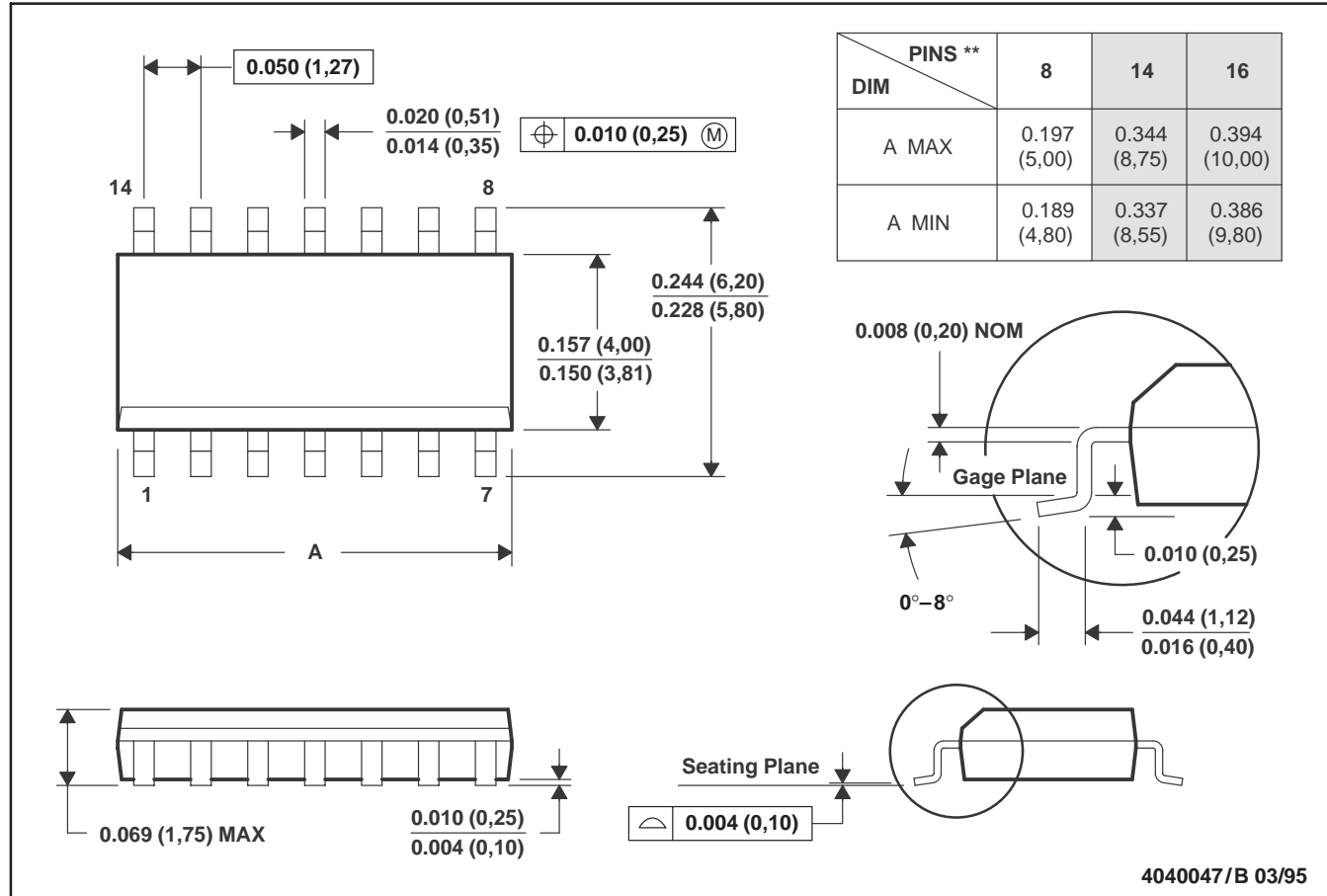

- NOTES: A. All linear dimensions are in inches (millimeters).
 B. This drawing is subject to change without notice.
 C. Body dimensions do not include mold flash or protrusion, not to exceed 0.006 (0,15).
 D. Four center pins are connected to die mount pad.
 E. Falls within JEDEC MS-012

TPS6735 FIXED NEGATIVE 5-V 200-mA INVERTING DC/DC CONVERTER

SLVS141A – JULY 1996 – REVISED JANUARY 1997

MECHANICAL DATA

P (R-PDIP-T8)

PLASTIC DUAL-IN-LINE PACKAGE

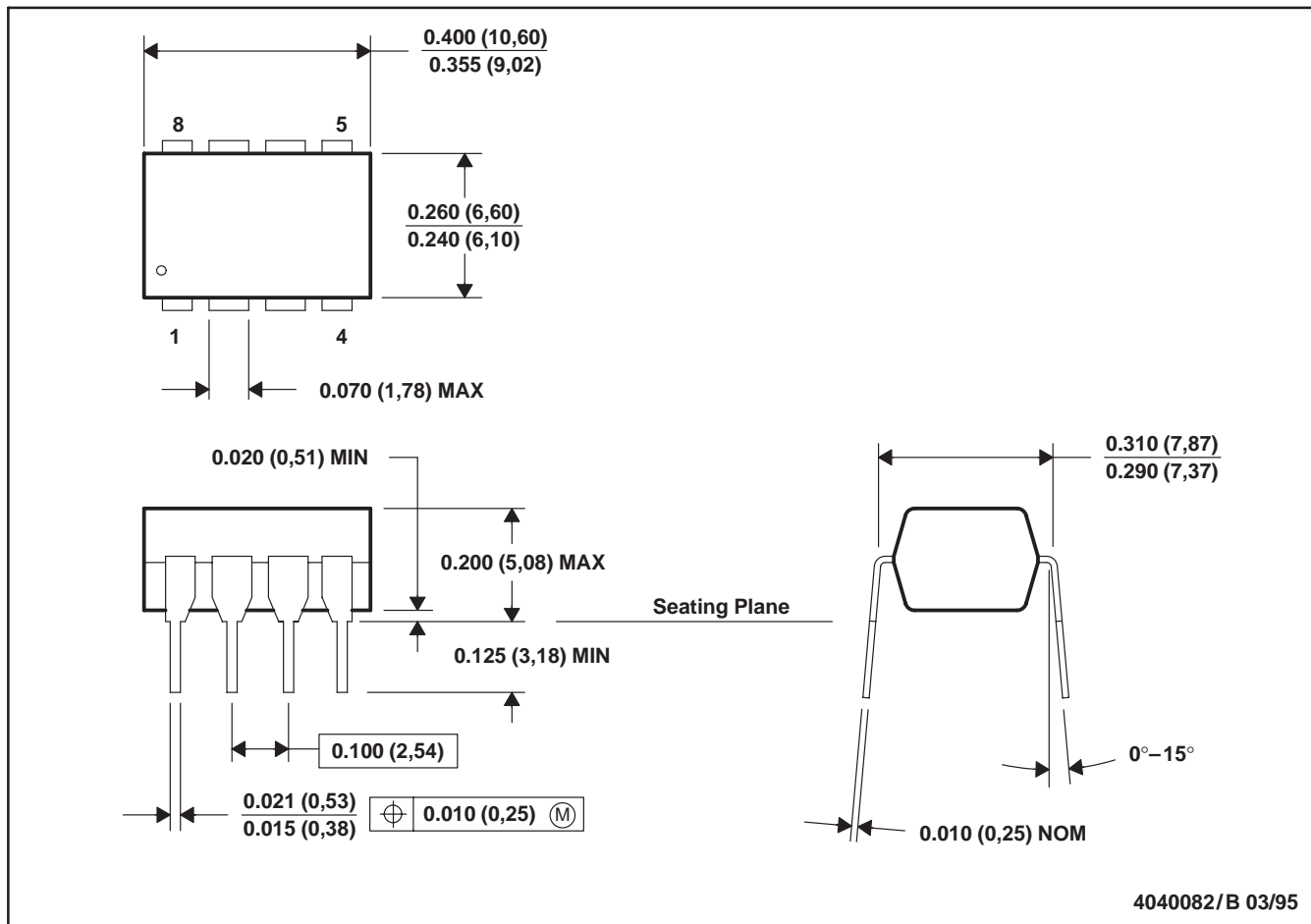

- NOTES: A. All linear dimensions are in inches (millimeters).
 B. This drawing is subject to change without notice.
 C. Falls within JEDEC MS-001

IMPORTANT NOTICE

Texas Instruments and its subsidiaries (TI) reserve the right to make changes to their products or to discontinue any product or service without notice, and advise customers to obtain the latest version of relevant information to verify, before placing orders, that information being relied on is current and complete. All products are sold subject to the terms and conditions of sale supplied at the time of order acknowledgement, including those pertaining to warranty, patent infringement, and limitation of liability.

TI warrants performance of its semiconductor products to the specifications applicable at the time of sale in accordance with TI's standard warranty. Testing and other quality control techniques are utilized to the extent TI deems necessary to support this warranty. Specific testing of all parameters of each device is not necessarily performed, except those mandated by government requirements.

CERTAIN APPLICATIONS USING SEMICONDUCTOR PRODUCTS MAY INVOLVE POTENTIAL RISKS OF DEATH, PERSONAL INJURY, OR SEVERE PROPERTY OR ENVIRONMENTAL DAMAGE ("CRITICAL APPLICATIONS"). TI SEMICONDUCTOR PRODUCTS ARE NOT DESIGNED, AUTHORIZED, OR WARRANTED TO BE SUITABLE FOR USE IN LIFE-SUPPORT DEVICES OR SYSTEMS OR OTHER CRITICAL APPLICATIONS. INCLUSION OF TI PRODUCTS IN SUCH APPLICATIONS IS UNDERSTOOD TO BE FULLY AT THE CUSTOMER'S RISK.

In order to minimize risks associated with the customer's applications, adequate design and operating safeguards must be provided by the customer to minimize inherent or procedural hazards.

TI assumes no liability for applications assistance or customer product design. TI does not warrant or represent that any license, either express or implied, is granted under any patent right, copyright, mask work right, or other intellectual property right of TI covering or relating to any combination, machine, or process in which such semiconductor products or services might be or are used. TI's publication of information regarding any third party's products or services does not constitute TI's approval, warranty or endorsement thereof.