

TPS2044, TPS2054 QUAD POWER-DISTRIBUTION SWITCHES

SLVS174A – JULY 1998 – REVISED OCTOBER 1998

- 135-mΩ -Maximum (5-V Input) High-Side MOSFET Switch
- 500 mA Continuous Current per Channel
- Short-Circuit Protection
- Independent Thermal Protection
- Overcurrent Logic Output
- Operating Range . . . 2.7-V to 5.5-V
- Logic-Level Enable Input
- 2.5-ms Typical Rise Time
- Undervoltage Lockout
- 20 μA Maximum Standby Supply Current
- Bidirectional Switch
- Available in 8-pin SOIC Package
- Ambient Temperature Range, –40°C to 85°C
- 2-kV Human-Body-Model, 200-V Machine-Model ESD Protection

description

The TPS2044 and TPS2054 quad power distribution switches are intended for applications where heavy capacitive loads and short circuits are likely to be encountered. Both the TPS2044 and the TPS2054 incorporate in a single package four 135-mΩ N-channel MOSFET high-side power switches for power distribution systems that require multiple power switches. Each switch is controlled by a logic enable that is compatible with 5-V logic and 3-V logic. Gate drive is provided by an internal charge pump that controls the power-switch rise times and fall times to minimize current surges during switching. The charge pump, requiring no external components, allows operation from supplies as low as 2.7 V.

When the output load exceeds the current-limit threshold or a short is present, the TPS2044 and TPS2054 limit the output current to a safe level by switching into a constant-current mode, pulling the overcurrent (\overline{OCx}) logic output low. When continuous heavy overloads and short circuits increase the power dissipation in the switch causing the junction temperature to rise, a thermal protection circuit shuts off the switch to prevent damage. Recovery from a thermal shutdown is automatic once the device has cooled sufficiently. Internal circuitry ensures the switch remains off until valid input voltage is present.

The TPS2044 and TPS2054 are designed to limit at 0.9-A load. These power distribution switches are available in 16-pin small-outline integrated circuit (SOIC) packages and operate over an ambient temperature range of –40°C to 85°C.

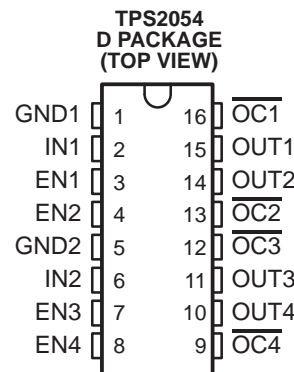
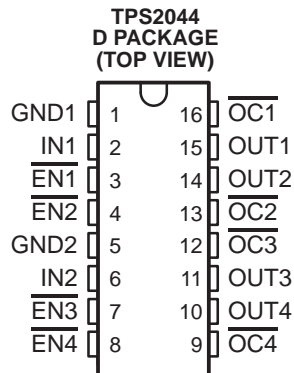

AVAILABLE OPTIONS

T _A	ENABLE	RECOMMENDED MAXIMUM CONTINUOUS LOAD CURRENT (A)	TYPICAL SHORT-CIRCUIT CURRENT LIMIT AT 25°C (A)	PACKAGED DEVICES
				SOIC (D)†
–40°C to 85°C	Active low	0.5	0.9	TPS2044D
–40°C to 85°C	Active high	0.5	0.9	TPS2054D

† The D package is available taped and reeled. Add an R suffix to device type (e.g., TPS2044DR)



Please be aware that an important notice concerning availability, standard warranty, and use in critical applications of Texas Instruments semiconductor products and disclaimers thereto appears at the end of this data sheet.

PRODUCTION DATA information is current as of publication date. Products conform to specifications per the terms of Texas Instruments standard warranty. Production processing does not necessarily include testing of all parameters.

 **TEXAS
INSTRUMENTS**

POST OFFICE BOX 655303 • DALLAS, TEXAS 75265

Copyright © 1998, Texas Instruments Incorporated

TPS2044, TPS2054 QUAD POWER-DISTRIBUTION SWITCHES

SLVS174A – JULY 1998 – REVISED OCTOBER 1998

TPS2044 functional block diagram

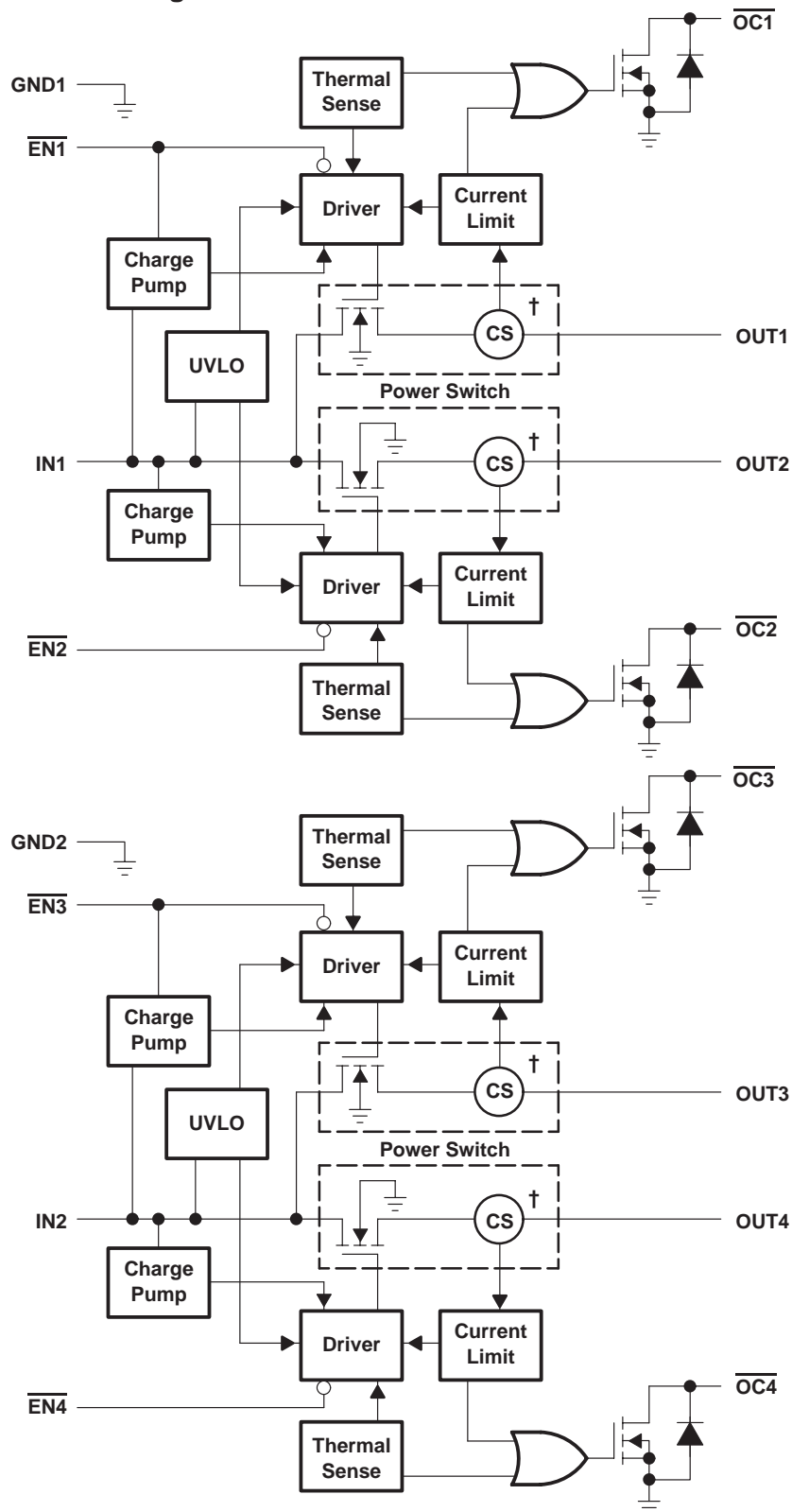

† Current sense



POST OFFICE BOX 655303 • DALLAS, TEXAS 75265

Terminal Functions

NAME	TERMINAL		I/O	DESCRIPTION
	NO.			
	TPS2044	TPS2054		
$\overline{\text{EN1}}$	3	–	I	Enable input, logic low turns on power switch, IN1-OUT1.
$\overline{\text{EN2}}$	4	–	I	Enable input, logic low turns on power switch, IN1-OUT2.
$\overline{\text{EN3}}$	7	–	I	Enable input, logic low turns on power switch, IN2-OUT3.
$\overline{\text{EN4}}$	8	–	I	Enable input, logic low turns on power switch, IN2-OUT4.
EN1	–	3	I	Enable input, logic high turns on power switch, IN1-OUT1.
EN2	–	4	I	Enable input, logic high turns on power switch, IN1-OUT2.
EN3	–	7	I	Enable input, logic high turns on power switch, IN2-OUT3.
EN4	–	8	I	Enable input, logic high turns on power switch, IN2-OUT4.
GND1	1	1		Ground, must be connected to GND2
GND2	5	5		Ground, must be connected to GND1
IN1	2	2	I	Input voltage, must be connected to IN2
IN2	6	6	I	Input voltage, must be connected to IN1
$\overline{\text{OC1}}$	16	16	O	Overcurrent. logic output active low, IN1-OUT1
$\overline{\text{OC2}}$	13	13	O	Overcurrent. logic output active low, IN1-OUT2
$\overline{\text{OC3}}$	12	12	O	Overcurrent. logic output active low, IN2-OUT3
$\overline{\text{OC4}}$	9	9	O	Overcurrent. logic output active low, IN2-OUT4
OUT1	15	15	O	Power-switch output, IN1-OUT1
OUT2	14	14	O	Power-switch output, IN1-OUT2
OUT3	11	11	O	Power-switch output, IN2-OUT3
OUT4	10	10	O	Power-switch output, IN2-OUT4

TPS2044, TPS2054

QUAD POWER-DISTRIBUTION SWITCHES

SLVS174A – JULY 1998 – REVISED OCTOBER 1998

detailed description

power switch

The power switch is an N-channel MOSFET with a maximum on-state resistance of 135 m Ω ($V_{I(INx)} = 5$ V). Configured as a high-side switch, the power switch prevents current flow from OUTx to INx and INx to OUTx when disabled. The power switch supplies a minimum of 500 mA per switch.

charge pump

An internal charge pump supplies power to the driver circuit and provides the necessary voltage to pull the gate of the MOSFET above the source. The charge pump operates from input voltages as low as 2.7 V and requires very little supply current.

driver

The driver controls the gate voltage of the power switch. To limit large current surges and reduce the associated electromagnetic interference (EMI) produced, the driver incorporates circuitry that controls the rise times and fall times of the output voltage. The rise and fall times are typically in the 2-ms to 4-ms range.

enable (\overline{ENx} or ENx)

The logic enable disables the power switch and the bias for the charge pump, driver, and other circuitry to reduce the supply current to less than 20 μ A when a logic high is present on ENx (TPS2044) or a logic low is present on ENx (TPS2054). A logic zero input on \overline{ENx} or logic high on ENx restores bias to the drive and control circuits and turns the power on. The enable input is compatible with both TTL and CMOS logic levels.

overcurrent (\overline{OCx})

The \overline{OCx} open drain output is asserted (active low) when an overcurrent or over temperature condition is encountered. The output will remain asserted until the overcurrent or over temperature condition is removed.

current sense

A sense FET monitors the current supplied to the load. The sense FET measures current more efficiently than conventional resistance methods. When an overload or short circuit is encountered, the current-sense circuitry sends a control signal to the driver. The driver in turn reduces the gate voltage and drives the power FET into its saturation region, which switches the output into a constant current mode and holds the current constant while varying the voltage on the load.

thermal sense

The TPS2044 and TPS2054 implement a dual thermal trip to allow fully independent operation of the power distribution switches. In an overcurrent or short-circuit condition the junction temperature rises. When the die temperature rises to approximately 140°C, the internal thermal sense circuitry checks to determine which power switch is in an overcurrent condition and turns off that switch, thus, isolating the fault without interrupting operation of the adjacent power switch. Hysteresis is built into the thermal sense, and after the device has cooled approximately 20 degrees, the switch turns back on. The switch continues to cycle off and on until the fault is removed. The (\overline{OCx}) open-drain output is asserted (active low) when overtemperature or overcurrent occurs.

undervoltage lockout

A voltage sense circuit monitors the input voltage. When the input voltage is below approximately 2 V, a control signal turns off the power switch.



POST OFFICE BOX 655303 • DALLAS, TEXAS 75265

absolute maximum ratings over operating free-air temperature range (unless otherwise noted)†

Input voltage range, $V_{I(INx)}$ (see Note1)	-0.3 V to 6 V
Output voltage range, $V_{O(OUTx)}$ (see Note1)	-0.3 V to $V_{I(INx)} + 0.3$ V
Input voltage range, $V_{I(ENx)}$ or $V_{I(ENx)}$	-0.3 V to 6 V
Continuous output current, $I_{O(OUTx)}$	Internally limited
Continuous total power dissipation	See Dissipation Rating Table
Operating virtual junction temperature range, T_J	-40°C to 125°C
Storage temperature range, T_{stg}	-65°C to 150°C
Lead temperature soldering 1,6 mm (1/16 inch) from case for 10 seconds	260°C

† Stresses beyond those listed under “absolute maximum ratings” may cause permanent damage to the device. These are stress ratings only, and functional operation of the device at these or any other conditions beyond those indicated under “recommended operating conditions” is not implied. Exposure to absolute-maximum-rated conditions for extended periods may affect device reliability.

NOTE 1: All voltages are with respect to GND.

DISSIPATION RATING TABLE

PACKAGE	$T_A \leq 25^\circ\text{C}$ POWER RATING	DERATING FACTOR ABOVE $T_A = 25^\circ\text{C}$	$T_A = 70^\circ\text{C}$ POWER RATING	$T_A = 85^\circ\text{C}$ POWER RATING
D	725 mW	5.8 mW/°C	464 mW	377 mW

recommended operating conditions

		TPS2044		TPS2054		UNIT
		MIN	MAX	MIN	MAX	
Input voltage, $V_{I(INx)}$		2.7	5.5	2.7	5.5	V
Input voltage, $V_{I(ENx)}$ or $V_{I(ENx)}$		0	5.5	0	5.5	V
Continuous output current, I_O	OUT1	0	500	0	500	mA
	OUT2	0	500	0	500	
	OUT3	0	500	0	500	
	OUT4	0	500	0	500	
Operating virtual junction temperature, T_J		-40	125	-40	125	°C

electrostatic discharge (ESD) protection

		UNIT
Human body model MIL-STD-883C	2	kV
Machine model	0.2	kV

TPS2044, TPS2054 QUAD POWER-DISTRIBUTION SWITCHES

SLVS174A – JULY 1998 – REVISED OCTOBER 1998

electrical characteristics over recommended operating junction temperature range, $V_{I(IN)} = 5.5\text{ V}$, $I_O = \text{rated current}$, $V_{I(ENx)} = 0\text{ V}$ (unless otherwise noted)

power switch

PARAMETER		TEST CONDITIONS†	TPS2044			TPS2054			UNIT
			MIN	TYP	MAX	MIN	TYP	MAX	
$r_{DS(on)}$	Static drain-source on-state resistance	$V_{I(INx)} = 5\text{ V}$, $T_J = 25^\circ\text{C}$, $I_O = 0.5\text{ A}$	80	95		80	95	m Ω	
		$V_{I(INx)} = 5\text{ V}$, $T_J = 85^\circ\text{C}$, $I_O = 0.5\text{ A}$	90	120		90	120		
		$V_{I(INx)} = 5\text{ V}$, $T_J = 125^\circ\text{C}$, $I_O = 0.5\text{ A}$	100	135		100	135		
		$V_{I(INx)} = 3.3\text{ V}$, $T_J = 25^\circ\text{C}$, $I_O = 0.5\text{ A}$	85	105		85	105		
		$V_{I(INx)} = 3.3\text{ V}$, $T_J = 85^\circ\text{C}$, $I_O = 0.5\text{ A}$	100	135		100	135		
		$V_{I(INx)} = 3.3\text{ V}$, $T_J = 125^\circ\text{C}$, $I_O = 0.5\text{ A}$	115	150		115	150		
t_r	Rise time, output	$V_{I(INx)} = 5.5\text{ V}$, $T_J = 25^\circ\text{C}$, $C_L = 1\text{ }\mu\text{F}$, $R_L = 10\text{ }\Omega$	2.5			2.5		ms	
		$V_{I(INx)} = 2.7\text{ V}$, $T_J = 25^\circ\text{C}$, $C_L = 1\text{ }\mu\text{F}$, $R_L = 10\text{ }\Omega$	3			3			
t_f	Fall time, output	$V_{I(INx)} = 5.5\text{ V}$, $T_J = 25^\circ\text{C}$, $C_L = 1\text{ }\mu\text{F}$, $R_L = 10\text{ }\Omega$	4.4			4.4		ms	
		$V_{I(INx)} = 2.7\text{ V}$, $T_J = 25^\circ\text{C}$, $C_L = 1\text{ }\mu\text{F}$, $R_L = 10\text{ }\Omega$	2.5			2.5			

† Pulse-testing techniques maintain junction temperature close to ambient temperature; thermal effects must be taken into account separately.

enable input $V_{I(\overline{ENx})}$ or $V_{I(ENx)}$

PARAMETER		TEST CONDITIONS	TPS2044			TPS2054			UNIT
			MIN	TYP	MAX	MIN	TYP	MAX	
V_{IH}	High-level input voltage	$2.7\text{ V} \leq V_{I(INx)} \leq 5.5\text{ V}$	2			2			V
V_{IL}	Low-level input voltage	$4.5\text{ V} \leq V_{I(INx)} \leq 5.5\text{ V}$			0.8			0.8	V
		$2.7\text{ V} \leq V_{I(INx)} \leq 4.5\text{ V}$			0.4			0.4	
I_I	Input current	TPS2044 $V_{I(ENx)} = 0\text{ V}$ or $V_{I(ENx)} = V_{I(IN)}$	-0.5		0.5				μA
		TPS2054 $V_{I(ENx)} = V_{I(INx)}$ or $V_{I(ENx)} = 0\text{ V}$				-0.5		0.5	
t_{on}	Turn-on time	$C_L = 100\text{ }\mu\text{F}$, $R_L = 10\text{ }\Omega$			20			20	ms
t_{off}	Turn-off time	$C_L = 100\text{ }\mu\text{F}$, $R_L = 10\text{ }\Omega$			40			40	ms

current limit

PARAMETER		TEST CONDITIONS†	TPS2044			TPS2054			UNIT
			MIN	TYP	MAX	MIN	TYP	MAX	
I_{OS}	Short-circuit output current	$V_{I(INx)} = 5\text{ V}$, OUT connected to GND, Device enable into short circuit, See Figures 6–8, 12–14, and 33.	0.7	0.9	1.1	0.7	0.9	1.1	A

† Pulse-testing techniques maintain junction temperature close to ambient temperature; thermal effects must be taken into account separately.



TPS2044, TPS2054 QUAD POWER-DISTRIBUTION SWITCHES

SLVS174A – JULY 1998 – REVISED OCTOBER 1998

electrical characteristics over recommended operating junction temperature range, $V_{I(IN)} = 5.5\text{ V}$, $I_O = \text{rated current}$, $V_{I(ENx)} = 0\text{ V}$ (unless otherwise noted) (continued)

supply current

PARAMETER	TEST CONDITIONS			TPS2044			TPS2054			UNIT
				MIN	TYP	MAX	MIN	TYP	MAX	
Supply current, low-level output	No Load on OUTx	$\overline{V_{I(ENx)}} = V_{I(INx)}$	$T_J = 25^\circ\text{C}$	TPS2044	0.03	2				μA
			$-40^\circ\text{C} \leq T_J \leq 125^\circ\text{C}$			20				
		$V_{I(ENx)} = 0\text{ V}$	$T_J = 25^\circ\text{C}$	TPS2054			0.03	2		
			$-40^\circ\text{C} \leq T_J \leq 125^\circ\text{C}$					20		
Supply current, high-level output	No Load on OUTx	$V_{I(ENx)} = 0\text{ V}$	$T_J = 25^\circ\text{C}$	TPS2044	160	200			μA	
			$-40^\circ\text{C} \leq T_J \leq 125^\circ\text{C}$			200				
		$V_{I(ENx)} = V_{I(INx)}$	$T_J = 25^\circ\text{C}$	TPS2054			160	200		
			$-40^\circ\text{C} \leq T_J \leq 125^\circ\text{C}$					200		
Leakage current	OUTx connected to ground	$\overline{V_{I(ENx)}} = V_{I(INx)}$	$-40^\circ\text{C} \leq T_J \leq 125^\circ\text{C}$	TPS2044	200				μA	
		$V_{I(ENx)} = 0\text{ V}$	$-40^\circ\text{C} \leq T_J \leq 125^\circ\text{C}$	TPS2054			200			

undervoltage lockout

PARAMETER	TEST CONDITIONS	TPS2044			TPS2054			UNIT
		MIN	TYP	MAX	MIN	TYP	MAX	
Low-level input voltage		2		2.5	2		2.5	V
Hysteresis	$T_J = 25^\circ\text{C}$		100			100		mV

overcurrent \overline{OCx} (see Figure 34)

PARAMETER	TEST CONDITIONS	TPS2044			TPS2054			UNIT
		MIN	TYP	MAX	MIN	TYP	MAX	
Sink current [†]	$V_O = 5\text{ V}$			10			10	mA
Output low voltage	$I_O = 5\text{ mA}$, $\overline{V_{OL(OCx)}}$			0.5			0.5	V
Off-state current [†]	$V_O = 5\text{ V}$, $V_O = 3.3\text{ V}$			1			1	μA

[†] Specified by design, not production tested.

TPS2044, TPS2054 QUAD POWER-DISTRIBUTION SWITCHES

SLVS174A – JULY 1998 – REVISED OCTOBER 1998

PARAMETER MEASUREMENT INFORMATION

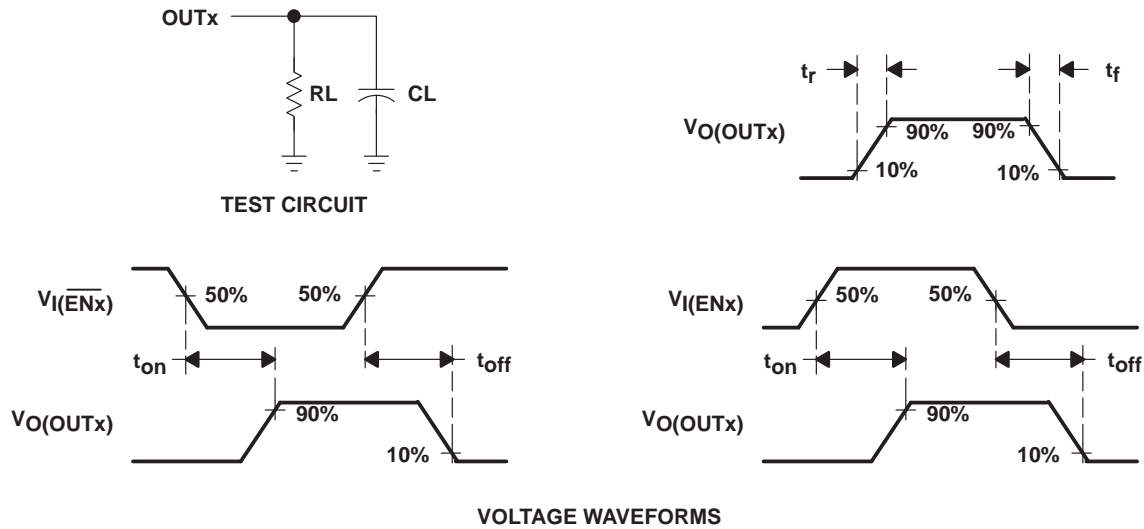

Figure 1. Test Circuit and Voltage Waveforms

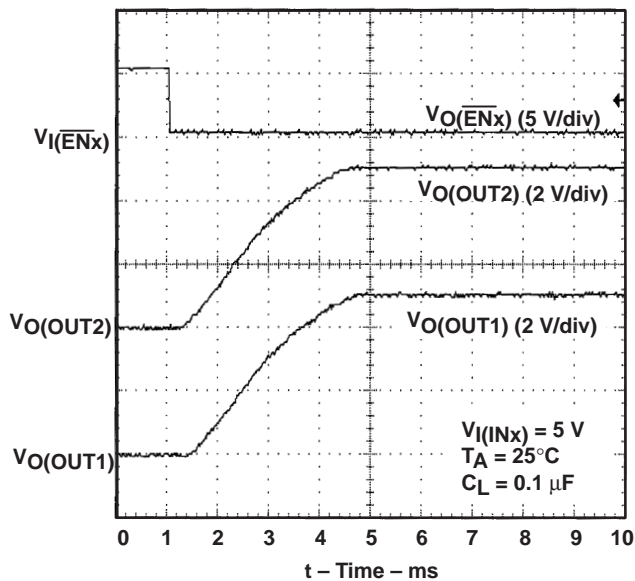

Figure 2. Turn-on Delay and Rise Time with 0.1- μ F Load

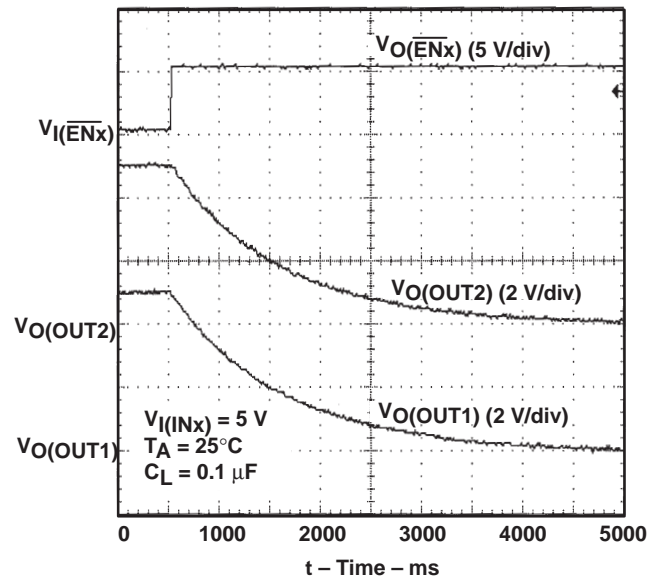

Figure 3. Turn-off Delay and Fall Time with 0.1- μ F Load

PARAMETER MEASUREMENT INFORMATION

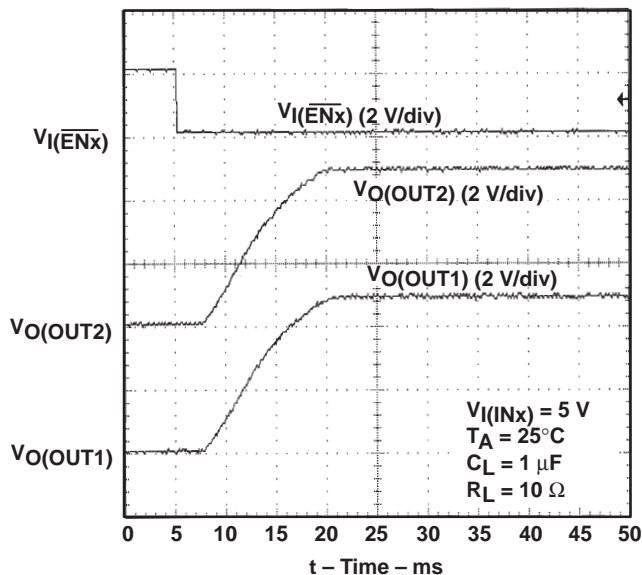

Figure 4. Turn-on Delay and Rise Time with 1- μ F Load

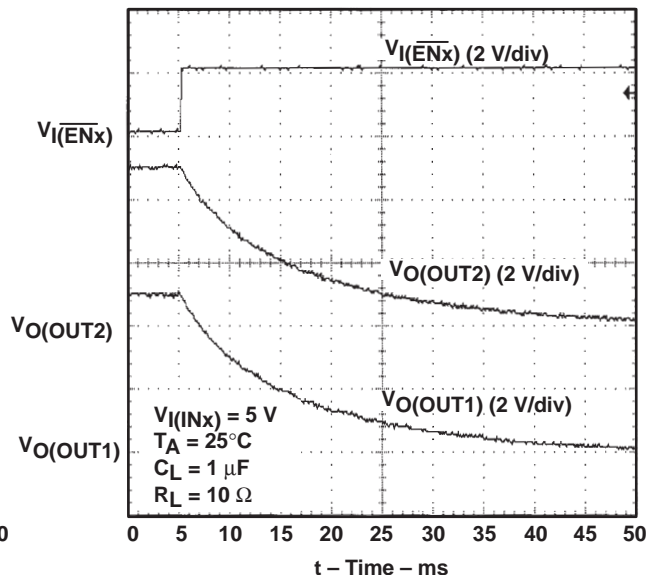

Figure 5. Turn-off Delay and Fall Time with 1- μ F Load

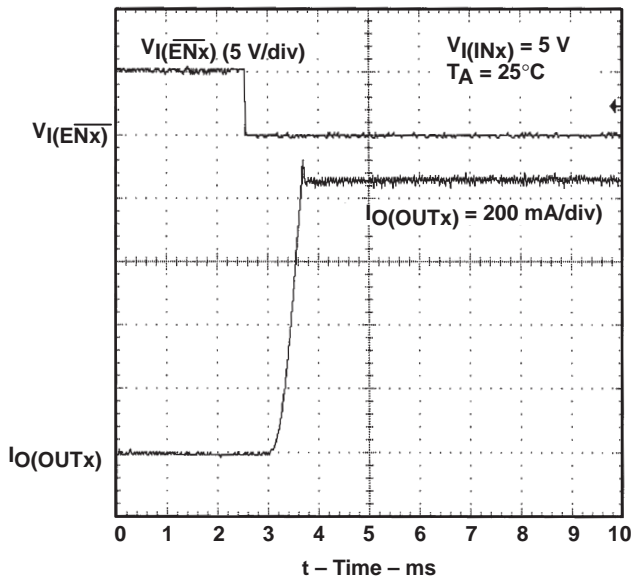

Figure 6. TPS2044, Short-Circuit Current, Device Enabled into Short

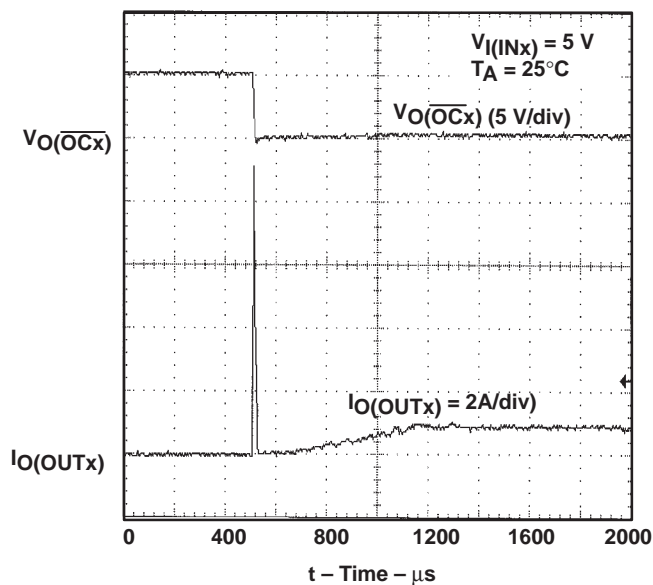

Figure 7. TPS2044, Short Connected to Enabled Device

TPS2044, TPS2054 QUAD POWER-DISTRIBUTION SWITCHES

SLVS174A – JULY 1998 – REVISED OCTOBER 1998

PARAMETER MEASUREMENT INFORMATION

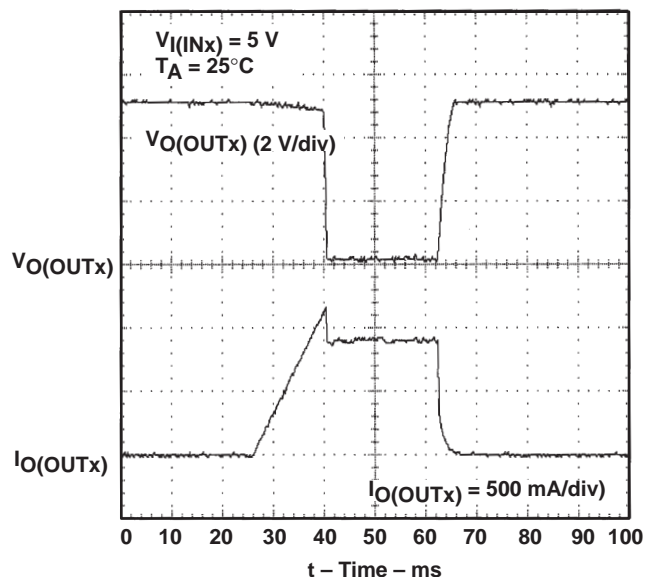

Figure 8. TPS2044, Threshold Trip Current with Ramped Load on Enabled Device

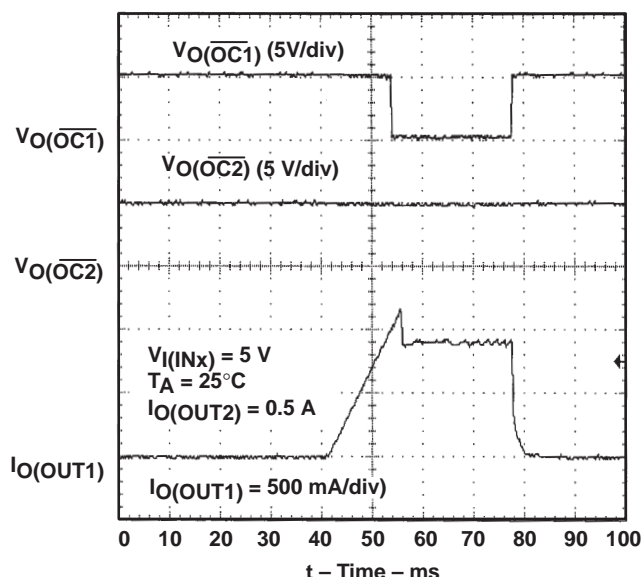

Figure 9. TPS2044, $\overline{OC1}$ and $\overline{OC2}$ Response with Ramped Load on OUT1 and Fixed Load on OUT2

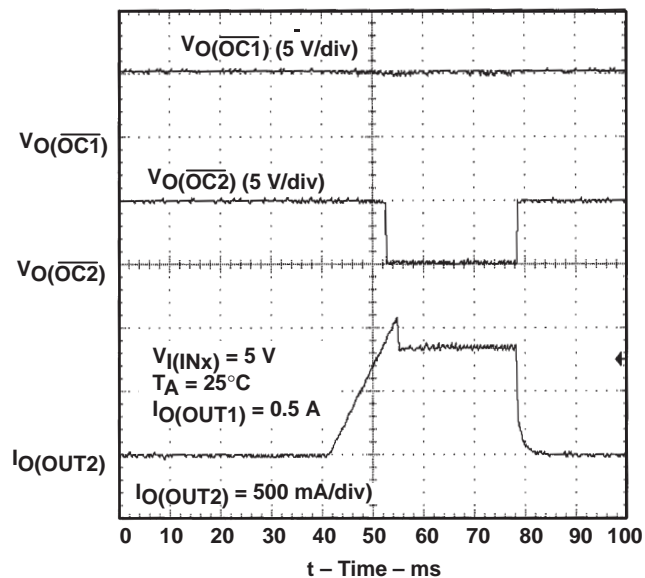

Figure 10. TPS2044, $\overline{OC1}$ and $\overline{OC2}$ Response with Ramped Load on OUT2 and Fixed Load on OUT1

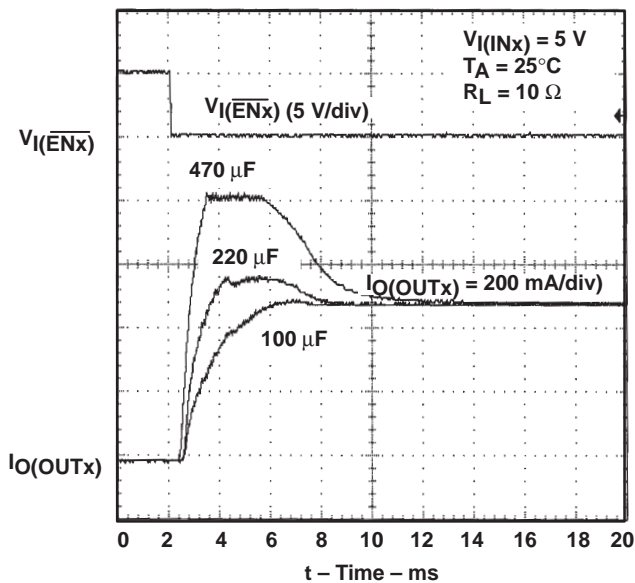

Figure 11. Inrush Current with 100- μ F, 220- μ F and 470- μ F Load Capacitance

PARAMETER MEASUREMENT INFORMATION

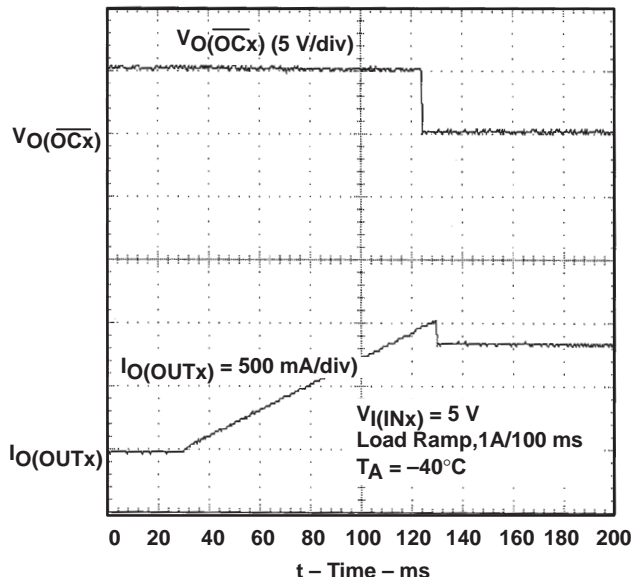

Figure 12. Ramped Load on Enabled Device

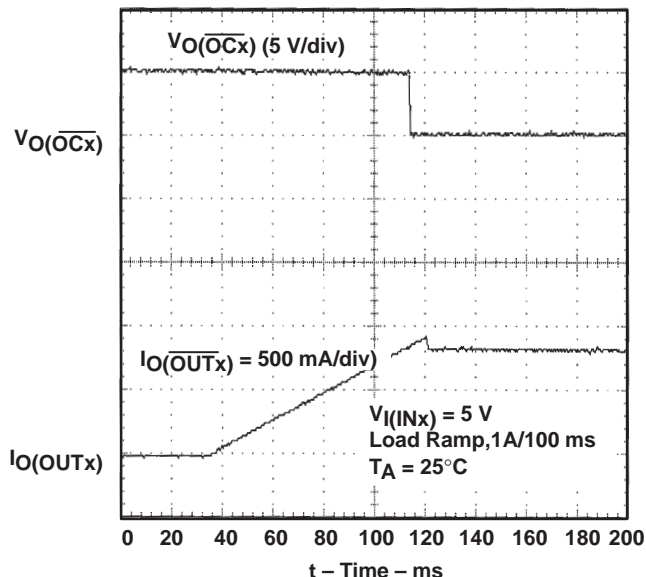

Figure 13. Ramped Load on Enabled Device

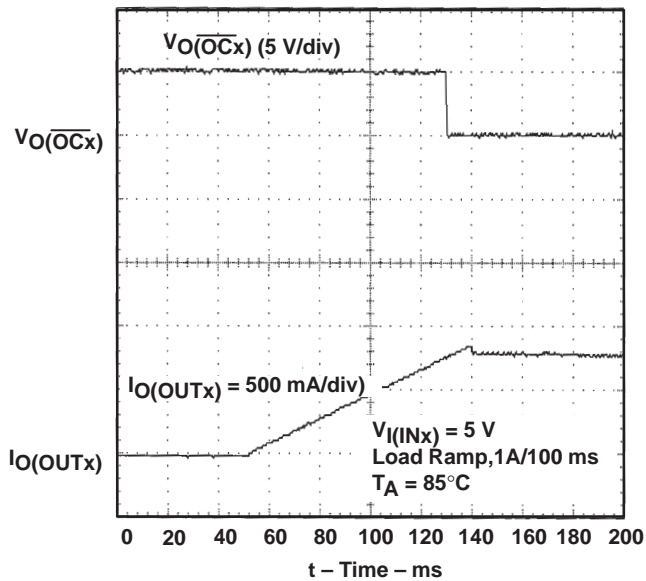

Figure 14. Ramped Load on Enabled Device

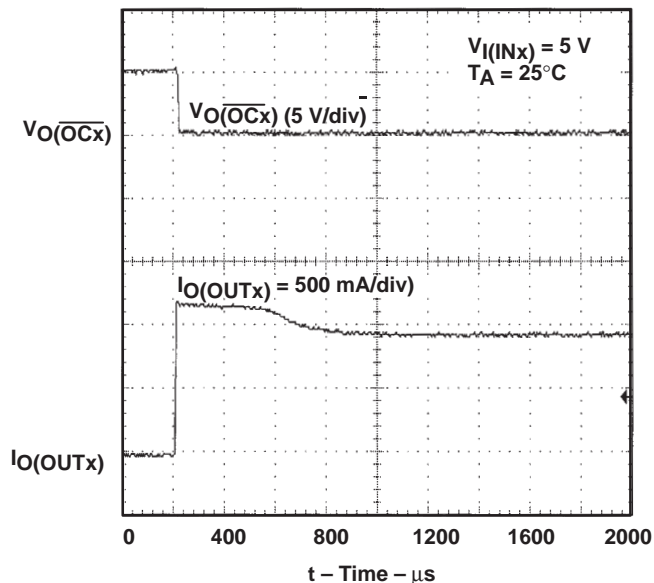

Figure 15. 4-Ω Load Connected to Enabled Device

TPS2044, TPS2054 QUAD POWER-DISTRIBUTION SWITCHES

SLVS174A – JULY 1998 – REVISED OCTOBER 1998

PARAMETER MEASUREMENT INFORMATION

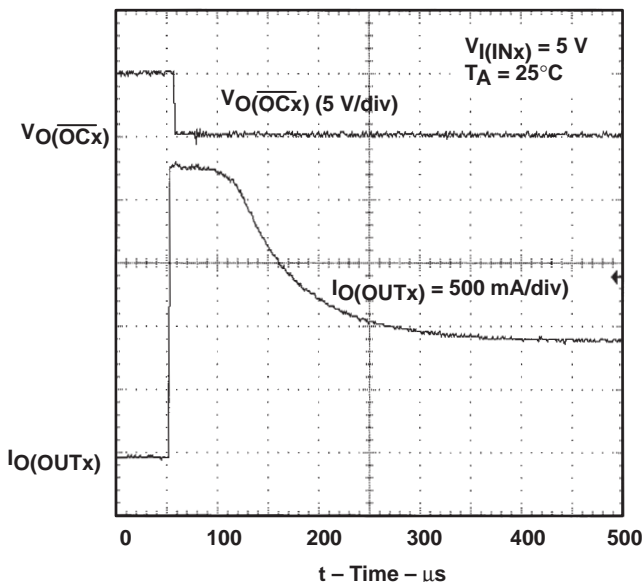

Figure 16. 2-Ω Load Connected to Enabled Device

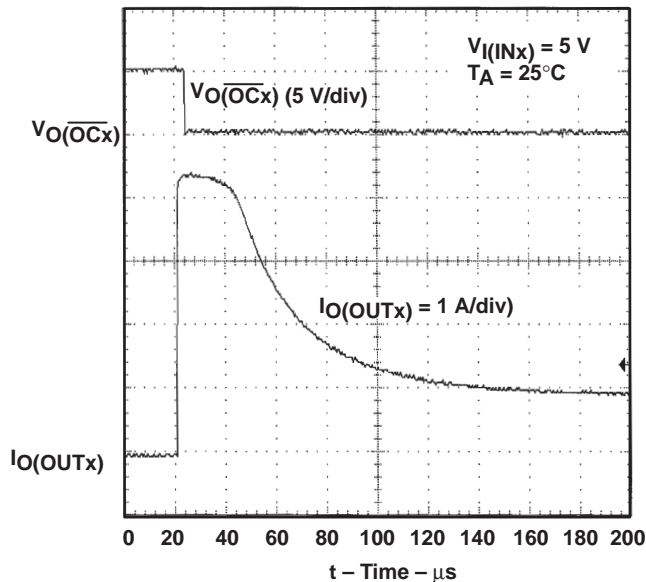

Figure 17. 1-Ω Load Connected to Enabled Device

TYPICAL CHARACTERISTICS

TURN-ON DELAY
vs
INPUT VOLTAGE

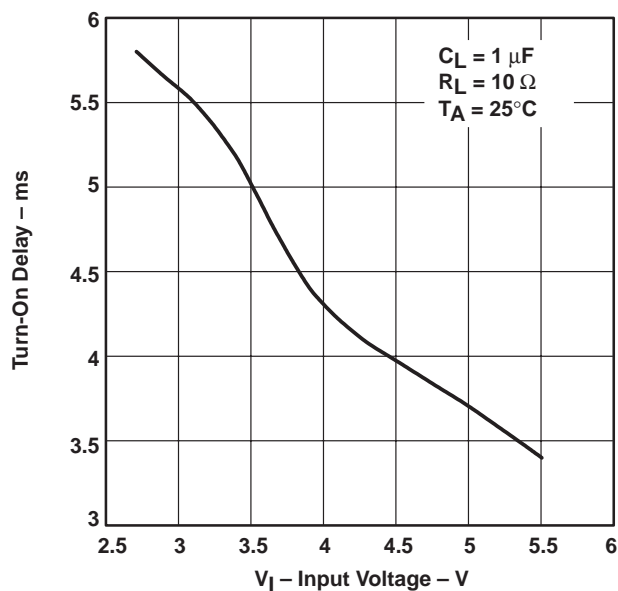

Figure 18

TURN-OFF DELAY
vs
INPUT VOLTAGE

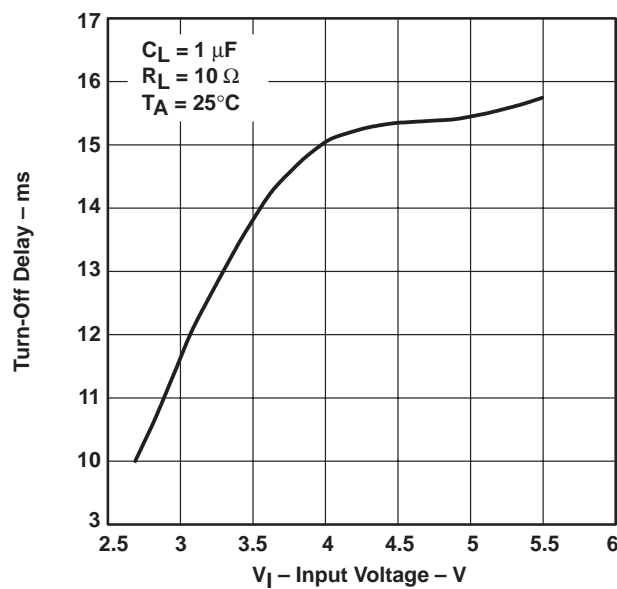
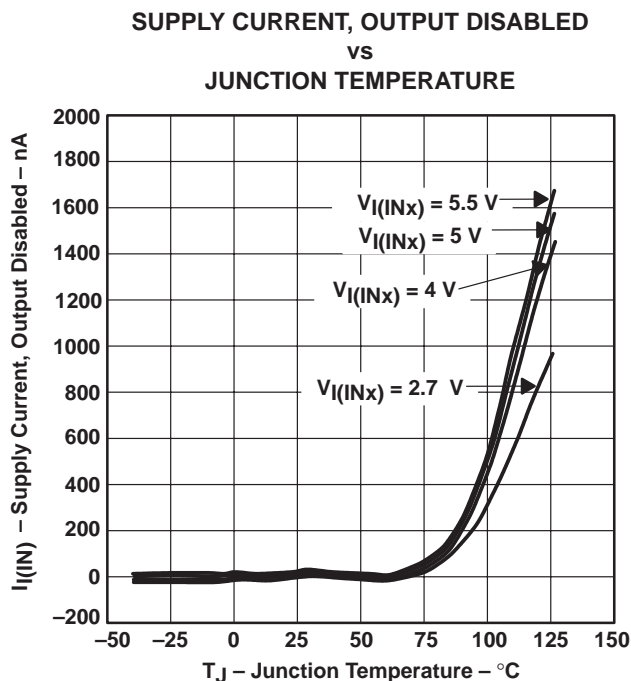
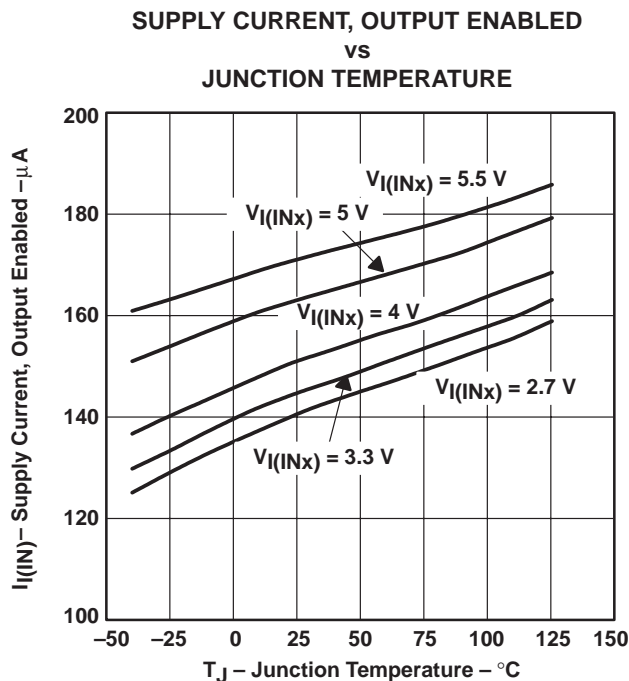
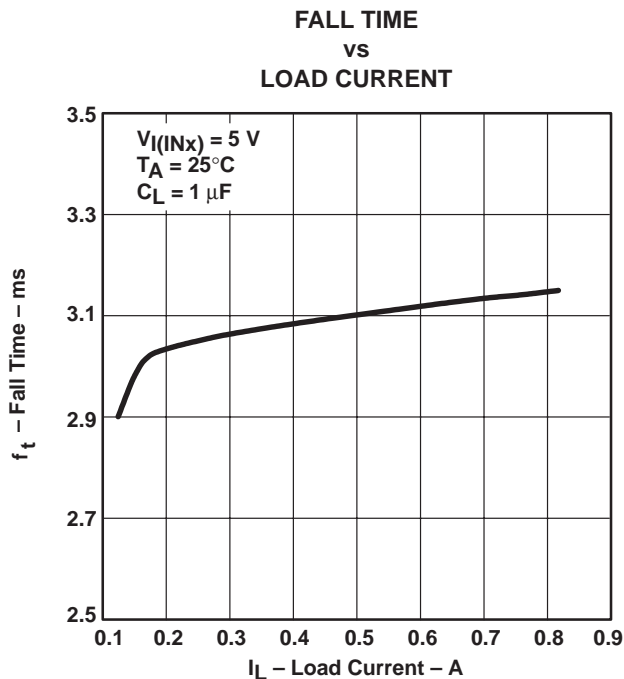
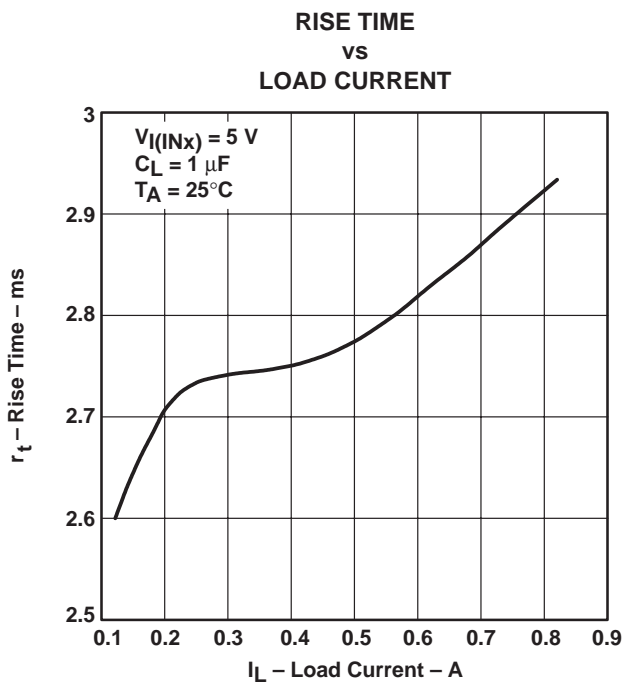

Figure 19



TYPICAL CHARACTERISTICS



TPS2044, TPS2054 QUAD POWER-DISTRIBUTION SWITCHES

SLVS174A – JULY 1998 – REVISED OCTOBER 1998

TYPICAL CHARACTERISTICS

**SUPPLY CURRENT, OUTPUT ENABLED
vs
INPUT VOLTAGE**

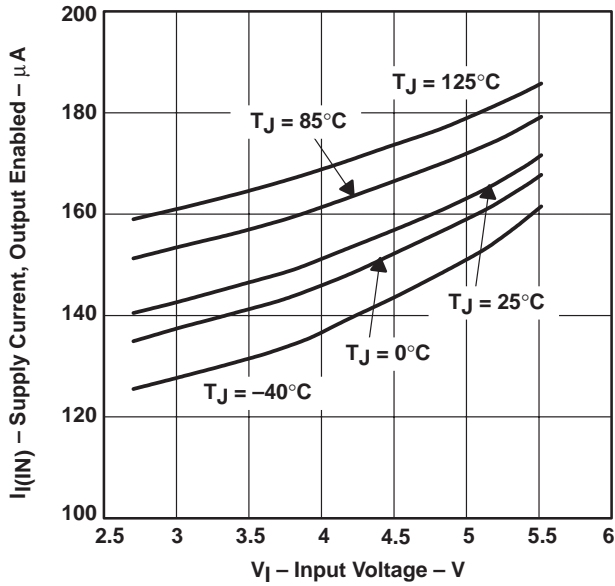

Figure 24

**SUPPLY CURRENT, OUTPUT DISABLED
vs
INPUT VOLTAGE**

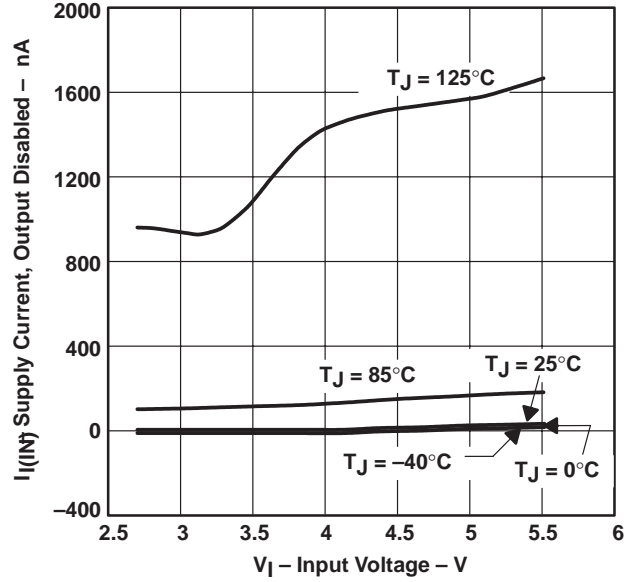

Figure 25

**STATIC DRAIN-SOURCE ON-STATE RESISTANCE
vs
JUNCTION TEMPERATURE**

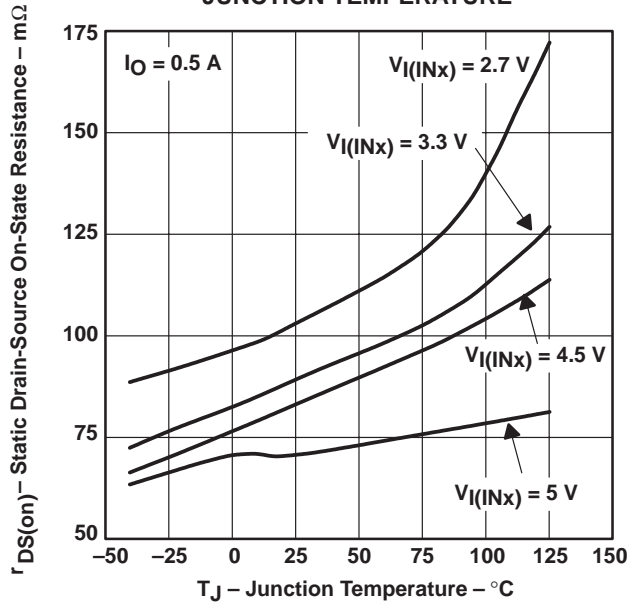

Figure 26

**STATIC DRAIN-SOURCE ON-STATE RESISTANCE
vs
INPUT VOLTAGE**

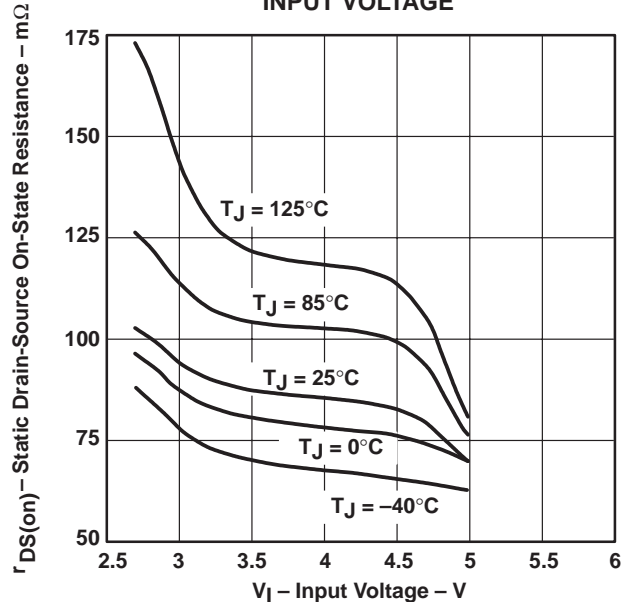

Figure 27

TYPICAL CHARACTERISTICS

INPUT-TO-OUTPUT VOLTAGE
 vs
 LOAD CURRENT

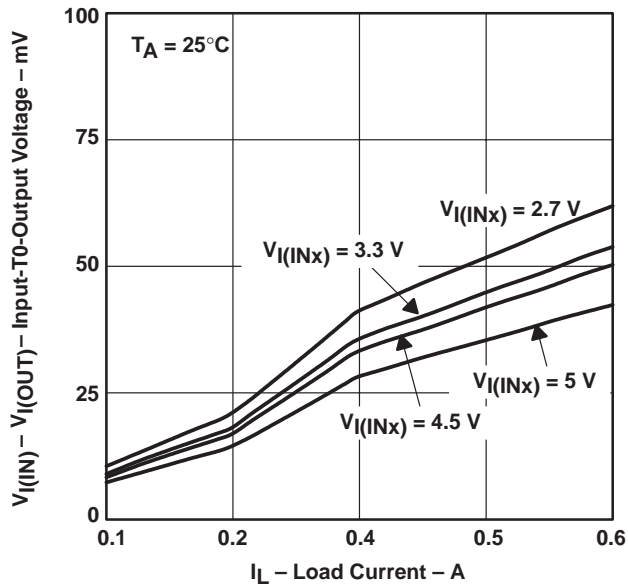

Figure 28

SHORT-CIRCUIT OUTPUT CURRENT
 vs
 INPUT VOLTAGE

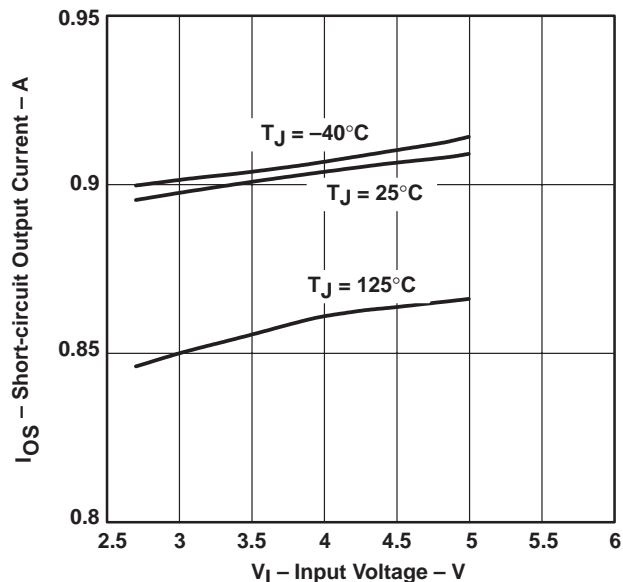

Figure 29

THRESHOLD TRIP CURRENT
 vs
 INPUT VOLTAGE

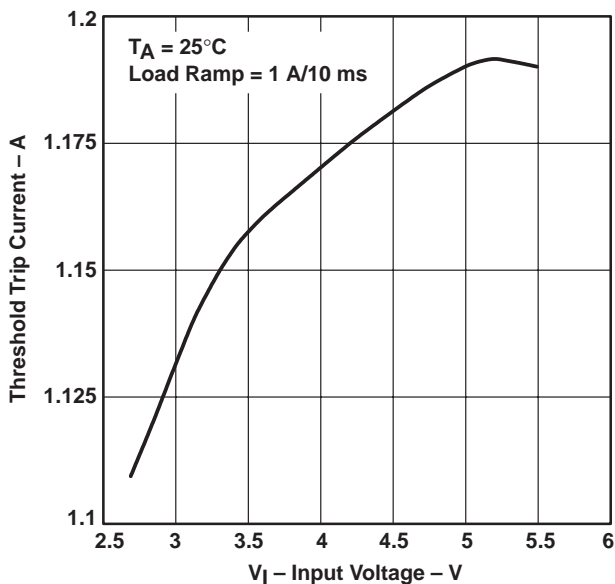

Figure 30

SHORT CIRCUIT OUTPUT CURRENT
 vs
 JUNCTION TEMPERATURE

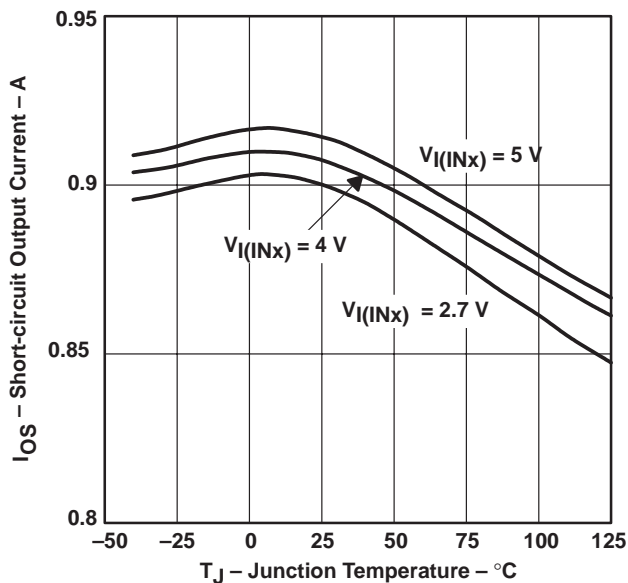

Figure 31

TYPICAL CHARACTERISTICS

UNDERVOLTAGE LOCKOUT
 vs
 JUNCTION TEMPERATURE

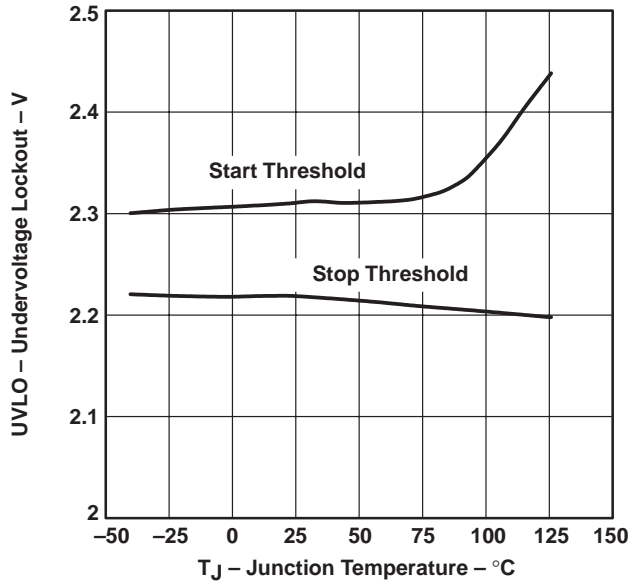

Figure 32

CURRENT LIMIT RESPONSE
 vs
 PEAK CURRENT

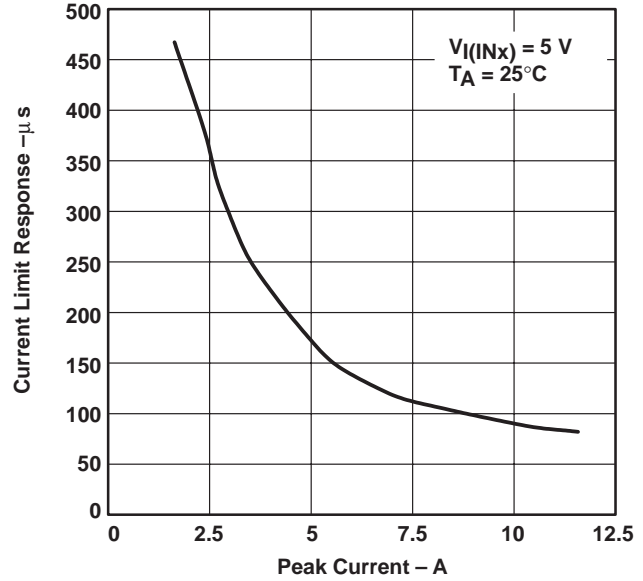

Figure 33

OVERCURRENT RESPONSE TIME (\overline{OCx})
 vs
 PEAK CURRENT

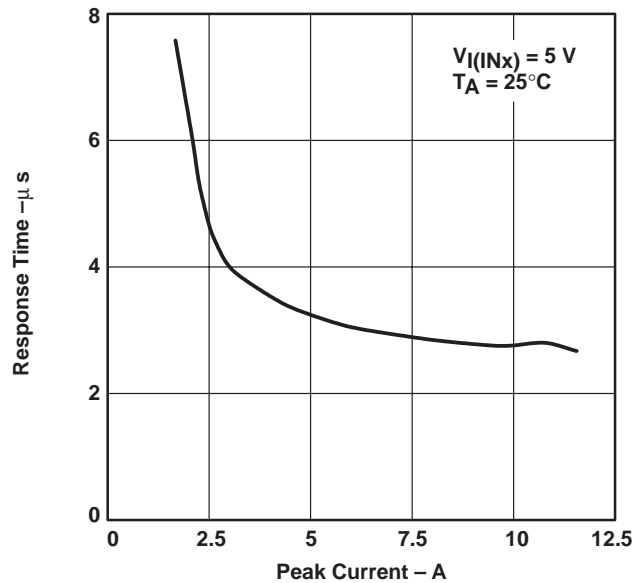

Figure 34

APPLICATION INFORMATION

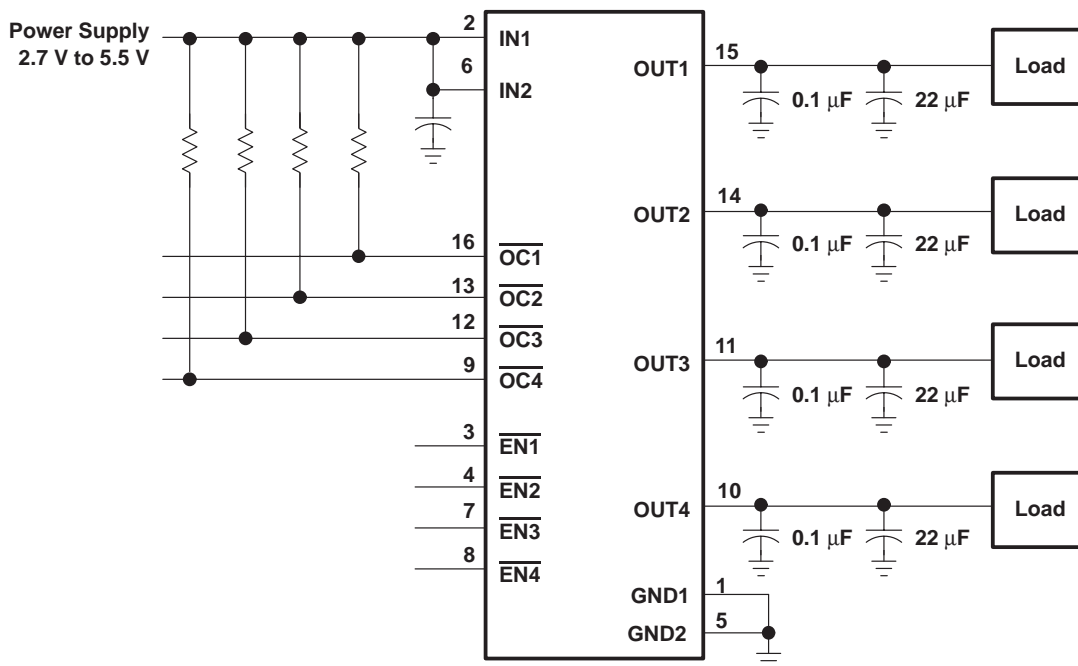

Figure 35. Typical Application

power supply considerations

A 0.01-µF to 0.1-µF ceramic bypass capacitor between IN_x and GND, close to the device, is recommended. When the output load is heavy, placing a high-value electrolytic capacitor on the output pin(s) to reduce power supply transients that may cause ringing on the input is also desirable. Additionally, bypassing the output with a 0.01-µF to 0.1-µF ceramic capacitor improves the immunity of the device to short-circuit transients.

overcurrent

A sense FET checks for overcurrent conditions. Unlike current-sense resistors, sense FETs do not increase the series resistance of the current path. When an overcurrent condition is detected, the device maintains a constant output current and reduces the output voltage accordingly. Complete shutdown occurs only if the fault is present long enough to activate thermal limiting.

Three possible overload conditions can occur. In the first condition, the output has been shorted before the device is enabled or before $V_{I(INX)}$ has been applied (see Figure 6). The TPS2044 and TPS2054 sense the short and immediately switch into a constant-current output.

In the second condition, the short occurs while the device is enabled. At the instant the short occurs, very high currents may flow for a short time before the current-limit circuit can react (see Figure 7). After the current-limit circuit has tripped (reached the overcurrent trip threshold) the device switches into constant-current mode.

In the third condition, the load has been gradually increased beyond the recommended operating current. The current is permitted to rise until the current-limit threshold is reached or until the thermal limit of the device is exceeded (see Figure 8). The TPS2044 and TPS2054 are capable of delivering current up to the current-limit threshold without damaging the device. Once the threshold has been reached, the device switches into its constant-current mode.

TPS2044, TPS2054 QUAD POWER-DISTRIBUTION SWITCHES

SLVS174A – JULY 1998 – REVISED OCTOBER 1998

APPLICATION INFORMATION

\overline{OC} response

The \overline{OC} open-drain output is asserted (active low) when an overcurrent or overtemperature condition is encountered. The output will remain asserted until the overcurrent or overtemperature condition is removed. Connecting a heavy capacitive load to an enabled device can cause momentary false overcurrent reporting from the inrush current flowing through the device, charging the downstream capacitor. An RC filter of 500 μ s (see Figure 36) can be connected to the \overline{OC} pin to reduce false overcurrent reporting. Using low-ESR electrolytic capacitors on the output lowers the inrush current flow through the device during hot-plug events by providing a low impedance energy source, thereby reducing erroneous overcurrent reporting.

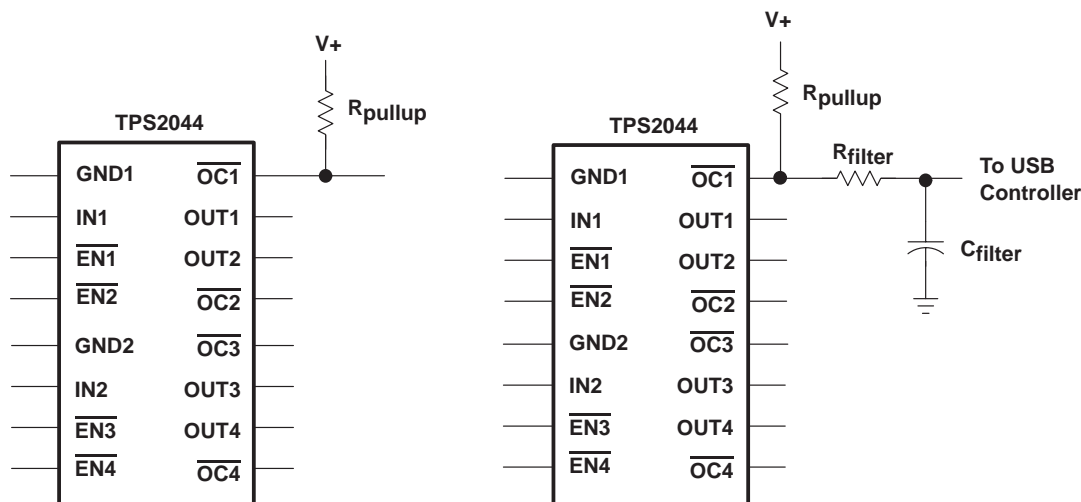

Figure 36. Typical Circuit for \overline{OC} Pin and RC Filter for Damping Inrush \overline{OC} Responses

power dissipation and junction temperature

The low on-resistance on the n-channel MOSFET allows small surface-mount packages, such as SOIC, to pass large currents. The thermal resistances of these packages are high compared to that of power packages; it is good design practice to check power dissipation and junction temperature. The first step is to find $r_{DS(on)}$ at the input voltage and operating temperature. As an initial estimate, use the highest operating ambient temperature of interest and read $r_{DS(on)}$ from Figure 27. Next, calculate the power dissipation using:

$$P_D = r_{DS(on)} \times I^2$$

Finally, calculate the junction temperature:

$$T_J = P_D \times R_{\theta JA} + T_A$$

Where:

T_A = Ambient Temperature °C

$R_{\theta JA}$ = Thermal resistance SOIC = 172°C/W, PDIP = 106°C/W

Compare the calculated junction temperature with the initial estimate. If they do not agree within a few degrees, repeat the calculation, using the calculated value as the new estimate. Two or three iterations are generally sufficient to get a reasonable answer.

APPLICATION INFORMATION

thermal protection

Thermal protection prevents damage to the IC when heavy-overload or short-circuit faults are present for extended periods of time. The faults force the TPS2044 and TPS2054 into constant current mode, which causes the voltage across the high-side switch to increase; under short-circuit conditions, the voltage across the switch is equal to the input voltage. The increased dissipation causes the junction temperature to rise to high levels. The protection circuit senses the junction temperature of the switch and shuts it off. Hysteresis is built into the thermal sense circuit, and after the device has cooled approximately 20 degrees, the switch turns back on. The switch continues to cycle in this manner until the load fault or input power is removed.

The TPS2044 and TPS2054 implement a dual thermal trip to allow fully independent operation of the power distribution switches. In an overcurrent or short-circuit condition the junction temperature will rise. Once the die temperature rises to approximately 140°C, the internal thermal sense circuitry checks which power switch is in an overcurrent condition and turns that power switch off, thus isolating the fault without interrupting operation of the adjacent power switch. Should the die temperature exceed the first thermal trip point of 140°C and reach 160°C, both switches turn off. The \overline{OC} open-drain output is asserted (active low) when overtemperature or overcurrent occurs.

undervoltage lock-out (UVLO)

An undervoltage lockout ensures that the power switch is in the off state at power up. Whenever the input voltage falls below approximately 2 V, the power switch will be quickly turned off. This facilitates the design of hot-insertion systems where it is not possible to turn off the power switch before input power is removed. The UVLO will also keep the switch from being turned on until the power supply has reached at least 2 V, even if the switch is enabled. Upon reinsertion, the power switch will be turned on with a controlled rise time to reduce EMI and voltage overshoots.

Universal Serial Bus (USB) applications

The Universal Serial Bus (USB) interface is a 12-Mb/s, or 1.5-Mb/s, multiplexed serial bus designed for low-to-medium bandwidth PC peripherals (e.g., keyboards, printers, scanners, and mice). The four-wire USB interface is conceived for dynamic attach-detach (hot plug-unplug) of peripherals. Two lines are provided for differential data, and two lines are provided for 5-V power distribution.

USB data is a 3.3-V level signal, but power is distributed at 5 V to allow for voltage drops in cases where power is distributed through more than one hub across long cables. Each function must provide its own regulated 3.3 V from the 5-V input or its own internal power supply.

The USB specification defines the following five classes of devices, each differentiated by power-consumption requirements:

- Hosts/self-powered hubs (SPH)
- Bus-powered hubs (BPH)
- Low-power, bus-powered functions
- High-power, bus-powered functions
- Self-powered functions

Self-powered and bus-powered hubs distribute data and power to downstream functions. The TPS2044 and TPS2054 can provide power-distribution solutions for many of these classes of devices.

TPS2044, TPS2054 QUAD POWER-DISTRIBUTION SWITCHES

SLVS174A – JULY 1998 – REVISED OCTOBER 1998

APPLICATION INFORMATION

host/self-powered and bus-powered hubs

Hosts and self-powered hubs have a local power supply that powers the embedded functions and the downstream ports (see Figure 37). This power supply must provide from 5.25 V to 4.75 V to the board side of the downstream connection under full-load and no-load conditions. Hosts and SPHs must have current limit protection and must report overcurrent conditions to the USB controller. Typical SPHs are desktop PCs, monitors, printers, and stand-alone hubs.

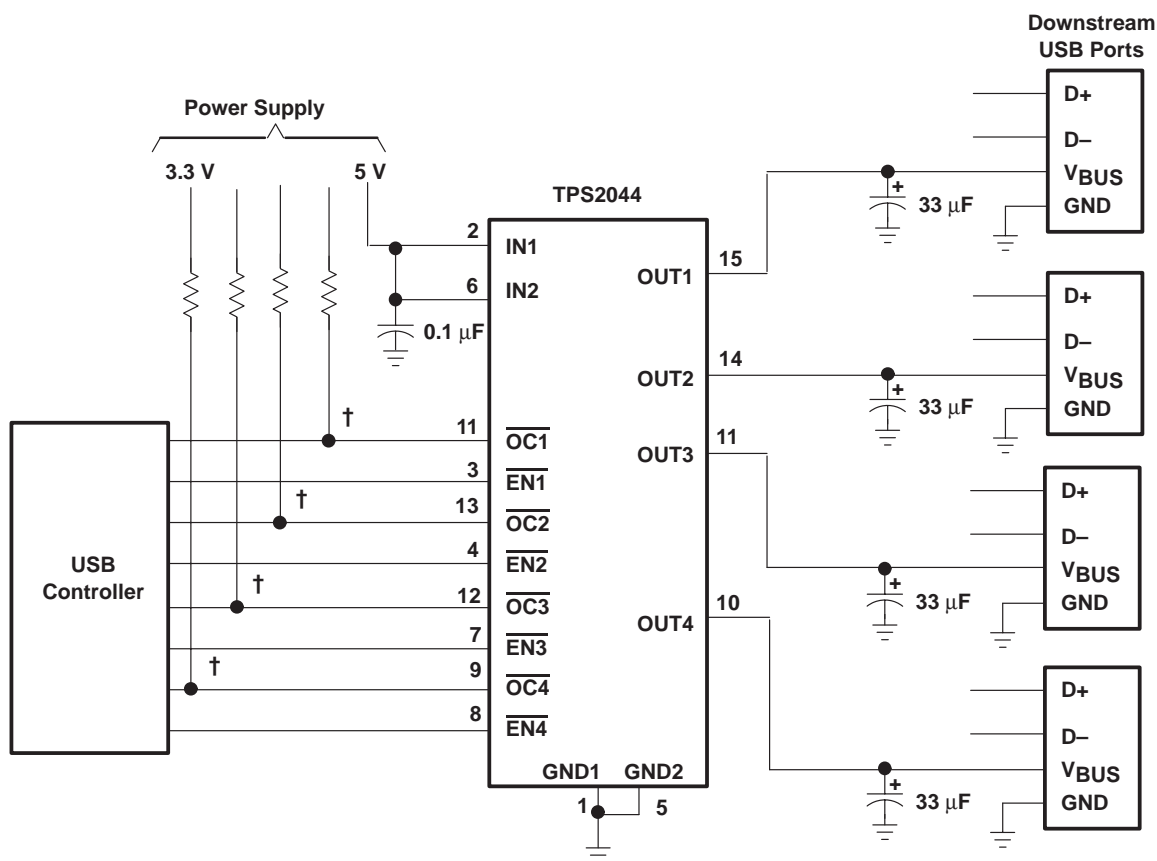

† An RC filter may be needed, see Figure 36

Figure 37. Typical Four-Port USB Host/Self-Powered Hub

Bus-powered hubs obtain all power from upstream ports and often contain an embedded function. The hubs are required to power up with less than one unit load. The BPH usually has one embedded function, and power is always available to the controller of the hub. If the embedded function and hub require more than 100 mA on power up, the power to the embedded function may need to be kept off until enumeration is completed. This can be accomplished by removing power or by shutting off the clock to the embedded function. Power switching the embedded function is not necessary if the aggregate power draw for the function and controller is less than one unit load. The total current drawn by the bus-powered device is the sum of the current to the controller, the embedded function, and the downstream ports, and it is limited to 500 mA from an upstream port.

APPLICATION INFORMATION

low-power bus-powered functions and high-power bus-powered functions

Both low-power and high-power bus-powered functions obtain all power from upstream ports; low-power functions always draw less than 100 mA, and high-power functions must draw less than 100 mA at power up and can draw up to 500 mA after enumeration. If the load of the function is more than the parallel combination of 44 Ω and 10 μF at power up, the device must implement inrush current limiting (see Figure 38).

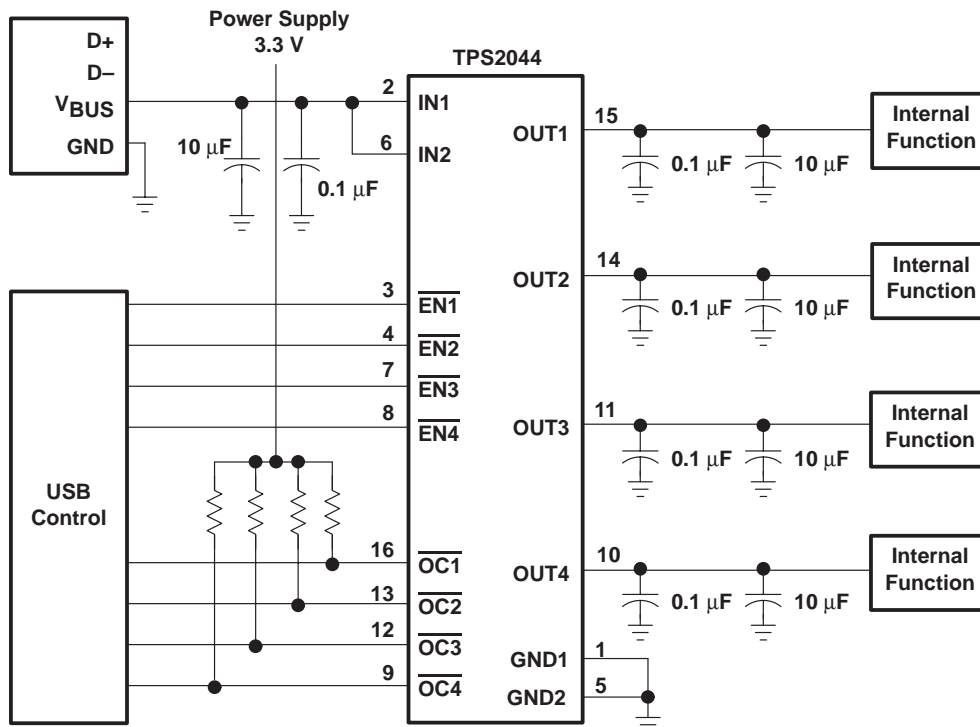

Figure 38. High-Power Bus-Powered Function

TPS2044, TPS2054

QUAD POWER-DISTRIBUTION SWITCHES

SLVS174A – JULY 1998 – REVISED OCTOBER 1998

USB power-distribution requirements

USB can be implemented in several ways, and, regardless of the type of USB device being developed, several power distribution features must be implemented.

- Hosts/Self-Powered Hubs must:
 - Current-limit downstream ports
 - Report overcurrent conditions on USB V_{BUS}
- Bus-Powered Hubs must:
 - Enable/disable power to downstream ports
 - Power up at <100 mA
 - Limit inrush current (<44 Ω and 10 μF)
- Functions must:
 - Limit inrush currents
 - Power up at <100 mA

The feature set of the TPS2044 and TPS2054 allows them to meet each of these requirements. The integrated current-limiting and overcurrent reporting is required by hosts and self-powered hubs. The logic-level enable and controlled rise times meet the need of both input and output ports on bus-power hubs, as well as the input ports for bus-power functions (see Figure 39).



POST OFFICE BOX 655303 • DALLAS, TEXAS 75265

APPLICATION INFORMATION

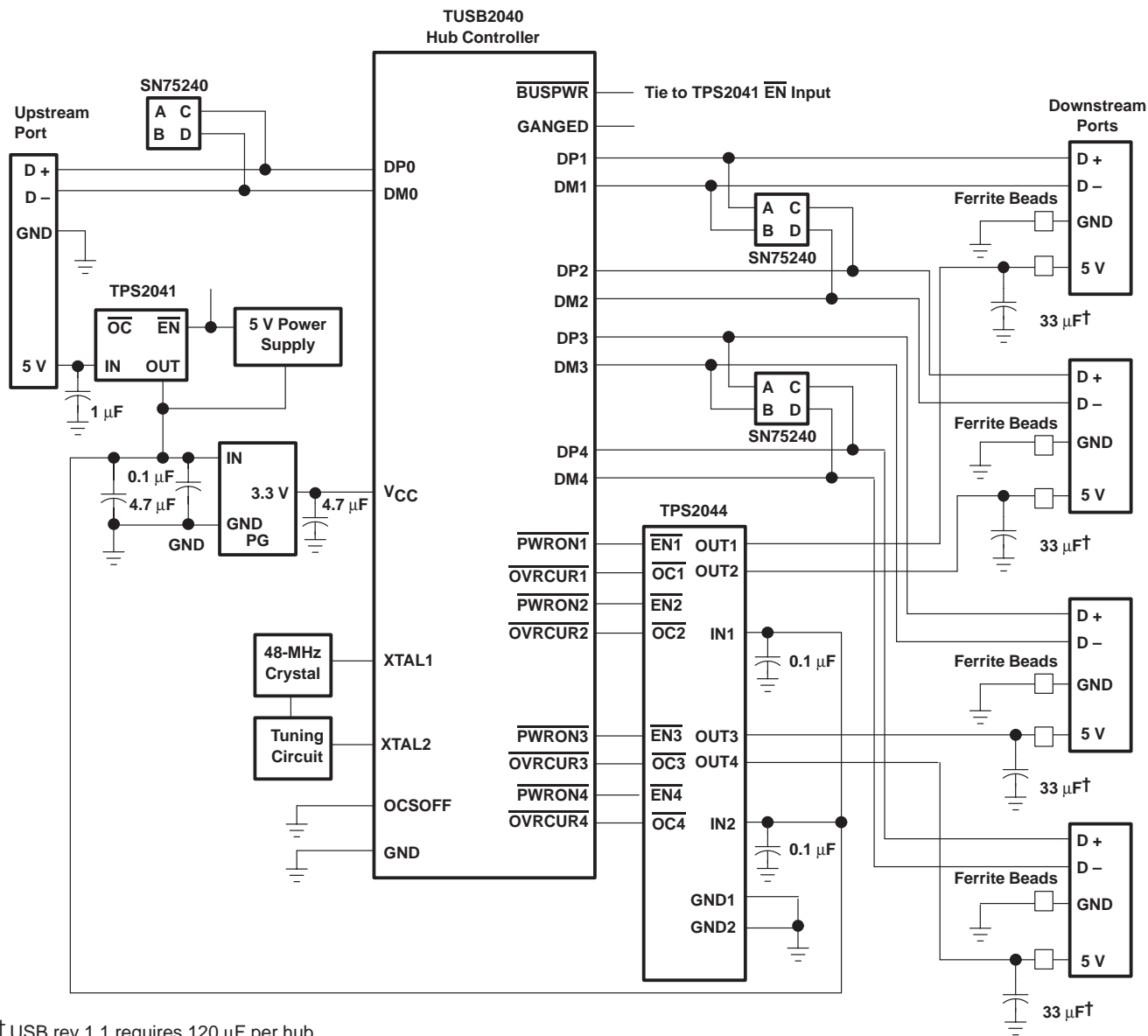

† USB rev 1.1 requires 120 µF per hub.

Figure 39. Hybrid Self/Bus-Powered Hub Implementation

TPS2044, TPS2054 QUAD POWER-DISTRIBUTION SWITCHES

SLVS174A – JULY 1998 – REVISED OCTOBER 1998

APPLICATION INFORMATION

generic hot-plug applications (see Figure 40)

In many applications it may be necessary to remove modules or pc boards while the main unit is still operating. These are considered hot-plug applications. Such implementations require the control of current surges seen by the main power supply and the card being inserted. The most effective way to control these surges is to limit and slowly ramp the current and voltage being applied to the card, similar to the way in which a power supply normally turns on. Due to the controlled rise times and fall times of the TPS2044 and TPS2054, these devices can be used to provide a softer start-up to devices being hot-plugged into a powered system. The UVLO feature of the TPS2044 and TPS2054 also ensures the switch will be off after the card has been removed, and the switch will be off during the next insertion. The UVLO feature guarantees a soft start with a controlled rise time for every insertion of the card or module.

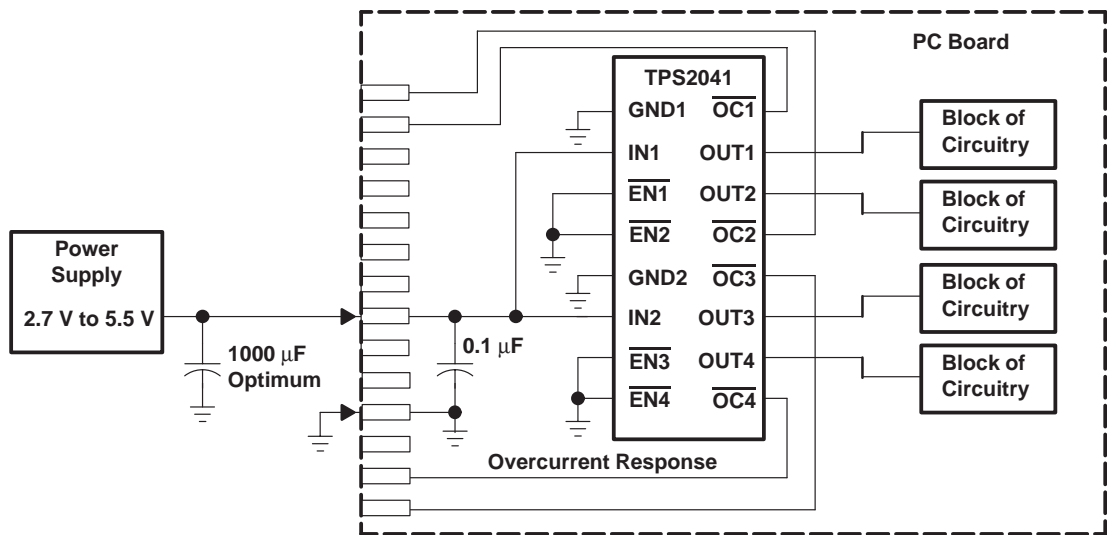

Figure 40. Typical Hot-Plug Implementation

By placing the TPS2044 and TPS2054 between the V_{CC} input and the rest of the circuitry, the input power will reach these devices first after insertion. The typical rise time of the switch is approximately 2.5 ms, providing a slow voltage ramp at the output of the device. This implementation controls system surge currents and provides a hot-plugging mechanism for any device.

MECHANICAL DATA

D (R-PDSO-G**)

PLASTIC SMALL-OUTLINE PACKAGE

14 PIN SHOWN

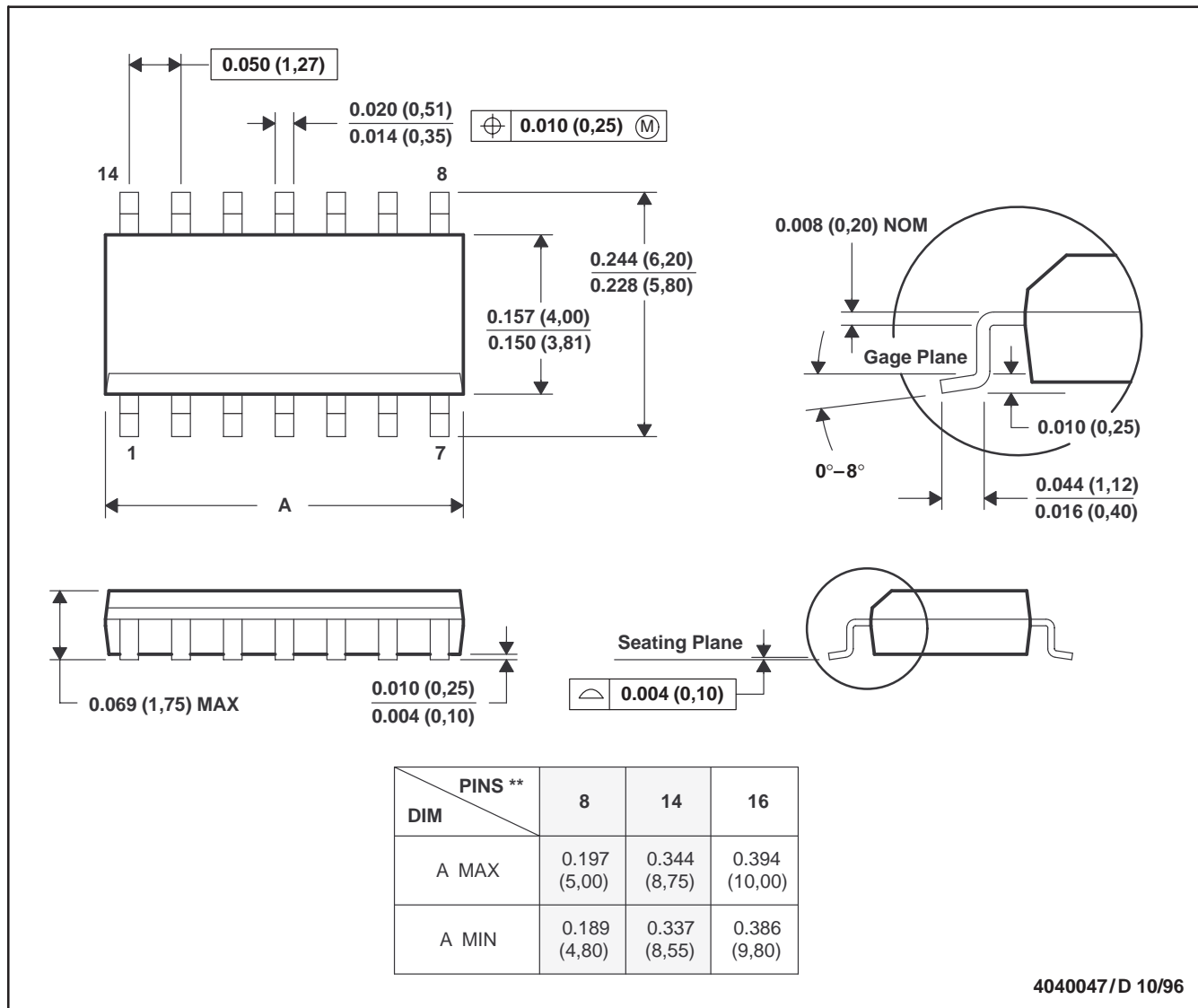

- NOTES: A. All linear dimensions are in inches (millimeters).
 B. This drawing is subject to change without notice.
 C. Body dimensions do not include mold flash or protrusion, not to exceed 0.006 (0,15).
 D. Falls within JEDEC MS-012

IMPORTANT NOTICE

Texas Instruments and its subsidiaries (TI) reserve the right to make changes to their products or to discontinue any product or service without notice, and advise customers to obtain the latest version of relevant information to verify, before placing orders, that information being relied on is current and complete. All products are sold subject to the terms and conditions of sale supplied at the time of order acknowledgement, including those pertaining to warranty, patent infringement, and limitation of liability.

TI warrants performance of its semiconductor products to the specifications applicable at the time of sale in accordance with TI's standard warranty. Testing and other quality control techniques are utilized to the extent TI deems necessary to support this warranty. Specific testing of all parameters of each device is not necessarily performed, except those mandated by government requirements.

CERTAIN APPLICATIONS USING SEMICONDUCTOR PRODUCTS MAY INVOLVE POTENTIAL RISKS OF DEATH, PERSONAL INJURY, OR SEVERE PROPERTY OR ENVIRONMENTAL DAMAGE ("CRITICAL APPLICATIONS"). TI SEMICONDUCTOR PRODUCTS ARE NOT DESIGNED, AUTHORIZED, OR WARRANTED TO BE SUITABLE FOR USE IN LIFE-SUPPORT DEVICES OR SYSTEMS OR OTHER CRITICAL APPLICATIONS. INCLUSION OF TI PRODUCTS IN SUCH APPLICATIONS IS UNDERSTOOD TO BE FULLY AT THE CUSTOMER'S RISK.

In order to minimize risks associated with the customer's applications, adequate design and operating safeguards must be provided by the customer to minimize inherent or procedural hazards.

TI assumes no liability for applications assistance or customer product design. TI does not warrant or represent that any license, either express or implied, is granted under any patent right, copyright, mask work right, or other intellectual property right of TI covering or relating to any combination, machine, or process in which such semiconductor products or services might be or are used. TI's publication of information regarding any third party's products or services does not constitute TI's approval, warranty or endorsement thereof.