

System Design Considerations Using the TRF1400 RF Telemetry Receiver

Application Report

SLWA005D
APRIL 1998



Printed on Recycled Paper

IMPORTANT NOTICE

Texas Instruments (TI) reserves the right to make changes to its products or to discontinue any semiconductor product or service without notice, and advises its customers to obtain the latest version of relevant information to verify, before placing orders, that the information being relied on is current.

TI warrants performance of its semiconductor products and related software to the specifications applicable at the time of sale in accordance with TI's standard warranty. Testing and other quality control techniques are utilized to the extent TI deems necessary to support this warranty. Specific testing of all parameters of each device is not necessarily performed, except those mandated by government requirements.

Certain applications using semiconductor products may involve potential risks of death, personal injury, or severe property or environmental damage ("Critical Applications").

TI SEMICONDUCTOR PRODUCTS ARE NOT DESIGNED, INTENDED, AUTHORIZED, OR WARRANTED TO BE SUITABLE FOR USE IN LIFE-SUPPORT APPLICATIONS, DEVICES OR SYSTEMS OR OTHER CRITICAL APPLICATIONS.

Inclusion of TI products in such applications is understood to be fully at the risk of the customer. Use of TI products in such applications requires the written approval of an appropriate TI officer. Questions concerning potential risk applications should be directed to TI through a local SC sales office.

In order to minimize risks associated with the customer's applications, adequate design and operating safeguards should be provided by the customer to minimize inherent or procedural hazards.

TI assumes no liability for applications assistance, customer product design, software performance, or infringement of patents or services described herein. Nor does TI warrant or represent that any license, either express or implied, is granted under any patent right, copyright, mask work right, or other intellectual property right of TI covering or relating to any combination, machine, or process in which such semiconductor products or services might be or are used.

Contents

Abstract	1
1 Introduction	1
2 Design Considerations	2
2.1 External Components	2
2.2 Antenna Issues	2
2.3 Proximity to Local Noise Sources	3
2.4 Sensitivity/Out-of-Band Rejection	3
3 Bit Error Rate Versus Sensitivity	5
3.1 Symbol Code Format	5
3.2 Determining Symbol Identity	5
3.3 Testing RF Telemetry Receivers for BER	7
3.4 Test Methodology	8
3.5 Calculating BER	8
3.6 Test Results	9
3.7 BER Versus Sensitivity Test Frequencies	10
4 Application Example	11

List of Figures

1 TRF1400 Average Sensitivity and Out-of-Band Rejection	4
2 Symbol Code Format	5
3 Bit Identity Determination	6
4 BER Test Set-Up	7
5 Data and Resulting ASK Signal	8
6 TRF1400 BER Versus Sensitivity at 315 MHz With a 3 Kbps Data Rate	9
7 TRF1400 Demonstration Circuit for 315-MHz Operation	11
8 TRF1400 Demo Circuit Board Layout — Top Side	12
9 TRF1400 Demo Circuit Board Layout — Bottom Side	12
10 TRF1400 Demo Circuit Board Solder Mask — Top Side	12
11 TRF1400 Demo Circuit Board Solder Mask — Bottom Side	13
12 TRF1400 Demo Circuit Board Silk Screen	13

List of Tables

1 TRF1400 315-MHz Demonstration Circuit Parts List	14
--	----

(This page has been left blank intentionally.)

System Design Considerations Using the TRF1400 RF Telemetry Receiver

ABSTRACT

TI's RF telemetry receiver is a fully-integrated VHF/UHF receiver on a chip. The selection of the external components and the layout of the circuit board required to complete the circuits are critical to achieving maximum performance. This application report discusses these issues and provides demonstration circuit schematics, demo board layouts, a source for Gerber plots, and a complete parts list for demo boards that are proven performers.

1 Introduction

The Texas Instruments (TI™) TRF1400 VHF/UHF RZ ASK RF telemetry receiver is specifically designed for RZ ASK (return-to-zero amplitude-shift keyed) communications systems operating in the 200 MHz – 450 MHz band. These remote control receivers are integrated VHF/UHF receivers on a chip, with only a small number of external components needed to create fully functional receiver circuits. The interface to the working environment, however, requires some attention to the board layout and external components to take full advantage of the device capabilities. System design issues such as antenna design and proximity of local noise sources should also be considered. And finally, receiver sensitivity must be balanced against BERs (bit error rates) for optimum performance in a system.

Application examples include schematics, board layouts, and a detailed parts list for demo boards. These are the same circuits, boards, and parts that were used as test circuits and test boards during the development of the devices.

See the data sheet for the TRF1400 (TI literature number SLWS014) for detailed information on the device.

2 Design Considerations

2.1 External Components

As with any RF design, the successful integration of a TRF1400 receiver device into a circuit board is dependent on the layout of the board and the quality of the external components used. Component tolerance and Q specifications (where applicable) should be observed during the selection of the external parts. This document includes layout artwork for the demo circuit board and a complete list of required external parts (with tolerances) for device performance at 315 MHz. A complete set of Gerber photoplotter files can be obtained by contacting any TI Field Sales Office.

2.2 Antenna Issues

The coupling of the signal into the TRF1400 device is of paramount importance if the maximum system sensitivity is to be attained. The input network provided in the evaluation circuit is designed to match the receiver input to a nominal 50- Ω load. A trap to reduce interference from 105-MHz broadcast signals is also included in this network.

The antenna that is used with this receiver should not only be matched to the TRF1400 input impedance, but should also be of an efficient design. A quarter-wave monopole, for example, is a good choice. Loop antennas may also be used, but their performance may vary widely given the available area and proximity to the circuit board. Loop antennas, even those shorter than one wavelength, tend to exhibit distinct nulls in the antenna response pattern as well. If possible, the antenna should be mounted away from the receiver circuit board. Unfortunately, in many instances system requirements do not allow this, and they impose conflicting requirements of space, ease of input matching, and efficiency.

If requirements dictate that the antenna be included in a receiver module or other space-restricted area, an antenna that is close to an ideal form should be selected and then examined to determine how it might be integrated into the available space. If this is not possible or not possible without folding the element over the circuit board, the antenna should be swept with a network analyzer to determine the effects of the proximity to the ground plane and other devices. Where possible, the antenna should be trimmed to achieve matching or to approach a region on the Smith Chart[®] where a 1-element match to 50 Ω may be achieved. A folded antenna should be kept at least 0.5 inch from the ground plane to avoid excessive sensitivity to mechanical vibration. The design of such an integrated antenna may be empirical, as is often the case in nonideal situations.

Smith Chart is a registered trademark of the Analog Instruments Company.

2.3 Proximity to Local Noise Sources

Any receiver should be shielded from noise sources that can interfere with the reception of the intended signal. Care should be taken when integrating the TRF1400 device onto a board with microprocessors or other high-speed logic elements. Due to their high harmonic content, digital signals produce broadband noise of sufficient power to interfere with receiver operation both through the front end and by coupling to board traces. Where possible, digital lines should be routed around and away from the receiver, and on multilayer boards, running separate planes for these signals should be considered. Power supply lines should be regulated and filtered, with particular attention to filtering the supply lines again at the device power terminals to ensure clean lines. Both low-frequency and high-frequency filter sections are required.

Care should also be taken to suppress transient noise from relays or broadband noise from motors and other sources.

2.4 Sensitivity/Out-of-Band Rejection

Out-of-band rejection (rejection of signals outside the intended passband of the receiver) depends to a large extent on the SAW (surface acoustic wave) filter used in the design of the complete receiver circuit. In the board layout depicted for the TRF1400, the pad for the SAW filter has been carefully designed to maximize the isolation between the input and output pins by including a ground *island* with low impedance paths (vias) between the top and bottom ground planes. Figure 1 shows the average sensitivity and out-of-band rejection of the circuit when using the RFM RF1211 SAW specified for the TRF1400 demo board.

Plated-through holes should not be used on the input and output pins of the SAW filter. Plated-through holes *should* be used for all the ground vias, however, particularly in the island area.

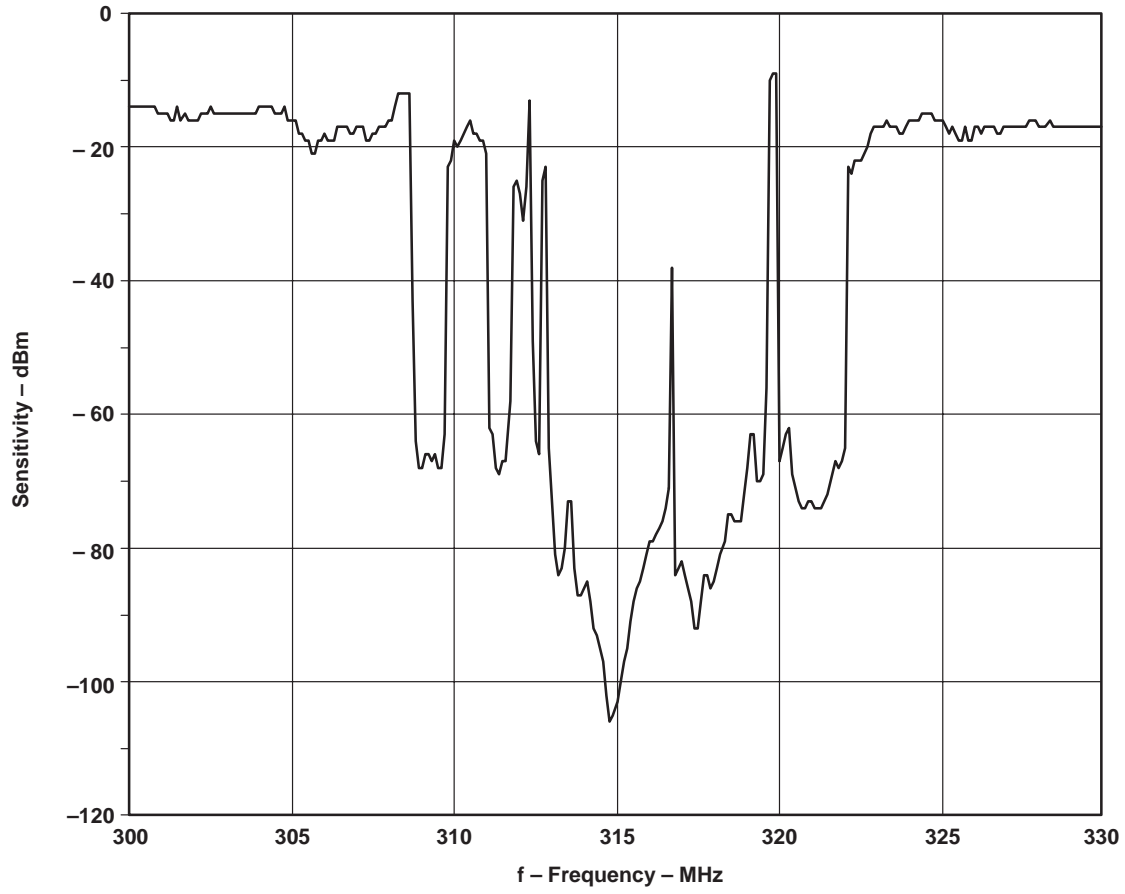

Figure 1. TRF1400 Average Sensitivity and Out-of-Band Rejection

3 Bit Error Rate Versus Sensitivity

RF telemetry (and other) receiver sensitivity specifications are relative to the BER (bit error rate) of the system. Everything else remaining equal, the higher the sensitivity of the receiver, the greater the incidence of errors. The BER of a system is the ratio of incorrectly received bits to the transmitted bits, or errors divided by the total number of bits. The ideal system would have very high sensitivity and a very low BER.

3.1 Symbol Code Format

Each bit of a typical symbol code format is represented by a 3-bit symbol for transmission. The 0 symbol consists of the bit sequence 100, and the 1 symbol consists of the bit sequence 110, as shown in Figure 2.

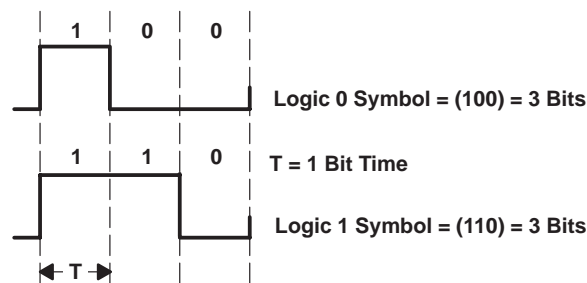

Figure 2. Symbol Code Format

The 1 symbol and the 0 symbol both have the same first bit (1) and the same last bit (0). Only the middle bit varies between 1 and 0 to indicate that the symbol is a 1 symbol or a 0 symbol. Using these particular bit sequences to represent a 1 symbol or a 0 symbol results in increased noise immunity and receive-function robustness over schemes that do not use symbols or that use symbols with other bit sequences.

3.2 Determining Symbol Identity

The BER of the overall system is largely dependent on the ability of the decoder to correctly determine the identity of each received symbol. An RF receiver device receives, detects, and processes an incoming data transmission into a baseband data stream of 3-bit symbols, which is then applied to the decoder. The decoder must first determine the identity of each received symbol and convert it into a 1 or a 0 as appropriate to recover the original code.

To help ensure that each symbol is decoded into a 1 or 0 data bit correctly, a special decoding procedure is used. In this procedure, the identity of each of the three bits in a symbol is determined separately and then the identity of the complete symbol is concluded from those results. First, to identify the three bits in a symbol, each bit is sampled multiple times (approximately 100 times) during a period that is one-half of a bit time. The decoder schedules this sampling to occur in the middle of the bit time so that there is 25% of the bit time before the sampling begins and 25% of the bit time after it ends (see Figure 3).

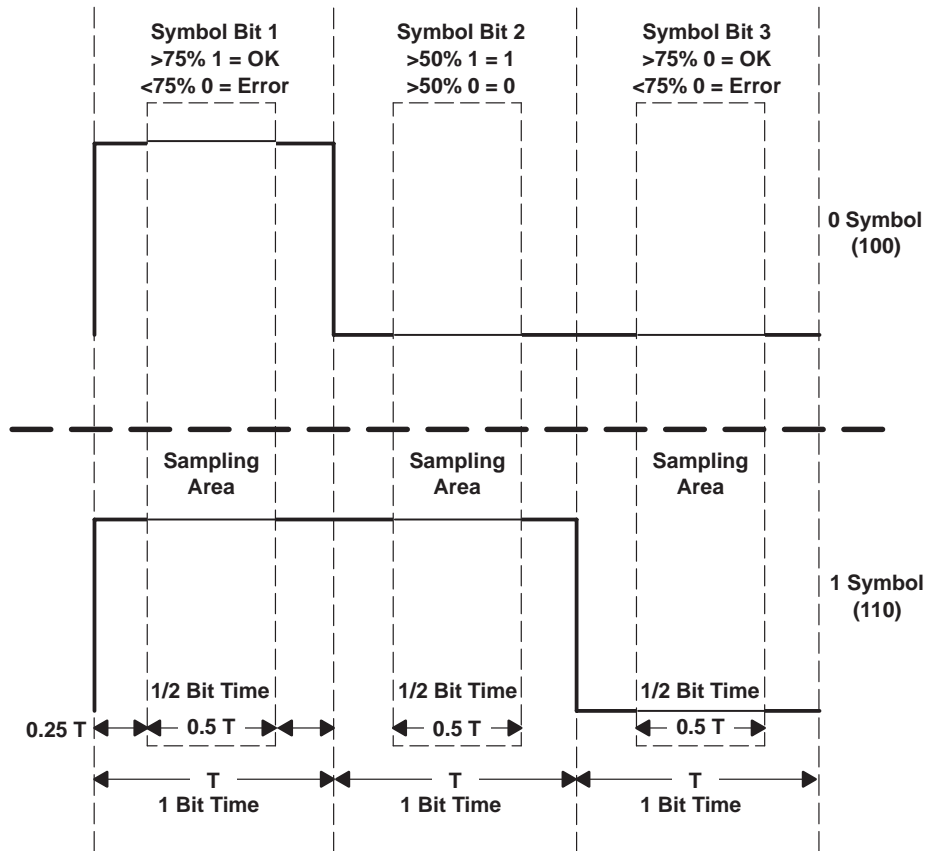

Figure 3. Bit Identity Determination

The identity of each bit is then determined separately by the decoder using the following criteria. For the first bit in the symbol to be considered correct, it must be high for at least 75% of the sample period. For the last bit in the symbol to be considered correct, it must be low for at least 75% of the sample period. Otherwise, there is a format error. The middle bit carries the identity of the symbol and can be either high or low. To be considered a 1 bit, the middle bit must be high at least 50% of its sample period. To be considered a 0 bit, the middle bit must be low at least 50% of its sample period. Based on this analysis, the decoder determines the identity of each symbol.

During testing, if the criterion for either the first or last bit in the symbol is not met, a format error is reported. If the middle bit is high less than 50% of the sample period for a 1 symbol or if is low less than 50% of the sample period for a 0 symbol, a code error is reported. A symbol is considered to be received correctly only if all three bits are determined to be correct.

3.3 Testing RF Telemetry Receivers for BER

Determining the BER of a TI RF telemetry receiver-equipped system is relatively straightforward. Collect the equipment and connect it together as shown in Figure 4. The BER Tester is a microcontroller-based device designed specifically for testing and determining BER.

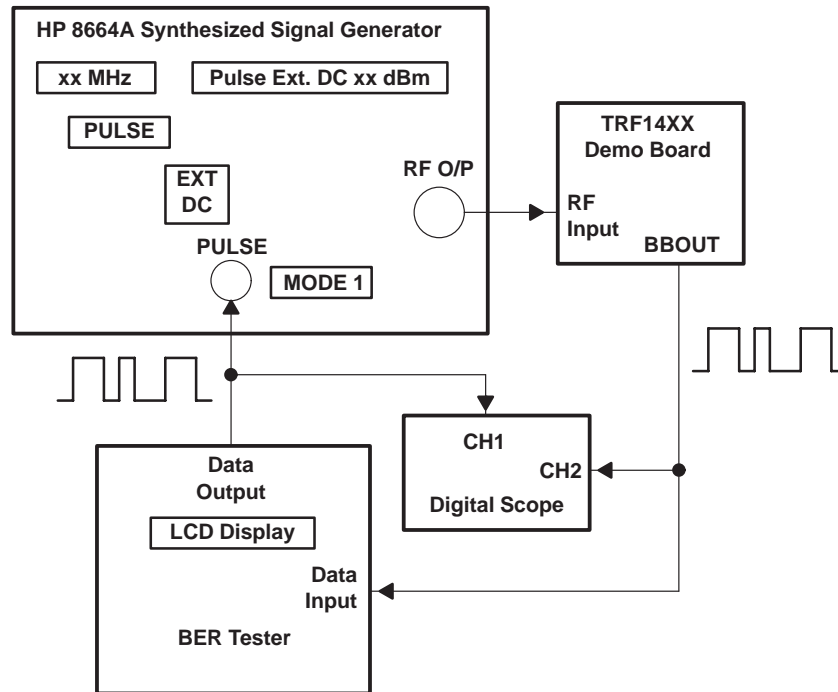

Figure 4. BER Test Set-Up

The signal generator provides the carrier wave and is adjusted to the frequency of the receiver. The Data Output of the BER Tester is connected to the external modulation input of the signal generator. The signal generator is then set to produce 100% on/off-keyed (or ASK) modulation of the carrier by the data signal supplied from the BER Tester as shown in Figure 5. The ASK modulated signal from the signal generator is applied to the TRF14XX Demo Board RF input through a cable and the signal generator output attenuator set for the desired signal strength. The baseband data output (BBOUT) of the demo board is connected back to the Data Input port on the BER Tester. A digital scope can be used to examine the data input to the receiver system versus the data output from it.

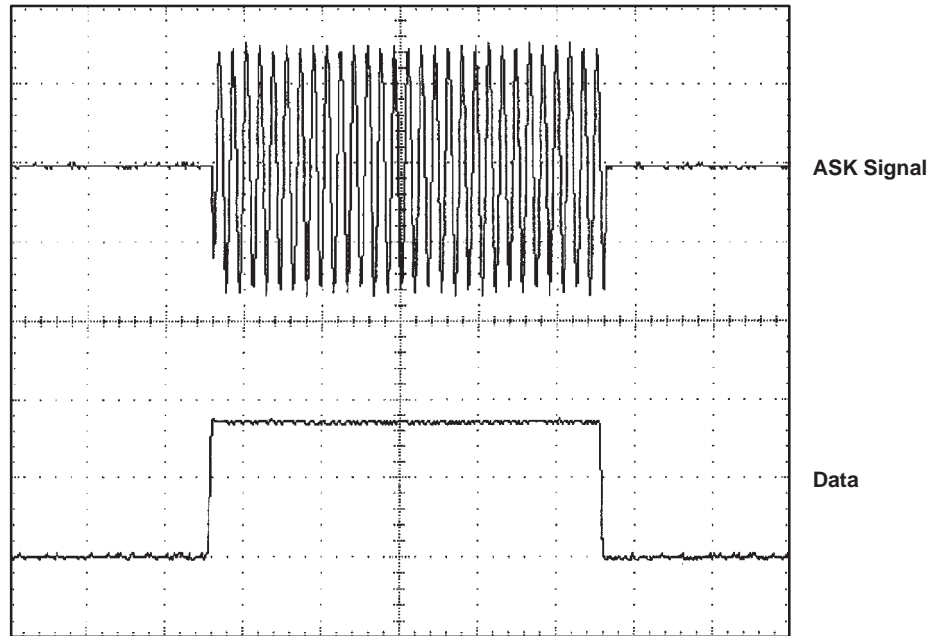

Figure 5. Data and Resulting ASK Signal

3.4 Test Methodology

Using the test setup as described, the BER Tester transmitted more than 1 million code symbols at a rate of 1000 symbols per second. The BER Tester compared the received data from the demo board with the code symbols it had sent and displayed the error on the LCD.

To confirm that the BER Tester would detect errors, the Data Output line from the BER tester was disconnected from the modulation input of the signal generator. The BER Tester was then expected to report the resulting 100% BER. The BER Tester, however, indicated 99.5% BER.

3.5 Calculating BER

Because of the discrepancy between the 100% actual BER in the test and the 99.5% BER that the tester reported, an offset factor needs to be added to the formula for calculating BER when using *this* BER Tester.

Use formula 1 to calculate actual BER from data obtained from the BER Tester.

$$BER = (Total\ Bit\ Error \times 1.005) \div 1048576 \tag{1}$$

Where:

Total Bit Error = format error + code error (see Figure 3)

1.005 = 0.5% BER offset factor

1048576 = Total number of code symbols sent by BER Tester

The 0.5% BER offset factor is from the particular BER Tester that was used for that test. Different BER Testers are likely to have slightly different offsets. The offset of a BER Tester should be determined and used to derive the offset factor to be used in any calculations.

3.6 Test Results

BER versus average sensitivity test results are shown in the graphs that follow. Figure 6 is a plot for a TI TRF1400 receiver IC from lot #61ALN2T installed in a #8 demo board tuned for 314.8 MHz. Graph (a) is the overall view and graph (b) is the expanded-scale detail.

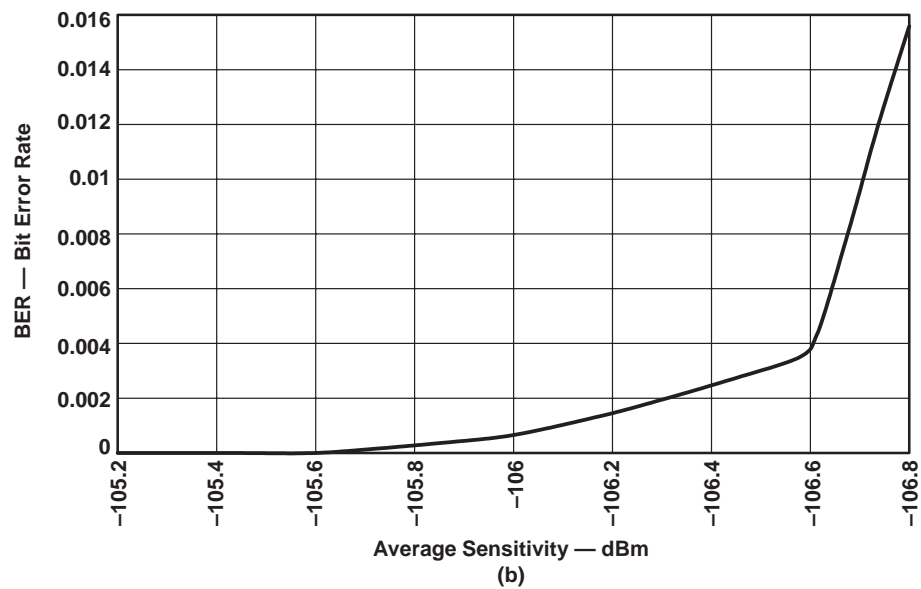
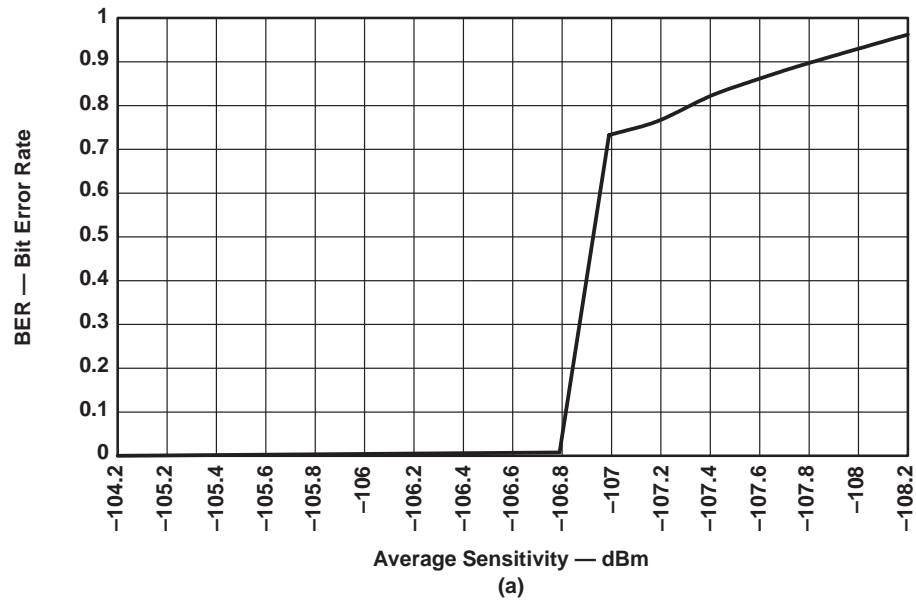

Figure 6. TRF1400 BER Versus Sensitivity at 315 MHz With a 3 Kbps Data Rate

3.7 BER Versus Sensitivity Test Frequencies

The center frequency and the passband characteristics of the SAW filter determine the passband and the sensitivity of the receiver system. The passband response of the SAW device is not flat, but instead, exhibits some ripples. For the purposes of BER/sensitivity testing, the receiver system was first swept to locate the exact frequency of the highest sensitivity. It was then found that the center frequency of the SAW filter (315 MHz) did not coincide with the frequency of highest sensitivity. The frequency showing the greatest sensitivity turned out to be 314.8 MHz for the TRF1400.

4 Application Example

The TRF1400 is a tuned RF amplifier design, using no local oscillator, which avoids the difficulties normally associated with local oscillators. As with any RF design, the successful integration of the device into a circuit board relies heavily on the layout of the board and the quality of the external components. Figure 7 shows the schematic for the TRF1400 demonstration circuit and Figures 8 through 12 show the layout of the demo board. Table 1 lists the parts required to complete the circuit, which demonstrates TRF1400 performance at 315 MHz. Specified component values and tolerances should be observed during the selection of parts.

A complete set of Gerber photoplotter files for the circuit board can be obtained from any TI Field Sales Office.

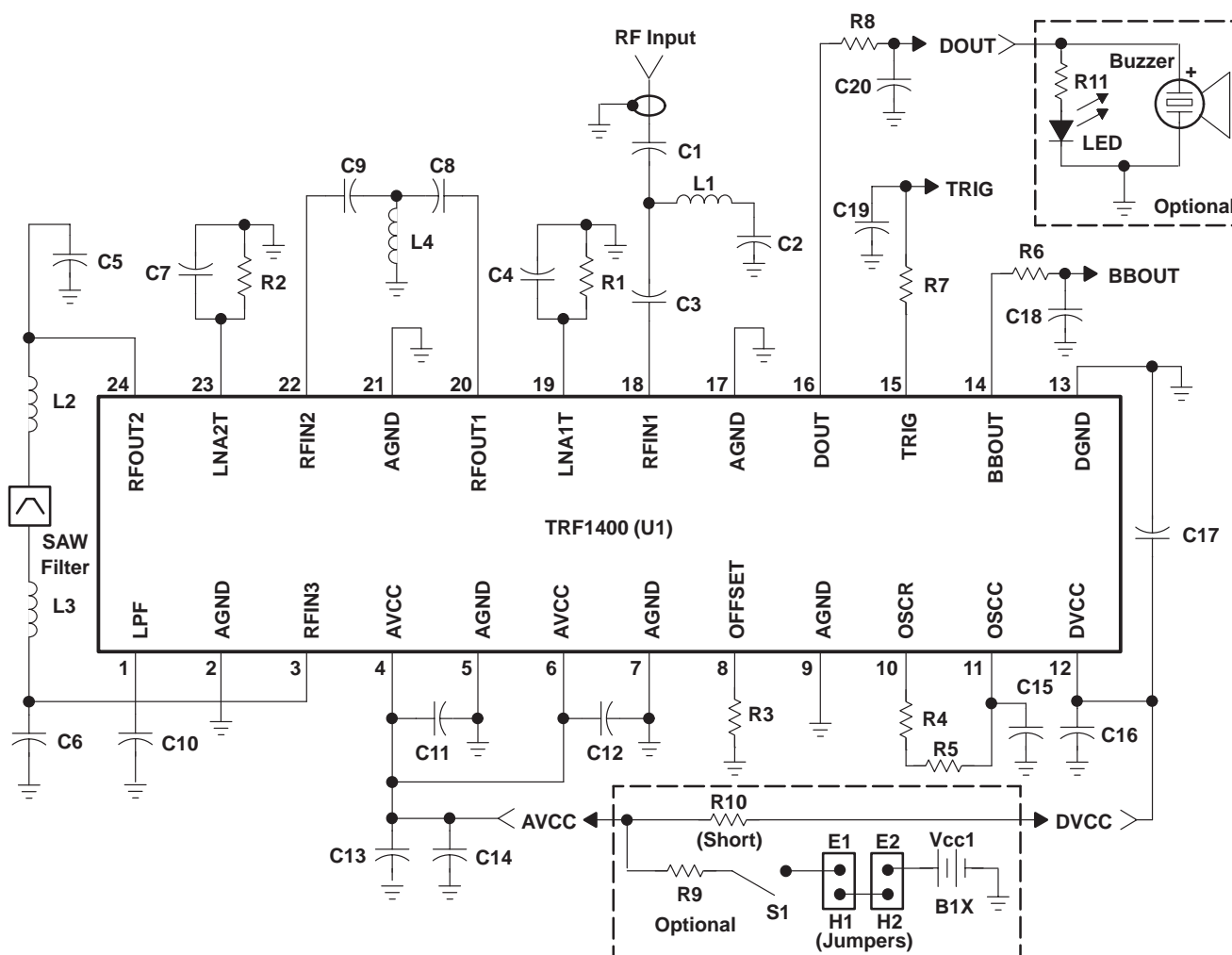
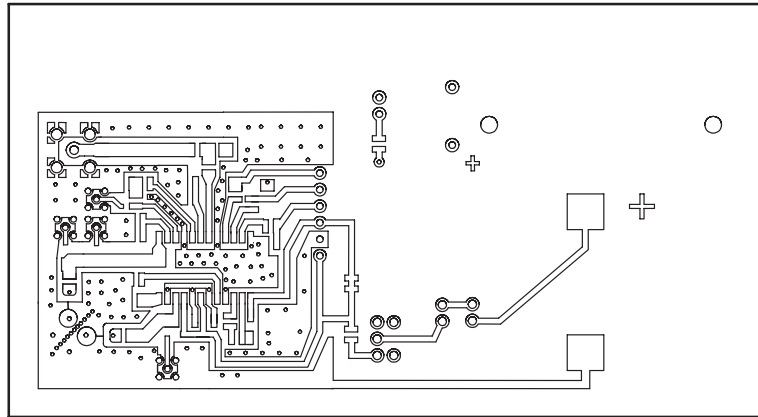

Figure 7. TRF1400 Demonstration Circuit for 315-MHz Operation



NOTE A: Circuit board material is 62 mil G-10 with 1-oz copper, dielectric constant = 4.5

Figure 8. TRF1400 Demo Circuit Board Layout — Top Side

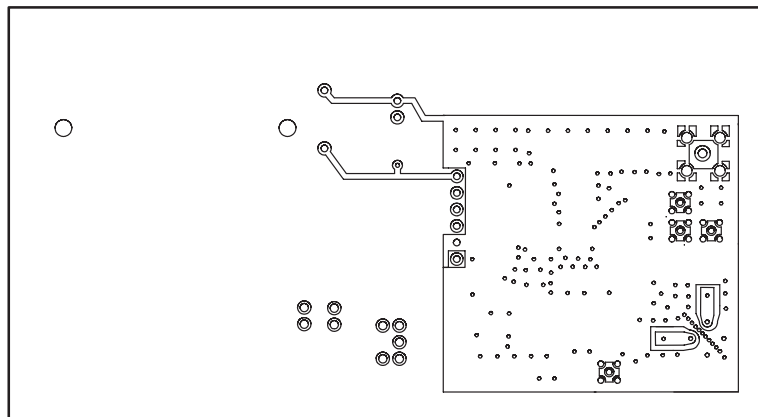

Figure 9. TRF1400 Demo Circuit Board Layout — Bottom Side

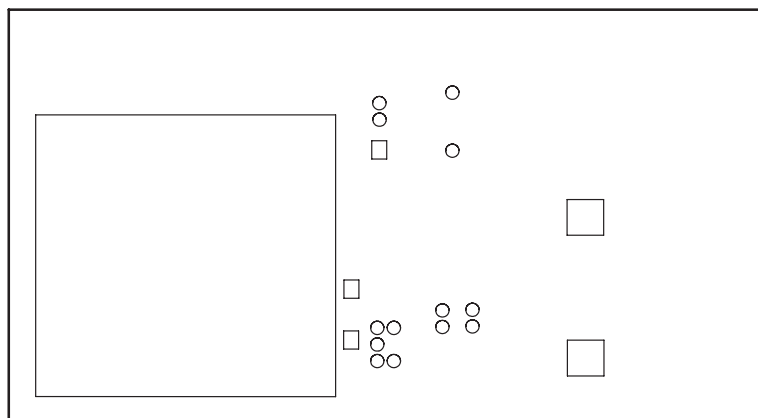

Figure 10. TRF1400 Demo Circuit Board Solder Mask — Top Side

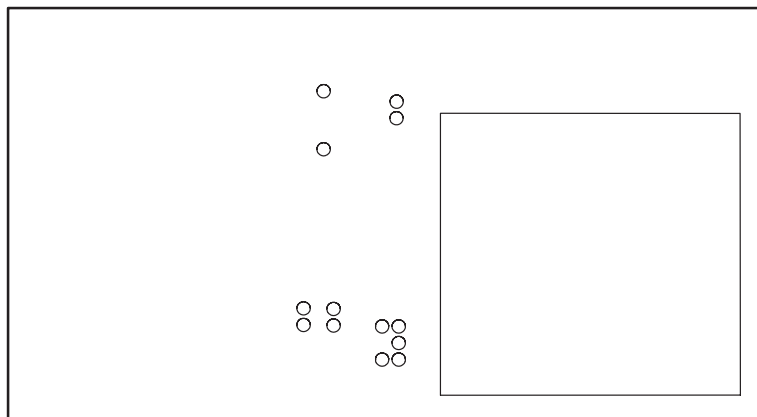

Figure 11. TRF1400 Demo Circuit Board Solder Mask — Bottom Side

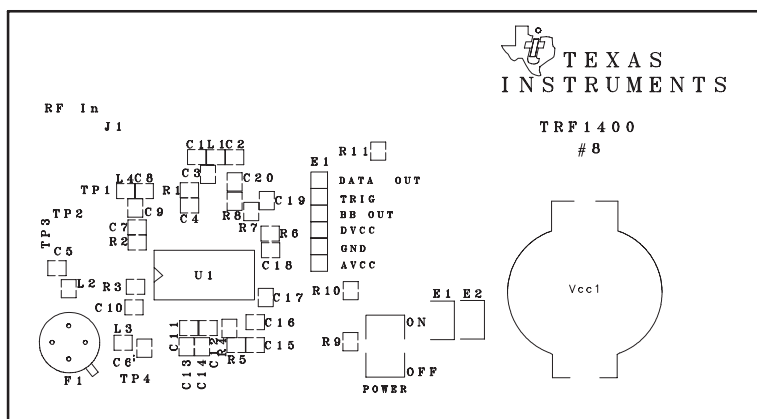

Figure 12. TRF1400 Demo Circuit Board Silk Screen

Table 1. TRF1400 315-MHz Demonstration Circuit Parts List

DESIGNATORS	DESCRIPTION	VALUE	MANUFACTURER	MANUFACTURER P/N
C1	Capacitor	4 pF	Murata	GRM40C0G040C050V
C2, C3	Capacitor	22 pF	Murata	GRM40C0G220J050BD
C4, C7	Capacitor	100 pF	Murata	GRM40C0G101J050BD
C5	Capacitor	5 pF	Murata	GRM40C0G050D050BD
C6	Capacitor	1.5 pF	Murata	GRM40C0G1R5C050BD
C8	Capacitor	3 pF	Murata	GRM40C0G030C050BD
C9	Capacitor	18 pF	Murata	GRM40C0G180J050BD
C10	Capacitor	0.047 μ F	Murata	GRM40X7R473K050
C11, C12, C17, C19	Capacitor	2200 pF	Murata	GRM40X7R222K050BD
C13, C18, C20	Capacitor	0.022 μ F	Murata	GRM40X7R223K050BL
C14, C16	Capacitor, Tantalum [†]	4.7 μ F @ 6.3 V	Panasonic	ECS-T1AY475R
C15	Capacitor	220 pF, 5%	Murata	GRM40C0G221J050BD
E1	2-Pin Connector		3M	2340-6111-TN
E2	2-Pin Connector		3M	2340-6111-TN
E3	6-Pin Connector		3M	2340-6111-TN
H1, H2	Header Shunts		3M	929952-10
F1	SAW Filter	RFM 1211	RFM	RFM 1211
L1	Inductor	47 nH	Coilcraft	0805HS470TMBC
L2	Inductor	82 nH	Coilcraft	0805HS820TKBC
L3	Inductor	120 nH	Coilcraft	0805HS121TKBC
L4	Inductor	39 nH	Coilcraft	0805HS390TMBC
P1	RF SMA Connector		Johnson	142-0701-201
R1	Resistor	1.2 K Ω		
R2	Resistor	1.2 K Ω		
R3	Resistor	3 M Ω		
R4	Resistor	130 K Ω , 1%		
R5	Resistor	0 Ω		
R6, R8	Resistor	1K Ω		
R7	Resistor	100 Ω		
R9	Resistor	680 Ω		
R10	Resistor	short		
R11	Resistor	330 Ω		
S1	Switch		NKK	G-12AP
Vcc1	Battery Clip		Keystone	1061
B1X	Battery, Lithium	3.3-V Coin Cell (2 ea.)	Panasonic	CR2016
U1	Receiver IC	TRF1400	TI	TRF1400

[†] Tantalum capacitors are rated at 6.3 Vdc minimum.