

TRF1400
RF TELEMETRY RECEIVERS
VHF/UHF RZ ASK REMOTE CONTROL RECEIVER
 SLWS014E – JUNE 1996 – REVISED APRIL 1998

- **Wide VHF/UHF Frequency Range**
200 MHz to 450 MHz for World-Wide Remote Control Frequency Compatibility
- **High Receiver Sensitivity** . . . -103 dBm at 315 MHz
- **Accepts Baseband Data Rates From 500 Hz to 10 kHz**
- **Manchester-Decoded and Raw Baseband Outputs for Easy Interface to Serial Data Decoders and Microcontrollers**
- **TRF (Tuned Radio Frequency) Design Eliminates Local Oscillator (No Emissions) and Reduces Many Government Type Approvals (Including FCC)**
- **Adjustable Internal Sampling Clock Set By External Components**
- **Internal Amplifier and Comparator for Amplification and Shaping of Low-Level Input Signals With Average-Detecting Autobias Adaptive Threshold Circuitry for Improved Sensitivity**
- **Minimum External Component Count and Surface-Mount Packaging for Extremely Small Circuit Footprint – Typically Replaces More Than 40 Components in an Equivalent Discrete Solution**
- **No Manual Alignment When Using SAW Filters**
- **Advanced Submicron BiCMOS Process Technology for Minimum Power Consumption**

description

The TRF1400 VHF/UHF RZ ASK remote control receiver is specifically designed for RZ ASK (return-to-zero amplitude-shift keyed) communications systems operating in the 200-MHz to 450-MHz band. This device is targeted for use in automotive and home security systems, garage door openers, remote utility metering, and other low-power remote control and telemetry systems.

A complete RZ ASK receiver solution on a chip, the TRF1400 requires only a minimum of external components for operation. This significantly reduces the complexity and footprint of new designs compared with current discrete receiver designs. The TRF1400 requires no manual alignment when using external SAW (surface acoustic wave) filters. For a lower-cost solution, the device is also compatible with external LC components.

The TRF1400 also includes several on-chip features that normally require additional circuitry in a receiver system design. These include two low-noise front-end amplifiers, an RF amplifier/comparator for detection and shaping of input signals, and a demodulated RZ ASK baseband TTL-level output that readily interfaces to self-synchronizing devices. Also included is on-chip Manchester decoding logic that provides a specially formatted TTL data output, synchronized with a trigger output, for easy interface to any microcontroller using Manchester-encoded data.

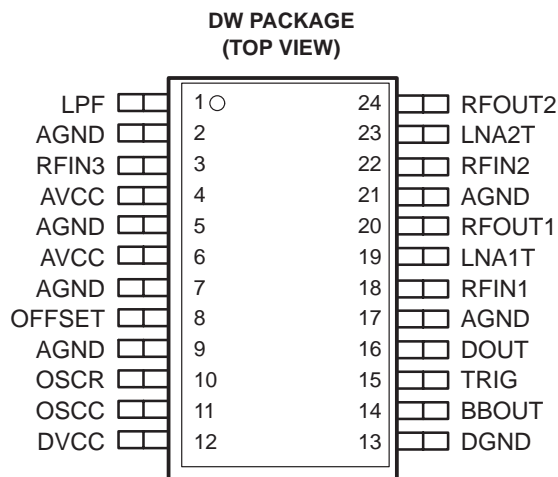

These devices have limited built-in ESD protection. The leads should be shorted together or the device placed in conductive foam during storage or handling to prevent electrostatic damage to the MOS gates.



Please be aware that an important notice concerning availability, standard warranty, and use in critical applications of Texas Instruments semiconductor products and disclaimers thereto appears at the end of this data sheet.

PRODUCTION DATA information is current as of publication date. Products conform to specifications per the terms of Texas Instruments standard warranty. Production processing does not necessarily include testing of all parameters.

TRF1400
RF TELEMETRY RECEIVERS
VHF/UHF RZ ASK REMOTE CONTROL RECEIVER

SLWS014E – JUNE 1996 – REVISED APRIL 1998

description (continued)

The TRF1400 VHF/UHF RZ ASK remote control receiver is available in a 24-pin SOIC (DW) package, and is characterized for operation over the temperature range of -40°C to 85°C . The DW package is available taped and reeled; add R suffix to device type when ordering (e.g., TRF1400DWR).

functional block diagram

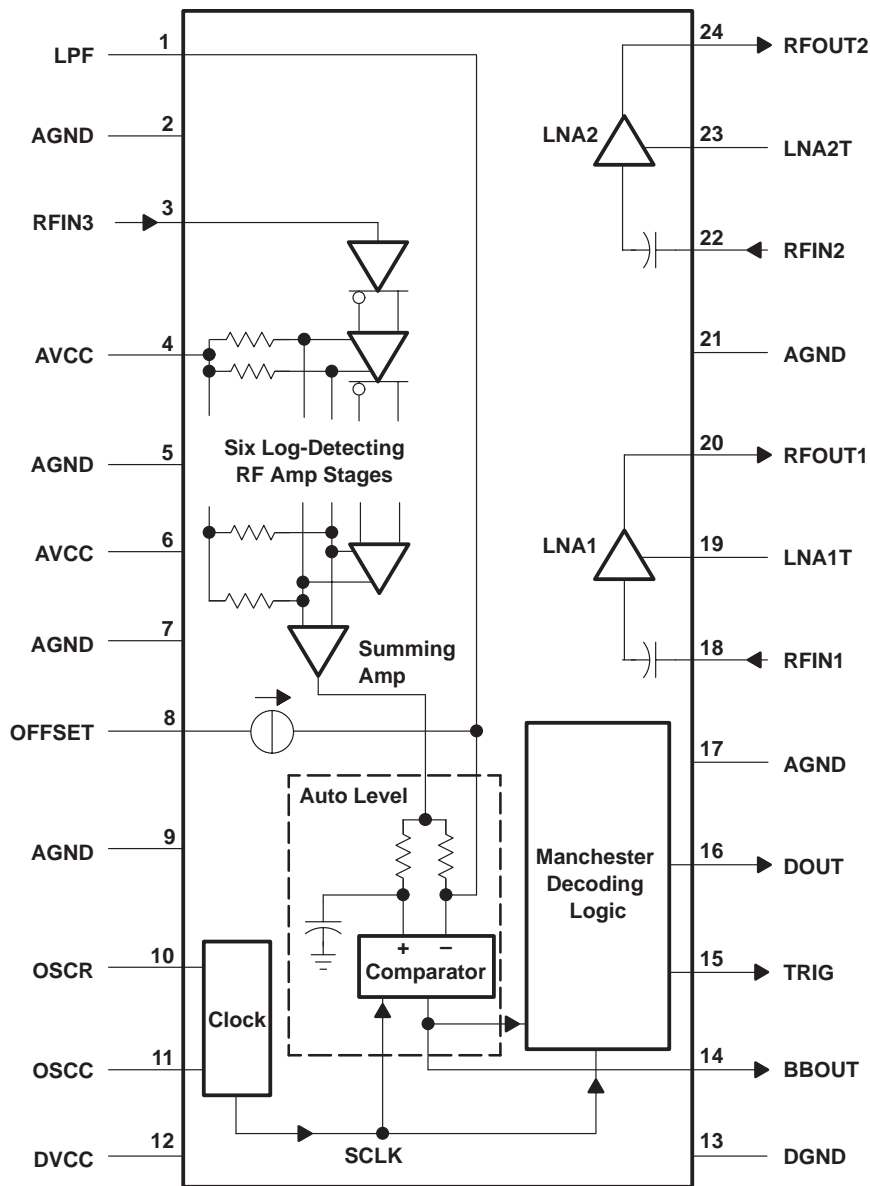

Terminal Functions

TERMINAL NAME	NO.	I/O	DESCRIPTION
AGND	2, 5, 7, 9, 17, 21		Analog ground for all internal analog circuits. AGND is not internally connected to digital ground (DGND). All analog signals are referenced to AGND.
AVCC	4, 6		Positive power supply voltage for all analog circuits — 4.5 V to 5.5 V
BBOUT	14	O	Baseband data output. BBOUT is the demodulated envelope of the recovered RF signal and is active with any received ASK signal coding format.
DGND	13		Digital ground for all internal logic circuits. DGND is not internally connected to analog ground (AGND).
DOUT	16	O	Data output. Data appearing at DOUT is a binary, TTL representation of the baseband data, and is only meaningful when Manchester-encoded ASK data is received. DOUT is active high and is internally pulled down.
DVCC	12		Positive power supply voltage for all digital circuits. DVCC is 4.5 V to 5.5 V. For best noise performance, DVCC should connect to AVCC at the power supply, not at the TRF1400 device.
LNA1T	19		Low-noise amplifier (LNA) 1 ground termination. LNA1T should be connected to AGND through a parallel resistor-capacitor bias network. If left unconnected, LNA1 is disabled.
LNA2T	23		Low-noise amplifier (LNA) 2 ground termination. LNA2T should be connected to AGND through a parallel resistor-capacitor bias network. If left unconnected, LNA2 is disabled.
LPF	1		Connection for external low-pass capacitor used in the average-detecting adaptive threshold circuitry.
OFFSET	8		Connection for external offset resistor. A resistor (1 M Ω suggested) sets the internal threshold detector offset voltage. Lowering the value of this resistor decreases device sensitivity.
OSCC	11		Internal oscillator frequency-setting capacitor. A capacitor, connected between OSCC and ground, in conjunction with a resistor connected between OSCR and OSCC, determines the speed of the internal clock oscillator (SCLK). The SCLK signal is used for processing the demodulated incoming data stream and controls the Manchester decoding and timing recovery logic sections of the device. The internal oscillator must be set to 10 times the received Manchester data rate for valid TRIG and DOUT, or to 5 times the received baseband data rate.
OSCR	10		Internal oscillator frequency-setting resistor. A resistor, connected between OSCR and OSCC, in conjunction with a capacitor connected between OSCC and ground determines the speed of the internal oscillator (SCLK). The SCLK signal is used for processing the demodulated incoming data stream and controls the Manchester decoding and timing recovery logic sections of the device. The internal oscillator must be set to 10 times the received Manchester data rate for valid TRIG and DOUT, or to 5 times the received baseband data rate.
RFIN1	18	I	RF input to first low-noise, high-gain amplifier stage
RFIN2	22	I	RF input to second low-noise, high-gain amplifier stage
RFIN3	3	I	RF input to the detecting RF amplifier stages. Filtered RF in the form of AM RZ ASK data at frequencies between 200 MHz and 450 MHz, at a baud rate between 500 Hz and 10 kHz can be applied to RFIN3 for detection and decoding.
RFOUT1	20	O	RF output of the first low-noise, high-gain amplifier
RFOUT2	24	O	RF output of the second low-noise, high-gain amplifier. Typically, the input of an external SAW or LC filter is connected to RFOUT2.
TRIG	15	O	Trigger output. TRIG pulses to indicate each new received data cell and is only meaningful when Manchester-encoded ASK data is received. TRIG is active high and is internally pulled down.

TRF1400
RF TELEMETRY RECEIVERS
VHF/UHF RZ ASK REMOTE CONTROL RECEIVER

SLWS014E – JUNE 1996 – REVISED APRIL 1998

absolute maximum ratings over operating free-air temperature range (unless otherwise noted)†

Supply voltage range, AVCC, DVCC (see Note 1)	–0.6 to 6 V
Input voltage range, V _I	–0.6 to 6 V
Continuous total power dissipation	180 mW
Operating free-air temperature range, T _A	–55°C to 85°C
Storage temperature range, T _{stg}	–65°C to 150°C
ESD protection, all terminals: human body model	2 kV
machine model	200 V
JEDEC latchup	150 mA or 11 V

† Stresses beyond those listed under “absolute maximum ratings” may cause permanent damage to the device. These are stress ratings only, and functional operation of the device at these or any other conditions beyond those indicated under “recommended operating conditions” is not implied. Exposure to absolute-maximum-rated conditions for extended periods may affect device reliability.

NOTE 1: Voltage values are with respect to GND.

recommended operating conditions

	MIN	NOM	MAX	UNIT
Supply voltage, V _{CC}	4.5		5.5	V
Input frequency, f _{in}	200		450	MHz
Operating free-air temperature, T _A	–40		85	°C
Minimum permissible AM modulation of RF envelope applied to RF Input, measured at –101 dBm		25%		

electrical characteristics as measured in the test circuit detailed in Figures 1 through 6 with f_{in} = 315 MHz over recommended ranges of supply voltage and operating free-air temperature, typical values are at V_{CC} = 5 V and T_A = 25°C (unless otherwise noted)

current consumption

PARAMETER	TEST CONDITIONS	MIN	TYP	MAX	UNIT
I _{CC} Average supply current from V _{CC}	I/O pins terminated with typical loads, Signal applied with a 5-kHz baseband data rate		2.7	3.5	mA
	I/O pins terminated with typical loads, Signal applied with a 2.5-kHz Manchester data rate		2.7	3.5	
	I/O pins terminated with typical loads, no data input		2.5		

digital interface

PARAMETER	TEST CONDITIONS	MIN	MAX	UNIT
V _{OH} High-level output voltage	DOUT, TRIG, BBOUT	I _{OH} = 3.2 mA	V _{CC} – 0.5	V
V _{OL} Low-level output voltage				

VSWR (voltage standing-wave ratio), ripple rejection

PARAMETER	TEST CONDITIONS	MIN	TYP	MAX	UNIT
VSWR into 50 Ω at RFIN1, RFOUT1, RFIN2, RFOUT2, RFIN3	With external LC matching network		2:1		V/V
Ripple rejection at BBOUT while maintaining BER = 1/100 (see Note 2)	1 MHz injected at AVCC and DVCC, Carrier level = –50 dBm		6% V _{CC}		

NOTE 2: BER (bit error rate = errors/number of bits) is qualified by integration of logic-level pulses (>50% high = 1, <50% low = 0). (See the System Design Considerations Using the TRF1400 RF Telemetry Receivers Application Report, TI literature number SLWA005, for more BER information.)



RF sensitivity/overload

PARAMETER	TEST CONDITIONS	MIN	TYP	MAX	UNIT
RF input level (average) at test board RF input required for BER 1/100 at 5 kHz baseband data rate, 2.5 kHz Manchester data rate (see Note 2)	$V_{CC} = 5\text{ V}$, $T_A = 25^\circ\text{C}$, $f_{in} = 315\text{ MHz}$, external SAW preselector bandpass filter (see Note 3)		-103	-101	dBm
Overload signal level at f_c with BER 1/100 at 5 kHz baseband data rate, 2.5 kHz Manchester data rate (see Note 2)	$V_{CC} = 5\text{ V}$, $T_A = 25^\circ\text{C}$, $f_{in} = 315\text{ MHz}$		-20		dBm

NOTES: 2. BER (bit error rate = errors/number of bits) is qualified by integration of logic-level pulses (>50% high = 1, <50% low = 0).
3. The SAW bandpass filter must have a rejection level greater than or equal to 50 dB at $\pm 0.5 f_c$, an insertion loss of less than or equal to 3 dB, and a -3 dB passband width of 0.2% f_c , where f_c is the passband center frequency of the SAW filter.

oscillator (internal clock)

PARAMETER	MIN	MAX	UNIT
Sample clock frequency, SCLK (5× baseband data rate, 10× Manchester data rate)	2.5	50	kHz
Frequency spread (process variation, temperature, V_{CC}), not including external component tolerance		±5%	

timing requirements over recommended ranges of supply voltage and operating free-air temperature

RF input data (see Figure 7)

	MIN	MAX	UNIT
t_r Rise time at RFIN1		$0.1 t_{w3}$	μs
t_f Fall time at RFIN1		$0.1 t_{w3}$	μs

received data

	MIN	MAX	UNIT
Baseband data frequency, AM RZ ASK	0.5	10	kHz
Manchester data frequency, AM RZ ASK	0.25	5	kHz
Pulse period tolerance for synchronization, valid TRIG and DOUT data		±8%	
Pulse duty cycle for synchronization, valid TRIG and DOUT data	49%	51%	
t_x Dead time between wakeup time and frame start time (for synchronization valid, TRIG and DOUT data) (see Figure 8)	$38 \div \text{SCLK}$	$317 \div \text{SCLK}$	ms
t_{w3} Duration, modulated RF carrier (see Figure 9)	100	2000	μs

switching characteristics over recommended ranges of supply voltage and operating free-air temperature

device latency for BBOUT, TRIG, DOUT (see Figure 9)

PARAMETER	MIN	TYP	MAX	UNIT
Delay time between power applied and output signal at BBOUT		10		ms
Demodulation delay time across device (RF Input to BBOUT)		10		μs
t_{d1} Delay time between BBOUT ↑ and TRIG ↑		$2.5 \div \text{SCLK}$		μs
t_{d2} Delay time between DOUT ↑ and TRIG ↑		$0.5 \div \text{SCLK}$		μs

RF carrier (see Figure 9)

PARAMETER	MIN	TYP	MAX	UNIT
t_{w0} Duration, logic 0 data cell		$2 t_{w3}$		μs
t_{w1} Duration, logic 1 data cell		$2 t_{w3}$		μs
t_{w2} Duration, trigger pulse		$0.5 \div \text{SCLK}$		μs

PARAMETER MEASUREMENT INFORMATION

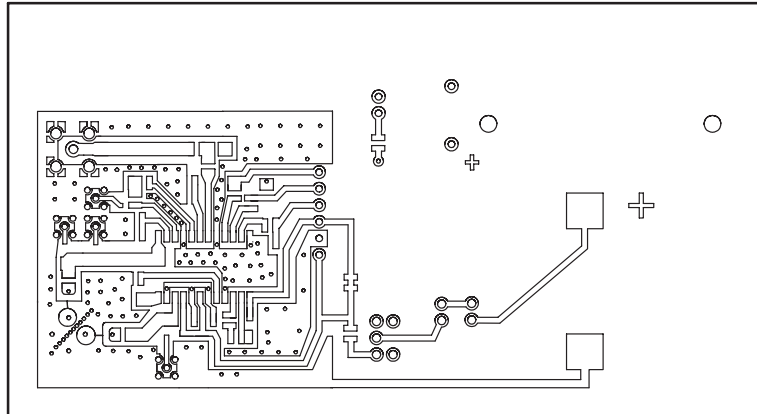

NOTE A: Circuit board material is 62 mil G-10 with 1-oz copper, dielectric constant = 4.5

Figure 2. TRF1400 Test Circuit Board Layout — Top Side

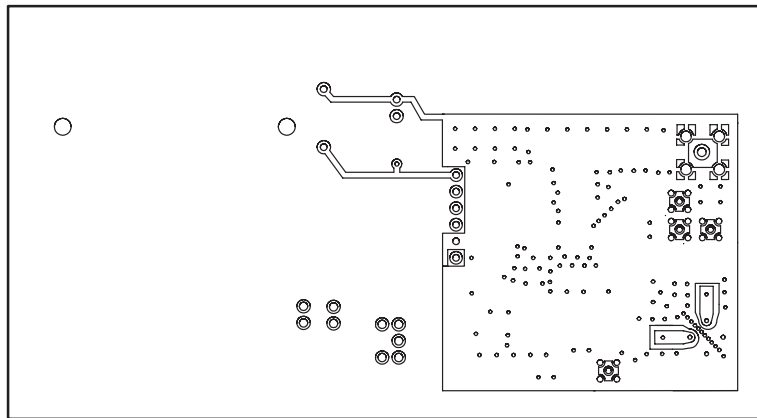

Figure 3. TRF1400 Test Circuit Board Layout — Bottom Side

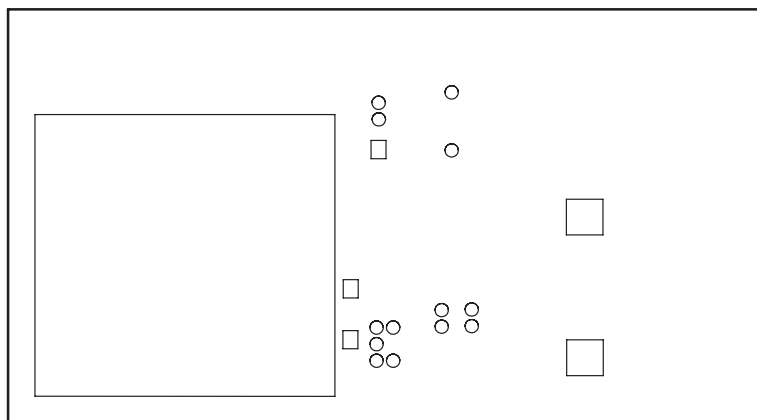

Figure 4. TRF1400 Test Circuit Board Solder Mask — Top Side

PARAMETER MEASUREMENT INFORMATION

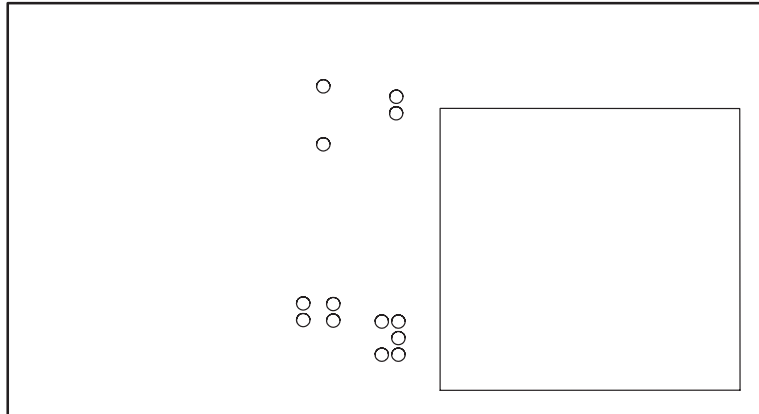

Figure 5. TRF1400 Test Circuit Board Solder Mask — Bottom Side

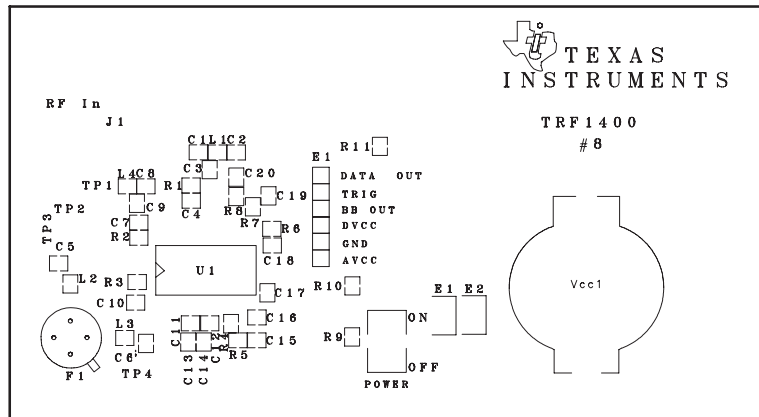

Figure 6. TRF1400 Test Circuit Board Silk Screen

PARAMETER MEASUREMENT INFORMATION

Table 1. TRF1400 315-MHz Test Circuit Parts List

DESIGNATORS	DESCRIPTION	VALUE	MANUFACTURER	MANUFACTURER P/N
C1	Capacitor	4 pF	Murata	GRM40C0G040C050V
C2, C3	Capacitor	22 pF	Murata	GRM40C0G220J050BD
C4, C7	Capacitor	100 pF	Murata	GRM40C0G101J050BD
C5	Capacitor	5 pF	Murata	GRM40C0G050D050BD
C6	Capacitor	1.5 pF	Murata	GRM40C0G1R5C050BD
C8	Capacitor	3 pF	Murata	GRM40C0G030C050BD
C9	Capacitor	18 pF	Murata	GRM40C0G180J050BD
C10	Capacitor	0.047 μ F	Murata	GRM40X7R473K050
C11, C12, C17, C19	Capacitor	2200 pF	Murata	GRM40X7R222K050BD
C13, C18, C20	Capacitor	0.022 μ F	Murata	GRM40X7R223K050BL
C14, C16	Capacitor, Tantalum [†]	4.7 μ F @ 6.3 V	Panasonic	ECS-T1AY475R
C15	Capacitor	220 pF, 5%	Murata	GRM40C0G221J050BD
E1	2-Pin Connector		3M	2340-6111-TN
E2	2-Pin Connector		3M	2340-6111-TN
E3	6-Pin Connector		3M	2340-6111-TN
H1, H2	Header Shunts		3M	929952-10
F1	SAW Filter	RFM 1211	RFM	RFM 1211
L1	Inductor	47 nH	Coilcraft	0805HS470TMBC
L2	Inductor	82 nH	Coilcraft	0805HS820TKBC
L3	Inductor	120 nH	Coilcraft	0805HS121TKBC
L4	Inductor	39 nH	Coilcraft	0805HS390TMBC
P1	RF SMA Connector		Johnson	142-0701-201
R1	Resistor	1.2 K Ω		
R2	Resistor	1.2 K Ω		
R3	Resistor	3 M Ω		
R4	Resistor	130 K Ω , 1%		
R5	Resistor	0 Ω		
R6, R8	Resistor	1K Ω		
R7	Resistor	100 Ω		
R9	Resistor	680 Ω		
R10	Resistor	short		
R11	Resistor	330 Ω		
S1	Switch		NKK	G-12AP
Vcc1	Battery Clip		Keystone	1061
B1X	Battery, Lithium	3.3-V Coin Cell (2 ea.)	Panasonic	CR2016
U1	Receiver IC	TRF1400	TI	TRF1400

[†] Tantalum capacitors are rated at 6.3 Vdc minimum.

PARAMETER MEASUREMENT INFORMATION

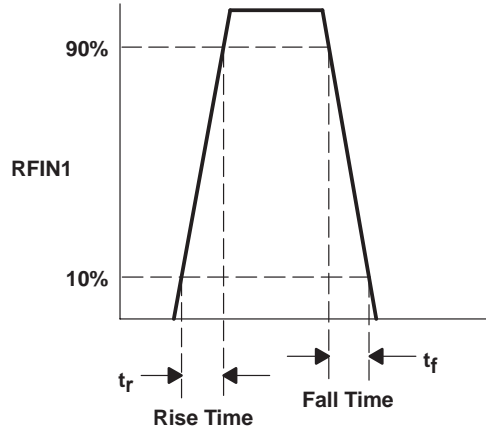

Figure 7. RFIN1 Rise and Fall Times

Table 2. TRF1400 LNA1 S Parameters

FREQ (MHz)	S11	∠ S11	S21	∠ S21	S12	∠ S12	S22	∠ S22
300	0.9541	-25.6217	4.7618	105.1213	0.0042	135.6601	0.6699	-17.8126
304	0.9555	-25.8350	4.7299	103.9028	0.0041	82.5760	0.6722	-17.5588
310	0.9569	-26.7244	4.6670	102.3880	0.0033	74.4905	0.6670	-18.0246
315	0.9474	-26.9720	4.6271	100.8973	0.0024	108.9183	0.6760	-17.9033
318	0.9543	-27.3058	4.6075	99.8886	0.0028	95.0878	0.6724	-17.9506
390	0.9391	-32.3782	3.8948	81.7216	0.0044	-108.3656	0.6911	-20.9576
418	0.9341	-34.8677	3.6575	75.8867	0.0019	165.4227	0.6965	-22.0900
434	0.9270	-35.8675	3.5286	72.4715	0.0043	113.6352	0.6991	-22.8623

NOTE 4: Input at RFIN1, output at RFOUT1, Z_O=50 Ω, R_{bias}=1.2 kΩ

PARAMETER MEASUREMENT INFORMATION

Table 3. TRF1400 LNA2 S Parameters

FREQ (MHz)	S11	∠ S11	S21	∠ S21	S12	∠ S12	S22	∠ S22
300	0.9607	-26.6188	4.8712	100.9061	0.0078	122.6680	0.6534	-24.4258
304	0.9655	-27.1490	4.8380	99.8060	0.0057	65.9066	0.6555	-24.5020
310	0.9554	-27.4384	4.7870	97.8264	0.0030	137.0205	0.6567	-25.1169
315	0.9612	-27.8929	4.7239	96.5227	0.0014	31.2221	0.6572	-24.8942
318	0.9615	-28.4482	4.7065	95.5964	0.0047	109.2950	0.6571	-25.0606
390	0.9461	-33.8905	3.9755	76.2949	0.0054	48.3449	0.6803	-28.0870
418	0.9389	-35.8847	3.7411	69.8410	0.0041	-119.9136	0.6811	-29.5353
434	0.9406	-36.8175	3.6130	66.0262	0.0046	102.9654	0.6839	-30.4657

NOTE 5: Input at RFIN2, output at RFOUT2, $Z_0=50\ \Omega$, $R_{bias}=1.2\ k\Omega$

Table 4. TRF1400 RSSI S Parameters

FREQ. (MHz)	S11	∠ S11
300	0.7937	-23.6001
304	0.7895	-24.0484
310	0.7923	-24.4377
315	0.7931	-24.5069
318	0.7934	-24.8835
390	0.7851	-30.0440
418	0.7736	-31.2657
434	0.7805	-32.5896

NOTE 6: Input at RFIN3, $Z_0=50\ \Omega$

PARAMETER MEASUREMENT INFORMATION

Manchester data format and timing

The TRF1400 requires specific Manchester data formatting and timing to decode and output Manchester serial data. For the TRF1400 to output meaningful function data at the TRIG and DOUT terminals, the incoming RF signal must have the Manchester-encoded binary format and timing shown in Figure 8 (for 50-kHz SCLK). A wakeup time and frame-start time is required for the device to synchronize with the incoming data. The wakeup time is designated by a data-bit 0 and data-bit 1 sequence repeated five times.

Figure 9 shows Manchester-encoded function data timing.

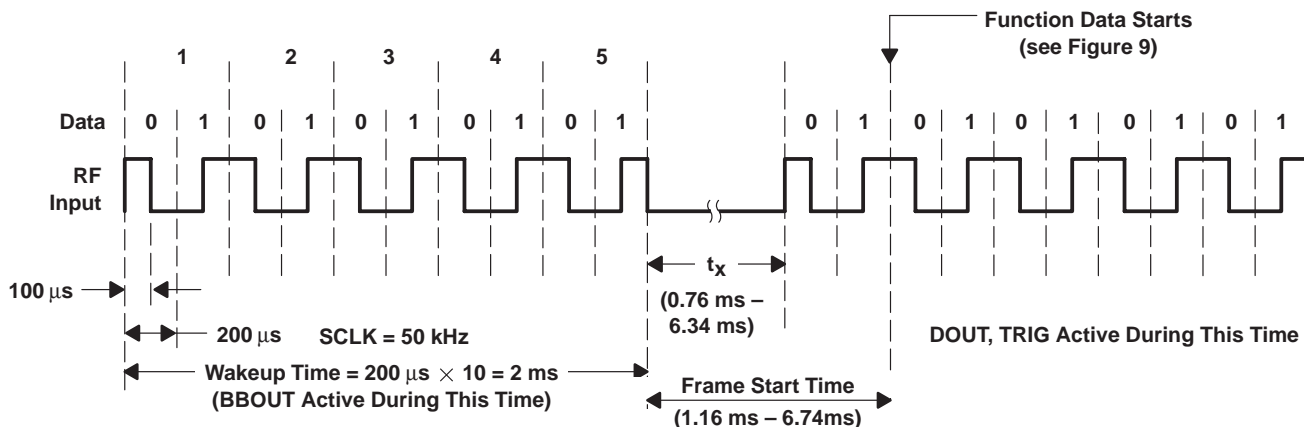

Figure 8. Manchester-Encoded RF Binary Data Format at RF Input

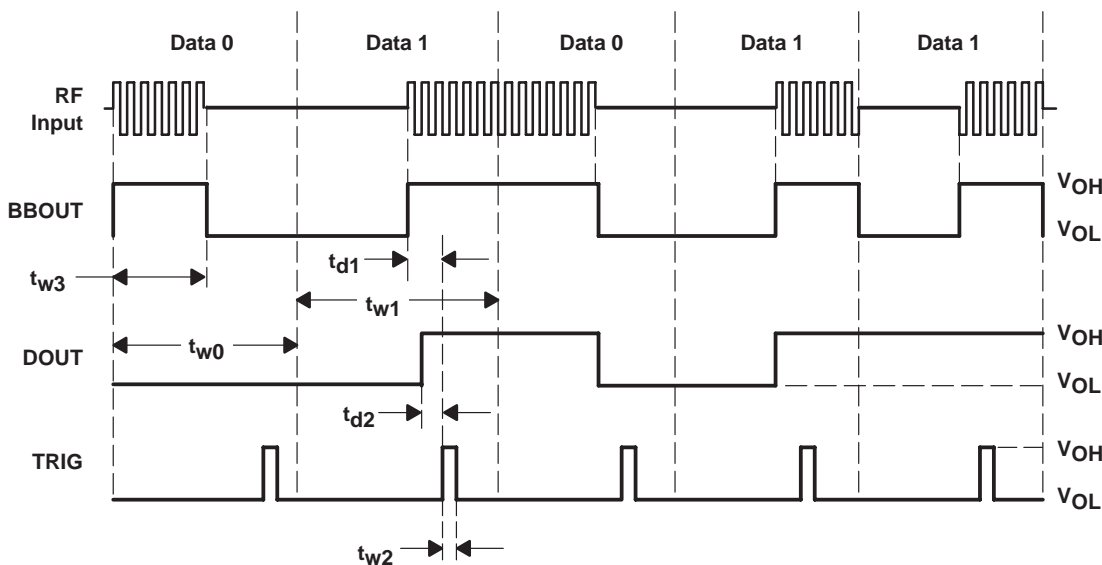

Figure 9. Manchester-Encoded Function Data Timing Diagram

PRINCIPLES OF OPERATION

general

The TRF1400 VHF/UHF RZ ASK remote control receiver demodulates AM RZ ASK modulated RF carriers between 200 MHz and 450 MHz with a 500-Hz to 10-kHz baseband data rate or a 250-Hz to 5-kHz Manchester data rate. A general signal flow is shown in Figure 10.

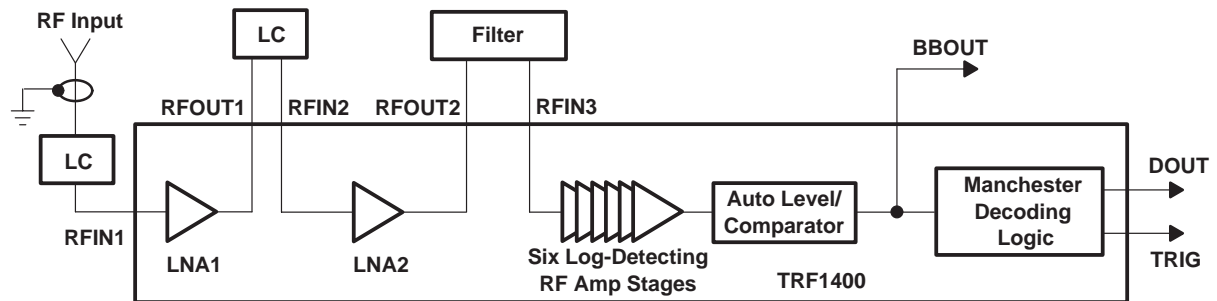

Figure 10. TRF1400 Signal Flow

signal reception

The RF signal is collected by an antenna and then passed through an external LC matching network to bandpass filter the signal and compensate for various antenna loading impedances. The signal is then input to the RFIN1 terminal of the TRF1400.

signal path through device

The RF signal applied to the RFIN1 terminal is amplified by LNA1 and typically passed through an external LC matching network before being applied to the input of LNA2. The combined gain of the two LNAs is 40 dB, with an input 1-dB compression point of -80 dBm and a noise figure of 5 dB (nominal). The amplified signal is output at RFOUT2 and passed through an external preselector bandpass filter before being applied to the third stage of amplification at terminal RFIN3.

The third stage of amplification consists of an amplifier with a single-ended input and differential outputs followed by six high-gain differential log-detecting amplifier stages with an equivalent gain of 60 dB (nominal), which forms a detector circuit. First, the signal is converted to a differential signal for increased noise immunity. Next, the differential signal is passed through the six high-gain differential log-detecting amplifiers. Each log-detecting amplifier is biased such that when an RF signal is present, an imbalance is caused in its bias circuit. The imbalance in each of the six stages is converted to a voltage that is then summed into a baseband envelope representation of the RF signal. This signal then passes through an autoleveling circuit before being applied to a comparator to produce the TTL-level baseband signal output that appears at BBOUT. An external low-pass filter connected to BBOUT attenuates high-frequency transients in the output signal.

The demodulated signal is also applied to the Manchester decoding and timing recovery logic section of the TRF1400. The Manchester Decoding Logic section has two outputs, TRIG and DOUT, which should be externally low-pass filtered to attenuate high-frequency transients. The signals appearing at these outputs are meaningful only when the received Manchester-encoded data is formatted and timed as shown in Figure 9.

When Manchester-encoded data is received and demodulated, Manchester serial data is output at DOUT and a trigger pulse is output at TRIG. The TRIG pulse rises at the start of each decoded data bit appearing at DOUT.

TRF1400

RF TELEMETRY RECEIVERS

VHF/UHF RZ ASK REMOTE CONTROL RECEIVER

SLWS014E – JUNE 1996 – REVISED APRIL 1998

PRINCIPLES OF OPERATION

frequency adjustment

The TRF1400 requires no manual alignment. The receive frequency is dependent only on the choice of external matching networks and preselecting filters used. In that respect, the user has only to stock a different set of external components for each frequency, and no manual alignment or end-of-line frequency programming is required. Although the combination of the TRF1400 and test circuit/demo board (Figures 1 – 6) is optimized for frequencies below 360 MHz, operation at reduced performance levels is possible at higher frequencies.

external components and device performance

Whereas the TRF1400 uses a minimum of external components in the typical application, the choice of those components greatly affects the performance of the device. When a SAW (surface acoustic wave) preselector is used, the selectivity (out-of-band rejection) and sensitivity of the TRF1400 are optimized as a result of the high Q of SAW devices. If an LC preselector is used, these parameters change and the overall performance of the TRF1400 is reduced, but can still meet the requirements of many end-equipment applications.

An external resistor connected between OFFSET and ground adjusts the internal offset voltage of the receiver decoding section to maximize the noise rejection of the device. While a 3-M Ω resistor is suggested, this value can be changed to minimize toggling of outputs DOUT, TRIG, and BBOUT during periods of nonvalid received code.

decoder interface

For baseband operation, a decoder can be interfaced directly to the TRF1400 using the baseband-data output (BBOUT) of the device.

For Manchester operation, a standard microcontroller decoder must know when to poll its input for data. The TRF1400 provides an output terminal (TRIG) for this purpose that pulses on each valid received data cell. In this system configuration, Manchester-encoded binary data must be used in the format described in the following paragraphs to allow the TRF1400 to synchronize properly and produce the TRIG and DOUT outputs.

internal clock/synchronization

An internal clock (SCLK) is used by the TRF1400 for processing the demodulated incoming data stream and for controlling the Manchester-decoding and timing-recovery logic sections of the device. The frequency of SCLK is set by an external resistor connected between the OSCR and OSCC terminals and an external capacitor connected between OSCC and ground, and is adjustable between 2.5 kHz and 50 kHz.

For baseband output, SCLK is set to 5 times the received baseband data rate (500 Hz to 10 kHz). Incoming baseband data is then sampled at 5 times its transmitted data rate. TTL-level baseband data is output at BBOUT whenever the TRF1400 receives ASK-modulated data in any format. This provides compatibility with systems that use other code formatting, and whose serial data decoders do not require the DOUT or TRIG outputs from the receiver.

For Manchester data output, SCLK must be set to 10 times the received Manchester-encoded data rate (250 Hz to 5 kHz) for the output signals at TRIG and DOUT to be meaningful. The high sampling rate (10 \times) ensures accurate correlation of the received signal.

The received Manchester data rate (set by a clock on the transmitter/encoder end) can vary as much as $\pm 8\%$ and TRF1400 synchronization still results. This allows for frequency drift due to external component tolerances and temperature changes on the transmitter end. At the TRF1400 end, a $\pm 8\%$ frequency variation is also allowed. Thus, the total permissible frequency variation from transmitter clock to receiver clock can be as much as $\pm 16\%$. For example, if a serial Manchester data rate of 1.5 kHz is used at the encoder/transmitter end, then the TRF1400 sample clock oscillator (SCLK) must be set to 10 times the transmitted data rate, or 15 kHz. SCLK is allowed to vary $\pm 8\%$ in frequency, from 13.8 kHz to 16.2 kHz in this case, and the TRF1400 synchronizes successfully to the incoming data.



POST OFFICE BOX 655303 • DALLAS, TEXAS 75265

PRINCIPLES OF OPERATION

internal clock/synchronization (continued)

The data rate of the incoming data itself can also vary the same amount. It is left to the user to design the system such that the transmitter/encoder data rate drifts $\pm 8\%$ or less. The TRF1400 can introduce as much as a $\pm 5\%$ frequency variation due to its internal tolerances and semiconductor process variations, so the external resistor and capacitor values used with the TRF1400 can have up to a $\pm 3\%$ value tolerance.

The frequency of the internal clock oscillator is set by connecting a resistor between OSCR and OSCC and a capacitor between OSCC and ground. The following equation defines the oscillator frequency (SCLK speed) as a function of the external resistor and capacitor:

$$F_{osc} = \frac{1}{1.386 \times (R_{ext} + R_s) \times (C_{ext} + C_p)}$$

- Where:
- R_{ext} is the external resistor connected between OSCR and OSCC.
 - R_s is the internal series resistance, typically 1.9 k Ω or less.
 - C_{ext} is the external capacitor connected between OSCC and ground.
 - C_p is parasitic capacitance and is dependent on board layout — typical value is 8.5 pF.

For minimum current draw, large values (in the thousands of ohms) for R_{ext} should be used. Typical R_{ext} values and the resulting SCLK frequency when $C_{ext} = 100$ pF are shown in Figure 11.

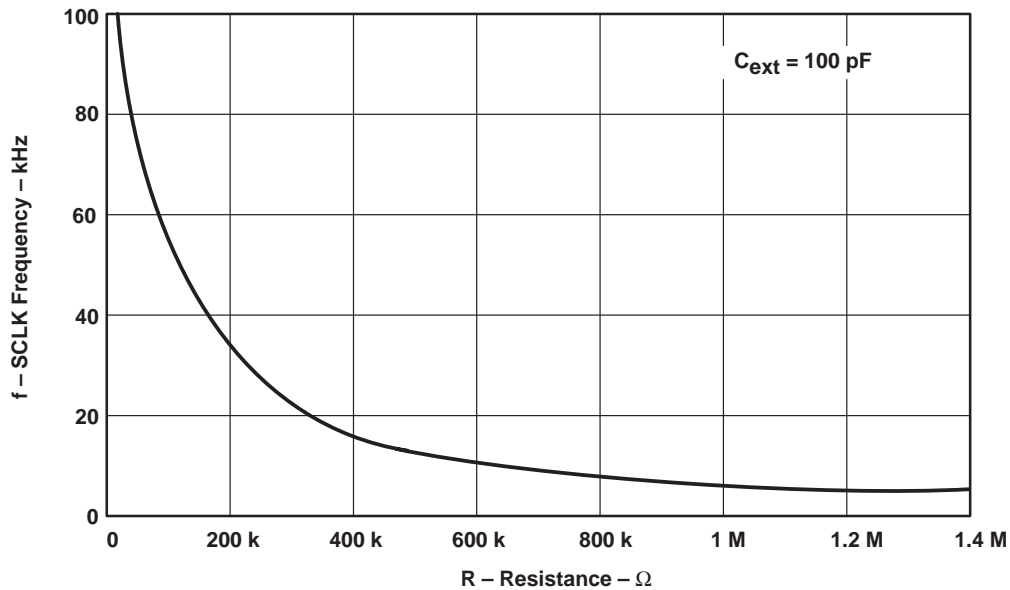

Figure 11. External Resistance Versus Sample Clock Frequency

TRF1400
RF TELEMETRY RECEIVERS
VHF/UHF RZ ASK REMOTE CONTROL RECEIVER

SLWS014E – JUNE 1996 – REVISED APRIL 1998

APPLICABLE REGULATIONS

Receiver design, as well as transmitter design, is regulated throughout the world. Since the TRF1400 is targeted for world-wide sales, the applicable standard for each region must be considered when the device is to be used in systems to be successfully marketed in that region. For this reason, the TRF1400 conforms to all requirements shown in Figure 12 and Table 5. The primary specifications of most of the standards address carrier frequency and spurious emissions.

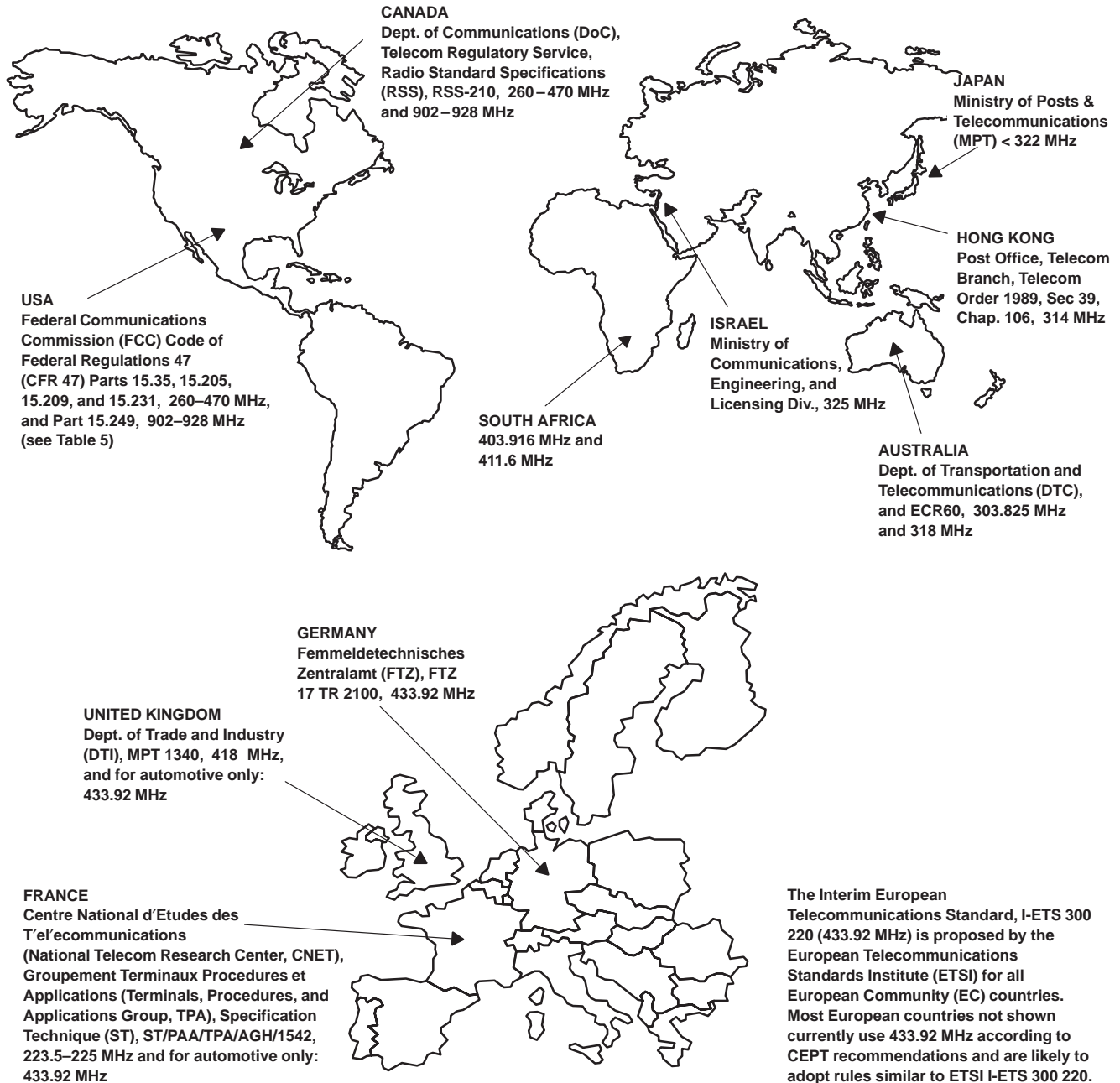

Figure 12. World-Wide Receiver Regulations

APPLICABLE REGULATIONS

Table 5. World-Wide Regulations

REGION	REGULATION	FREQUENCY
USA	Federal Communications Commission (FCC) Code of Federal Regulations 47 (CFR 47) Parts 15.35, 15.205, 15.209, 15.231, and 15.249 (see Note 7)	260 MHz – 470 MHz (Part 15.35, 15.205, 15.209) 902 MHz – 928 MHz (Part 15.249, see Note 4)
Germany	Femmeldetechnisches Zentralamt (FTZ), FTZ 17 TR2100	433.92 MHz
France	Centre National d'Etudes des T'el'ecommunications (National Telecom Research Center, CNET), Groupement Terminaux Procedures et Applications (Terminals, Procedures and Applications Group, TPA), Specification Technique (ST), ST/PAA/TPA/AGH/1542	223.5 MHz – 225 MHz (automotive only)
United Kingdom	Dept. of Trade and Industry (DTI), MPT 1340	418 MHz 433.92 MHz (automotive only)
Japan	Ministry of Posts and Telecommunications (MPT)	< 322 MHz
Canada	Dept. of Communications (DoC), Telecom Regulatory Service, Radio Standard Specifications (RSS), RSS-210	260 MHz – 470 MHz (RSS-210) 902 MHz – 928 MHz
Hong Kong	Post Office, Telecom Branch, Telecom Order 1989, Sec 39, Cap. 106	314 MHz
Australia	Dept. of Transportation and Telecommunications (DTC), and ECR60	303.825 MHz and 318 MHz
Israel	Ministry of Communications, Engineering & Licensing Div.	325 MHz
South Africa		403.916 MHz and 411.6 MHz

NOTE 7: Although the FCC Part 15.231 allows low-power unlicensed radios in the range of 260 MHz to 470 MHz, not all frequencies in this range are desirable. This is due to emission restrictions applying to fundamentals and harmonics in various forbidden bands as defined in Parts 15.205 and 15.209. USA frequencies shown above conform to these additional restrictions and are commonly used in the USA. Under Part 15.249, transmitters may continuously radiate 50 000 $\mu\text{V}/\text{m}$ at 3 meters with simple modulation. Part 15.247 permits still higher power, but must use true spread-spectrum modulation. See FCC CFR 47, Part 47, Part 15 for details.

TRF1400
RF TELEMETRY RECEIVERS
VHF/UHF RZ ASK REMOTE CONTROL RECEIVER

SLWS014E – JUNE 1996 – REVISED APRIL 1998

MECHANICAL DATA

DW (R-PDSO-G)**

PLASTIC SMALL-OUTLINE PACKAGE

16 PIN SHOWN

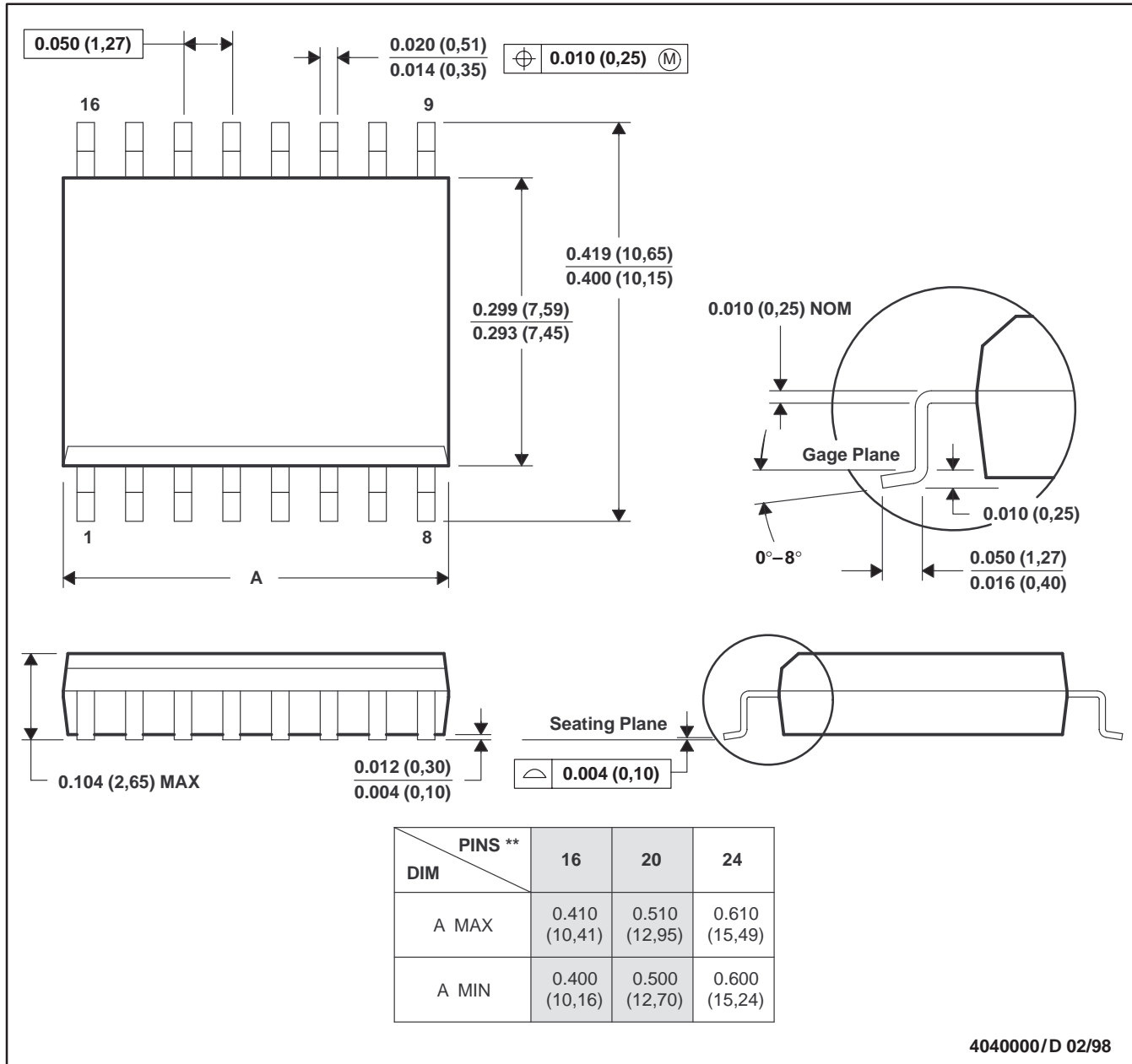

- NOTES: A. All linear dimensions are in inches (millimeters).
 B. This drawing is subject to change without notice.
 C. Body dimensions do not include mold flash or protrusion not to exceed 0.006 (0,15).
 D. Falls within JEDEC MS-013

IMPORTANT NOTICE

Texas Instruments and its subsidiaries (TI) reserve the right to make changes to their products or to discontinue any product or service without notice, and advise customers to obtain the latest version of relevant information to verify, before placing orders, that information being relied on is current and complete. All products are sold subject to the terms and conditions of sale supplied at the time of order acknowledgement, including those pertaining to warranty, patent infringement, and limitation of liability.

TI warrants performance of its semiconductor products to the specifications applicable at the time of sale in accordance with TI's standard warranty. Testing and other quality control techniques are utilized to the extent TI deems necessary to support this warranty. Specific testing of all parameters of each device is not necessarily performed, except those mandated by government requirements.

CERTAIN APPLICATIONS USING SEMICONDUCTOR PRODUCTS MAY INVOLVE POTENTIAL RISKS OF DEATH, PERSONAL INJURY, OR SEVERE PROPERTY OR ENVIRONMENTAL DAMAGE ("CRITICAL APPLICATIONS"). TI SEMICONDUCTOR PRODUCTS ARE NOT DESIGNED, AUTHORIZED, OR WARRANTED TO BE SUITABLE FOR USE IN LIFE-SUPPORT DEVICES OR SYSTEMS OR OTHER CRITICAL APPLICATIONS. INCLUSION OF TI PRODUCTS IN SUCH APPLICATIONS IS UNDERSTOOD TO BE FULLY AT THE CUSTOMER'S RISK.

In order to minimize risks associated with the customer's applications, adequate design and operating safeguards must be provided by the customer to minimize inherent or procedural hazards.

TI assumes no liability for applications assistance or customer product design. TI does not warrant or represent that any license, either express or implied, is granted under any patent right, copyright, mask work right, or other intellectual property right of TI covering or relating to any combination, machine, or process in which such semiconductor products or services might be or are used. TI's publication of information regarding any third party's products or services does not constitute TI's approval, warranty or endorsement thereof.