

*Evaluation Board Documentation*

***TRF8010 RF Transmit Driver 4.8  
Volt GSM Application***

---

---

---

*APPLICATION BRIEF: SWRA010*

*Wireless Communications Business Unit*

*Digital Signal Processing Solutions  
21 November 1997*



## **IMPORTANT NOTICE**

Texas Instruments (TI) reserves the right to make changes to its products or to discontinue any semiconductor product or service without notice, and advises its customers to obtain the latest version of relevant information to verify, before placing orders, that the information being relied on is current.

TI warrants performance of its semiconductor products and related software to the specifications applicable at the time of sale in accordance with TI's standard warranty. Testing and other quality control techniques are utilized to the extent TI deems necessary to support this warranty. Specific testing of all parameters of each device is not necessarily performed, except those mandated by government requirements.

Certain application using semiconductor products may involve potential risks of death, personal injury, or severe property or environmental damage ("Critical Applications").

**TI SEMICONDUCTOR PRODUCTS ARE NOT DESIGNED, INTENDED, AUTHORIZED, OR WARRANTED TO BE SUITABLE FOR USE IN LIFE-SUPPORT APPLICATIONS, DEVICES OR SYSTEMS OR OTHER CRITICAL APPLICATIONS.**

Inclusion of TI products in such applications is understood to be fully at the risk of the customer. Use of TI products in such applications requires the written approval of an appropriate TI officer. Questions concerning potential risk applications should be directed to TI through a local SC sales office.

In order to minimize risks associated with the customer's applications, adequate design and operating safeguards should be provided by the customer to minimize inherent or procedural hazards.

TI assumes no liability for applications assistance, customer product design, software performance, or infringement of patents or services described herein. Nor does TI warrant or represent that any license, either express or implied, is granted under any patent right, copyright, mask work right, or other intellectual property right of TI covering or relating to any combination, machine, or process in which such semiconductor products or services might be or are used.

## **TRADEMARKS**

TI is a trademark of Texas Instruments Incorporated.

Other brands and names are the property of their respective owners.

## CONTACT INFORMATION

PIC TELEPHONE	(972) 644-5580
PIC FAX	(972) 480-7800
HP SUPPORT LINE	(972) 480-7872
PIC email	sc-infomaster@ti.com

## Contents

<b>Abstract</b> .....	<b>6</b>
<b>Product Support</b> .....	<b>7</b>
The TI Advantage Extends Beyond RF to Every Other Major Wireless System Block.....	7
Related Documentation .....	8
World Wide Web.....	8
Email .....	8
<b>Evaluation Board Mechanical Outline (Top View)</b> .....	<b>9</b>
<b>Evaluation Board Schematic</b> .....	<b>10</b>
<b>Typical RF Performance</b> .....	<b>11</b>
<b>Test Bench Diagram</b> .....	<b>12</b>
<b>Evaluation Board Disclaimer</b> .....	<b>14</b>

## Figures

Figure 1. TRF8010 Evaluation Board Mechanical Outline (top view).....	9
Figure 2. Evaluation Board Schematic for GSM. ....	10
Figure 3. Typical Pout/Gain/PAE vs. Pin for GSM. ....	11
Figure 4. Test Bench Configuration.....	12

# TRF8010 RF Transmit Driver 4.8 Volt GSM Application

---

---

---

## Abstract

The evaluation board documentation for the TRF8010 RF Transmit Driver is primarily for device assessment. Included in this documentation are the following:

- ❑ The Evaluation Board Mechanical Outline
- ❑ The Evaluation Board Schematic for GSM. The schematic also includes a component list describing the resistors, inductors, and capacitors, along with the suppliers and board material specifications.
- ❑ A Typical RF Performance Graph
- ❑ The Test Bench Diagram with organized instructions for configuration.

## Product Support

### The TI Advantage Extends Beyond RF to Every Other Major Wireless System Block

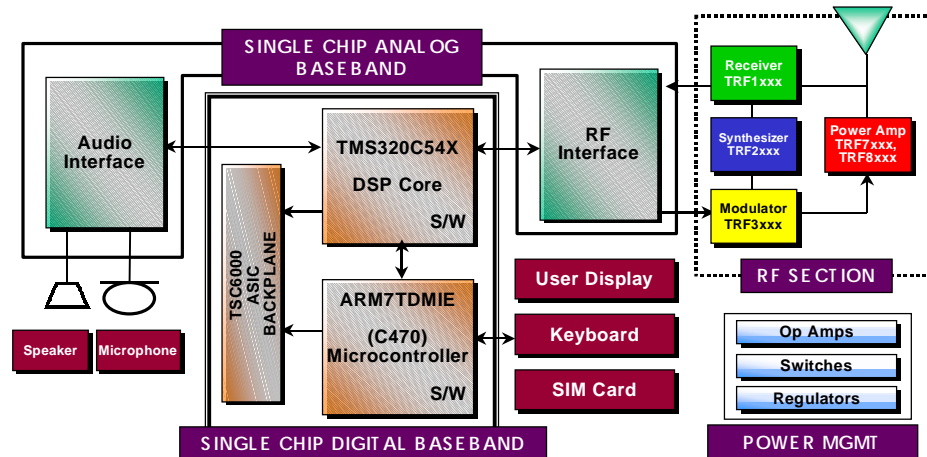

#### Digital Baseband

TI's single-chip Digital Baseband Platform, combines two high-performance core processors – a digital signal processor tailored for digital wireless applications and a microcontroller designed specifically for low-power embedded systems. The customizable platform helps wireless digital telephone manufacturers lower component counts, save board space, reduce power consumption, introduce new features, save development costs and achieve faster time to market, at the same time giving them flexibility and performance to support any standard worldwide.

#### Analog Baseband

TI analog baseband components provide a Mixed-signal bridge between the real world of analog signals and digital signal processors, the key enabling technology of the digital wireless industry. Using a seamless architecture for wireless communications technology, TI matches its baseband interfaces, radio frequency ICs and power management ICs to digital signal processing engines to create complete DSP Solutions for digital wireless systems.

#### Power Management

TI provides power management solutions with integration levels designed to meet the needs of a range of wireless applications. From discrete LDOs and voltage supervisors to complete power supplies for the baseband section, TI power management solutions play an important role in increasing wireless battery life, time-to-market and system functionality.

**For more information visit the Wireless Communications web site at [www.ti.com/sc/docs/wireless/home.htm](http://www.ti.com/sc/docs/wireless/home.htm).**



## Related Documentation

The following list specifies product names, part numbers, and literature numbers of corresponding TI documentation.

- *TRF8010 900-MHz RF Transmit Driver*, Literature number SLWS031B
- *TRF8010 Product Bulletin*, Literature Number SLWT003

## World Wide Web

Our World Wide Web site at [www.ti.com](http://www.ti.com) contains the most up to date product information, revisions, and additions. Users registering with TI&ME can build custom information pages and receive new product updates automatically via email.

## Email

For technical issues or clarification on switching products, please send a detailed email to [sc-infomaster@ti.com](mailto:sc-infomaster@ti.com). Questions receive prompt attention and are usually answered within one business day.



## Evaluation Board Mechanical Outline (Top View)

Figure 1. TRF8010 Evaluation Board Mechanical Outline (top view)

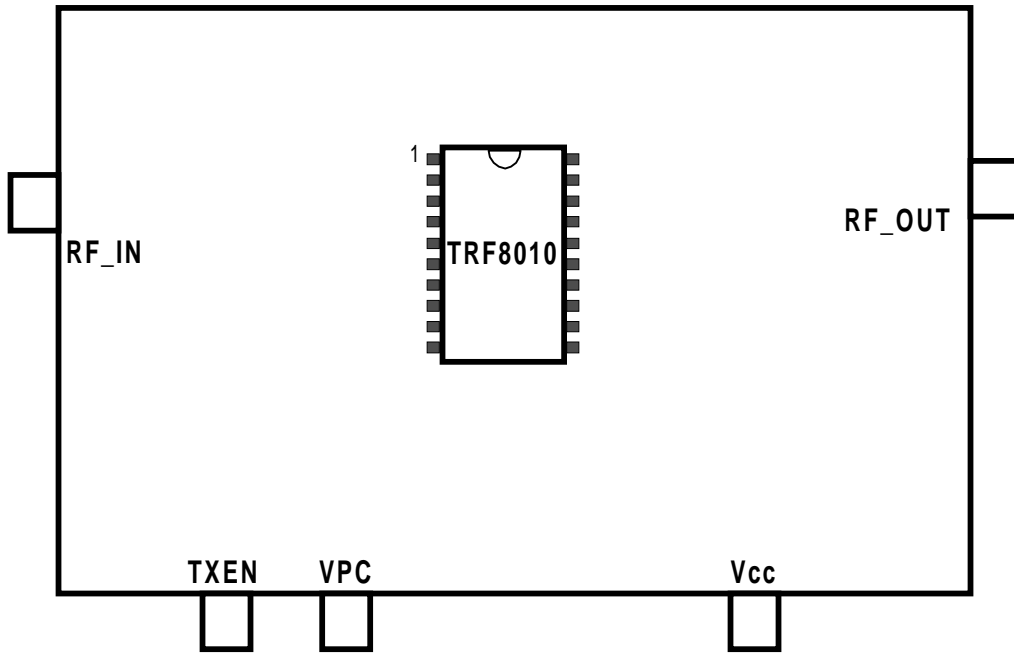

## Evaluation Board Schematic

Figure 2. Evaluation Board Schematic for GSM.

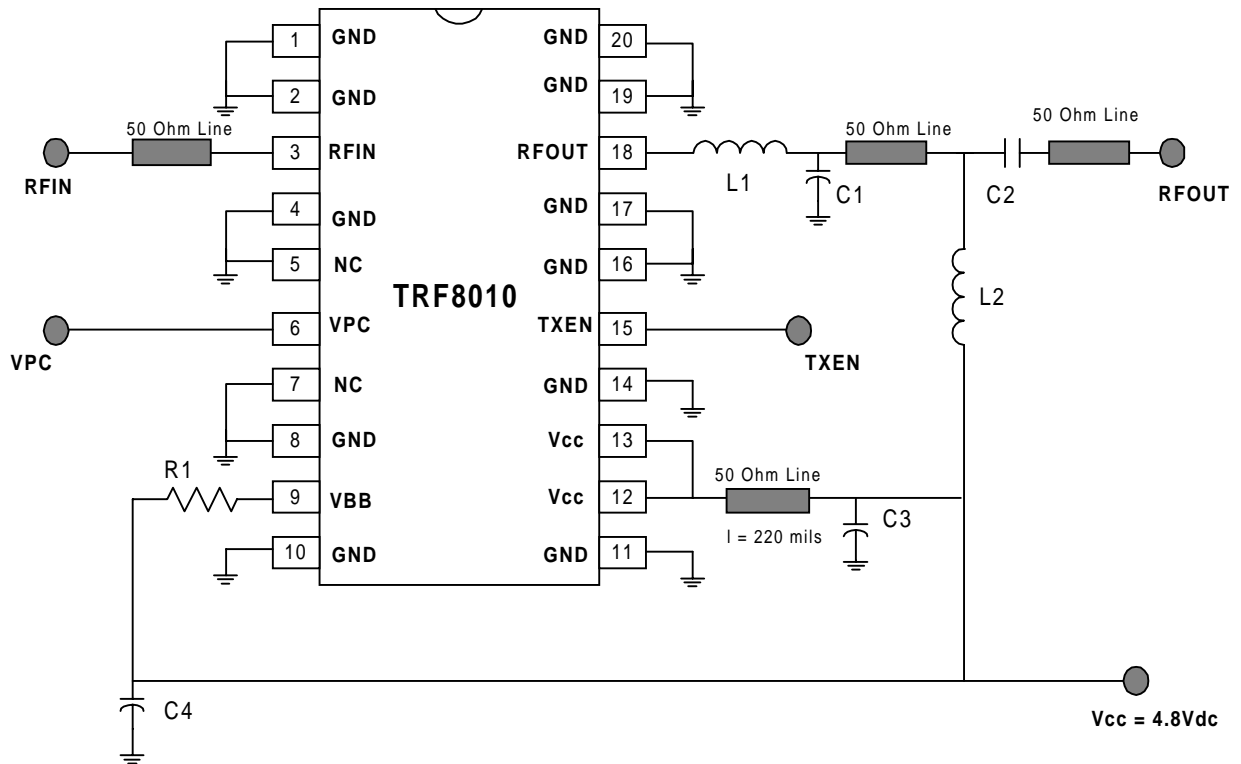

### Component List:

#### Resistor (Ohms)

R1 = 180

#### Inductor (nH)

L1 = 6.8  
L2 = 100

#### Capacitor (pF)

C1 = 3.3  
C2 = 100  
C3 = 100  
C4 = 1000

#### Suppliers:

- [IMS](#)  
RCI-0603 series ( resistors )
- [Toko](#)  
LL1608 series ( inductors )
- [Murata](#)  
GRM36C series ( capacitors )  
GRM36X series ( capacitors )

**Board Material Specifications:** Type FR4 ;  $\epsilon = 4.3$  ;  $h = 12$  mils



# Typical RF Performance

Figure 3. Typical Pout/Gain/PAE vs. Pin for GSM.

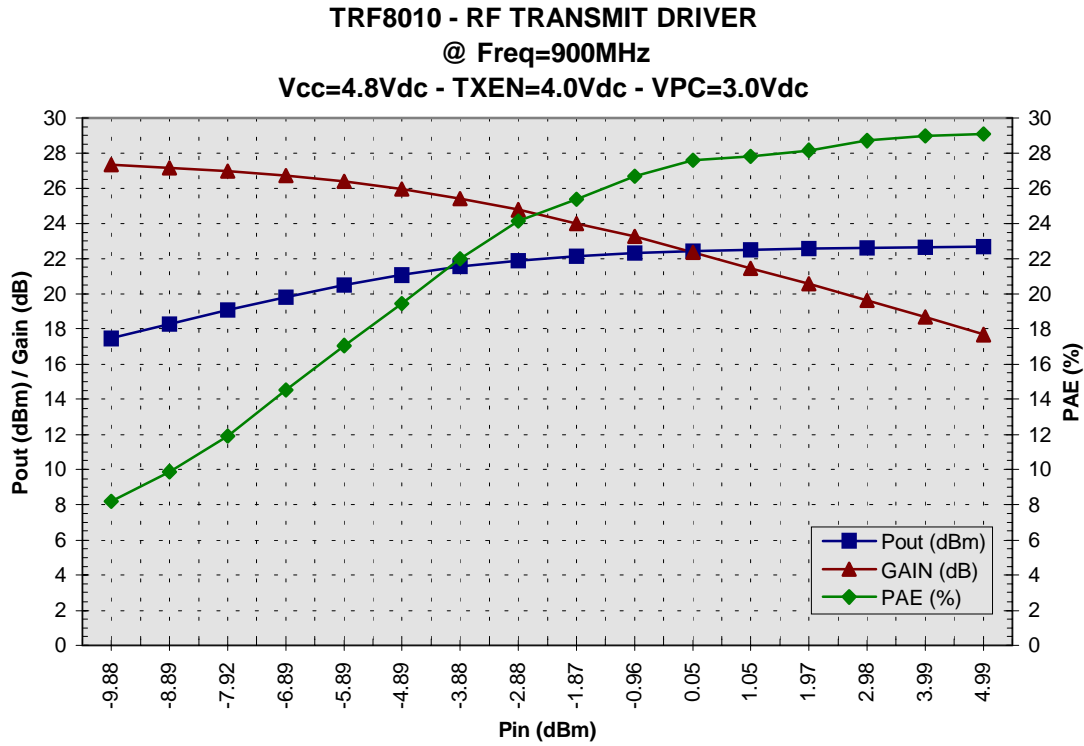

## Test Bench Diagram

Figure 4. Test Bench Configuration.

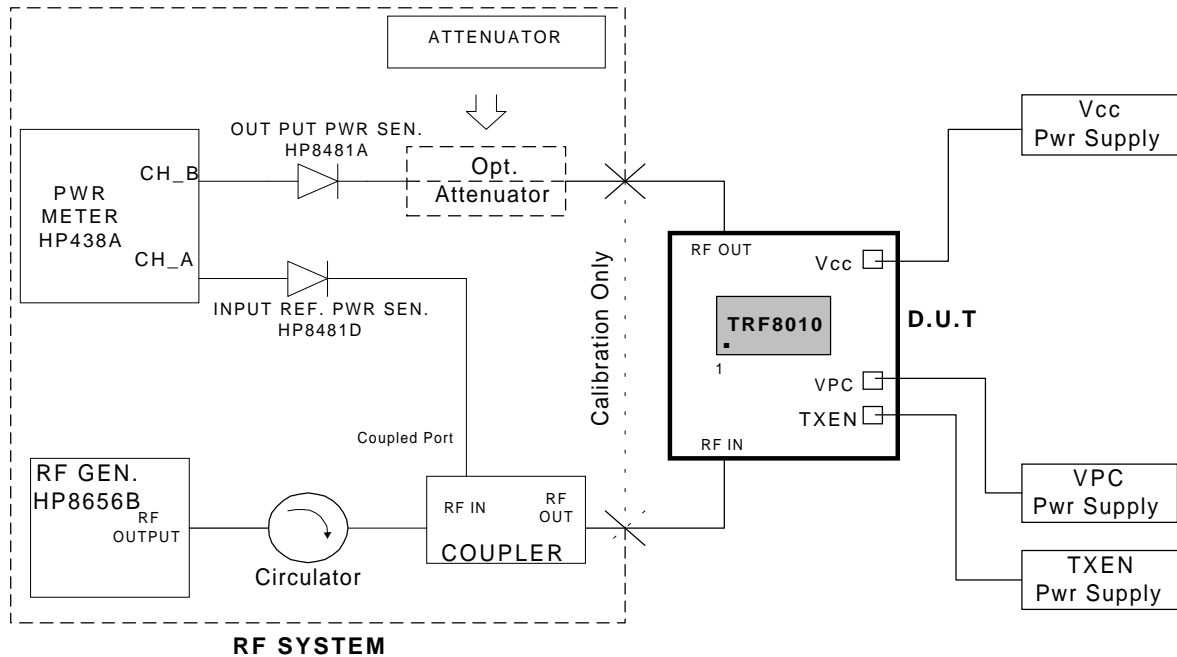

- 1) Configure Test Bench as shown.
- 2) Calibrate RF SYSTEM - less Device Under Test.
  - a) Zero and calibrate POWER METER, POWER SENSORS.
  - b) Set RF power and frequency on RF GENERATOR.
  - c) RF Input Calibration:
 

Offset Channel A of POWER METER by the difference between the reading of Channel B and Channel A. Verify that Channel A reading and Channel B reading are the same after offsetting.
  - d) RF Output Calibration:
 

Attach an Attenuator to OUTPUT POWER SENSOR. Offset Channel B of POWER METER by the difference between the reading of Channel A and Channel B. Verify that Channel A reading and Channel B reading are the same after offsetting.

- 3) Device D.C. Power-up



- a) Set *Vcc Power Supply* to 4.8Vdc.
- b) Set *TXEN Power Supply* to [ *Vcc* - 0.8Volts ].
- c) Set *VPC Power Supply* to

- \* 3.0Vdc for the Power Test.

- \* 0 to 3.0 Volts for VPC Control Test.

**NOTE: Ensure that *Vcc* is always 4.8V during RF test. Adjustment of *Vcc Power Supply* may be required.**



## Evaluation Board Disclaimer

Please note that the enclosed evaluation boards are experimental Printed Circuit Boards and are therefore only intended for device evaluation.

We would like to draw your attention to the fact that these boards have been processed through one or more of Texas Instruments' external subcontractors which have not been production qualified.

Device parameters measured, using these boards, are not representative of any final datasheet or of a final production version. Texas Instruments does not represent or guarantee that a final version will be made available after device evaluation.

THE EVALUATION BOARDS ARE SUPPLIED WITHOUT WARRANTY OF ANY KIND, EXPRESSED, IMPLIED OR STATUTORY, INCLUDING BUT NOT LIMITED TO, ANY IMPLIED WARRANTY OF MERCHANTABILITY OR FITNESS FOR A PARTICULAR PURPOSE.

TEXAS INSTRUMENTS ACCEPTS NO LIABILITY WHATSOEVER ARISING AS A RESULT OF THE USE OF THESE BOARDS.