

* slna 145sb

transceiver optimised preamplifier

Thankyou for buying muTek limited's SLNA 145sb transceiver optimised preamplifier. Although it has been custom designed for the Yaesu FT290R, it will also find application in other transceivers for which no complete front-end modification is available. The installation notes below refer to the FT290: we regret that we have no detailed information available regarding installation of the unit in other transceivers.

There are usually two reasons for the less than adequate sensitivity of current transceivers. Firstly, the receiver designer's brief includes a dynamic range specification which leads him to balance large signal handling with sensitivity. With devices currently available at prices the transceiver manufacturer is prepared to pay, the balance comes-out to around 4dB noise-figure and 70dB intermodulation-free dynamic range in ssb bandwidths.

The second point is that, also to save money, designers shy away from the use of electromechanical relays for antenna changeover switching and tend to use various forms of diode switch. These inevitably lead to greater insertion losses than suitable relays, approaching 4dB in some circumstances. Thus it's not unusual for the overall noise figure to reach 8dB!

At 144MHz sky-noise limits the maximum usable sensitivity of a receiver used for terrestrial communications to about 2dB noise-figure. (This is about the same as 0.05uV for 10dB s+n/n ratio in ssb bandwidths.) Lower noise-figures are easily obtainable with modern devices, but they won't let you hear any more! However, there is a distinct advantage in using a very low noise preamp to improve the sensitivity of a transceiver - if it has been properly designed.

Overall (or system) noise figure depends not only on the noise figure of the preamplifier, but also on its gain and the noise figure of the subsequent stage (the transceiver in this case). By adjusting the gain of the preamplifier it is possible to set the system noise-figure to any value greater than that of the intrinsic noise figure of the preamplifier.

But, why bother to adjust the gain? It's an unfortunate fact that the more gain you put in front of a receiver, the more susceptible it becomes to overload effects. By putting just enough low noise gain ahead of the receiver to set the overall sensitivity to a level where external noise is the limiting factor an optimum (for the system) is reached. A very low noise preamplifier will minimise the amount of gain required, and hence the degradation of the dynamics.

CIRCUIT DESCRIPTION

A low loss nitrogen filled relay provides the antenna changeover function. This is followed by a BF981 in an input noise-matched, output conjugately-matched configuration for a very low noise-figure with optimum dynamic range. Following the output matching a variable attenuator provides the gain control without compromising the dynamic performance, which would be the case if the usual amateur practice of providing gain control by varying the bias on G_2 of the fet was followed.

After the attenuator, a properly designed bandpass filter provides very substantial rejection of out-of-band signals.

The preamplifier is designed and tested to very high standards. A plated-through hole epoxy fibreglass pcb is employed and bushed mountings are provided for

mounting in the FT290.

INSTALLATION

Before attempting installation of the SLNA 145sb it is very strongly recommended that the manual and circuit diagrams supplied by Yaesu are studied thoroughly. If you are at all unsure of your abilities muTek limited recommends that you find a competent technician to perform the installation; we cannot accept responsibility for damage caused by incorrect or unskilled installation.

If any difficulties are encountered please get in touch with muTek - we want to make sure that you are happy with our products. Telephone is usually the best medium. Likewise if you have any constructive comments please let us know. Thanks.

The preamplifier mounts on the lugs provided by Yaesu for installation of the tone encode/tone squelch assembly. With the bottom of the unit removed, these may be found close to the 'Switch B' unit (see p.33 of the manual)

- 1) Remove both top and bottom covers from the transceiver.
- 2) Remove the battery holder.
- 3) Locate and remove C101. This is probably best done by crushing the component with a pair of long-nosed pliers and then repeatedly bending the leads remaining until they break flush with the pcb.
- 4) Remove L02 (usually yellow-sleeved toroidal inductor).
- 5) Remove the telescopic antenna.
- 6) Remove the anodised aluminium trim from the antenna side of the case.
- 7) Remove the screws securing the antenna screening tube and carefully bend the assembly away, thus providing access to the space in which the preamplifier will be mounted.
- 8) Mount the SLNA 145sb using the screws provided.
- 9) Solder the screens of the red and blue coded cables to the earthed tag on the tag-strip mounted by the power amplifier compartment.
- 10) Solder the centre of the blue-coded cable to the stand-off in the pa compartment.
- 11) Solder the centre of the red-coded cable to the centre tag of the tag-strip.
- 12) Solder the centre of the white-coded cable to the input of T101 (see diag.)
- 13) Solder the screen of the white-coded cable to the adjacent ground area.
- 14) Solder the red wire to the 12V standoff.
- 15) Solder the orange wire to the 6.8V transmit standoff.
- 16) Replace the antenna screening tube.
- 17) Replace the anodised aluminium trim.
- 18) Replace the battery compartment. *Take care not to trap red lead.*
- 19) Turn the transceiver on and tune a weak fm signal. Adjust the attenuator on the preamplifier using the trimming tool provided until the slightest degradation in signal to noise ratio is noticed, then back-off this adjustment very slightly. This will result in the maximum dynamic range possible with the system.
- 20) Replace the top and bottom covers.
- 21) Installation is complete.

Location of white coded lead termination

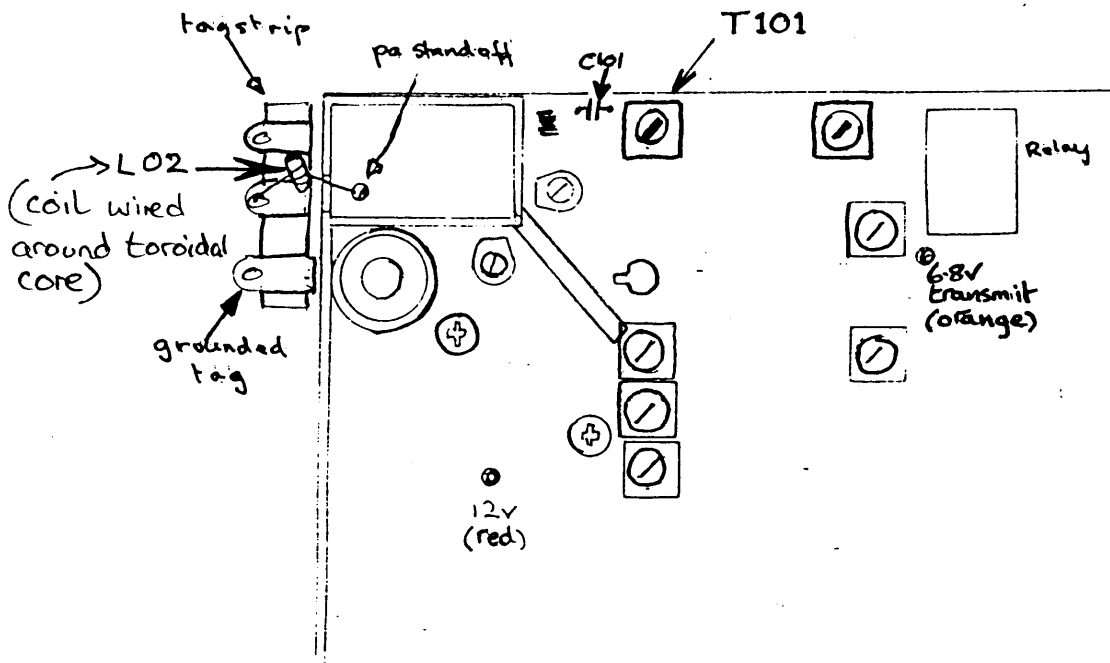
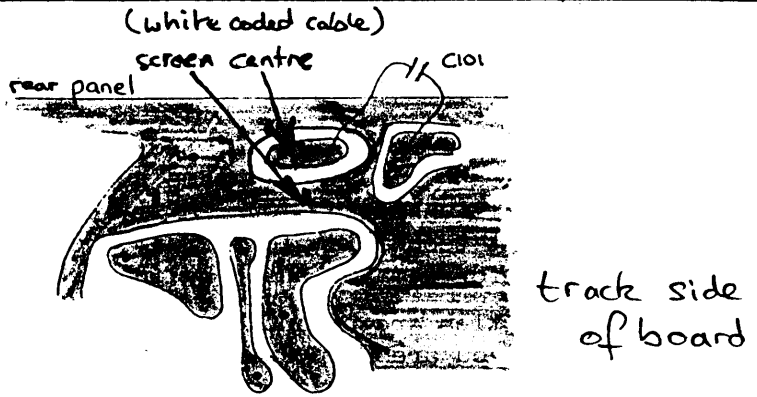

Location of major components

Circuit schematic SLNA 145sb

