

adaptec

# AHA-1540B/1542B

## *User's Manual*

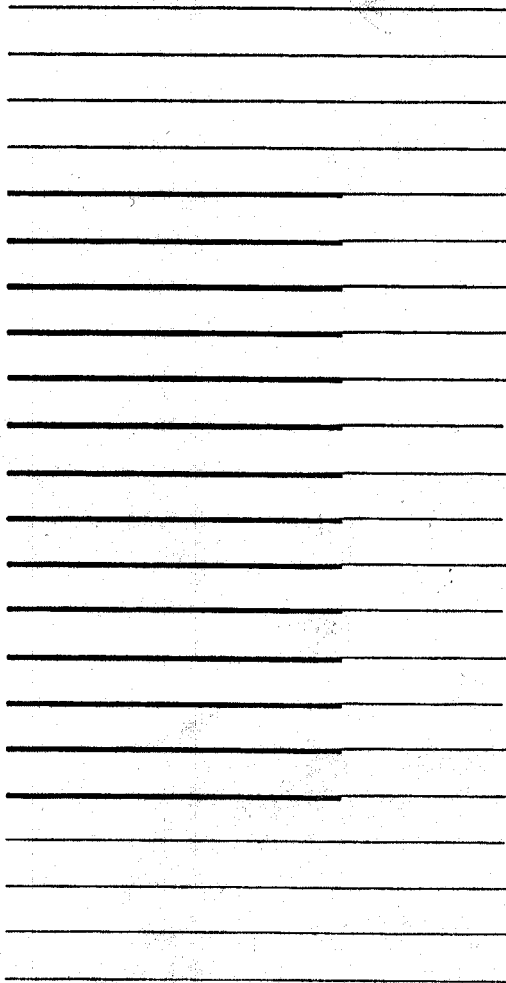

Rev 1.0 April 1990

## Section Two Preparation & Configuration

### 2.1 UNPACKING AND INSPECTION

The carrier is responsible for damage incurred during shipment. In case of damage, have the carrier note the damage on both the delivery receipt and the freight bill, then notify your freight company representative so that the necessary insurance claims can be initiated.

After opening the shipping container, use the packing slip to verify receipt of the individual items listed on the slip. Retain the shipping container and packing material for possible later reuse should return of the equipment to the factory be necessary.

*NOTE: The AHA-1540B/1542B, like all electronic equipment is static sensitive. Please take the proper precautions when handling the board. Keep the board in its conductive wrapping until it is configured and ready to be installed in your system.*

### 2.2 PREPARATION

The following section details the preparation procedure for the Adaptec AHA-1540B/1542B AT-to-SCSI host adapter. The preparation of the board consists of checking the various on-board jumpers, inserting the board into a full-length AT compatible connector, and connecting a SCSI cable from the on-board connector to a SCSI target.

The following diagram shows the approximate location of the various customer configurable items on the AHA-1540B/1542B. Listed after the diagram are the functions of each item.

Since the AHA-1540B/1542B is sensitive to static shock, it is recommended that the board is placed on the anti-static bag in which it came for examination and jumper configuration.

## Section Two Preparation and Configuration

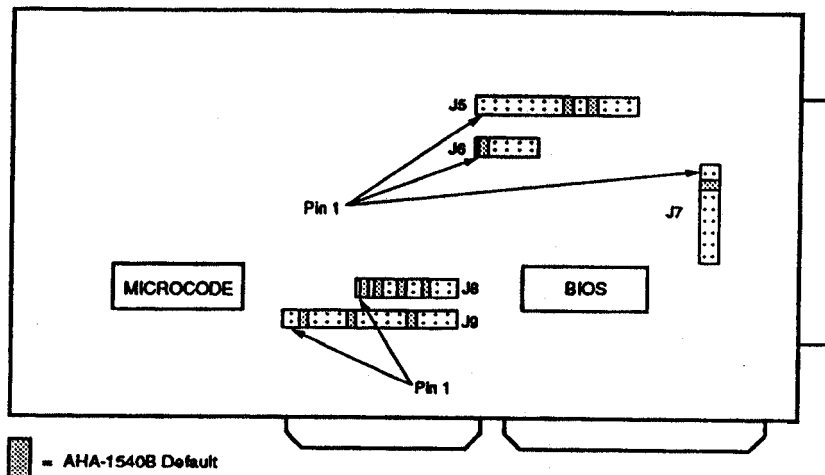

FIGURE 2-1. JUMPER LOCATIONS

### 2.3 JUMPER CONFIGURATION

All of the jumpers have been preset at the factory to ensure proper system operation with the majority of AT bus systems. This information is provided to help the OEM or system integrator configure the system properly if other option boards present conflicts or if more than one AHA-154X board will be installed in the same system.

## Section Two Preparation and Configuration

### 2.3.1 Jumper Block J5

Jumper block J5 is shown below:

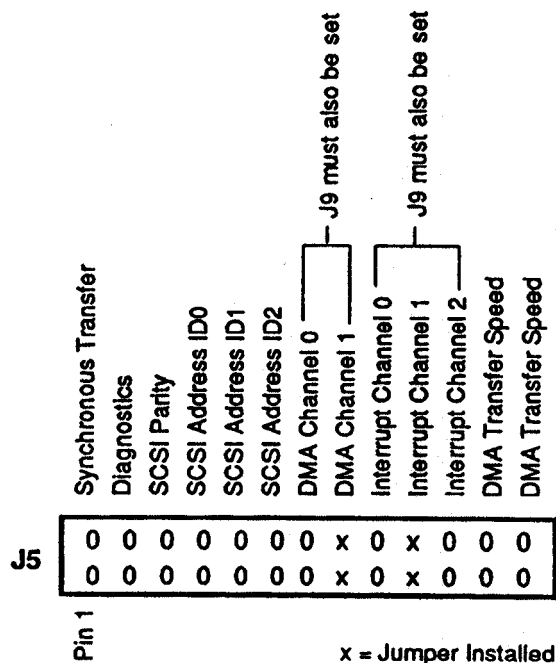

Jumper block J5 is the large horizontally-oriented block of jumpers located under the internal 50-pin connector J2. Pin pair 1 is the leftmost pair of pins.

#### 2.3.1.1 SCSI Synchronous Negotiation

Pin-pair 1 of jumper block J5 is the synchronous negotiation enable jumper. The AHA-1540B/1542B will initiate SCSI synchronous negotiation during initialization, or after a SCSI reset if this jumper is installed. If the jumper is not installed, the AHA-1540B/1542B will still support synchronous SCSI transfers, but a different SCSI device must initiate the negotiation. **Default is jumper removed, synchronous negotiation initiation disabled.** If any attached

## Section Two Preparation and Configuration

SCSI devices support synchronous transfer, the initiation of negotiation should be enabled by the AHA-154X or the attached synchronous device(s) to implement the synchronous data transfer speed on the SCSI bus.

### 2.3.1.2 Diagnostic Jumper

Pin-pair 2 of jumper block J5 is a factory diagnostic jumper. This jumper is reserved for Adaptec use and must not have a jumper shunt installed. If this jumper is installed, the firmware will loop through the power on diagnostics, preventing normal operation. Default is jumper removed.

### 2.3.1.3 SCSI Parity

Pin-pair 3 of jumper block J5 is the parity enable/disable jumper. The SCSI parity checking is disabled if this jumper is installed. The default is parity checking enabled, jumper removed.

### 2.3.1.4 SCSI Address

Pin-pairs 4, 5, and 6 of jumper block J5 define the SCSI address of the AHA-154XB. The SCSI address is selected according to the following table. The default address is 7 (no jumpers installed).

		SCSI ID bit 0	SCSI ID bit 1	SCSI ID bit 2	PIN-PAIR			SCSI ADDRESS
		4	5	6	4	5	6	
J5	Pin 1	0	0	0	0	0	0	7*
	Pin-pair 4	0	0	0	x	0	0	6
	Pin-Pair 5	0	0	0	0	x	0	5
	Pin-pair 6	0	0	0	x	x	0	4
		0	0	x	0	0	x	3
		x	0	x	x	0	x	2
		0	x	x	0	x	x	1
		x	x	x	x	x	x	0

x = Jumper Installed  
\* = Default

## **Section Two      Preparation and Configuration**

### **2.3.1.5 DMA Channel**

There are two jumper blocks involved in selecting the DMA channel. These are J5 and J9. The DMA channel selection jumpers consist of pin pairs 7 and 8 located in the large block of jumper pins J5. The DMA channel reported to the AT during the Return Configuration command is set by these jumpers according to the following table. Default is DMA channel 5.

Jumper set J9, pairs 1 through 4, selects the DMA REQ signal to be used by the AHA-1540B/1542B. This jumper set is located near the bottom center of the host adapter. Pin pair 1 is the leftmost pair of pins. Default is DMA Request 5.

Jumper set J9, pairs 5 through 8, selects the DMA ACK signal to be used by the AHA-1540B/1542B according to the following table. This jumper set is located near the bottom center of the host adapter. Pin pair 1 is the leftmost pair of pins. Default is DMA Acknowledge 5.

There are four DMA channels that may be chosen for use by the AHA-1540B/AHA-1542B, channels 0, 5, 6, and 7. The DMA channel is set up by using the jumper blocks and pin-pairs as previously described. The jumper settings for each channel are shown in the following diagrams:

## Section Two      Preparation and Configuration

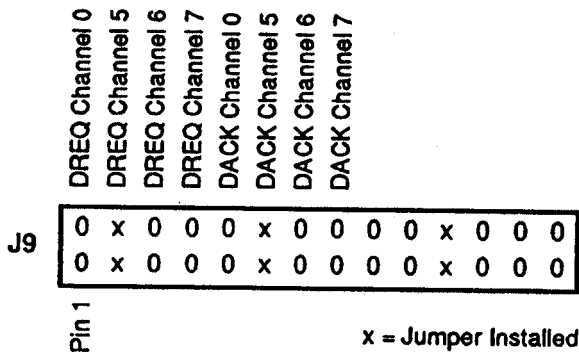
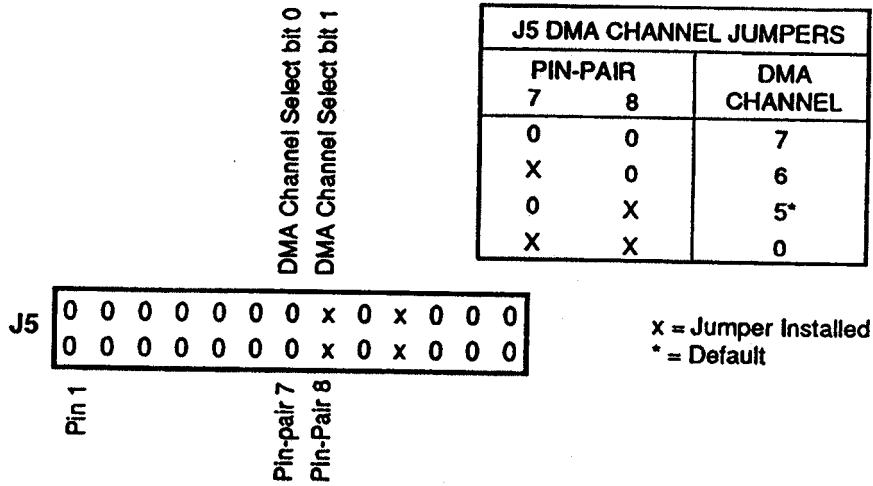

**DREQ 0, 5, 6, 7** — connects the DMA request line to the AT bus. One of these four lines must be connected in order for the board to function. The jumper installed must match the DMA channel setting in J5.

**DACK 0, 5, 6, 7** — connects the DMA acknowledge line to the AT bus. One of these four lines must be connected in order for the board to function. The jumper installed must match the DMA channel setting in J5.

## Section Two Preparation and Configuration

### 2.3.1.6 AT Interrupt Channel

There are two jumper blocks involved in selecting the AT interrupt channel. These are J5 and J9. The AT interrupt channel jumpers consist of pin pairs 9, 10, and 11 in the large block of jumper pin pairs J5. The interrupt channel reported to the AT during the Return Configuration Command is set by these jumpers according to the following table. The default is interrupt channel 11.

Jumper set J9 selects the AT interrupt channel to be used by the AHA-1540B/1542B. This jumper set is located near the bottom center of the host adapter. Pin pair 1 is the leftmost pair of pins. The interrupt channel used is set according to the following table. The default interrupt channel is 11.

		J5 INTERRUPT CHANNELS			
		PIN-PAIR			INTERRUPT CHANNEL
		9	10	11	
		0	0	0	9
		x	0	0	10
		0	x	0	11*
		x	x	0	12
		0	0	x	14
		x	0	x	15

J5														
Pin 1	0	0	0	0	0	0	0	0	0	0	x	0	0	0
	0	0	0	0	0	0	0	0	0	0	x	0	0	0

Interrupt Channel Select bit 0	Interrupt Channel Select bit 1	Interrupt Channel Select bit 2
Pin-pair 9	Pin-pair 10	Pin-pair 11

x = Jumper Installed  
\* = Default



## Section Two Preparation and Configuration

		IRQ Channel 9	IRQ Channel 10	IRQ Channel 11	IRQ Channel 12	IRQ Channel 14	IRQ Channel 15				
J9	Pin 1	0	x	0	0	0	x	0	0	0	0
		0	x	0	0	0	x	0	0	0	0

x = Jumper Installed

IRQ 9, 10, 11, 12, 14, 15 — connects the interrupt line to the AT bus. One of these jumpers must be installed in order for the AHA-154XB to interrupt the Host. The jumper selected must match the interrupt channel setting in J5.

### 2.3.1.7 DMA Transfer Speed Default

Pin-pairs 12 and 13 of jumper block J5 set the default DMA transfer speed. Installing jumper shunts as shown below will set any of four default DMA transfer speeds. (See Appendix A for system timing requirements.) The default speed is selected after power on or after a hard reset occurs. This speed may also be tuned to allow for the fastest possible transfer (minimum bus on time) for any particular system by using the Host Adapter command Set Transfer Speed. The Host Adapter command overrides the jumper settings. The default is no jumper installed.

## Section Two Preparation and Configuration

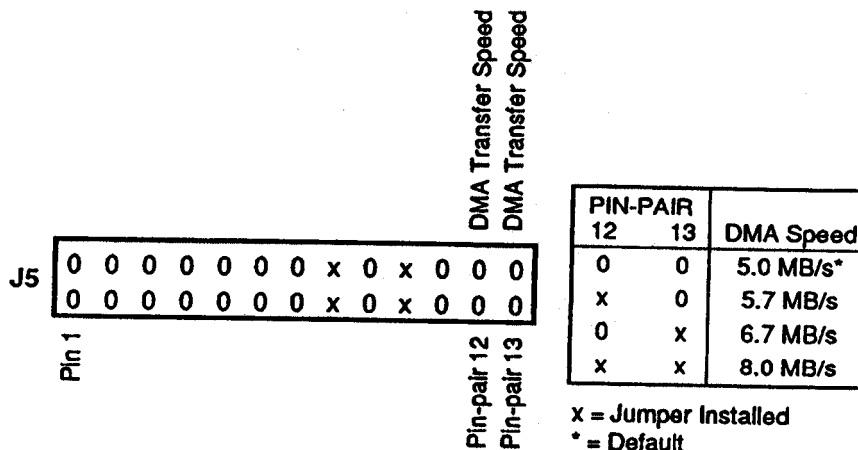

### 2.3.2 Jumper Block J6

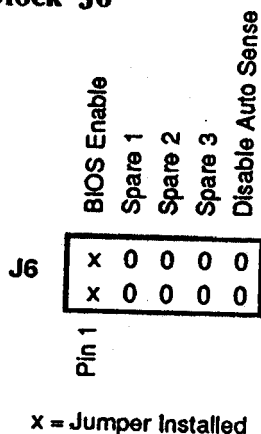

**BIOS Enable** — when installed, enables the BIOS Prom to be read.

**Disable Auto Sense** — when installed, the AHA-1540B will not automatically issue a Request Sense Command when a check condition is received from the SCSI target. Unless the user is debugging a driver that they wrote, it is best to leave this jumper removed. Default is jumper removed, Auto Sense enabled.

## Section Two Preparation and Configuration

### 2.3.3 Jumper Block J7

Jumper block J7 is located near the external SCSI connector and is shown below:

J7		
Pin 1	0 0	Floppy Secondary Address
	x x	Port Address Select bit 0
	0 0	Port Address Select bit 1
	0 0	Port Address Select bit 2
	0 0	Wait State bit 0
	0 0	Wait State bit 1
	0 0	BIOS Address Select bit 0
	0 0	BIOS Address Select bit 1

x = Jumper Installed

Pin pair 1 is the topmost pair of pins

#### 2.3.3.1 Floppy Secondary Address

When a jumper is installed in pin pair 1 of J7, the floppy disk controller (AHA-1542B) will respond to the secondary I/O port addresses 170 through 177 (hex). The default is jumper removed; floppy controller responds to the standard AT I/O port addresses of 1F0 through 1F7 (hex).

#### 2.3.3.2 Board I/O Port Address Select

The starting address of the block of four I/O ports required by the AHA-1540B/1542B is selected by the jumpers in jumper block J7. Pin pair 1 is the topmost pair of pins. The default address is 330 (hex). That port address is required by the BIOS. Other valid port addresses are 334H, 230H, 234H, 134H, and 130, 334, 230, 234, 130, and 134 (hex). These port addresses may be used by device drivers and operating systems that support multiple host adapters. The default address is 330 (hex).

## Section Two Preparation and Configuration

J7		AT PORT ADDRESS				
Pin pair 2	0 0	Port Address Select bit 0	Bit 2	Bit 1	Bit 0	Select bit 1
Pin pair 3	x x	Port Address Select bit 1	A9	A8	A2	ADDRESS
Pin pair 4	0 0	Port Address Select bit 2	4	3	2	Pin Pair
	0 0		0	0	0	334H
	0 0		0	0	x	330H*
	0 0		0	x	0	234H
	0 0		0	x	x	230H
	0 0		x	0	0	134H
	0 0		x	0	x	130H
	0 0		x	x	0	not used
	0 0		x	x	x	not used

x = Jumper Installed  
\* = Default

Note that selection of an I/O Port address other than 330H requires that the on-board BIOS be disabled to work correctly, and a driver which can work with that address. The on-board BIOS cannot be used with a port address other than 330H.

### 2.3.3.3 Board BIOS Wait State Select

Pin pairs 5 and 6 on J7 allow the signal IOCHRDY to be driven inactive on the bus during BIOS reads. The time may be set to a wait state value of 100, 200, or 300 nsec. Default is Wait State Disabled.

J7		WS 0	WS 1	DELAY (ns)
Pin 1	0 0	-	-	0 (IOCHRDY not driven)*
	x x	x	-	100
	0 0	-	x	200
	0 0	x	x	300

x = Jumper Installed  
- = Jumper Not Installed  
\* = Default

## Section Two Preparation and Configuration

### 2.3.3.4 Board BIOS Base Address Select

The starting address of the address space reserved for the on-board BIOS is selected by pin pairs 7 and 8 on J7.

J7		BIOS SEL 0	BIOS SEL 1	ADDRESS
Pin 1	0 0	-	-	DC000*
	x x	x	-	CC000
	0 0	-	x	D8000
	0 0	x	x	C8000

BIOS Address Select bit 0  
 BIOS Address Select bit 1

x = Jumper Installed  
 - = No Jumper Installed  
 \* = Default

### 2.3.3.5 Jumper Block J8 (AHA-1542B only)

Jumper Block J8 is located at the lower center of the board above J9. It is used to configure the on-board floppy disk controller and is not present in the 1540B.

J8		Floppy Enable	DREQ 2	DREQ 3	DACK 2	DACK 3	IRQ 6	IRQ 10	Dual Channel Speed
Pin 1	x x	0	x	0	x	0	0	0	
	x x	0	x	0	x	0	0	0	

x = Jumper Installed

## Section Two Preparation and Configuration

**Floppy Enable** — when installed, enables the floppy to respond to I/O writes and reads. **Default is jumper installed, floppy enabled.** If there is another floppy controller in the system, the floppy controller on the AHA-1542B can be disabled by removing this jumper.

**DREQ 2,3** — selects either DREQ 2 or 3 for floppy controller. At least one jumper must be installed for operation, and the corresponding DACK jumper must also be installed. **Default is jumper in Pin Pair position 2, DREQ 2.**

**DACK 2,3** — selects either DACK 2 or 3 for floppy controller. At least one jumper must be installed for operation, and the corresponding DREQ jumper must also be installed. **Default is jumper in Pin Pair position 4, DACK 2.**

**IRQ 6,10** — selects either interrupt channel 6 or interrupt channel 10. At least one must be selected for proper operation. **Default is jumper in Pin Pair position 6, Interrupt Channel 6.**

**Dual Speed** — this jumper should be installed when a floppy drive with a dual speed spindle is used. For normal operation this jumper should not be installed.

### 2.3.4 SCSI Terminators

RN2, RN3, and RN5 are the SCSI terminators. If both an internal and an external SCSI cable is used, then the farthest end of both the internal and the external cable should be terminated (either by terminators on a SCSI device or by passive terminators attached to the cable); all three terminators on the AHA-1540B/1542B must be removed.

If an internal or an external cable is used (but not both) then the farthest end of that cable should be terminated and the terminators should remain installed on the AHA-1540B/1542B. **Default is terminators installed.**

## **Section Two      Preparation and Configuration**

### **2.3.5 SCSI Terminator Power**

Fuse, F1, controls the terminator power. If another SCSI device is supplying terminator power, then F1 may optionally be removed. No more than five SCSI devices should be configured to supply terminator power to a single SCSI bus. Default is F1 installed with the AHA-1540B/1542B supplying the terminator power.