

**Typical Applications**

- Digital Communications Systems
- Spread Spectrum Communication Systems
- GSM, DCS 1800, JDC, D-AMPS Systems
- Commercial and Consumer Systems
- GMSK, QPSK, DQPSK, QAM Modulation

**Product Description**

The RF2422 is a monolithic integrated quadrature modulator IC capable of universal direct modulation for high-frequency AM, PM, or compound carriers. This low-cost IC implements differential amplifiers for the modulation inputs, 90° carrier phase shift network, carrier limiting amplifiers, two matched double-balanced mixers, summing amplifier, and an output RF amplifier which will drive 50Ω from 800MHz to 2500MHz. Component matching, which can only be accomplished with monolithic construction, is used to full advantage to obtain excellent amplitude balance and phase accuracy.

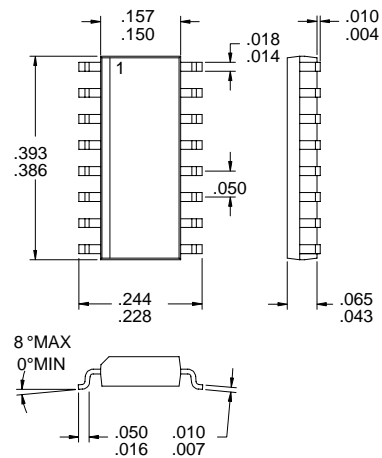

**Optimum Technology Matching® Applied**

- Si BJT       GaAs HBT       GaAs MESFET  
 Si Bi-CMOS

**Package Style: SOP-16**

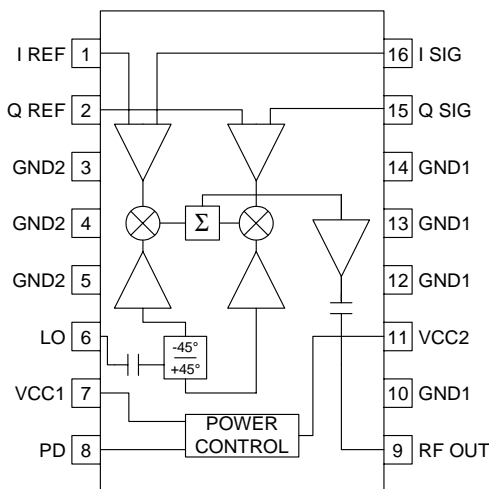

**Functional Block Diagram**

**Features**

- Single 5V Power Supply
- Integrated RF Quadrature Network
- No Tuning Required
- Low LO Input Level
- Digitally Controlled Power Down Mode
- 800MHz to 2500MHz Operation

**Ordering Information**

- RF2422      2.5GHz Direct Quadrature Modulator  
 RF2422 PCBA      Fully Assembled Evaluation Board

RF Micro Devices, Inc.  
7625 Thorndike Road  
Greensboro, NC 27409, USA

Tel (336) 664 1233  
Fax (336) 664 0454  
<http://www.rfmd.com>

## Absolute Maximum Ratings

Parameter	Rating	Unit
Supply Voltage	-0.5 to +7.5	V <sub>DC</sub>
Input LO and RF Levels	+10	dBm
Operating Ambient Temperature	-40 to +85	°C
Storage Temperature	-40 to +150	°C



**Caution!** ESD sensitive device.

RF Micro Devices believes the furnished information is correct and accurate at the time of this printing. However, RF Micro Devices reserves the right to make changes to its products without notice. RF Micro Devices does not assume responsibility for the use of the described product(s).

Parameter	Specification			Unit	Condition
	Min.	Typ.	Max.		
<b>Carrier Input</b>					T=25 °C, V <sub>CC</sub> =5V
Frequency Range		800 to 2500		MHz	
Power Level		-6 to +6		dBm	
Input VSWR		5:1			At 900MHz
Input VSWR		1.8:1			At 1800MHz
Input VSWR		1.2:1			At 2500MHz
<b>Modulation Input</b>					
Frequency Range		DC to 250		MHz	
Reference Voltage (V <sub>REF</sub> )		3.0		V	
Maximum Modulation (I&Q)			V <sub>REF</sub> ±1.0	V	
Gain Asymmetry		0.2		dB	
Quadrature Phase Error		3		°	
Input Resistance		30		kΩ	
Input Bias Current			40	μA	
<b>RF Output</b>					LO=2GHz and -5dBm, I&Q=2.0V <sub>pp</sub> , SSB
Output Power	-3		+3	dBm	
Output Impedance		50		Ω	
Output VSWR		3.5:1			At 900MHz
Output VSWR		1.3:1			At 2000MHz
Output VSWR		1.15:1			At 2500MHz
Harmonic Output	-30	-35		dBc	
Broadband Noise Floor		-135		dBm/Hz	
Sideband Suppression	25	35		dB	
Carrier Suppression	30	35		dB	
IM <sub>3</sub> Suppression	30	35		dB	Intermodulation of the carrier and the desired RF signal
IM <sub>3</sub> Suppression	25	30		dB	Intermodulation of baseband signals
<b>Power Down</b>					
Turn On/Off Time		<100		ns	
PD Input Resistance		>50		kΩ	
Power Control "ON"			2.8	V	Threshold voltage
Power Control "OFF"	1.0	1.2		V	Threshold voltage
<b>Power Supply</b>					
Voltage		5		V	Specifications
		4.5 to 6.0		V	Operating Limits
Current		45	50	mA	Operating
			25	μA	Power Down

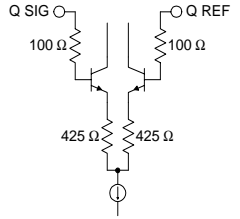
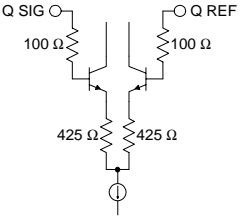
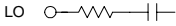
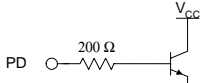
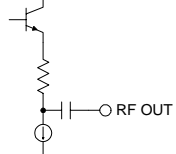
Pin	Function	Description	Interface Schematic
1	I REF	Reference voltage for the I mixer. This voltage should be the same as the DC voltage supplied to the I SIG pin. A voltage of 3.0V is recommended. The SIG and REF inputs are inputs of a differential amplifier. Therefore the REF and SIG inputs are interchangeable. If swapping the I SIG and I REF pins, the Q SIG and Q REF also need to be swapped to maintain the correct phase. It is also possible to drive the SIG and REF inputs in a balanced mode. This will increase the gain.	
2	Q REF	Reference voltage for the Q mixer. This voltage should be the same as the DC voltage supplied to the Q SIG pin. A voltage of 3.0V is recommended.	
3	GND2	Ground connection of the LO phase shift network. This pin should be connected directly to the ground plane.	
4	GND2	Same as pin 3.	
5	GND2	Same as pin 3.	
6	LO	The input of the phase shifting network. This pin has an internal DC blocking capacitor. At frequencies higher than 2GHz this port is well-matched to 50Ω. This port is voltage driven so matching at lower frequencies is not required.	
7	VCC1	Power supply for all circuits except the RF output stage. An external capacitor is needed if no other low frequency bypass capacitor is nearby.	
8	PD	Power Down control. When this pin is "low", all circuits are shut off. A "low" is typically 1.2V or less at room temperature. When this pin is "high" (V <sub>CC</sub> ), all circuits are operating normally. If PD is below V <sub>CC</sub> , output power and performance will be degraded. Operating in this region is not recommended, although it might be useful in some applications where power control is required.	
9	RF OUT	This is the 50Ω RF Output. This pin has an internal DC blocking capacitor. At frequencies higher than 2GHz this port is well-matched. Typical impedances at lower frequencies are: 24-j30 Ω @ 1GHz, 27-j10 Ω @ 1.4GHz, 31-j3 Ω @ 1.8GHz. At those frequencies, external matching may be needed to optimize output power.	
10	GND3	Ground connection for the RF output stage. This pin should be connected directly to the ground plane.	
11	VCC2	Power supply for the RF Output amplifier. An external capacitor is needed if no other low frequency bypass capacitor is near by.	
12	GND1	Ground connection for the LO and baseband amplifiers, and for the mixers. This pin should be connected directly to the ground plane.	
13	GND1	Same as pin 12.	
14	GND1	Same as pin 12.	
15	Q SIG	Baseband input to the Q mixer. This pin is DC coupled. Maximum output power is obtained when the input signal has a peak to peak amplitude of 2V. The recommended DC level for this pin is 3.0V. The peak minimum voltage on this pin (V <sub>REF</sub> - peak modulation amplitude) should never drop below 2.0V. The peak maximum voltage on this pin (V <sub>REF</sub> + peak modulation amplitude) should never exceed 4.0V.	See pin 2.

16	<b>I SIG</b>	Baseband input to the I mixer. This pin is DC coupled. Maximum output power is obtained when the input signal has a peak to peak amplitude of 2V. The recommended DC level for this pin is 3.0V. The peak minimum voltage on this pin ( $V_{REF} - \text{peak modulation amplitude}$ ) should never drop below 2.0V. The peak maximum voltage on this pin ( $V_{REF} + \text{peak modulation amplitude}$ ) should never exceed 4.0V.	See pin 1.
----	--------------	--	------------

## Application Schematic AC Coupled

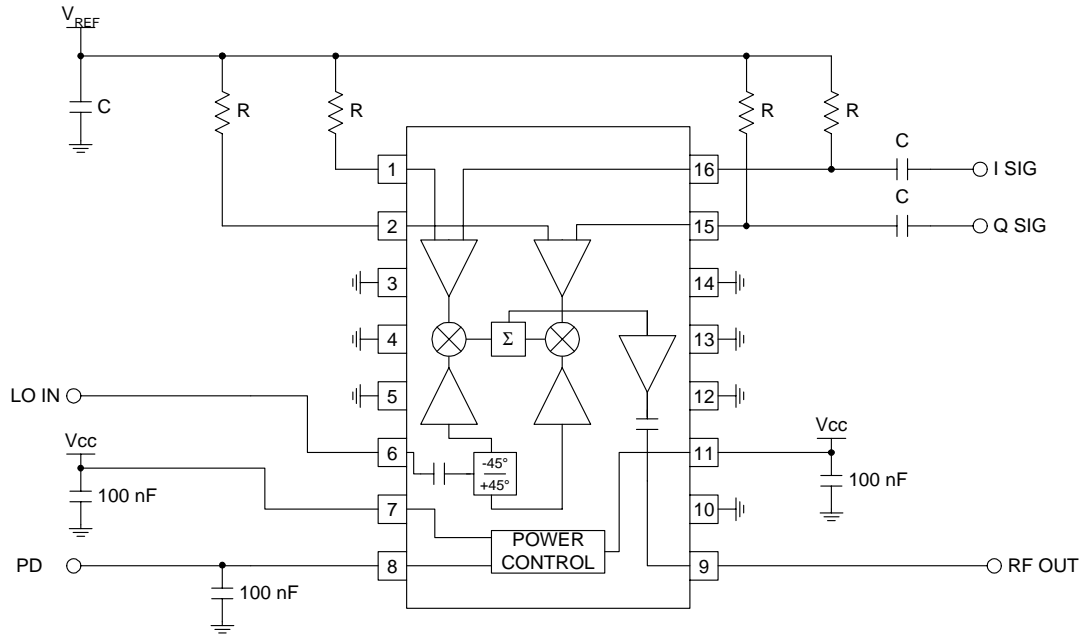

NOTE: The values of R and C depend on the minimum baseband frequency. I.e., the cutoff frequency of this high pass filter should be lower than the lowest frequency component in the I/Q spectrum.

## Application Schematic DC Coupled

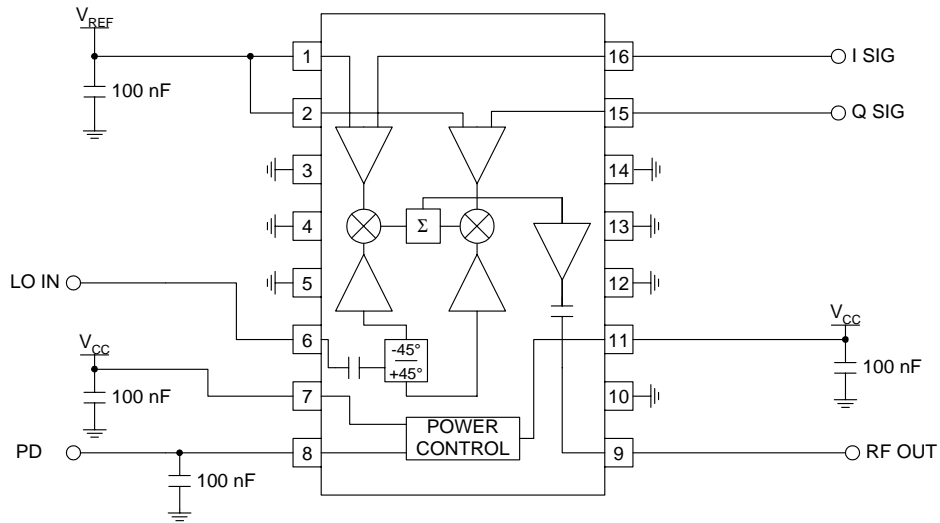

## Evaluation Board Schematic 1.5" x 1.5"

(Download Bill of Materials from [www.rfmd.com](http://www.rfmd.com).)

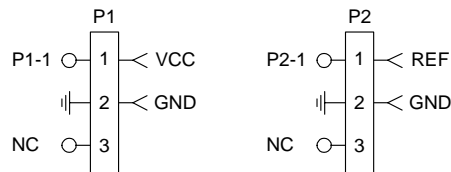

2422400 Rev A

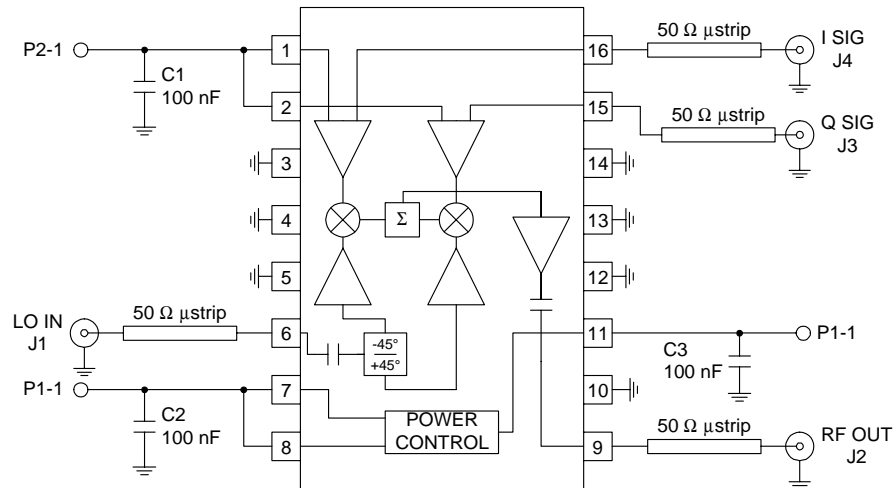

## Evaluation Board Layout

