

74ACT11657

OCTAL TRANSCEIVER WITH PARITY GENERATOR/CHECKER AND 3-STATE OUTPUTS

SCAS232 – AUGUST 1992 – REVISED APRIL 1993

- Inputs Are TTL-Voltage Compatible
- Flow-Through Architecture Optimizes PCB Layout
- Center-Pin V_{CC} and GND Pin Configurations Minimize High-Speed Switching Noise
- EPIC™ (Enhanced-Performance Implanted CMOS) 1- μ m Process
- 500-mA Typical Latch-Up Immunity at 125°C
- Package Options Include Plastic Small-Outline Packages and Standard Plastic 300-mil DIPs

description

The 74ACT11657 contains eight noninverting buffers with 3-state outputs and an 8-bit parity generator/checker and is intended for bus-oriented applications.

The transmit/receive (T/\bar{R}) input determines the direction of data flow through the bidirectional transceivers. When T/\bar{R} is high, data flows from the A port to the B port (transmit mode); when T/\bar{R} is low, data flows from the B port to the A port (receive mode). When the output-enable (\overline{OE}) input is high, both the A and B ports are in the high-impedance state.

Odd or even parity is selected by a logic high or low level, respectively, on the ODD/\overline{EVEN} input. PARITY carries the parity bit value; it is an output from the parity generator/checker in the transmit mode and an input to the parity generator/checker in the receive mode.

In the transmit mode, after the A bus is polled to determine the number of high bits, PARITY is set to the logic level that maintains the parity sense selected by the level at the ODD/\overline{EVEN} input. For example, if ODD/\overline{EVEN} is low (even parity selected) and there are five high bits on the A bus, then PARITY is set to the logic high level so that an even number of the nine total bits (eight A-bus bits plus parity bit) are high.

In the receive mode, after the B bus is polled to determine the number of high bits, the \overline{ERR} output logic level indicates whether or not the data to be received exhibits the correct parity sense. For example, if ODD/\overline{EVEN} is high (odd parity selected), PARITY is high, and there are three high bits on the B bus, then \overline{ERR} is low, indicating a parity error.

The 74ACT11657 is characterized for operation from -40°C to 85°C .

DW PACKAGE
(TOP VIEW)

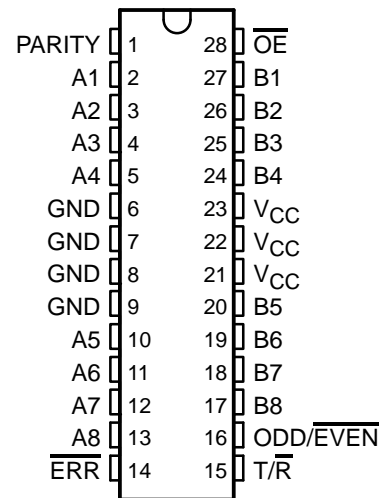

EPIC is a trademark of Texas Instruments Incorporated.

PRODUCTION DATA information is current as of publication date. Products conform to specifications per the terms of Texas Instruments standard warranty. Production processing does not necessarily include testing of all parameters.



POST OFFICE BOX 655303 • DALLAS, TEXAS 75265

Copyright © 1993, Texas Instruments Incorporated

74ACT11657
OCTAL TRANSCEIVER WITH PARITY GENERATOR/CHECKER
AND 3-STATE OUTPUTS

SCAS232 – AUGUST 1992 – REVISED APRIL 1993

FUNCTION TABLE

NUMBER OF A OR B INPUTS THAT ARE HIGH	INPUTS			INPUT/OUTPUT PARITY	OUTPUTS	
	\overline{OE}	T/R	ODD/EVEN		\overline{ERR}	OUTPUT MODE
0, 2, 4, 6, 8	L	H	H	H	Z	Transmit
	L	H	L	L	Z	Transmit
	L	L	H	H	H	Receive
	L	L	H	L	L	Receive
	L	L	L	H	L	Receive
	L	L	L	L	H	Receive
1, 3, 5, 7	L	H	H	L	Z	Transmit
	L	H	L	H	Z	Transmit
	L	L	H	H	L	Receive
	L	L	H	L	H	Receive
	L	L	L	H	H	Receive
	L	L	L	L	L	Receive
Don't care	H	X	X	Z	Z	Z

logic symbol†

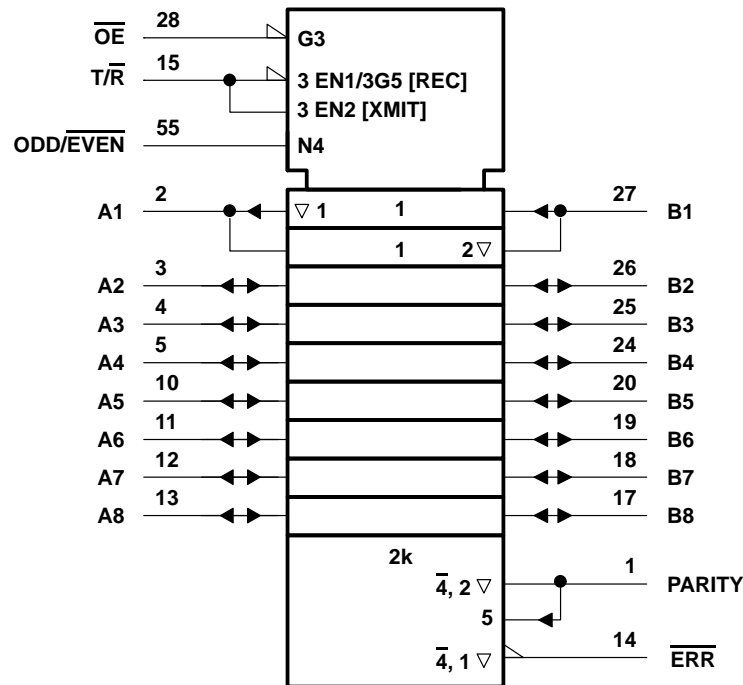

† This symbol is in accordance with ANSI/IEEE Std 91-1984 and IEC Publication 617-12.

74ACT11657
OCTAL TRANSCEIVER WITH PARITY GENERATOR/CHECKER
AND 3-STATE OUTPUTS

SCAS232 - AUGUST 1992 - REVISED APRIL 1993

logic diagram (positive logic)

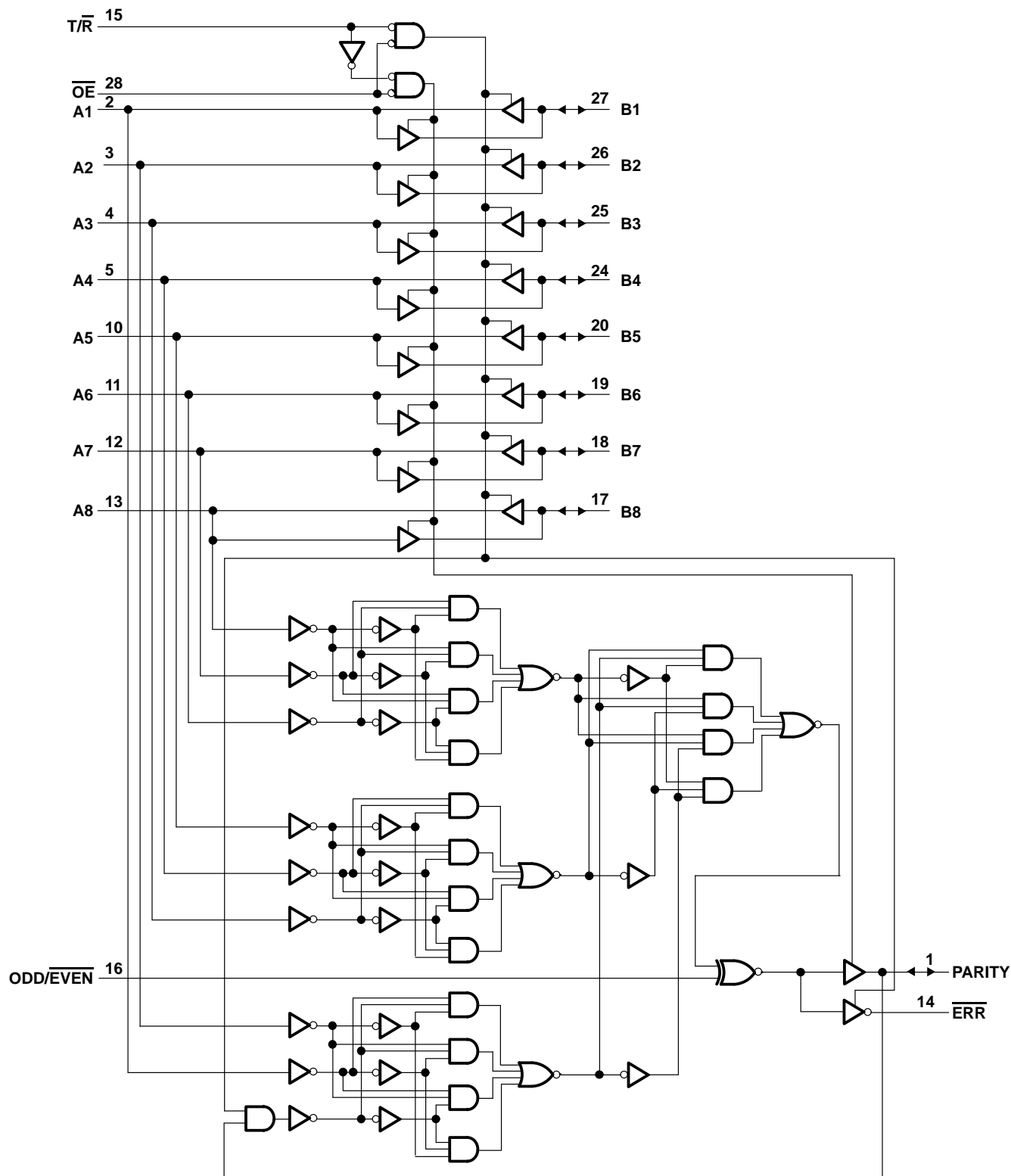

OCTAL TRANSCEIVER WITH PARITY GENERATOR/CHECKER AND 3-STATE OUTPUTS

SCAS232 – AUGUST 1992 – REVISED APRIL 1993

absolute maximum ratings over operating free-air temperature range (unless otherwise noted)†

Supply voltage range, V_{CC}	–0.5 V to 7 V
Input voltage range, V_I (see Note 1)	–0.5 V to $V_{CC} + 0.5$ V
Output voltage range, V_O (see Note 1)	–0.5 V to $V_{CC} + 0.5$ V
Input clamp current, I_{IK} ($V_I < 0$ or $V_I > V_{CC}$)	±20 mA
Output clamp current, I_{OK} ($V_O < 0$ or $V_O > V_{CC}$)	±50 mA
Continuous output current, I_O ($V_O = 0$ to V_{CC})	±50 mA
Continuous current through V_{CC} or GND	±225 mA
Storage temperature range	–65°C to 150°C

† Stresses beyond those listed under “absolute maximum ratings” may cause permanent damage to the device. These are stress ratings only, and functional operation of the device at these or any other conditions beyond those indicated under “recommended operating conditions” is not implied. Exposure to absolute-maximum-rated conditions for extended periods may affect device reliability.

NOTE 1: The input and output voltage ratings may be exceeded if the input and output clamp-current ratings are observed.

recommended operating conditions (see Note 2)

	MIN	NOM	MAX	UNIT
V_{CC} Supply voltage	4.5	5	5.5	V
V_{IH} High-level input voltage	2			V
V_{IL} Low-level input voltage			0.8	V
V_I Input voltage	0		V_{CC}	V
V_O Output voltage	0		V_{CC}	V
I_{OH} High-level output current			–24	mA
I_{OL} Low-level output current			24	mA
$\Delta t/\Delta v$ Input transition rise or fall rate	0		10	ns/V
T_A Operating free-air temperature	–40		85	°C

NOTE 2: Unused or floating pins (input or I/O) must be held high or low.

74ACT11657
**OCTAL TRANSCEIVER WITH PARITY GENERATOR/CHECKER
AND 3-STATE OUTPUTS**

SCAS232 – AUGUST 1992 – REVISED APRIL 1993

electrical characteristics over recommended operating free-air temperature range (unless otherwise noted)

PARAMETER	TEST CONDITIONS	V _{CC}	T _A = 25°C			MIN	MAX	UNIT	
			MIN	TYP	MAX				
V _{OH}	I _{OH} = - 50 μA	4.5 V	4.4			4.4		V	
		5.5 V	5.4			5.4			
	I _{OH} = - 24 mA	4.5 V	3.94			3.8			
		5.5 V	4.94			4.8			
I _{OH} = - 75 mA†	5.5 V				3.85				
V _{OL}	I _{OL} = 50 μA	4.5 V				0.1		V	
		5.5 V				0.1			
	I _{OL} = 24 mA	4.5 V				0.36			
		5.5 V				0.36			
I _{OL} = 75 mA†	5.5 V				1.65				
I _I	A or B ports	V _I = V _{CC} or GND	5.5 V	±0.1			±1		μA
I _{OZ} ‡	Control Inputs	V _O = V _{CC} or GND	5.5 V	±0.5			±5		μA
I _{CC}		V _I = V _{CC} or GND, I _O = 0	5.5 V	8			80		μA
ΔI _{CC} §		One input at 3.4 V, Other inputs at V _{CC} or GND	5.5 V	0.9			1		mA
C _i	Control inputs	V _I = V _{CC} or GND	5 V	4.5					pF
C _o	PARITY/ $\overline{\text{ERR}}$	V _O = V _{CC} or GND	5 V	10					pF
C _{io}	A or B ports	V _O = V _{CC} or GND	5 V	12					pF

† Not more than one output should be tested at a time, and the duration of the test should not exceed 10 ms.

‡ For I/O ports, the parameter I_{OZ} includes the input leakage current.

§ This is the increase in supply current for each input that is at one of the specified TTL voltage levels rather than 0 V or V_{CC}.

**switching characteristics over recommended operating free-air temperature range,
V_{CC} = 5 V ± 0.5 V (unless otherwise noted) (see Figure 1)**

PARAMETER	FROM (INPUT)	TO (OUTPUT)	T _A = 25°C			MIN	MAX	UNIT
			MIN	TYP	MAX			
t _{PLH}	A or B	B or A	2.9	6.7	8.4	2.9	9.4	ns
t _{PHL}			2.2	7	8.4	2.2	9.4	
t _{PLH}	A	PARITY	3.4	10.4	12.7	3.4	14.4	ns
t _{PHL}			3.9	10.9	13.2	3.9	15	
t _{PLH}	ODD/ $\overline{\text{EVEN}}$	PARITY, $\overline{\text{ERR}}$	2.5	7.9	9.4	2.5	10.7	ns
t _{PHL}			3	8.5	10	3	11.3	
t _{PLH}	B	$\overline{\text{ERR}}$	4.6	18.1	20.6	4.6	23.6	ns
t _{PHL}			4.9	18.5	21.8	4.9	24.6	
t _{PLH}	PARITY	$\overline{\text{ERR}}$	4	10.9	12.8	4	14.6	ns
t _{PHL}			3.9	11	12.9	3.9	14.7	
t _{PZH}	$\overline{\text{OE}}$	A, B, PARITY, or $\overline{\text{ERR}}$	2.6	9.1	10.8	2.6	12.1	ns
t _{PZL}			3.1	10.6	12.3	3.1	13.8	
t _{PHZ}	$\overline{\text{OE}}$	A, B, PARITY, or $\overline{\text{ERR}}$	4.5	9.1	10.8	4.5	12.1	ns
t _{PLZ}			4.5	8.7	10.5	4.5	11.6	

74ACT11657
OCTAL TRANSCEIVER WITH PARITY GENERATOR/CHECKER
AND 3-STATE OUTPUTS

SCAS232 – AUGUST 1992 – REVISED APRIL 1993

operating characteristics, $V_{CC} = 5\text{ V}$, $T_A = 25^\circ\text{C}$

PARAMETER		TEST CONDITIONS	TYP	UNIT
C_{pd}	Power dissipation capacitance per transceiver	Outputs enabled	95	pF
		Outputs disabled	21	

PARAMETER MEASUREMENT INFORMATION

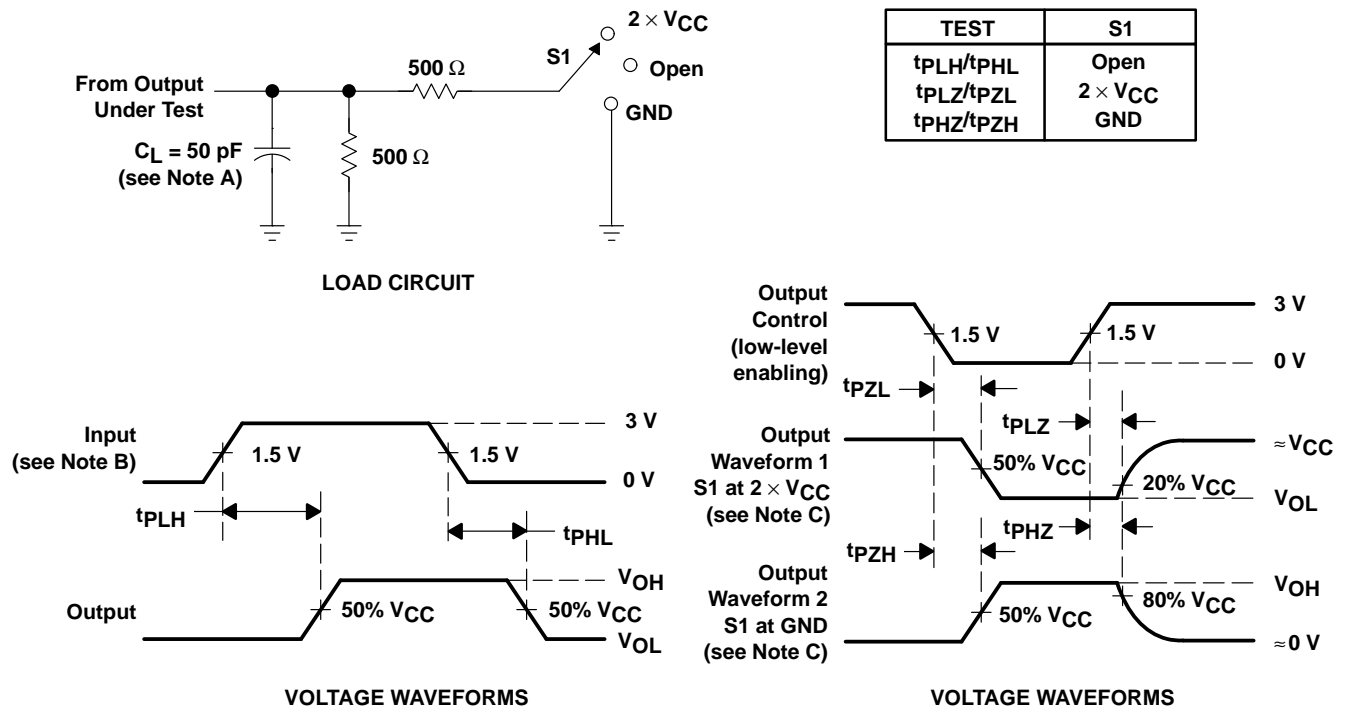

- NOTES: A. C_L includes probe and jig capacitance.
 B. All input pulses are supplied by generators having the following characteristics: $PRR \leq 10\text{ MHz}$, $Z_O = 50\ \Omega$, $t_r = 3\text{ ns}$, $t_f = 3\text{ ns}$.
 C. Waveform 1 is for an output with internal conditions such that the output is low except when disabled by the output control. Waveform 2 is for an output with internal conditions such that the output is high except when disabled by the output control.
 D. The outputs are measured one at a time with one input transition per measurement.

Figure 1. Load Circuit and Voltage Waveforms

IMPORTANT NOTICE

Texas Instruments (TI) reserves the right to make changes to its products or to discontinue any semiconductor product or service without notice, and advises its customers to obtain the latest version of relevant information to verify, before placing orders, that the information being relied on is current.

TI warrants performance of its semiconductor products and related software to the specifications applicable at the time of sale in accordance with TI's standard warranty. Testing and other quality control techniques are utilized to the extent TI deems necessary to support this warranty. Specific testing of all parameters of each device is not necessarily performed, except those mandated by government requirements.

Certain applications using semiconductor products may involve potential risks of death, personal injury, or severe property or environmental damage ("Critical Applications").

TI SEMICONDUCTOR PRODUCTS ARE NOT DESIGNED, INTENDED, AUTHORIZED, OR WARRANTED TO BE SUITABLE FOR USE IN LIFE-SUPPORT APPLICATIONS, DEVICES OR SYSTEMS OR OTHER CRITICAL APPLICATIONS.

Inclusion of TI products in such applications is understood to be fully at the risk of the customer. Use of TI products in such applications requires the written approval of an appropriate TI officer. Questions concerning potential risk applications should be directed to TI through a local SC sales office.

In order to minimize risks associated with the customer's applications, adequate design and operating safeguards should be provided by the customer to minimize inherent or procedural hazards.

TI assumes no liability for applications assistance, customer product design, software performance, or infringement of patents or services described herein. Nor does TI warrant or represent that any license, either express or implied, is granted under any patent right, copyright, mask work right, or other intellectual property right of TI covering or relating to any combination, machine, or process in which such semiconductor products or services might be or are used.