

SN65LBC180, SN75LBC180

LOW-POWER DIFFERENTIAL LINE DRIVER AND RECEIVER PAIRS

SLLS174A – FEBRUARY 1994 – REVISED MAY 1995

- **Designed for High-Speed Multipoint Data Transmission Over Long Cables**
- **Operate With Pulse Durations as Low as 30 ns**
- **Low Supply Current . . . 5 mA Max**
- **Meet or Exceed the Requirements of ANSI Standard RS-485 and ISO 8482:1987(E)**
- **3-State Outputs for Party-Line Buses**
- **Common-Mode Voltage Range of -7 V to 12 V**
- **Thermal Shutdown Protection Prevents Driver Damage From Bus Contention**
- **Positive and Negative Output Current Limiting**
- **Pin Compatible With the SN75ALS180**

description

The SN65LBC180 and SN75LBC180 differential driver and receiver pairs are monolithic integrated circuits designed for bidirectional data communication over long cables that take on the characteristics of transmission lines. They are balanced, or differential, voltage mode devices that meet or exceed the requirements of industry standards ANSI RS-485 and ISO 8482:1987(E). Both devices are designed using TI's proprietary LinBiCMOS™ with the low power consumption of CMOS and the precision and robustness of bipolar transistors in the same circuit.

Both the SN65LBC180 and SN75LBC180 combine a differential line driver and receiver with 3-state outputs and operate from a single 5-V supply. The driver and receiver have active-high and active-low enables, respectively, which can be externally connected to function as a direction control. The driver differential outputs and the receiver differential inputs are connected to separate terminals for full-duplex operation and are designed to present minimum loading to the bus whether disabled or powered off ($V_{CC} = 0$). These parts feature a wide common-mode voltage range making them suitable for point-to-point or multipoint data-bus applications.

**D OR N PACKAGE
(TOP VIEW)**

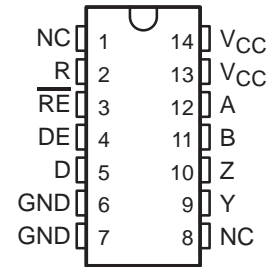

NC—No internal connection

Function Tables

DRIVER

INPUT D	ENABLE DE	OUTPUTS	
		Y	Z
H	H	H	L
L	H	L	H
X	L	Z	Z

RECEIVER

DIFFERENTIAL INPUTS A-B	ENABLE RE	OUTPUT R
$V_{ID} \geq 0.2$ V	L	H
-0.2 V $< V_{ID} < 0.2$ V	L	?
$V_{ID} \leq -0.2$ V	L	L
X	H	Z
Open circuit	L	H

H = high level, L = low level, ? = indeterminate, X = irrelevant, Z = high impedance (off)

logic symbol†

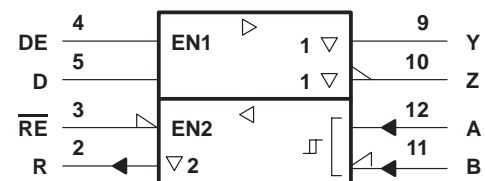

† This symbol is in accordance with ANSI/IEEE Std 91-1984 and IEC Publication 617-12.

logic diagram (positive logic)

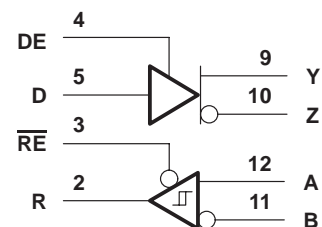

LinBiCMOS is a trademark of Texas Instruments Incorporated.

PRODUCTION DATA information is current as of publication date. Products conform to specifications per the terms of Texas Instruments standard warranty. Production processing does not necessarily include testing of all parameters.



POST OFFICE BOX 655303 • DALLAS, TEXAS 75265

Copyright © 1995, Texas Instruments Incorporated

SN65LBC180, SN75LBC180 LOW-POWER DIFFERENTIAL LINE DRIVER AND RECEIVER PAIRS

SLLS174A – FEBRUARY 1994 – REVISED MAY 1995

description (continued)

The devices also provide positive and negative output-current limiting and thermal shutdown for protection from line fault conditions. The line driver shuts down at a junction temperature of approximately 172°C.

The SN65LBC180 and SN75LBC180 are available in the 14-pin dual-in-line and small-outline packages. The SN75LBC180 is characterized for operation over the commercial temperature range of 0°C to 70°C. The SN65LBC180 is characterized over the industrial temperature range of -40°C to 85°C.

schematics of inputs and outputs

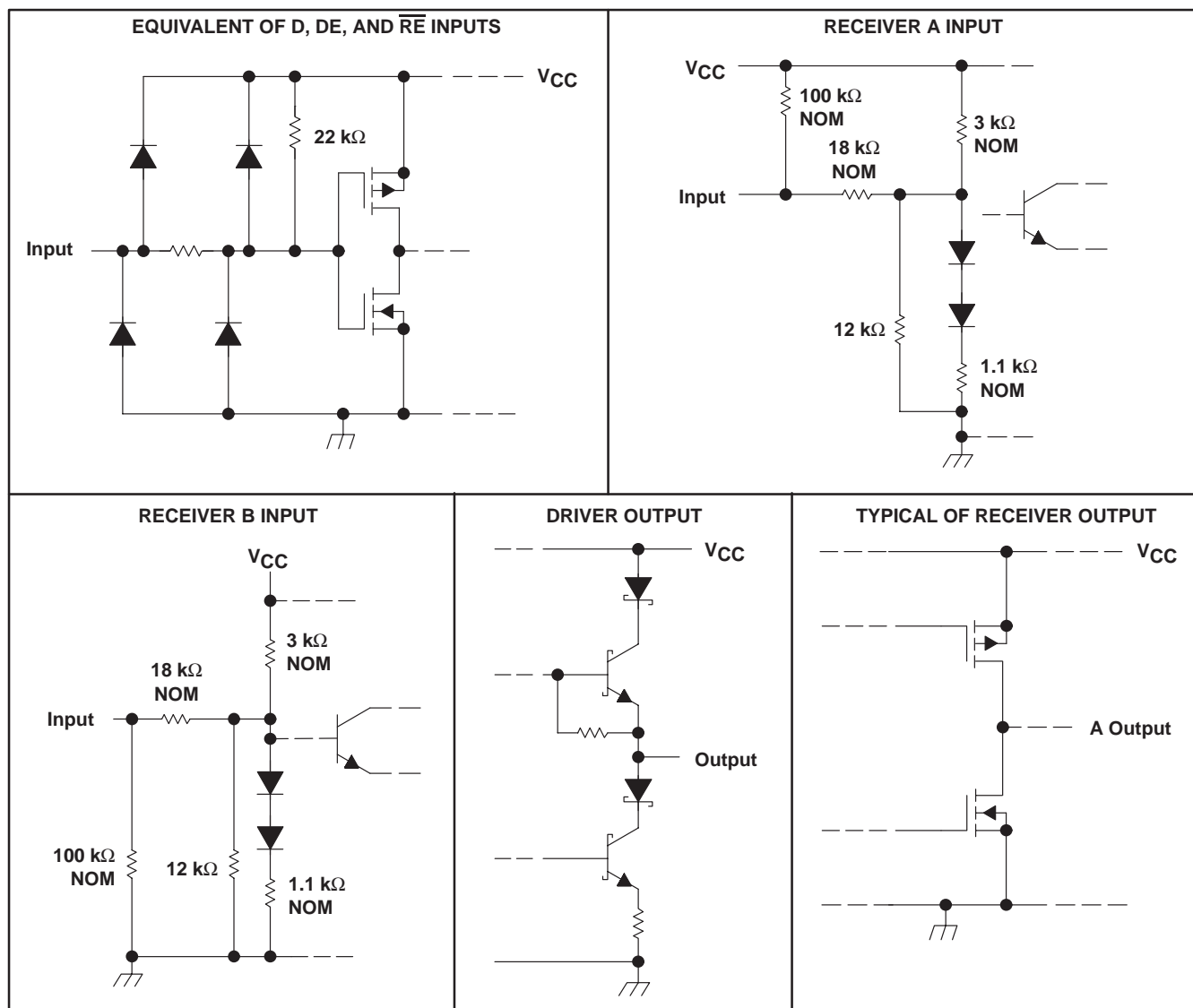

SN65LBC180, SN75LBC180 LOW-POWER DIFFERENTIAL LINE DRIVER AND RECEIVER PAIRS

SLLS174A – FEBRUARY 1994 – REVISED MAY 1995

absolute maximum ratings over operating free-air temperature range (unless otherwise noted)†

Supply voltage range, V_{CC} (see Note 1)	–0.3 V to 7 V
Input voltage range, V_I (A, B)(see Note 1)	–10 V to 15 V
Input voltage range, V_I (DE, \overline{RE} , D, or R)(see Note 1)	–0.3 V to 7 V
Continuous total power dissipation (see Note 2)	internally limited
Total power dissipation	See Dissipation Rating Table
Operating free-air temperature range, T_A : SN65LBC180	–40°C to 85°C
SN75LBC180	0°C to 70°C
Storage temperature range, T_{stg}	–65°C to 150°C
Lead temperature 1,6 mm (1/16 inch) from case for 10 seconds	260°C

† Stresses beyond those listed under “absolute maximum ratings” may cause permanent damage to the device. These are stress ratings only, and functional operation of the device at these or any other conditions beyond those indicated under “recommended operating conditions” is not implied. Exposure to absolute-maximum-rated conditions for extended periods may affect device reliability.

- NOTES: 1. All voltage values are with respect to GND.
2. The maximum operating junction temperature is internally limited. Use the dissipation rating table to operate below this temperature.

DISSIPATION RATING TABLE

PACKAGE	$T_A \leq 25^\circ\text{C}$	DERATING FACTOR	$T_A = 70^\circ\text{C}$	$T_A = 85^\circ\text{C}$
	POWER RATING	ABOVE $T_A = 25^\circ\text{C}$	POWER RATING	POWER RATING
D	950 mW	7.6 mW/°C	608 mW	494 mW
N	1150 mW	9.2 mW/°C	736 mW	598 mW

recommended operating conditions

		MIN	NOM	MAX	UNIT
Supply voltage, V_{CC}		4.75	5	5.25	V
High-level input voltage, V_{IH}	D, DE, and \overline{RE}	2			V
Low-level input voltage, V_{IL}	D, DE, and \overline{RE}			0.8	V
Differential input voltage, V_{ID}		–6‡		6	V
Voltage at any bus terminal (separately or common mode), V_O , V_I , or V_{IC}	A, B, Y, or Z	–7‡		12	V
High-level output current, I_{OH}	Y or Z			–60	mA
	R			–8	
Low-level output current, I_{OL}	Y or Z			60	mA
	R			8	
Operating free-air temperature, T_A	SN65LBC180	–40		85	°C
	SN75LBC180	0		70	

‡ The algebraic convention where the least positive (more negative) limit is designated minimum, is used in this data sheet for the differential input voltage, voltage at any bus terminal, operating temperature, input threshold voltage, and common-mode output voltage.



SN65LBC180, SN75LBC180 LOW-POWER DIFFERENTIAL LINE DRIVER AND RECEIVER PAIRS

SLLS174A – FEBRUARY 1994 – REVISED MAY 1995

DRIVER SECTION

electrical characteristics over recommended operating conditions (unless otherwise noted)

PARAMETER		TEST CONDITIONS		MIN	TYP†	MAX	UNIT
V _{IK}	Input clamp voltage	I _I = -18 mA				-1.5	V
V _{OD}	Differential output voltage magnitude (see Note 3)	R _L = 54 Ω, See Figure 1	SN65LBC180	1.1	2.5	5	V
			SN75LBC180	1.5	2.5	5	
		R _L = 60 Ω, See Figure 2	SN65LBC180	1.1	2	5	
			SN75LBC180	1.5	2	5	
Δ V _{OD}	Change in magnitude of differential output voltage (see Note 4)	See Figures 1 and 2				±0.2	V
V _{OC}	Common-mode output voltage	R _L = 54 Ω, See Figure 1		1	2.5	3	V
Δ V _{OC}	Change in magnitude of common-mode output voltage (see Note 4)					±0.2	V
I _O	Output current with power off	V _{CC} = 0, V _O = -7 V to 12 V				±100	μA
I _{OZ}	High-impedance-state output current	V _O = -7 V to 12 V				±100	μA
I _{IH}	High-level input current	V _I = 2.4 V				-100	μA
I _{IL}	Low-level input current	V _I = 0.4 V				-100	μA
I _{OS}	Short-circuit output current	-7 V ≤ V _O ≤ 12 V				±250	mA
I _{CC}	Supply current	Receiver disabled	Outputs enabled			5	mA
			Outputs disabled			3	

† All typical values are at V_{CC} = 5 V and T_A = 25°C.

NOTES: 3. The minimum V_{OD} specification of the SN65LBC180 may not fully comply with ANSI RS-485 at operating temperatures below 0°C. System designers should take the possibly lower output signal into account in determining the maximum signal-transmission distance.

4. Δ|V_{OD}| and Δ|V_{OC}| are the changes in the steady-state magnitude of V_{OD} and V_{OC}, respectively, that occur when the input is changed from a high level to a low level.

switching characteristics, V_{CC} = 5 V, T_A = 25°C

PARAMETER		TEST CONDITIONS		MIN	TYP	MAX	UNIT
t _{d(OD)}	Differential output delay time	R _L = 54 Ω, See Figure 3		7	12	18	ns
t _{t(OD)}	Differential output transition time			5	10	20	ns
t _{pZH}	Output enable time to high level	R _L = 110 Ω, See Figure 4				35	ns
t _{pZL}	Output enable time to low level	R _L = 110 Ω, See Figure 5				35	ns
t _{pHZ}	Output disable time from high level	R _L = 110 Ω, See Figure 4				50	ns
t _{pLZ}	Output disable time from low level	R _L = 110 Ω, See Figure 5				35	ns



SN65LBC180, SN75LBC180

LOW-POWER DIFFERENTIAL LINE DRIVER AND RECEIVER PAIRS

SLLS174A – FEBRUARY 1994 – REVISED MAY 1995

RECEIVER SECTION

electrical characteristics over recommended operating conditions (unless otherwise noted)

PARAMETER		TEST CONDITIONS	MIN	TYP	MAX	UNIT
V_{IT+}	Positive-going input threshold voltage	$I_O = -8 \text{ mA}$			0.2	V
V_{IT-}	Negative-going input threshold voltage	$I_O = 8 \text{ mA}$	-0.2			V
V_{hys}	Hysteresis voltage ($V_{IT+} - V_{IT-}$)			45		mV
V_{IK}	Enable-input clamp voltage	$I_I = -18 \text{ mA}$			-1.5	V
V_{OH}	High-level output voltage	$V_{ID} = 200 \text{ mV}$, $I_{OH} = -8 \text{ mA}$	3.5	4.5		V
V_{OL}	Low-level output voltage	$V_{ID} = -200 \text{ mV}$, $I_{OL} = 8 \text{ mA}$		0.3	0.5	V
I_{OZ}	High-impedance-state output current	$V_O = 0 \text{ V to } V_{CC}$			± 20	μA
I_{IH}	High-level enable-input current	$V_{IH} = 2.4 \text{ V}$			-50	μA
I_{IL}	Low-level enable-input current	$V_{IL} = 0.4 \text{ V}$			-100	μA
I_I	Bus input current	$V_I = 12 \text{ V}$, $V_{CC} = 5 \text{ V}$, Other input at 0 V		0.7	1	mA
		$V_I = 12 \text{ V}$, $V_{CC} = 0 \text{ V}$, Other input at 0 V		0.8	1	
		$V_I = -7 \text{ V}$, $V_{CC} = 5 \text{ V}$, Other input at 0 V		-0.5	-0.8	
		$V_I = -7 \text{ V}$, $V_{CC} = 0 \text{ V}$, Other input at 0 V		-0.5	-0.8	
I_{CC}	Supply current	Driver disabled	Outputs enabled		5	mA
			Outputs disabled		3	

switching characteristics, $V_{CC} = 5 \text{ V}$, $T_A = 25^\circ\text{C}$

PARAMETER		TEST CONDITIONS	MIN	TYP	MAX	UNIT
t_{PHL}	Propagation delay time, high- to low-level output	$V_{ID} = -1.5 \text{ V to } 1.5 \text{ V}$, See Figure 6	11	22	33	ns
t_{PLH}	Propagation delay time, low- to high-level output		11	22	33	ns
$t_{sk(p)}$	Pulse skew ($ t_{PHL} - t_{PLH} $)			3	6	ns
t_t	Transition time			5	8	ns
t_{PZH}	Output enable time to high level	See Figure 7			35	ns
t_{PZL}	Output enable time to low level				30	ns
t_{PHZ}	Output disable time from high level				35	ns
t_{PLZ}	Output disable time from low level				30	ns

SN65LBC180, SN75LBC180 LOW-POWER DIFFERENTIAL LINE DRIVER AND RECEIVER PAIRS

SLLS174A – FEBRUARY 1994 – REVISED MAY 1995

PARAMETER MEASUREMENT INFORMATION

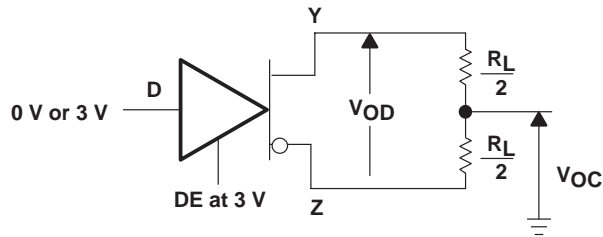

Figure 1. Differential and Common-Mode Output Voltages

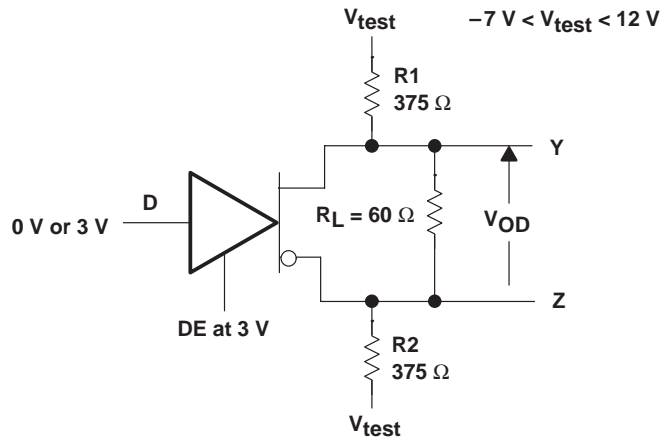
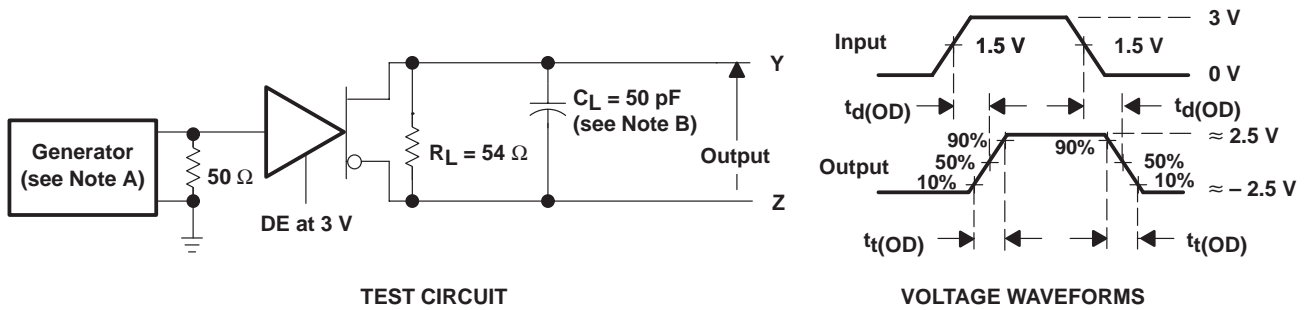

Figure 2. Driver V_{OD} Test Circuit



- NOTES: A. The input pulse is supplied by a generator having the following characteristics: PRR > 1 MHz, 50% duty cycle, $t_r \leq 6$ ns, $t_f \leq 6$ ns, $Z_O = 50 \Omega$.
B. C_L includes probe and jig capacitance.

Figure 3. Driver Test Circuit and Differential Output Delay and Transition Time Voltage Waveforms

PARAMETER MEASUREMENT INFORMATION

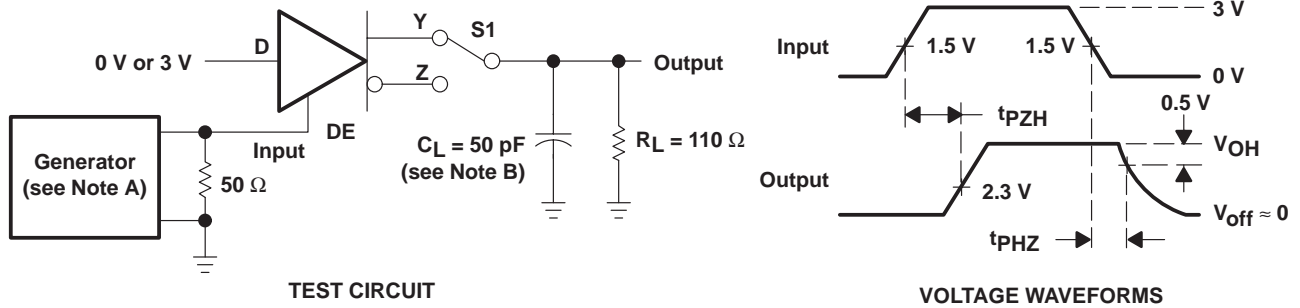

Figure 4. Driver Test Circuit and Enable and Disable Time Waveforms

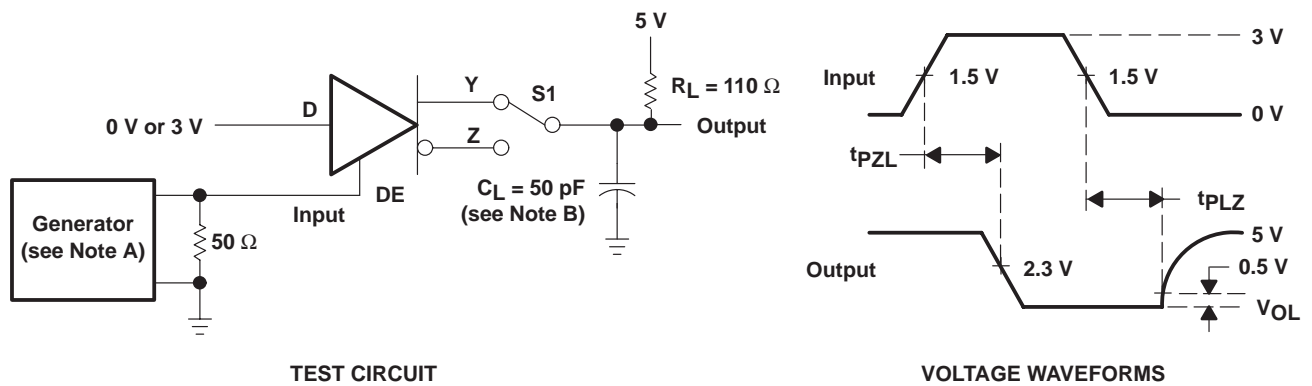
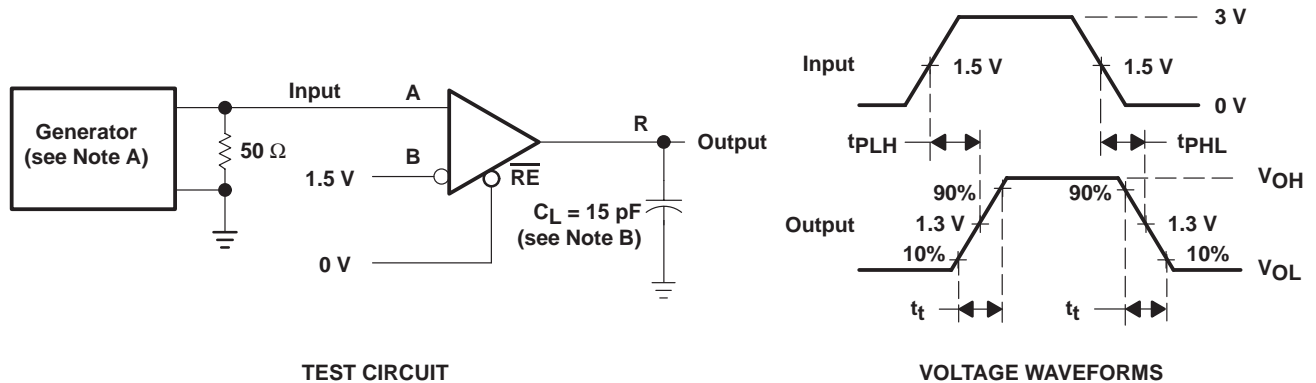

Figure 5. Driver Test Circuit and Enable and Disable Time Voltage Waveforms



- NOTES: A. The input pulse is supplied by a generator having the following characteristics: $PRR \leq 1 \text{ MHz}$, 50% duty cycle, $t_r \leq 6 \text{ ns}$, $t_f \leq 6 \text{ ns}$, $Z_O = 50 \Omega$.
B. C_L includes probe and jig capacitance.

Figure 6. Receiver Test Circuit and Propagation Delay Time Voltage Waveforms

SN65LBC180, SN75LBC180 LOW-POWER DIFFERENTIAL LINE DRIVER AND RECEIVER PAIRS

SLLS174A – FEBRUARY 1994 – REVISED MAY 1995

PARAMETER MEASUREMENT INFORMATION

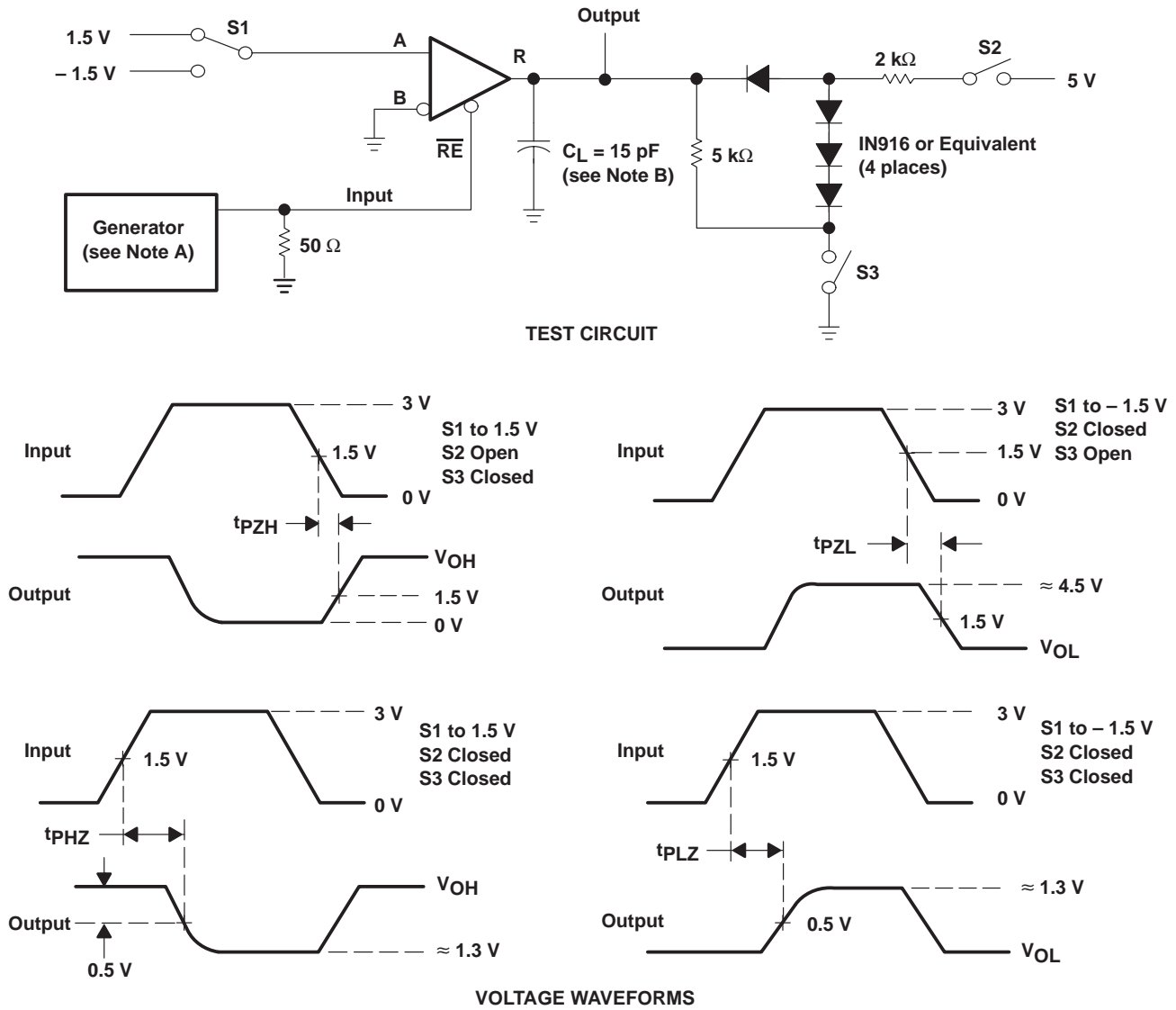

- NOTES: A. The input pulse is supplied by a generator having the following characteristics: PRR \leq 1 MHz, 50% duty cycle, $t_r \leq$ 6 ns, $t_f \leq$ 6 ns, $Z_O = 50 \Omega$.
 B. C_L includes probe and jig capacitance.

Figure 7. Receiver Output Enable and Disable Times

TYPICAL CHARACTERISTICS

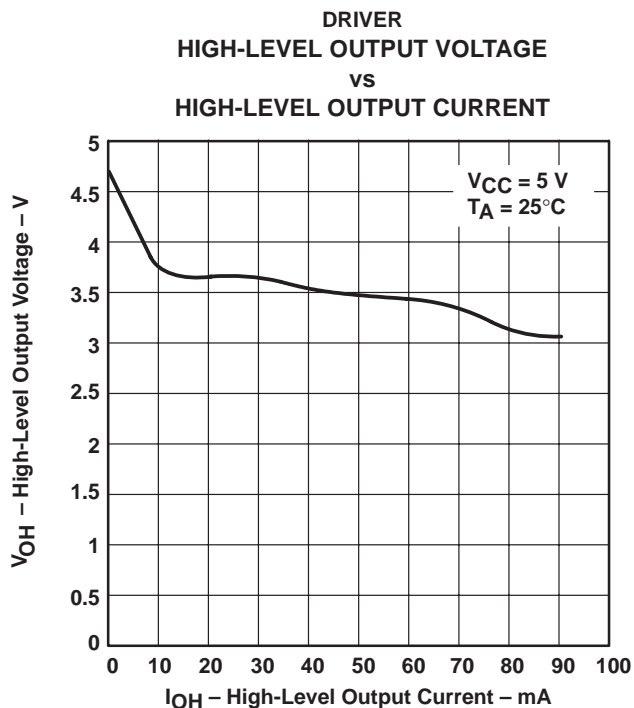

Figure 8

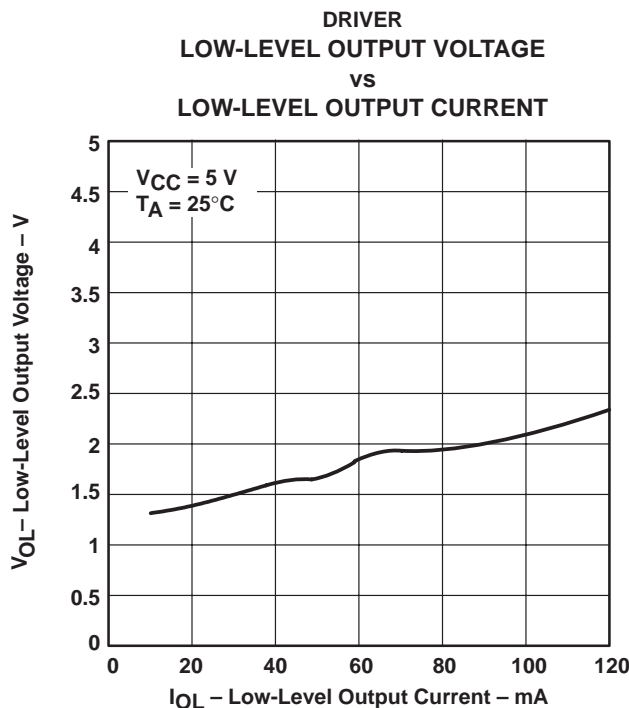

Figure 9

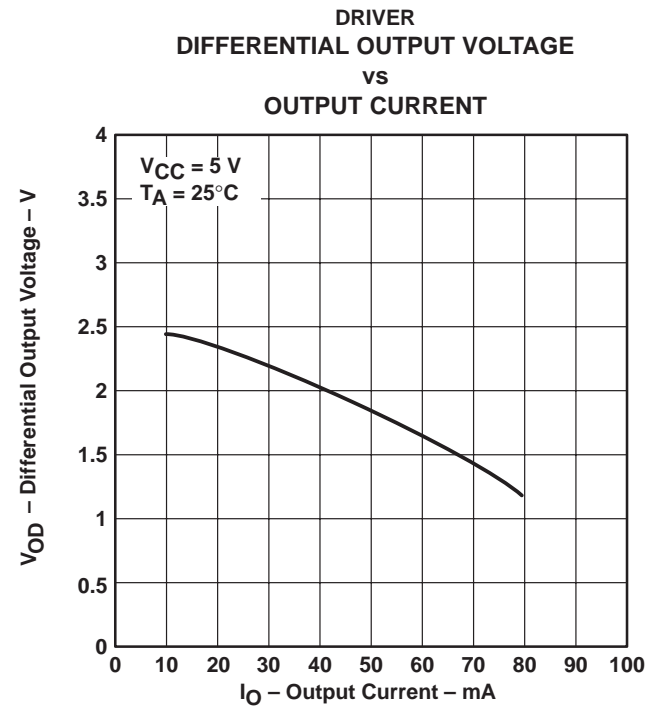

Figure 10

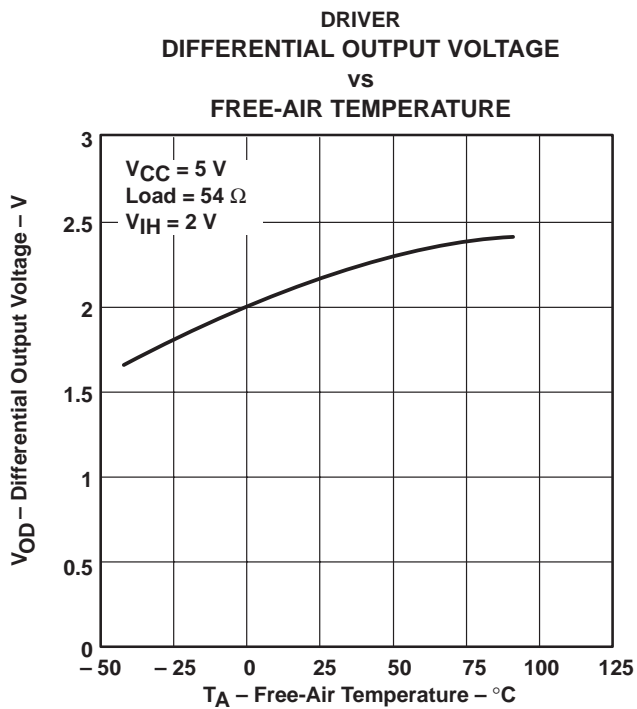

Figure 11

SN65LBC180, SN75LBC180 LOW-POWER DIFFERENTIAL LINE DRIVER AND RECEIVER PAIRS

SLLS174A – FEBRUARY 1994 – REVISED MAY 1995

TYPICAL CHARACTERISTICS

DRIVER
DIFFERENTIAL DELAY TIMES
VS
FREE-AIR TEMPERATURE

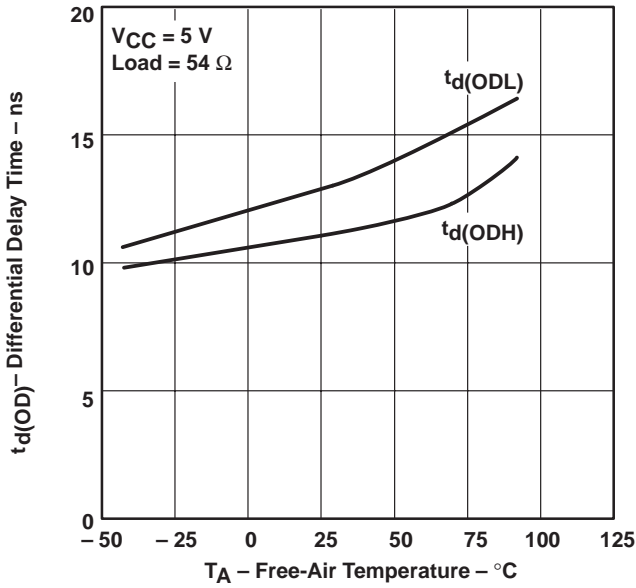

Figure 12

DRIVER
OUTPUT CURRENT
VS
SUPPLY VOLTAGE

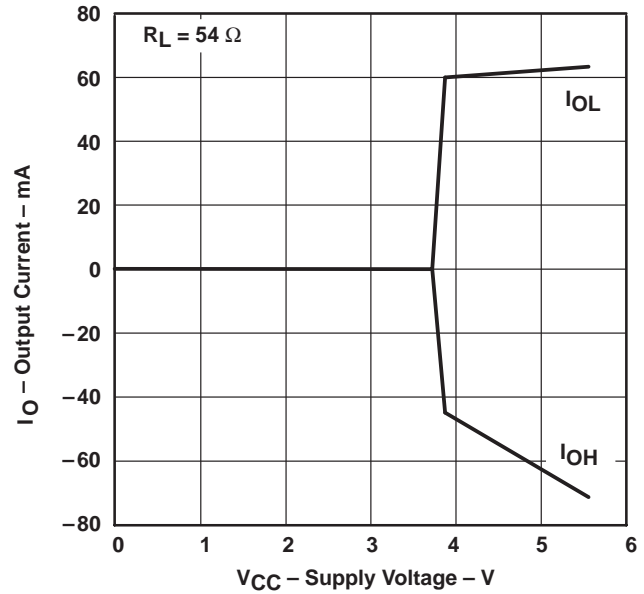

Figure 13

RECEIVER
HIGH-LEVEL OUTPUT VOLTAGE
VS
HIGH-LEVEL OUTPUT CURRENT

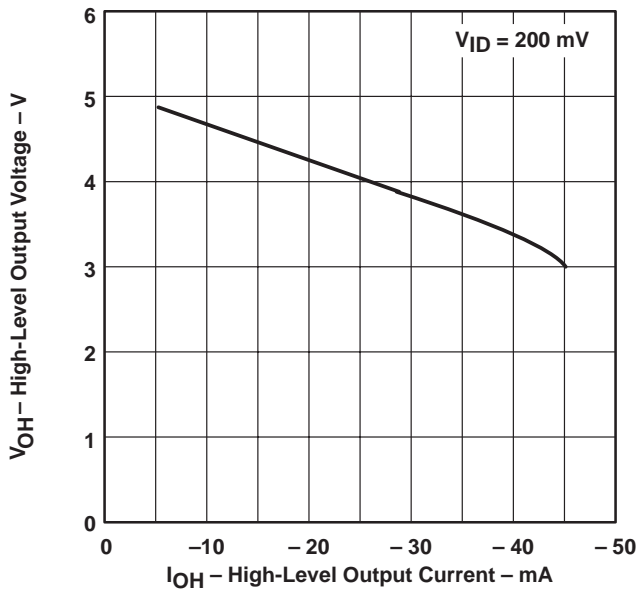

Figure 14

RECEIVER
LOW-LEVEL OUTPUT VOLTAGE
VS
LOW-LEVEL OUTPUT CURRENT

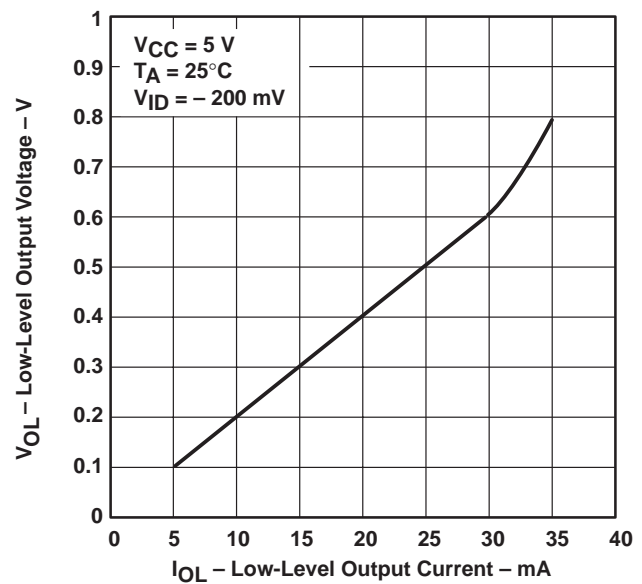

Figure 15

TYPICAL CHARACTERISTICS

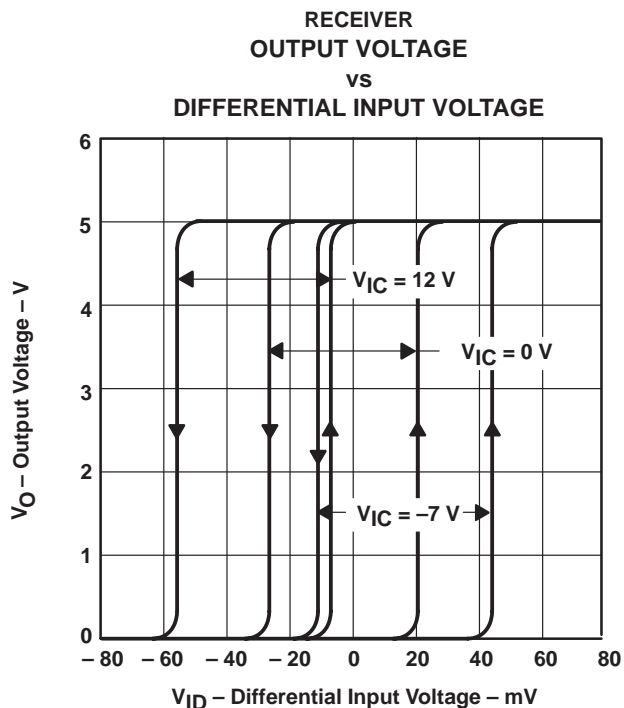

Figure 16

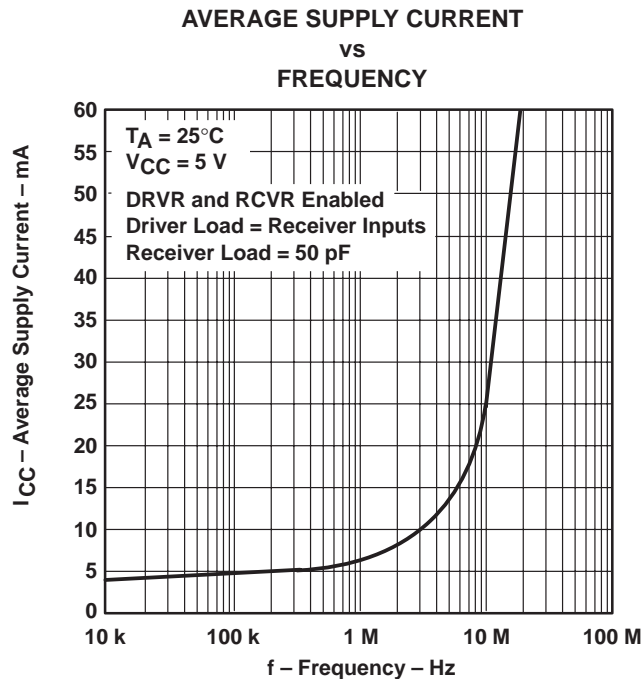

Figure 17

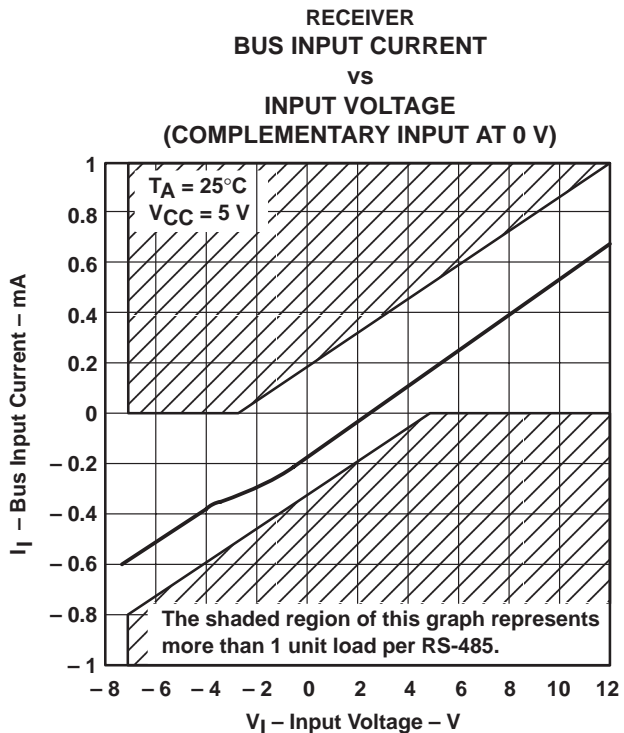

Figure 18

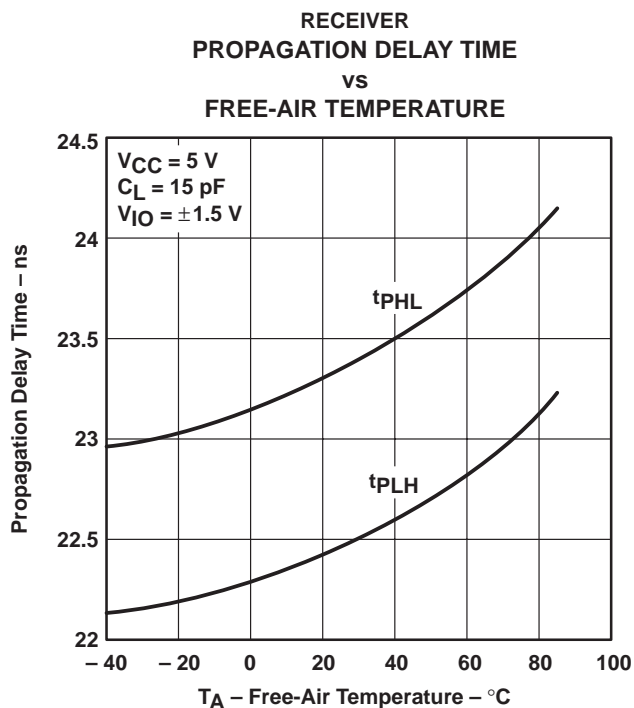
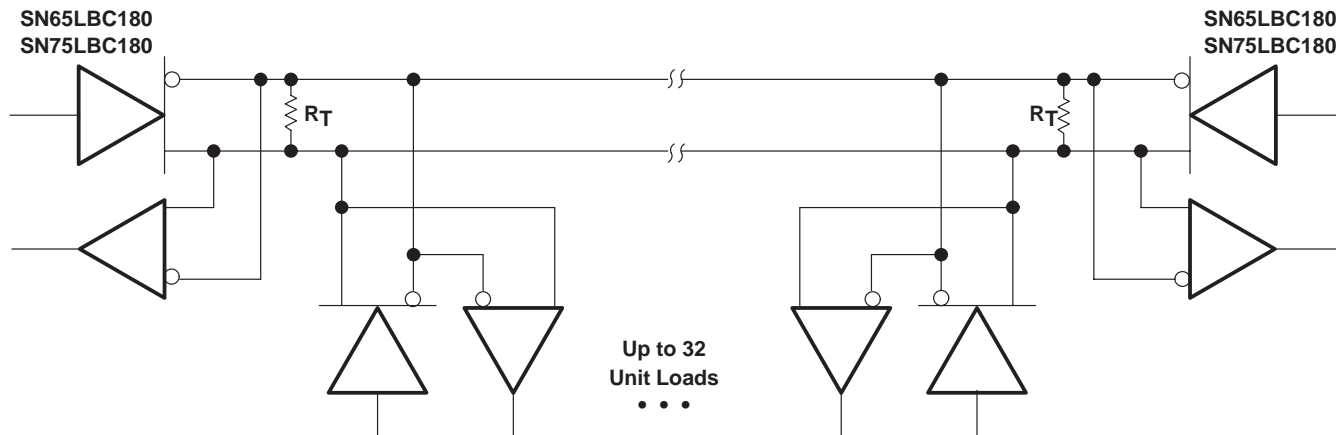

Figure 19

SN65LBC180, SN75LBC180 LOW-POWER DIFFERENTIAL LINE DRIVER AND RECEIVER PAIRS

SLLS174A – FEBRUARY 1994 – REVISED MAY 1995

APPLICATION INFORMATION



NOTE A: The line should be terminated at both ends in its characteristic impedance ($R_T = Z_0$). Stub lengths off the main line should be kept as short as possible. One SN75LBC180 typically represents less than one unit load.

Figure 20. Typical Application Circuit

SN65LBC180, SN75LBC180 LOW-POWER DIFFERENTIAL LINE DRIVER AND RECEIVER PAIRS

SLLS174A – FEBRUARY 1994 – REVISED MAY 1995

MECHANICAL DATA

D (R-PDSO-G)**

PLASTIC SMALL-OUTLINE PACKAGE

14 PIN SHOWN

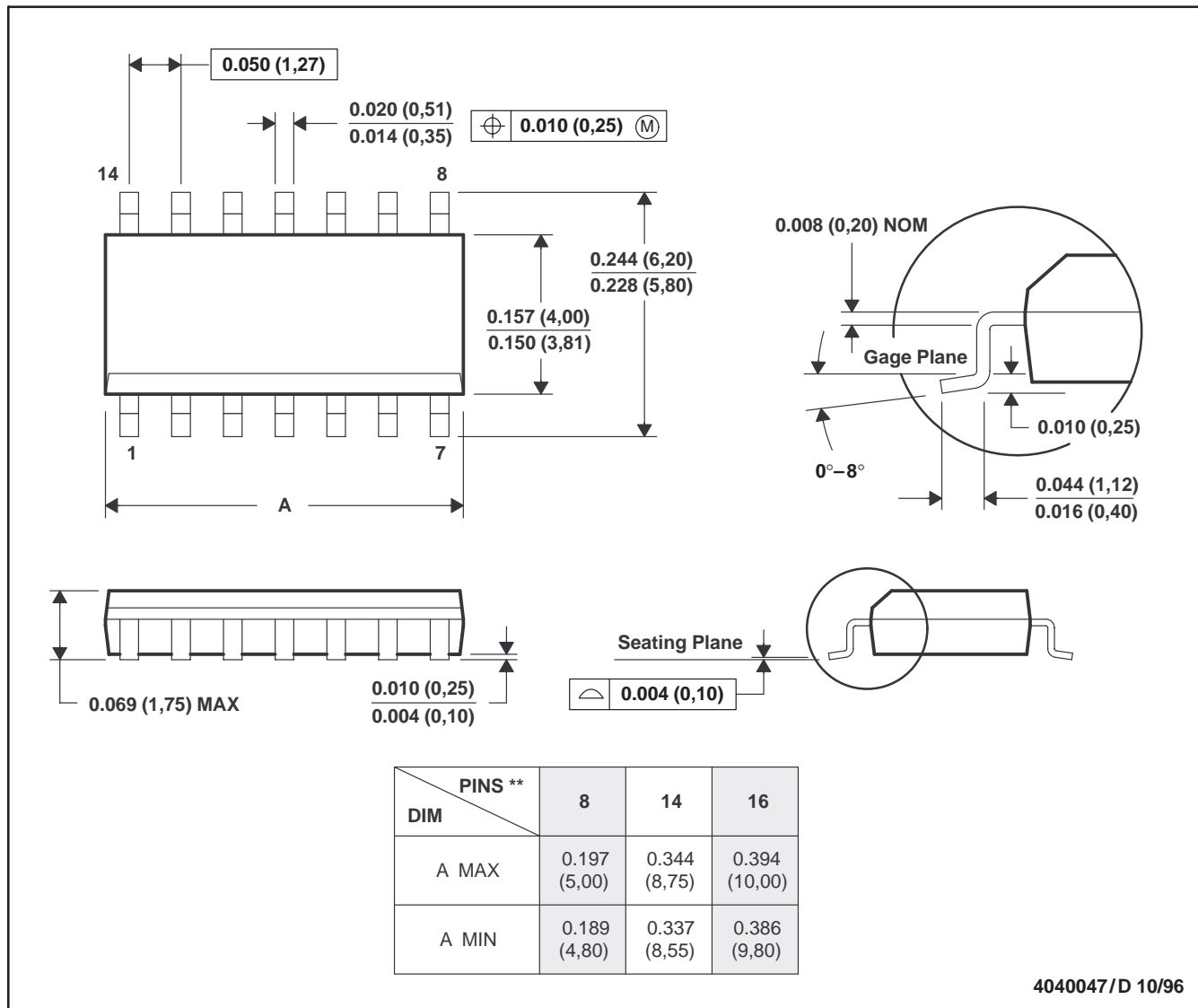

- NOTES: B. All linear dimensions are in inches (millimeters).
 C. This drawing is subject to change without notice.
 D. Body dimensions do not include mold flash or protrusion, not to exceed 0.006 (0,15).
 E. Falls within JEDEC MS-012

SN65LBC180, SN75LBC180 LOW-POWER DIFFERENTIAL LINE DRIVER AND RECEIVER PAIRS

SLLS174A – FEBRUARY 1994 – REVISED MAY 1995

MECHANICAL DATA

N (R-PDIP-T**)

PLASTIC DUAL-IN-LINE PACKAGE

16 PIN SHOWN

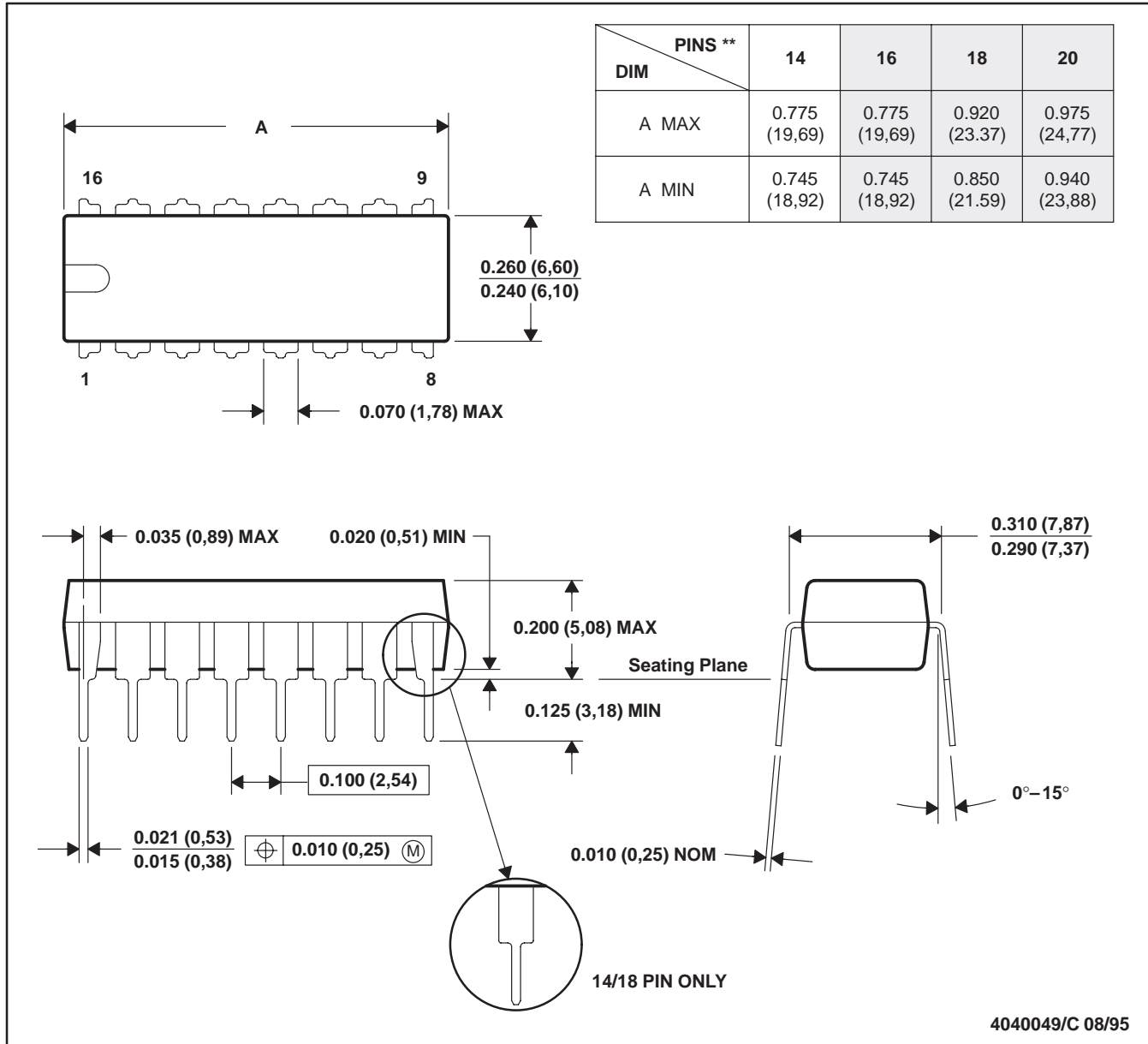

- NOTES: A. All linear dimensions are in inches (millimeters).
 B. This drawing is subject to change without notice.
 C. Falls within JEDEC MS-001 (20 pin package is shorter than MS-001.)

IMPORTANT NOTICE

Texas Instruments (TI) reserves the right to make changes to its products or to discontinue any semiconductor product or service without notice, and advises its customers to obtain the latest version of relevant information to verify, before placing orders, that the information being relied on is current and complete.

TI warrants performance of its semiconductor products and related software to the specifications applicable at the time of sale in accordance with TI's standard warranty. Testing and other quality control techniques are utilized to the extent TI deems necessary to support this warranty. Specific testing of all parameters of each device is not necessarily performed, except those mandated by government requirements.

Certain applications using semiconductor products may involve potential risks of death, personal injury, or severe property or environmental damage ("Critical Applications").

TI SEMICONDUCTOR PRODUCTS ARE NOT DESIGNED, INTENDED, AUTHORIZED, OR WARRANTED TO BE SUITABLE FOR USE IN LIFE-SUPPORT APPLICATIONS, DEVICES OR SYSTEMS OR OTHER CRITICAL APPLICATIONS.

Inclusion of TI products in such applications is understood to be fully at the risk of the customer. Use of TI products in such applications requires the written approval of an appropriate TI officer. Questions concerning potential risk applications should be directed to TI through a local SC sales office.

In order to minimize risks associated with the customer's applications, adequate design and operating safeguards should be provided by the customer to minimize inherent or procedural hazards.

TI assumes no liability for applications assistance, customer product design, software performance, or infringement of patents or services described herein. Nor does TI warrant or represent that any license, either express or implied, is granted under any patent right, copyright, mask work right, or other intellectual property right of TI covering or relating to any combination, machine, or process in which such semiconductor products or services might be or are used.